



HY2131

Specification

Protection IC for 2/3-Cell Lithium Ion/Lithium Polymer
Batteries in Series
(For Secondary Protection)

Table of Contents

1. GENERAL DESCRIPTION	4
2. FEATURES	4
3. APPLICATIONS.....	4
4. BLOCK DIAGRAM.....	5
5. ORDERING INFORMATION.....	5
6. MODEL LIST.....	6
7. PIN CONFIGURATION AND PACKAGE MARKING INFORMATION	6
8. TEST CIRCUIT	7
9. ABSOLUTE MAXIMUM RATED VALUE	8
10. ELECTRICAL CHARACTERISTICS	9
10.1. Electrical Parameters	9
11. EXAMPLE OF APPLICATION CIRCUIT FOR BATTERY PROTECTION IC.....	19
11.1. 3-Cell in Series Connection	19
11.2. 2-Cell in Series Connection	19
12. DESCRIPTION OF OPERATION	22
12.1. Overcharge Status	22
12.2. Standby Status.....	23
12.3. Test Time Shortening Capability.....	23
13. TIMING DIAGRAM.....	24
14. PACKAGE INFORMATION	25
14.1. TSOT-23-6 Package	25
15. TAPE & REEL INFORMATION.....	26
15.1. Tape & Reel Information---TSOT-23-6.....	26
16. REVISION RECORD.....	27

Attention :

1. HYCON Technology Corp. reserves the right to change the content of this datasheet without further notice. For most up-to-date information, please constantly visit our website:
<http://www.hycontek.com> .
2. HYCON Technology Corp. is not responsible for problems caused by figures or application circuits narrated herein whose related industrial properties belong to third parties.
3. Specifications of any HYCON Technology Corp. products detailed or contained herein stipulate the performance, characteristics, and functions of the specified products in the independent state. We does not guarantee of the performance, characteristics, and functions of the specified products as placed in the customer's products or equipment. Constant and sufficient verification and evaluation is highly advised.
4. Please note the operating conditions of input voltage, output voltage and load current and ensure the IC internal power consumption does not exceed that of package tolerance. HYCON Technology Corp. assumes no responsibility for equipment failures that resulted from using products at values that exceed, even momentarily, rated values listed in products specifications of HYCON products specified herein.
5. Notwithstanding this product has built-in ESD protection circuit, please do not exert excessive static electricity to protection circuit.
6. Products specified or contained herein cannot be employed in applications which require extremely high levels of reliability, such as device or equipment affecting the human body, health/medical equipments, security systems, or any apparatus installed in aircrafts and other vehicles.
7. Despite the fact that HYCON Technology Corp. endeavors to enhance product quality as well as reliability in every possible way, failure or malfunction of semiconductor products may happen. Hence, users are strongly recommended to comply with safety design including redundancy and fire-precaution equipments to prevent any accidents and fires that may follow.
8. Use of the information described herein for other purposes and/or reproduction or copying without the permission of HYCON Technology Corp. is strictly prohibited.

1. General Description

The series of HY2131 ICs is a secondary protection IC for lithium ion/lithium polymer rechargeable batteries and it also comprises high-accuracy voltage detectors and delay circuits.

These ICs are applicable to protect overcharge of 2/3-cell lithium ion/lithium polymer rechargeable batteries.

2. Features

The features that whole series of HY2131 comprised are as follows:

(1) High-accuracy voltage detection circuit

- Overcharge detection voltage V_{CU_n} ($n = 1, 2, 3$) 4.000V to 4.550V Accuracy: $\pm 20\text{mV}$
- Overcharge release voltage V_{CR_n} ($n = 1, 2, 3$) 3.800V to 4.500V Accuracy: $\pm 50\text{mV}$
- Standby detection voltage V_{SB_n} ($n = 1, 2, 3$) 3.500V Accuracy: $\pm 0.4\text{V}$

(2) Delay time is set by internal circuit (external capacitor is not needed)

6.0s Accuracy: $\pm 20\%$

(3) Delay time shortening function: overcharge detection delay time can be shortened by specific setup.

12ms Accuracy: $\pm 50\%$

For EX, as $V_{C2} = V_{C3} = V_{SS}$, the overcharge detection delay time of cell1 is shortened;

as $V_{C1} = V_{C2}$, $V_{C3} = V_{SS}$, the overcharge detection delay time of cell2 is shortened;

as $V_{C1} = V_{C2} = V_{C3}$, the overcharge detection delay time of cell3 is shortened.

(4) Output logic: Active high CMOS output; the high level is 4.7V (typical) output from regulator.

(5) Low current

- Operation mode 3.0 μA typ., 6.0 μA max. ($V_{CellIn} = 3.9\text{V}$)
- Standby mode 0.5 μA max. ($V_{CellIn} = 3.1\text{V}$)

(6) Selection of 2-cell/3-cell application: either 2-cell or 3-cell is selectable by means of external circuit.

(7) High voltage resistant design: the absolute maximum rated value is 30V.

(8) Wide operating temperature range: $-40\text{ }^{\circ}\text{C} \sim +85\text{ }^{\circ}\text{C}$

(9) Small package: TSOT-23-6

(10) Halogen free green product

3. Applications

- 2/3-cell lithium ion rechargeable battery pack (for secondary protection)
- 2/3-cell lithium polymer rechargeable battery pack (for secondary protection)

4. Block Diagram

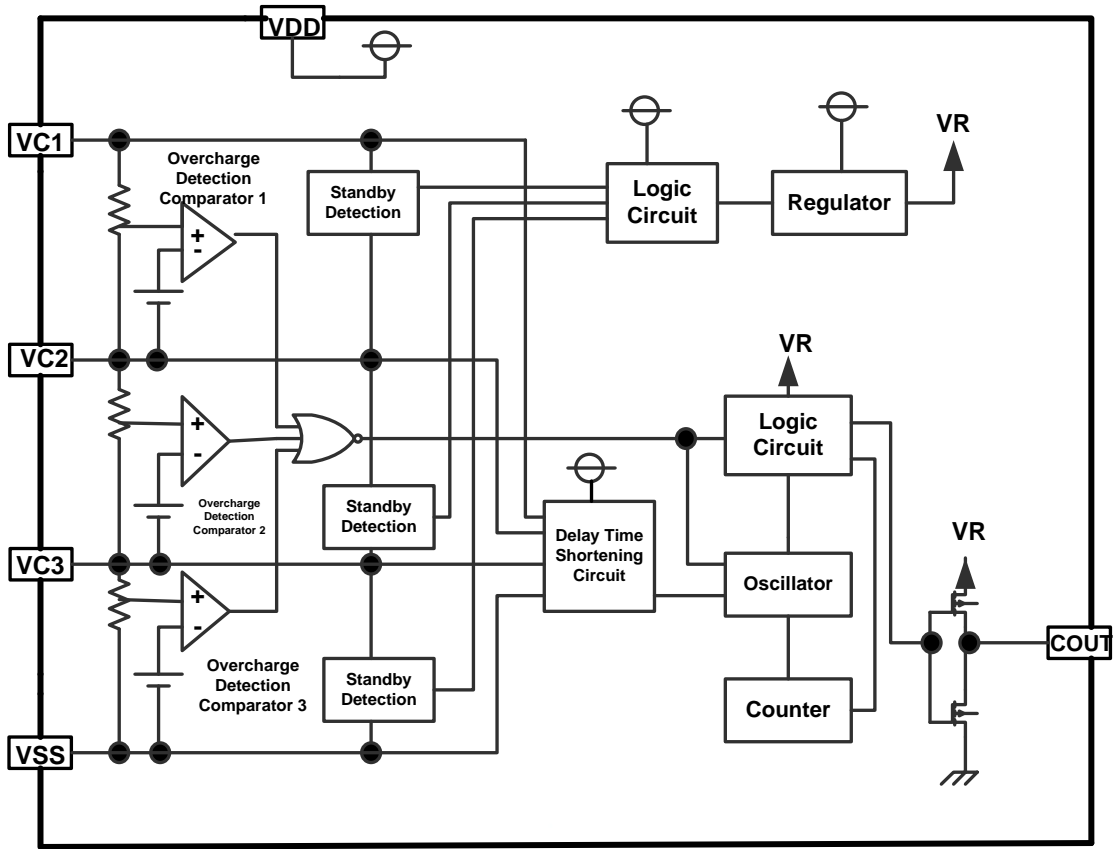

5. Ordering Information

- Definition of Product Name

HY2131—#%\$&

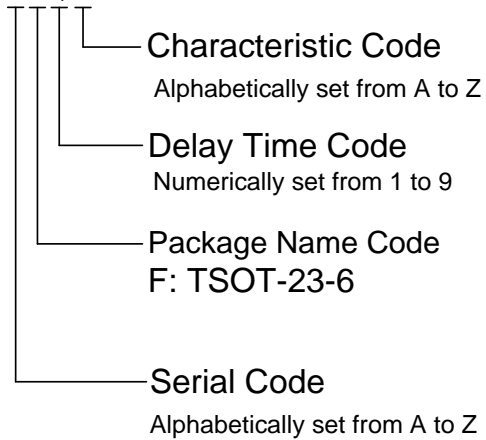

6. Model List

Table 1 Model list

Model \ Parameter	Overcharge Detection Voltage	Overcharge Release Voltage	Overcharge Delay Time	Overcharge Release Delay Time	Reset Delay Time of Overcharge Detection Counter
	V_{CU_n}	V_{CR_n}	T_{OC_n}	T_{CR_n}	T_{DTR}
HY2131-AF1A	4.350V	4.050V	6.0s	16ms	6ms
HY2131-BF1A	4.450V	4.150V	6.0s	16ms	6ms
HY2131-CF1A	4.400V	4.100V	6.0s	16ms	6ms
HY2131-DF1A	4.500V	4.200V	6.0s	16ms	6ms
HY2131-EF1A	4.550V	4.250V	6.0s	16ms	6ms

Remark:

Please contact our sales office for the products with detection voltage value other than those specified above.

7. Pin Configuration and Package Marking Information

- TSOT-23-6 package

Table 2 TSOT-23-6 package

Pin	Symbol	Description
1	VDD	Power end, positive power input pin
2	V_{C1}	Connection pin for positive voltage of battery 1
3	V_{C2}	connection pin for negative voltage of battery 1, positive voltage of battery 2
4	V_{C3}	Connection pin for negative voltage of battery 2, positive voltage of battery 3
5	VSS	Ground end, connection pin for negative voltage of battery 3
6	COUT	FET gate connection pin for charging control

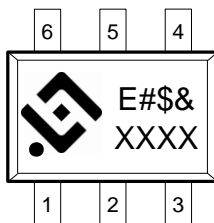

E: Product Name.

#: Serial code. Alphabetically set from A to Z.

\$: Delay time code. Numerically set from 1 to 9.

&: Feature code. Alphabetically set from A to Z.

XXXX: Traceability code.

8. Test Circuit

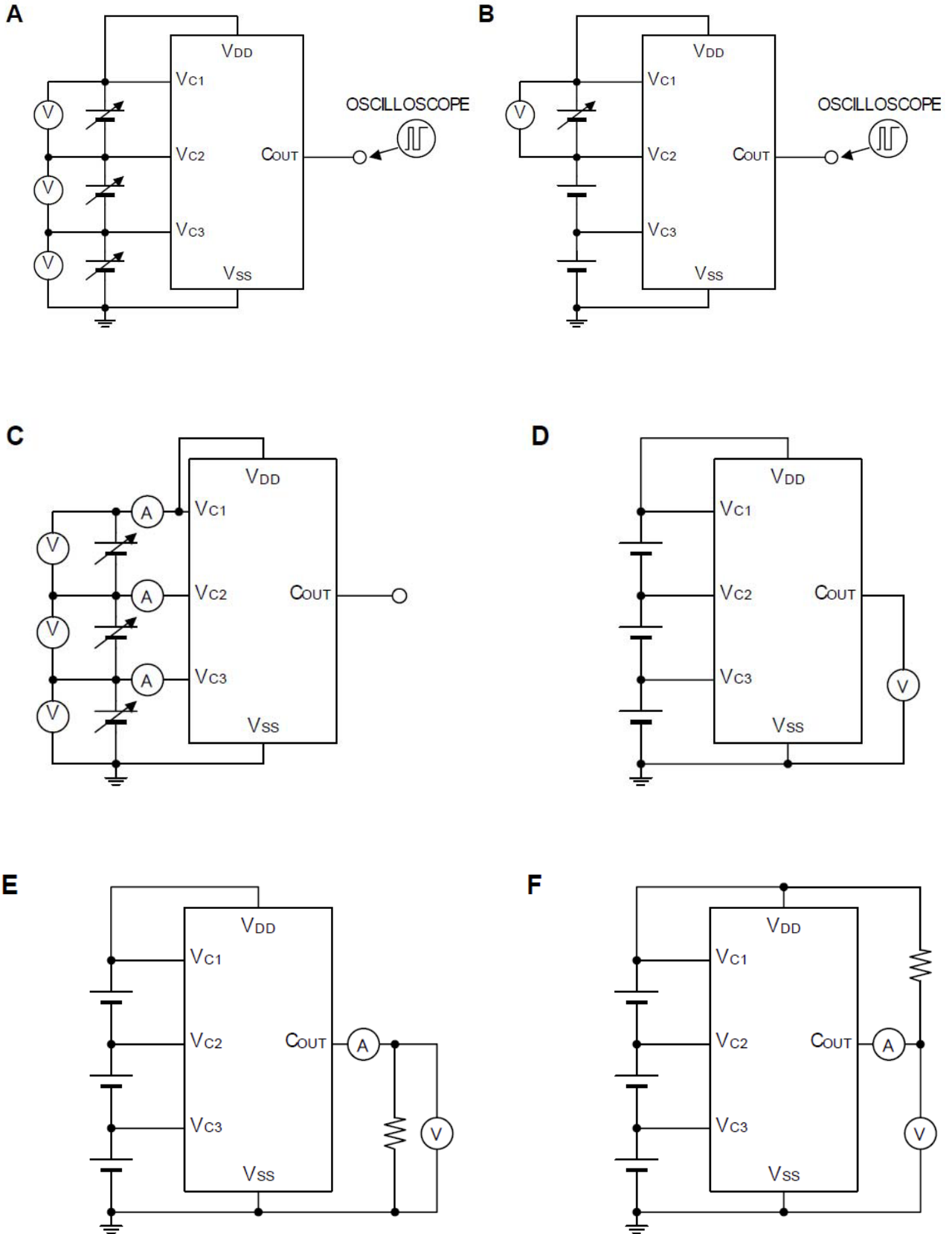

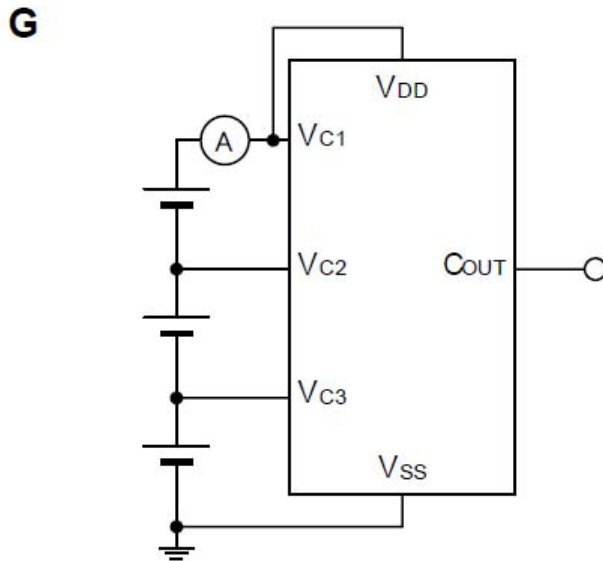

9. Absolute Maximum Rated Value

Table3 Absolute Maximum Rated Value (VSS = 0V, Ta=25 °C, unless indicated otherwise)

Item	Symbol	Specification	Unit
Input Voltage between VDD and VSS	V _{DD}	VSS-0.3 to VSS+30	V
V _{C1} Input pin Voltage	V _{C1}	V _{C2} -0.3 to V _{C2} +6.5	V
V _{C2} Input pin Voltage	V _{C2}	V _{C3} -0.3 to V _{C3} +6.5	V
V _{C3} Input pin Voltage	V _{C3}	-0.3 to 6.5	V
COUT Output pin Voltage	V _{COUT}	-0.3 to V _{OH1} +0.3	V
Operating Temperature Range	T _{OP}	-40 to +85	°C
Storage Temperature Range	T _{ST}	-40 to +125	°C
Tolerant Power Consumption	P _D	250	mW

10. Electrical Characteristics

10.1. Electrical Parameters

Table 4 HY2131-AF1A Electrical Parameters (VSS = 0V, Ta = 25 °C, unless indicated otherwise)

Item	Symbol	Condition	Min.	Typ.	Max.	Unit
Input Voltage						
VDD-VSS Operating Voltage	V _{DSOP1}	-	3.6	-	30	V
Current Consumption						
Operating Current	I _{DD}	V _{C1} =V _{C2} =V _{C3} =3.9V	-	3.0	6.0	μA
Standby Current	I _{PD}	V _{C1} =V _{C2} =V _{C3} =3.1V	-	0.3	0.5	μA
Detection Voltage						
Overcharge Detection Voltage n (*1)	V _{CU_n}		4.330	4.350	4.370	V
		-5 °C ~ 55 °C (*2)	4.325	4.350	4.375	V
Overcharge Release Voltage n (*1)	V _{CR_n}		4.000	4.050	4.100	V
Standby Detection Voltage	V _{SB}		3.1	3.5	3.9	V
Delay Time						
Overcharge Detection Delay Time	T _{OC_n}	V _{Cell_n} =3.9V, V _{Cell1} =3.9V→4.7V (*3)	4.8	6.0	7.2	s
Overcharge Release Delay Time	T _{CR_n}	V _{Cell_n} =3.9V, V _{Cell1} =4.7V → 3.9V (*3)	12.8	16	19.2	ms
Reset Delay Time of Overcharge Detection Counter	T _{DTR}	V _{Cell_n} =V _{CU_n} +0.050V→V _{CR_n} -0.100V→V _{CU_n} +0.050V→V _{CR_n} -0.100V	2	6	10	ms
Control Pin Output Voltage						
High Voltage of COUT pin Output	V _{COH1}	I _{COH} =0μA, V _{Cell_n} =4.7V (n=1, 2, 3)	4.0	4.7	5.4	V
High Voltage of COUT pin Output	V _{COH2}	I _{COH} =50μA, V _{Cell_n} =4.7V (n=1, 2, 3)	V _{COH1} -0.5	V _{COH1} -0.1	-	V
Low Voltage of COUT pin Output	V _{CL}	I _{COH} =50μA, V _{Cell_n} =3.9V (n=1, 2, 3)	-	0.1	0.5	V

Description:

*1. n=1, 2, 3.

*2. The parameters within this temperature range are design guarantee values instead of screened values from high, low temperature measurement.

*3. V_{cell_n} is voltage of Cell-n, n=1, 2, 3.

Table 5 HY2131-AF1A Electrical Parameters (VSS = 0V, Ta = -40~85 °C (*2), unless indicated otherwise)

Item	Symbol	Condition	Min.	Typ.	Max.	Unit
Input Voltage						
VDD-VSS Operating Voltage	V_{DSOP1}	-	3.6	-	30	V
Current Consumption						
Operating Current	I_{DD}	$V_{C1}=V_{C2}=V_{C3}=3.9V$	-	3.0	6.6	μA
Standby Current	I_{PD}	$V_{C1}=V_{C2}=V_{C3}=3.1V$	-	0.3	0.8	μA
Detection Voltage						
Overcharge Detection Voltage n (*1)	V_{CUn}		4.311	4.350	4.384	V
Overcharge Release Voltage n (*1)	V_{CRn}		3.982	4.050	4.118	V
Standby Detection Voltage	V_{SB}		2.96	3.5	3.94	V
Delay Time						
Overcharge Detection Delay Time	T_{OCn}	$V_{Celln}=3.9V, V_{Cell1}=3.9V \rightarrow 4.7V$ (*3)	3.1	6.0	9.4	s
Overcharge Release Delay Time	T_{CRn}	$V_{Celln}=3.9V, V_{Cell1}=4.7V \rightarrow 3.9V$ (*3)	8.5	16	25.2	ms
Reset Delay Time of Overcharge Detection Counter	T_{DTR}	$V_{Celln}=V_{CUn}+0.050V \rightarrow V_{CRn}-0.100V \rightarrow V_{CUn}+0.050V \rightarrow V_{CRn}-0.100V$	0.04	6	11.5	ms
Control Pin Output Voltage						
High Voltage of COUT pin Output	V_{COH1}	$I_{COH}=0\mu A, V_{Celln}=4.7V$ (n=1, 2, 3)	3.6	4.7	5.8	V
High Voltage of COUT pin Output	V_{COH2}	$I_{COH}=50\mu A, V_{Celln}=4.7V$ (n=1, 2, 3)	$V_{COH1}-0.5$	$V_{COH1}-0.1$	-	V
Low Voltage of COUT pin Output	V_{CL}	$I_{COH}=50\mu A, V_{Celln}=3.9V$ (n=1, 2, 3)	-	0.1	0.5	V

Description:

*1. n=1, 2, 3.

*2. The parameters within this temperature range are design guarantee values instead of screened values from high, low temperature measurement.

*3. Vcelln is voltage of Cell-n, n=1, 2, 3.

Table 6 HY2131-BF1A Electrical Parameters (VSS = 0V, Ta = 25 °C, unless indicated otherwise)

Item	Symbol	Conditions	Min.	Typ.	Max.	Unit
Input Voltage						
VDD-VSS Operating Voltage	V_{DSOP1}	-	3.6	-	30	V
Current Consumption						
Operating Current	I_{DD}	$V_{C1}=V_{C2}=V_{C3}=3.9V$	-	3.0	6.0	μA
Standby Current	I_{PD}	$V_{C1}=V_{C2}=V_{C3}=3.1V$	-	0.3	0.5	μA
Detection Voltage						
Overcharge Detection Voltage n (*1)	V_{CUn}		4.430	4.450	4.470	V
		-5 °C ~ 55 °C (*2)	4.425	4.450	4.475	V
Overcharge Release Voltage n (*1)	V_{CRn}		4.100	4.150	4.200	V
Standby Detection Voltage	V_{SB}		3.1	3.5	3.9	V
Delay Time						
Overcharge Detection Delay Time	T_{OCn}	$V_{Celln}=3.9V, V_{Cell1}=3.9V \rightarrow 4.7V$ (*3)	4.8	6.0	7.2	s
Overcharge Release Delay Time	T_{CRn}	$V_{Celln}=3.9V, V_{Cell1}=4.7V \rightarrow 3.9V$ (*3)	12.8	16	19.2	ms
Reset Delay Time of Overcharge Detection Counter	T_{DTR}	$V_{Celln}=V_{CUn}+0.050V \rightarrow V_{CRn}-0.100V \rightarrow V_{CUn}+0.050V \rightarrow V_{CRn}-0.100V$	2	6	10	Ms
Control Pin Output Voltage						
High Voltage of COU1 pin Output	V_{COH1}	$I_{COH}=0\mu A, V_{Celln}=4.7V$ (n=1, 2, 3)	4.0	4.7	5.4	V
High Voltage of COU2 pin Output	V_{COH2}	$I_{COH}=50\mu A, V_{Celln}=4.7V$ (n= 1, 2, 3)	$V_{COH1}-0.5$	$V_{COH1}-0.1$	-	V
Low Voltage of COU pin Output	V_{CL}	$I_{COH}=50\mu A, V_{Celln}=3.9V$ (n=1, 2, 3)	-	0.1	0.5	V

Description:

*1. n=1, 2, 3.

*2. The parameters within this temperature range are design guarantee values instead of screened values from high, low temperature measurement.

*3. Vcelln is voltage of Cell-n, n=1, 2, 3.

Table 7 HY2131-BF1A Electrical Parameters (VSS = 0V, Ta = -40~85 °C (*2), unless indicated otherwise)

Item	Symbol	Condition	Min.	Typ.	Max.	Unit
Input Voltage						
VDD-VSS Operating Voltage	V_{DSOP1}	-	3.6	-	30	V
Current Consumption						
Operating Current	I_{DD}	$V_{C1}=V_{C2}=V_{C3}=3.9V$	-	3.0	6.6	μA
Standby Current	I_{PD}	$V_{C1}=V_{C2}=V_{C3}=3.1V$	-	0.3	0.8	μA
Detection Voltage						
Overcharge Detection Voltage n (*1)	V_{CUn}		4.411	4.450	4.484	V
Overcharge Release Voltage n (*1)	V_{CRn}		4.082	4.150	4.218	V
Standby Detection Voltage	V_{SB}		2.96	3.5	3.94	V
Delay Time						
Overcharge Detection Delay Time	T_{OCn}	$V_{Celln}=3.9V, V_{Cell1}=3.9V \rightarrow 4.7V$ (*3)	3.1	6.0	9.4	s
Overcharge Release Delay Time	T_{CRn}	$V_{Celln}=3.9V, V_{Cell1}=4.7V \rightarrow 3.9V$ (*3)	8.5	16	25.2	ms
Reset Delay Time of Overcharge Detection Counter	T_{DTR}	$V_{Celln}=V_{CUn}+0.050V \rightarrow V_{CRn}-0.100V \rightarrow V_{CUn}+0.050V \rightarrow V_{CRn}-0.100V$	0.04	6	11.5	ms
Control Pin Output Voltage						
High Voltage of COUT pin Output	V_{COH1}	$I_{COH}=0\mu A, V_{Celln}=4.7V$ (n=1, 2, 3)	3.6	4.7	5.8	V
High Voltage of COUT pin Output	V_{COH2}	$I_{COH}=50\mu A, V_{Celln}=4.7V$ (n=1, 2, 3)	$V_{COH1}-0.5$	$V_{COH1}-0.1$	-	V
Low Voltage of COUT pin Output	V_{CL}	$I_{COH}=50\mu A, V_{Celln}=3.9V$ (n=1, 2, 3)	-	0.1	0.5	V

Description:

*1. n=1, 2, 3.

*2. The parameters within this temperature range are design guarantee values instead of screened values from high, low temperature measurement.

*3. Vcelln is voltage of Cell-n, n=1, 2, 3.

Table 8 HY2131-CF1A Electrical Parameters (VSS = 0V, Ta = 25 °C, unless indicated otherwise)

Item	Symbol	Conditions	Min.	Typ.	Max.	Unit
Input Voltage						
VDD-VSS Operating Voltage	V _{DSOP1}	-	3.6	-	30	V
Current Consumption						
Operating Current	I _{DD}	V _{C1} =V _{C2} =V _{C3} =3.9V	-	3.0	6.0	μA
Standby Current	I _{PD}	V _{C1} =V _{C2} =V _{C3} =3.1V	-	0.3	0.5	μA
Detection Voltage						
Overcharge Detection Voltage n (*1)	V _{CUn}		4.380	4.400	4.420	V
		-5 °C ~ 55 °C (*2)	4.375	4.400	4.425	V
Overcharge Release Voltage n (*1)	V _{CRn}		4.050	4.100	4.150	V
Standby Detection Voltage	V _{SB}		3.1	3.5	3.9	V
Delay Time						
Overcharge Detection Delay Time	T _{OCn}	V _{Celln} =3.9V, V _{Cell1} =3.9V → 4.7V (*3)	4.8	6.0	7.2	s
Overcharge Release Delay Time	T _{CRn}	V _{Celln} = 3.9V, V _{Cell1} =4.7V → 3.9V (*3)	12.8	16	19.2	ms
Reset Delay Time of Overcharge Detection Counter	T _{DTR}	V _{Celln} = V _{CUn} +0.050V → V _{CRn} -0.100V → V _{CUn} +0.050V → V _{CRn} -0.100V	2	6	10	ms
Control Pin Output Voltage						
High Voltage of COUT pin Output	V _{COH1}	I _{COH} =0μA, V _{Celln} =4.7V (n=1, 2, 3)	4.0	4.7	5.4	V
High Voltage of COUT pin Output	V _{COH2}	I _{COH} =50μA, V _{Celln} =4.7V (n=1, 2, 3)	V _{COH1} -0.5	V _{COH1} -0.1	-	V
Low Voltage of COUT pin Output	V _{CL}	I _{COH} =50μA, V _{Celln} =3.9V (n=1, 2, 3)	-	0.1	0.5	V

Description:

*1. n=1, 2, 3.

*2. The parameters within this temperature range are design guarantee values instead of screened values from high, low temperature measurement.

*3. Vcelln is voltage of Cell-n, n=1, 2, 3.

Table 9 HY2131-CF1A Electrical Parameters (VSS = 0V, Ta = -40~85 °C (*2), unless indicated otherwise)

Item	Symbol	Condition	Min.	Typ.	Max.	Unit
Input Voltage						
VDD-VSS Operating Voltage	V _{DSOP1}	-	3.6	-	30	V
Current Consumption						
Operating Current	I _{DD}	V _{C1} =V _{C2} =V _{C3} =3.9V	-	3.0	6.6	μA
Standby Current	I _{PD}	V _{C1} =V _{C2} =V _{C3} =3.1V	-	0.3	0.8	μA
Detection Voltage						
Overcharge Detection Voltage n (*1)	V _{CU_n}		4.361	4.400	4.434	V
Overcharge Release Voltage n (*1)	V _{CR_n}		4.032	4.100	4.168	V
Standby Detection Voltage	V _{SB}		2.96	3.5	3.94	V
Delay Time						
Overcharge Detection Delay Time	T _{OC_n}	V _{Cell_n} =3.9V, V _{Cell1} =3.9V→4.7V (*3)	3.1	6.0	9.4	s
Overcharge Release Delay Time	T _{CR_n}	V _{Cell_n} =3.9V, V _{Cell1} =4.7V → 3.9V (*3)	8.5	16	25.2	ms
Reset Delay Time of Overcharge Detection Counter	T _{DTR}	V _{Cell_n} =V _{CU_n} +0.050V→V _{CR_n} -0.100V→V _{CU_n} +0.050V→V _{CR_n} -0.100V	0.04	6	11.5	ms
Control Pin Output Voltage						
High Voltage of COUT pin Output	V _{COH1}	I _{COH} =0μA, V _{Cell_n} =4.7V (n=1, 2, 3)	3.6	4.7	5.8	V
High Voltage of COUT pin Output	V _{COH2}	I _{COH} =50μA, V _{Cell_n} =4.7V (n=1, 2, 3)	V _{COH1} -0.5	V _{COH1} -0.1	-	V
Low Voltage of COUT pin Output	V _{CL}	I _{COH} =50μA, V _{Cell_n} =3.9V (n=1, 2, 3)	-	0.1	0.5	V

Description:

*1. n=1, 2, 3.

*2. The parameters within this temperature range are design guarantee values instead of screened values from high, low temperature measurement.

*3. Vcelln is voltage of Cell-n, n=1, 2, 3.

Table 10 HY2131-DF1A Electrical Parameters (VSS = 0V, Ta = 25 °C, unless indicated otherwise)

Item	Symbol	Conditions	Min.	Typ.	Max.	Unit
Input Voltage						
VDD-VSS Operating Voltage	V _{DSOP1}	-	3.6	-	30	V
Current Consumption						
Operating Current	I _{DD}	V _{C1} =V _{C2} =V _{C3} =3.9V	-	3.0	6.0	μA
Standby Current	I _{PD}	V _{C1} =V _{C2} =V _{C3} =3.1V	-	0.3	0.5	μA
Detection Voltage						
Overcharge Detection Voltage n (*1)	V _{CU_n}		4.480	4.500	4.520	V
		-5 °C ~ 55 °C (*2)	4.475	4.500	4.525	V
Overcharge Release Voltage n (*1)	V _{CR_n}		4.150	4.200	4.250	V
Standby Detection Voltage	V _{SB}		3.1	3.5	3.9	V
Delay Time						
Overcharge Detection Delay Time	T _{OC_n}	V _{Cell_n} =3.9V, V _{Cell1} =3.9V→4.7V (*3)	4.8	6.0	7.2	s
Overcharge Release Delay Time	T _{CR_n}	V _{Cell_n} =3.9V, V _{Cell1} =4.7V→3.9V (*3)	12.8	16	19.2	ms
Reset Delay Time of Overcharge Detection Counter	T _{DTR}	V _{Cell_n} =V _{CU_n} +0.050V → V _{CR_n} -0.100V → V _{CU_n} +0.050V → V _{CR_n} -0.100V	2	6	10	ms
Control Pin Output Voltage						
High Voltage of COUT pin Output	V _{COH1}	I _{COH} =0μA, V _{Cell_n} =4.7V (n=1, 2, 3)	4.0	4.7	5.4	V
High Voltage of COUT pin Output	V _{COH2}	I _{COH} =50μA, V _{Cell_n} =4.7V (n=1, 2, 3)	V _{COH1} -0.5	V _{COH1} -0.1	-	V
Low Voltage of COUT pin Output	V _{CL}	I _{COH} =50μA, V _{Cell_n} =3.9V (n=1, 2, 3)	-	0.1	0.5	V

Description:

*1. n=1, 2, 3.

*2. The parameters within this temperature range are design guarantee values instead of screened values from high, low temperature measurement.

*3. V_{cell_n} is voltage of Cell-n, n=1, 2, 3.

Table 11 HY2131-DF1A Electrical Parameters ($V_{SS} = 0V$, $T_a = -40\sim 85\text{ }^\circ\text{C}$ (*2), unless indicated otherwise)

Item	Symbol	Condition	Min.	Typ.	Max.	Unit
Input Voltage						
VDD-VSS Operating Voltage	V_{DSOP1}	-	3.6	-	30	V
Current Consumption						
Operating Current	I_{DD}	$V_{C1}=V_{C2}=V_{C3}=3.9V$	-	3.0	6.6	μA
Standby Current	I_{PD}	$V_{C1}=V_{C2}=V_{C3}=3.1V$	-	0.3	0.8	μA
Detection Voltage						
Overcharge Detection Voltage n (*1)	V_{CUn}		4.461	4.500	4.534	V
Overcharge Release Voltage n (*1)	V_{CRn}		4.132	4.200	4.268	V
Standby Detection Voltage	V_{SB}		2.96	3.5	3.94	V
Delay Time						
Overcharge Detection Delay Time	T_{OCn}	$V_{Celln}=3.9V$, $V_{Cell1}=3.9V\rightarrow 4.7V$ (*3)	3.1	6.0	9.4	s
Overcharge Release Delay Time	T_{CRn}	$V_{Celln}=3.9V$, $V_{Cell1}=4.7V\rightarrow 3.9V$ (*3)	8.5	16	25.2	ms
Reset Delay Time of Overcharge Detection Counter	T_{DTR}	$V_{Celln}=V_{CUn}+0.050V\rightarrow V_{CRn}-0.100V\rightarrow V_{CUn}+0.050V\rightarrow V_{CRn}-0.100V$	0.04	6	11.5	ms
Control Pin Output Voltage						
High Voltage of COUT pin Output	V_{COH1}	$I_{COH}=0\mu A$, $V_{Celln}=4.7V$ (n=1, 2, 3)	3.6	4.7	5.8	V
High Voltage of COUT pin Output	V_{COH2}	$I_{COH}=50\mu A$, $V_{Celln}=4.7V$ (n=1, 2, 3)	$V_{COH1}-0.5$	$V_{COH1}-0.1$	-	V
Low Voltage of COUT pin Output	V_{CL}	$I_{COH}=50\mu A$, $V_{Celln}=3.9V$ (n=1, 2, 3)	-	0.1	0.5	V

Description:

*1. n=1, 2, 3.

*2. The parameters within this temperature range are design guarantee values instead of screened values from high, low temperature measurement.

*3. Vcelln is voltage of Cell-n, n=1, 2, 3.

Table 12 HY2131-EF1A Electrical Parameters (VSS = 0V, Ta = 25 °C, unless indicated otherwise)

Item	Symbol	Conditions	Min.	Typ.	Max.	Unit
Input Voltage						
VDD-VSS Operating Voltage	V_{DSOP1}	-	3.6	-	30	V
Current Consumption						
Operating Current	I_{DD}	$V_{C1}=V_{C2}=V_{C3}=3.9V$	-	3.0	6.0	μA
Standby Current	I_{PD}	$V_{C1}=V_{C2}=V_{C3}=3.1V$	-	0.3	0.5	μA
Detection Voltage						
Overcharge Detection Voltage n (*1)	V_{CU_n}		4.530	4.550	4.570	V
		-5 °C ~ 55 °C (*2)	4.525	4.550	4.575	V
Overcharge Release Voltage n (*1)	V_{CR_n}		4.200	4.250	4.300	V
Standby Detection Voltage	V_{SB}		3.1	3.5	3.9	V
Delay Time						
Overcharge Detection Delay Time	T_{OC_n}	$V_{Cell_n}=3.9V, V_{Cell_1}=3.9V \rightarrow 4.7V$ (*3)	4.8	6.0	7.2	s
Overcharge Release Delay Time	T_{CR_n}	$V_{Cell_n}=3.9V, V_{Cell_1}=4.7V \rightarrow 3.9V$ (*3)	12.8	16	19.2	ms
Reset Delay Time of Overcharge Detection Counter	T_{DTR}	$V_{Cell_n}=V_{CU_n}+0.050V \rightarrow V_{CR_n}-0.100V \rightarrow V_{CU_n}+0.050V \rightarrow V_{CR_n}-0.100V$	2	6	10	ms
Control Pin Output Voltage						
High Voltage of COU _T pin Output	V_{COH1}	$I_{COH}=0\mu A, V_{Cell_n}=4.7V$ (n=1, 2, 3)	4.0	4.7	5.4	V
High Voltage of COU _T pin Output	V_{COH2}	$I_{COH}=50\mu A, V_{Cell_n}=4.7V$ (n=1, 2, 3)	$V_{COH1}-0.5$	$V_{COH1}-0.1$	-	V
Low Voltage of COU _T pin Output	V_{CL}	$I_{COH}=50\mu A, V_{Cell_n}=3.9V$ (n=1, 2, 3)	-	0.1	0.5	V

Description:

*1: n=1, 2, 3.

*2: The parameters within this temperature range are design guarantee values instead of screened values from high, low temperature measurement.

*3: V_{celln} is voltage of Cell-n, n=1, 2, 3.

Table 13 HY2131-EF1A Electrical Parameters (VSS = 0V, Ta = -40~85 °C (*2), unless indicated otherwise)

Item	Symbol	Condition	Min.	Typ.	Max.	Unit
Input Voltage						
VDD-VSS Operating Voltage	V_{DSOP1}	-	3.6	-	30	V
Current Consumption						
Operating Current	I_{DD}	$V_{C1}=V_{C2}=V_{C3}=3.9V$	-	3.0	6.6	μA
Standby Current	I_{PD}	$V_{C1}=V_{C2}=V_{C3}=3.1V$	-	0.3	0.8	μA
Detection Voltage						
Overcharge Detection Voltage n (*1)	V_{CUn}		4.511	4.550	4.584	V
Overcharge Release Voltage n (*1)	V_{CRn}		4.182	4.250	4.318	V
Standby Detection Voltage	V_{SB}		2.96	3.5	3.94	V
Delay Time						
Overcharge Detection Delay Time	T_{OCn}	$V_{Celln}=3.9V, V_{Cell1}=3.9V \rightarrow 4.7V$ (*3)	3.1	6.0	9.4	s
Overcharge Release Delay Time	T_{CRn}	$V_{Celln}=3.9V, V_{Cell1}=4.7V \rightarrow 3.9V$ (*3)	8.5	16	25.2	ms
Reset Delay Time of Overcharge Detection Counter	T_{DTR}	$V_{Celln}=V_{CUn}+0.050V \rightarrow V_{CRn}-0.100V \rightarrow V_{CUn}+0.050V \rightarrow V_{CRn}-0.100V$	0.04	6	11.5	ms
Control Pin Output Voltage						
High Voltage of COUT pin Output	V_{COH1}	$I_{COH}=0\mu A, V_{Celln}=4.7V$ (n=1, 2, 3)	3.6	4.7	5.8	V
High Voltage of COUT pin Output	V_{COH2}	$I_{COH}=50\mu A, V_{Celln}=4.7V$ (n=1, 2, 3)	$V_{COH1}-0.5$	$V_{COH1}-0.1$	-	V
Low Voltage of COUT pin Output	V_{CL}	$I_{COH}=50\mu A, V_{Celln}=3.9V$ (n=1, 2, 3)	-	0.1	0.5	V

Description:

*1. n=1, 2, 3.

*2. The parameters within this temperature range are design guarantee values instead of screened values from high, low temperature measurement.

*3. Vcelln is voltage of Cell-n, n=1, 2, 3.

11. Example of Application Circuit for Battery Protection IC

11.1. 3-Cell in Series Connection

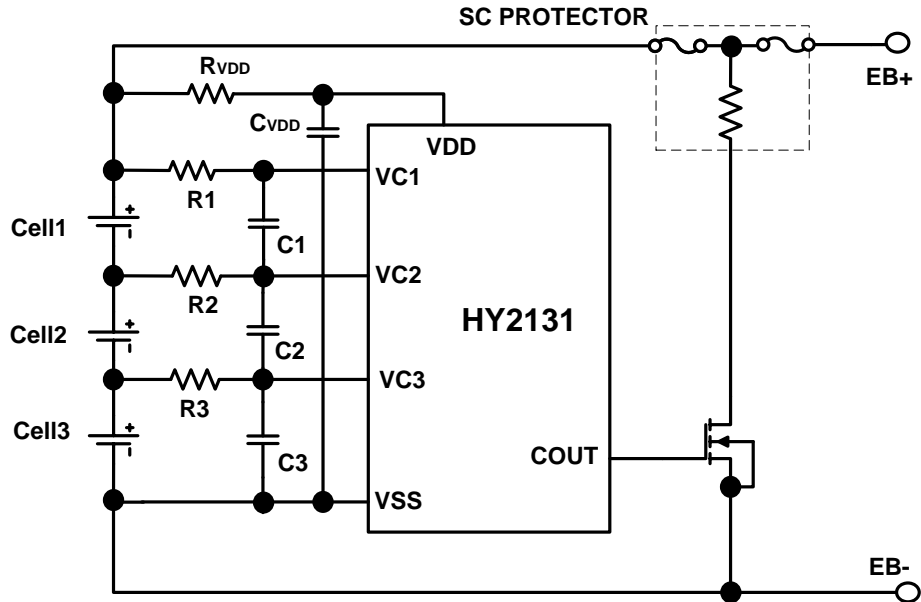

11.2. 2-Cell in Series Connection

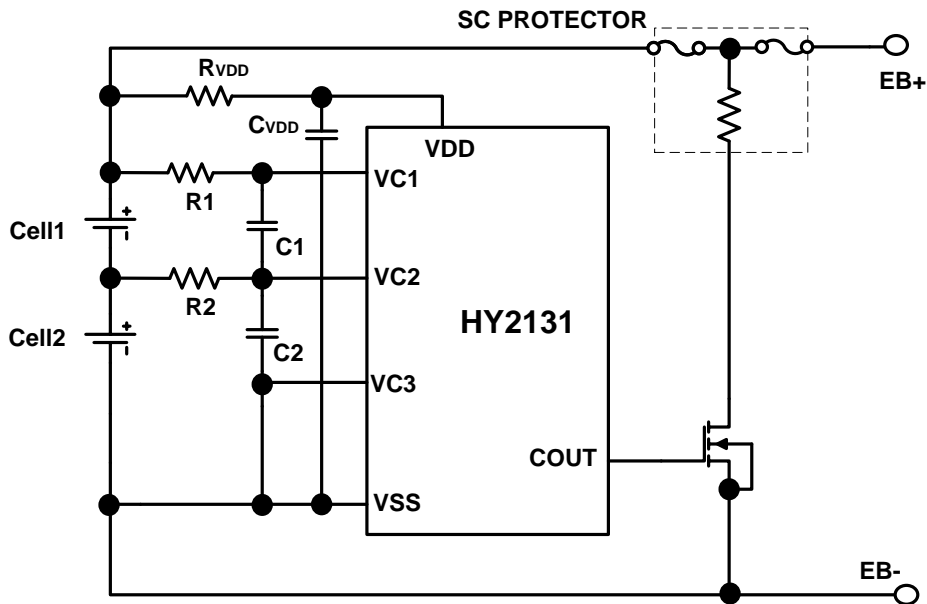

In terms of the order of connecting cells, the positive terminal of the cell 1 should be the last. Otherwise, COUT may output “H” tentatively, and the fuse may be fused, but IC is not damaged. Connect sequences must be used as following:

3-series cell configuration

Cell3 -> Cell2 -> Cell1

Cell2 -> Cell3 -> Cell1

2-series cell configuration

Cell2 -> Cell1

Symbol	Device Name	Purpose	Min.	Typ.	Max.	Remark
RVDD	Resistor	Limiting current, stabilizing VDD	100Ω	100Ω	1KΩ	*1
R1~R3	Resistor	Limiting current	330Ω	1kΩ	1kΩ	*2
CVDD	Capacitor	Filtering, stabilizing VDD	0.01μF	0.1μF	1.0μF	*1
C1~C3	Capacitor		0.01μF	0.1μF	1.0μF	*2

*1. RVDD and CVDD are capable of VDD voltage stabilization. If RVDD is connected with an over small resistor, IC operation may be unstable because there is larger fluctuation on Cell voltage due to current. If RVDD is connected with an over large resistor, unpredicted result may be resulted from voltage difference between voltages on VDD pin and VC1 pin because of voltage difference across RVDD due to current consumption of the IC itself. Therefore, RVDD is ranged from 100Ω ~ 1KΩ and CVDD is ranged from 0.01μF ~ 1.0μF, and never connect capacitor below 0.01μF.

*2. R1 ~ R3 and C1 ~ C3 are capable of stabilizing voltages of cell1 ~ cell3. If R1 ~ R3 are connected to over large resistor, detection voltage precision would be impacted because of voltage difference due to current consumption. Therefore, R1 ~ R3 should be connected with resistor below 1KΩ, and C1 ~ C3 should be connected with capacitor equal to or above 0.01μF.

- The typical application circuit diagram above is only for reference. The performance of the circuit depends on PCB layout and external components to a great extent. Sufficient evaluation and test are necessary in real application.
- Both overvoltage and over-current shall not exceed the absolute maximum values of the IC and its peripheral devices. As overcharge protection status is detected, large current would flow through FET until the fuse is broken. In order to guarantee undamaged FET, the current resistance value for the FET should be sufficiently large.
- If SC protection is to be connected, it has to be connected to the battery as the last one. In connecting cell, the positive pole of Cell1 has to be connected as the last one. Otherwise, COUT pin might output high level to result in fused Fuse. The SC protector is Zip code 141-0032 (Sony Chemical & Information Device Company Ltd.).

Caution :

- The parameters above may be changed without announce in advance. Please download the latest version of Specification from our website.

HY2131

Protection IC for 2/3-Cell Lithium Ion/Lithium Polymer Batteries in Series



Our website is: <http://www.hycontek.com>.

2. If peripheral devices are to be adjusted, customers are recommended to conduct sufficient evaluation and test in advance.

12. Description of Operation

12.1. Overcharge Status

This IC detects voltage of battery 1 connected between V_{C1} and V_{C2} pins, voltage of battery 2 connected between V_{C2} and V_{C3} pins and voltage of battery 3 connected between V_{C3} and VSS continuously to control charging. When voltage of one battery is higher than or equal to the overcharge detection voltage (V_{CUn}) and the sustaining time of such status is larger than or equal to the overcharge detection delay time (T_{OCn}), the output voltage on COUT pin of the IC becomes high level from low level, such that the MOSFET for charging control is switched off, and charging is stopped. Such status is referred to as “overcharge status”.

Overcharge status release: When the voltages of battery 1, battery 2 and battery 3 are all lower than or equal to the overcharge release voltage (V_{CRn}) and the sustaining time of such status is larger than or equal to the overcharge release delay time (T_{CRn}), the output voltage on COUT pin of the IC becomes low level from high level, such that the overcharge status is released and normal operating status is returned.

Caution:

- (1) The overcharge delay time is a built-in fixed output. If the overcharge detection counter is reset, the overcharge protection status would be released and the normal status would be returned.
- (2) The IC would still enter the overcharge protection status even though only the voltage of one battery keeps higher than the overcharge detection voltage and the sustaining time is beyond the overcharge detection delay time.
- (3) If the voltage of one battery is higher than the overcharge detection voltage due to noise or other causes while the voltages of batteries 1, 2 and 3 are all lower than the overcharge detection voltage in the overcharge detection delay time, the sustained period of time with voltage higher than the overcharge detection voltage would be retained and accumulated. As the accumulated time is larger than the overcharge detection delay time, the IC would enter “overcharge status”.
- (4) After overcharge protection, the overcharge protection status would not be released if the voltage of at least one battery is higher than the overcharge release voltage in the overcharge release delay time even though the voltages of all batteries are equal to or lower than the overcharge release voltage.
- (5) The output type of COUT pin is active high CMOS. The output voltage is between VSS and the output voltage of internal regulator. The high level is provided by the internal regulator with 4.7 V as typical value.

12.2. Standby Status

As the voltages of batteries 1, 2 and 3 are all lowered to the standby detection voltage (V_{SB}), the current consumption of the IC is reduced to the current consumption value in standby, which status is referred to as “standby status”, for battery in normal operating status in a discharging process. At the moment, the maximum value of current consumption is 0.5 μ A. After the IC enters the standby status, the standby status would be released and the normal operating status would be returned whenever the voltage of a certain battery is higher than or equal to the standby detection voltage (V_{SB}).

12.3. Test Time Shortening Capability

In addition to the voltage under detection, the test time for overcharge protection delay time and the overcharge release delay time of the battery under detection may be reduced by shorting the positive and negative poles of the other two batteries.

Table 5 – Description of Short Connection for Capability of Shortening Test Time

Battery under Test with Respect to Shortening of Delay Time	Description of Short Connection
Battery 1	V_{C2} and V_{C3} pins are shorted, V_{C3} and V_{SS} pins are shorted
Battery 2	V_{C1} and V_{C2} pins are shorted, V_{C3} and V_{SS} pins are shorted
Battery 3	V_{C1} and V_{C2} pins are shorted, V_{C2} and V_{C3} pins are shorted

13. Timing Diagram

(1) Overcharge Detection

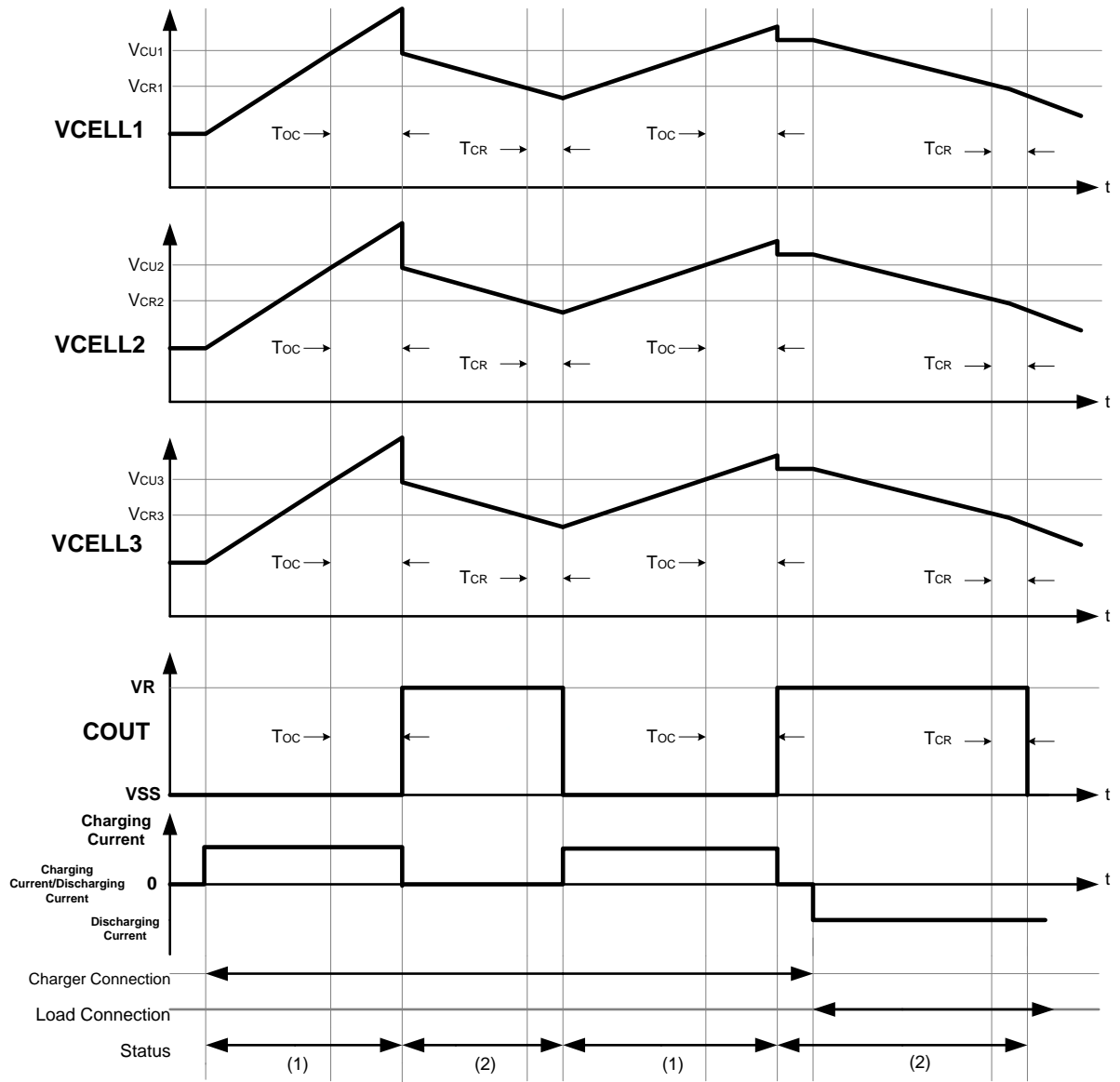

Description: (1) Normal operating status, (2) Overcharge Status

14. Package Information

14.1. TSOT-23-6 Package

Note: All dimensions are in millimeters.

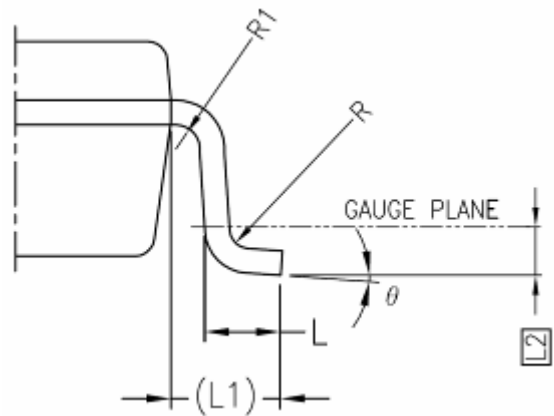
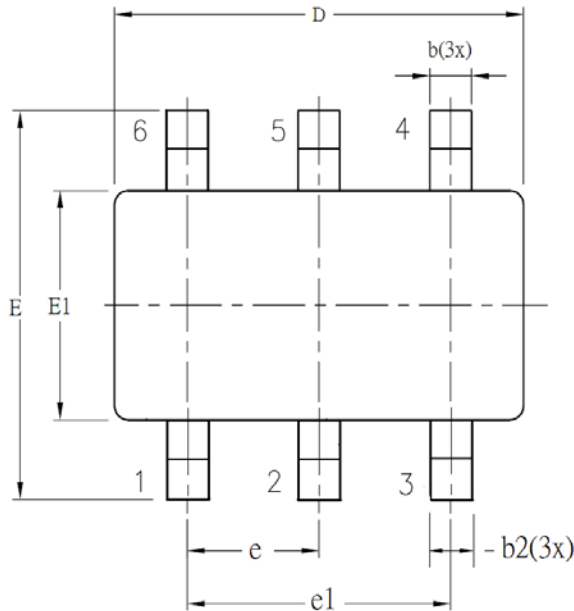

SYM BOL	ALL DIMENSIONS IN MILLIMETERS		
	MINIMUM	NOMINAL	MAXIMUM
A	-	0.8	0.9
A1	0	-	0.15
A2	-	0.7	0.8
b	0.30	-	0.50
b1	0.30	0.40	0.45
b2	0.30	0.40	0.50
c	0.08	-	0.22
c1	0.08	0.13	0.20
D	2.90 ± 0.2 BSC		
E	2.80 ± 0.02 BSC		
E1	1.60 +0.2 or -0.1 BSC		
e	0.95 BSC		
e1	1.90 BSC		
L	0.30	0.45	0.60
L1	0.60 REF		
L2	0.25 BSC		
R	0.10	-	-
R1	0.10	-	0.25
θ	0°	4°	8°
$\theta 1$	5°	-	15°
$\theta 2$	5°	-	15°

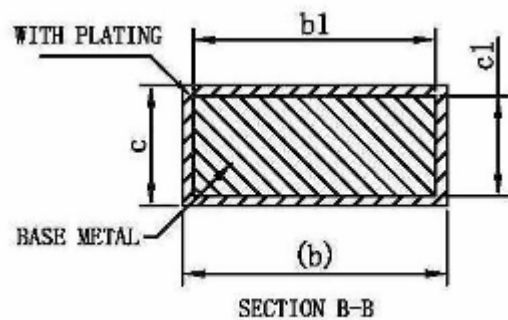
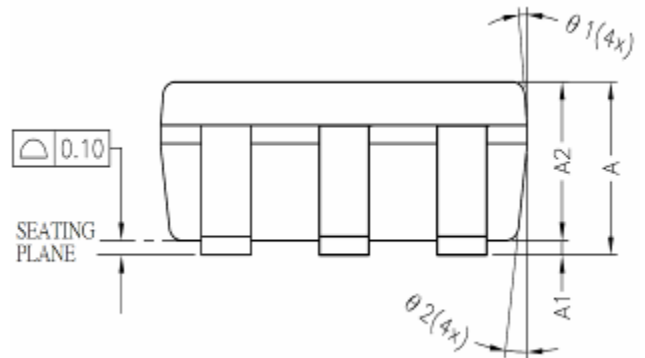

15. Tape & Reel Information

15.1. Tape & Reel Information---TSOT-23-6

Unit : mm

15.1.1. Reel Dimensions

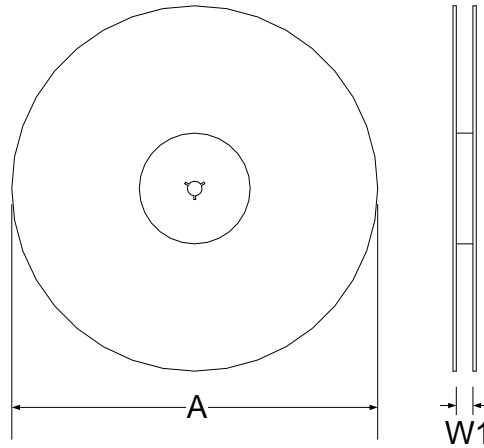

15.1.2. Carrier Tape Dimensions

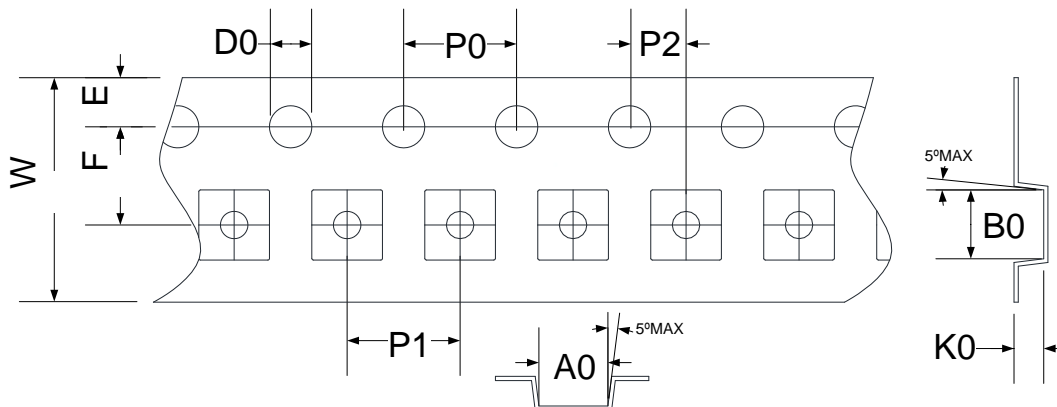

SYMBOLS	Reel Dimensions		Carrier Tape Dimensions									
	A	W1	A0	B0	K0	P0	P1	P2	E	F	D0	W
Spec.	178	9.4	3.17	3.23	1.37	4.00	4.00	2.00	1.75	3.50	1.55	8.00
Tolerance	±2.00	±1.50	±0.10	±0.10	±0.10	±0.10	±0.10	±0.05	±0.10	±0.05	±0.05	+0.30/-0.10

Note: 10 Sprocket hole pitch cumulative tolerance is ±0.20mm.

15.1.3. Pin1 direction

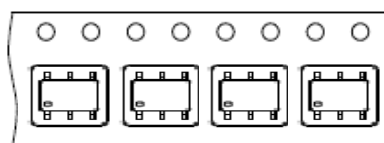

16. Revision Record

The larger modifications of this document are described below, but changes of punctuation marks and fonts are not within the scope of description.

Version	Page	Summary of Modification
V01	-	First release.
V02	All	New models are included. Refer to pages 6, 10, 11 and 12 in detail. Added tape and reel information please refer to page 19.
V03	All	Revise HY2131-BF1A, HY2131-CF1A, HY2131-DF1A, HY2131-EF1A delay time code and TOC.
V04	All	Added -40~85 °C Electronic Specification, CH 8 Test circuit, Revised CH11, Revised CH 14.