



HY461x
Data Sheet
True Multi-Touch Capacitive Touch Panel Controller
V30

Table of Contents

1. TYPICAL APPLICATIONS	5
2. OVERVIEW	5
. 2.1 BLOCK DIAGRAM	6
. 2.2 OPERATION MODES	6
. 2.3 HOST INTERFACE	7
. 2.4 IIC	7
3. ELECTRONIC SPECIFICATIONS	9
. 3.1 ABSOLUTE MAXIMUM RATINGS	9
. 3.2 DC CHARACTERISTICS	9
. 3.3 AC CHARACTERISTICS	10
. 3.5 POWER SEQUENCE	10
4. PIN CONFIGURATIONS	12
5. PACKAGE INFORMATION	14
. 5.1 PACKAGE OUTLINE DRAWING--- QFN 6x6 48PIN	16
. 5.2. PACKAGE OUTLINE DRAWING--- QFN 6x6 56PIN	17
. 5.3 PACKAGE OUTLINE DRAWING--- QFN 8x8 68PIN	18
6. ORDER INFORMATION	19
7. HISTORY	20

Attention:

1. HYCON Technology Corp. reserves the right to change the content of this datasheet without further notice. For most up-to-date information, please constantly visit our website: <http://www.hycontek.com> .
2. HYCON Technology Corp. is not responsible for problems caused by figures or application circuits narrated herein whose related industrial properties belong to third parties.
3. Specifications of any HYCON Technology Corp. products detailed or contained herein stipulate the performance, characteristics, and functions of the specified products in the independent state. We does not guarantee of the performance, characteristics, and functions of the specified products as placed in the customer's products or equipment. Constant and sufficient verification and evaluation is highly advised.
4. Please note the operating conditions of input voltage, output voltage and load current and ensure the IC internal power consumption does not exceed that of package tolerance. HYCON Technology Corp. assumes no responsibility for equipment failures that resulted from using products at values that exceed, even momentarily, rated values listed in products specifications of HYCON products specified herein.
5. Notwithstanding this product has built-in ESD protection circuit, please do not exert excessive static electricity to protection circuit.
6. Products specified or contained herein cannot be employed in applications which require extremely high levels of reliability, such as device or equipment affecting the human body, health/medical equipments, security systems, or any apparatus installed in aircrafts and other vehicles.
7. Despite the fact that HYCON Technology Corp. endeavors to enhance product quality as well as reliability in every possible way, failure or malfunction of semiconductor products may happen. Hence, users are strongly recommended to comply with safety design including redundancy and fire-precaution equipments to prevent any accidents and fires that may follow.
8. Use of the information described herein for other purposes and/or reproduction or copying without the permission of HYCON Technology Corp. is strictly prohibited.

Introduction

The HY461x Series ICs are single-chip capacitive touch panel controller ICs with a built-in 32-bit Micro-controller unit (MCU). They adopt the mutual capacitance approach, which supports true multi-touch capability. In conjunction with a mutual capacitive touch panel, the HY461x have user-friendly input functions, and embedded flash memory. The touch solution supports IIC and SPI interfaces for most of the devices as cellular phone, e-book, tablet, portable devices.

FEATURES

- Mutual Capacitive Sensing Techniques
- True Multi-touch with up to 11 Points of Absolution X and Y Coordinates
- 32-Bit Micro-controller for Algorithm Execution
- Supports precise 16-Bit ADCs for input signal collection
- Supports Auto-Calibration function to prevent Environmental Variations
- Supports up to 28 Transmit Lines (TXs) and 16 Receive Lines (RXs)
 - HY4613-N048: 21 Transmit Lines (TXs) and 12 Receive Lines (RXs)
 - HY4614-N056: 26 Transmit Lines (TXs) and 16 Receive Lines (RXs)
 - HY4614-N068: 28 Transmit Lines (TXs) and 16 Receive Lines (RXs)
- Supports more than 100Hz High Report Rate
- Optional IIC interfaces supported
- Supports wide Voltage operation range: 2.6V to 3.6V
- Supports direct communication connect: 1.8V/AVDD IOVCC
- Capable of Driving Single Channel (transmit/receive) Resistance: Up to 30K Ω
- Capable of Supporting Single Channel (transmit/receive) Capacitance: 60 pF
- Optimal Sensing Mutual Capacitor: 1pF~4pF
- Immune to RF and power noise Interferences
- Gloved finger operation and waterproof function
- Supports auto-calibration function to prevent environmental variations
- Classifying and rejecting unintended touch, e.g., a resting hand on the screen
- Realize touch screen, buttons and proximity
- Low Power Modes Supported: Active, Standby, and Sleep
- Operating Temperature Range: -40°C to +85°C
- Support Pb-free package

1. Typical Applications

HY461x accommodate a wide range of applications with a set of buttons up to a 2D touch sensing device, their typical applications as listed below.

- Mobile phones, smart phones
- Tablet PC
- Navigation systems, GPS
- Game consoles
- Car applications
- POS (Point of Sales) devices
- Portable MP3 and MP4 media players
- Digital cameras

2. Overview

HY461x Series ICs support < 10.1 inch Touch Panel, users may find out their target IC from the specs listed in the following table,

Model Name	Panel		Package			Touch Panel Size	Status
	TX	RX	Type	Pin	Size		
HY4613-N048	21	12	QFN	48	6mm*6mm	< 5.3"	M/P
HY4614-N056	26	16	QFN	56	6mm*6mm	5.3"~7"	M/P
HY4614-N068	28	16	QFN	68	8mm*8mm	7"~10.1"	M/P

2.1 Block Diagram

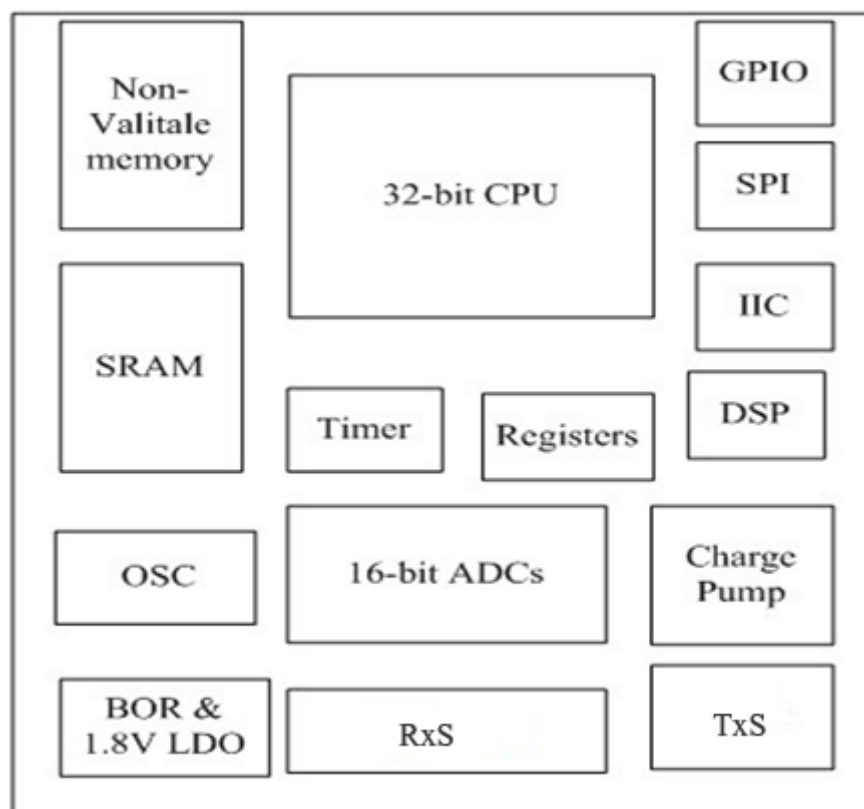

HY461x System Architecture Diagram

2.2 Operation Modes

HY461x operates in the following three modes:

Active mode:

When in this mode, HY461x actively scans the panel. The default scan rate is 80 frames per second. The host processor can configure HY461x to speed up or to slow down.

Standby Mode:

When in this mode, HY461x scans the panel at a reduced speed. The default scan rate is 20 frames per second and the host processor can increase or decrease this rate. When in this mode, most algorithms are stopped. A simpler algorithm is being executed to determine if there is a touch or not. When a touch is detected, HY461x shall enter the Active mode immediately to acquire the touch information quickly. During this mode, the serial port is closed and no data shall be transferred with the host processor.

Sleep Mode

In this mode, the chip is set in a power down mode, therefore consumes very little current. It shall only respond to the "RESET" signal from the host processor.

2.3 Host Interface

The serial interface of HY461x is IIC. The details of this interface are described in detail as below figure. The interrupt signal (/INT) is used for HY461x to inform the host that data are ready for the host to receive. The /RESET signal is used for the host to wake up HY461x from the Sleep mode. After exiting the Sleep mode, HY461x shall enter the Active mode.

2.4 IIC

The IIC is always configured in the Slave mode. The data transfer format is showed in the following figure.

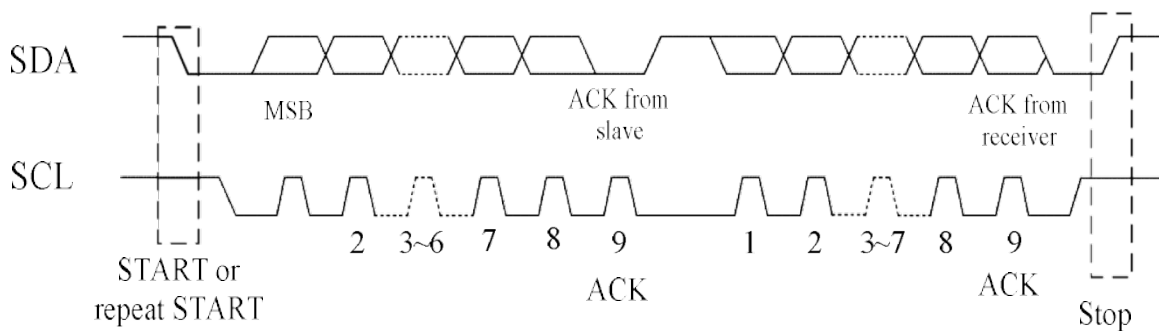

Figure 2-1 IIC Serial Data Transfer Format

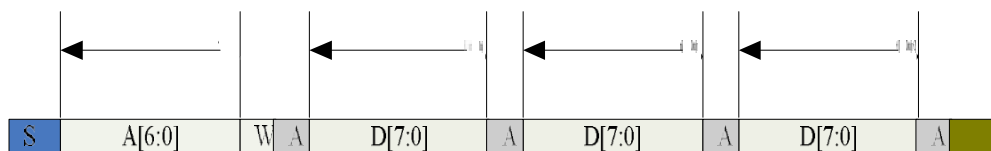

Figure 2-2, IIC master write, slave read

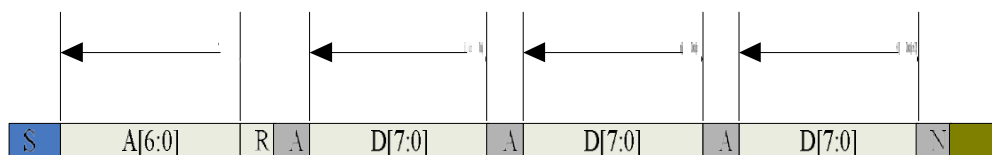

Figure 2-3 IIC master read, slave write

Table 1 Mnemonics Description

Mnemonics	Description
S	IIC Start or IIC Restart
A	Slave address A[7:1]: Slave address A[0]: read or write bit
W	Bit0 = 0 : Write
R	Bit0 = 1: Read
A(N)	ACK(NACK)
P	STOP: the indication of the end of a packet (if this bit is missing, S will indicate the end of the current packet and the beginning of the next packet)

IIC Interface Timing Characteristics is shown in Table 2

Table 2 IIC Timing Characteristics

Parameter	Unit	Min	Max
SCL frequency	KHz	--	400
Bus free time between a STOP and START condition	us	1.3	--
Hold time (repeated) START condition	us	0.6	--
Data setup time	ns	100	--
Setup time for a repeated START condition	us	0.6	--
Setup Time for STOP condition	us	0.6	--

3. Electronic Specifications

3.1 Absolute Maximum Ratings

Table 3-1 Absolute Maximum Ratings

Item	Symbol	Unit	Value
Power Supply Voltage 1	VDDA - VSSA	V	-0.2 V to 4.0 V
Power Supply Voltage 2	VDD3 - VSS	V	-0.2 V to 4.0 V
I/O Power Supply Voltage	Vt	V	-0.2 V to 4.0 V
Operating Temperature	Topr	°C	-40°C to 85°C
Storage Temperature	Tstg	°C	-55°C to 110°C

3.2 DC Characteristics

Table 3-2 DC Characteristics

Item	Symbol	Unit	Test Condition	Min.	Typ.	Max.
Input high-level voltage	VIH	V	--	--	0.7*VDD3	--
Input low-level voltage	VIL	V	--	--	0.3*VDD3	--
Output high-level voltage	VOH	V	IOH=10mA	VDD3-0.3V	--	--
Output low-level voltage	VOL	V	IOH=-10mA	--	--	VSS+0.3V
I/O leakage current	ILI	μA	Vin=0~VDDA	--	--	0.1
Active mode	Iact	mA	VDDA=3.3V Ta=25°C MCLK=17MHz	--	8	--
Standby mode	Istby	mA	VDDA=3.3V Ta=25°C MCLK=17MHz	--	3	--
Sleep mode	Islp	mA	--	--	0.02	--
Power Supply voltage	VDDA	V	--	2.6	3.3	3.6

3.3 AC Characteristics

Table 3-3 AC Characteristics of Oscillators

Item	Symbol	Unit	Condition	Min.	Typ	Max.
OSC clock 1	Fosc1	MHz	VDD3 = 3.3V Ta=25°C	--	17	--
OSC clock 2	Fosc2	KHz	VDD3 = 3.3V Ta=25°C	--	140	--

Table 3-4 AC Characteristic

Item	Symbol	Unit	Condition	Min.	Typ	Max.
TX acceptable clock	ftx	KHz	--	--	--	250
Charge Pump voltage	Vcp	V	--	2.6	--	5.2

3.5 Power Sequence

Power Rise Timing:

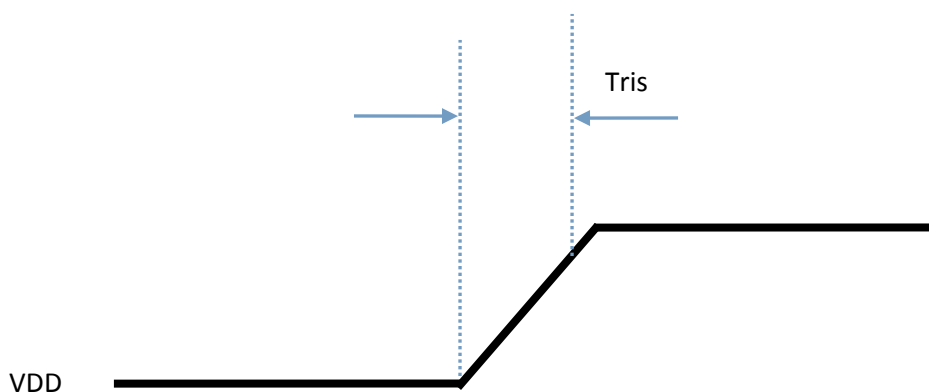

Power On / Off Timing:

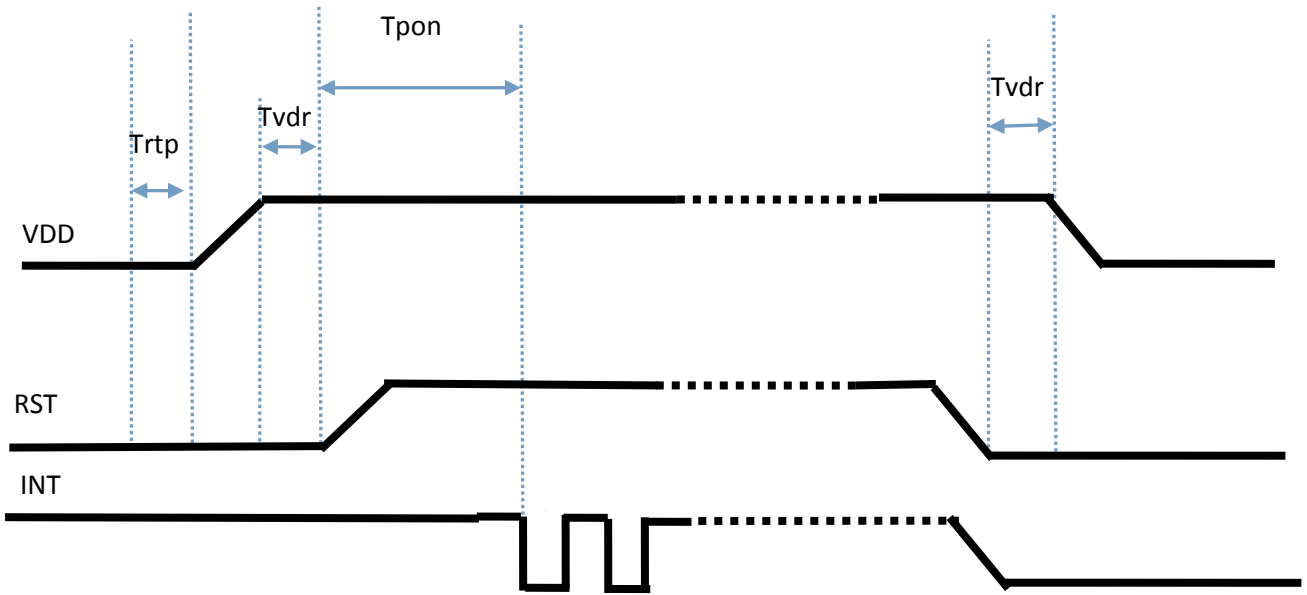

Reset Sequence:

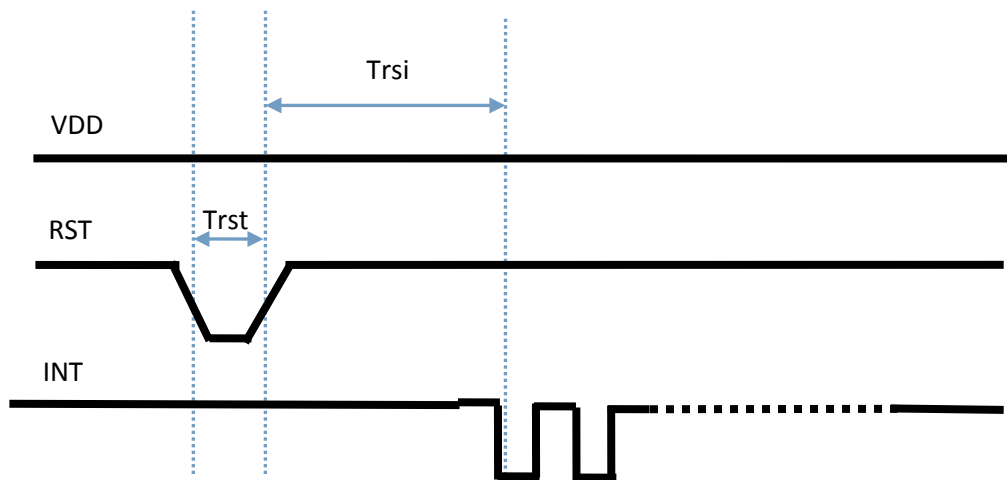

Parameter	Description	Min	Max	Uints
Tris	Rise time from 0.1VDD to 0.9VDD		5	ms
Trtp	Time of resetting to be low before powering on	100		us
Tpon	Time of starting to report point after powering on	200		ms
Tvdr	Reset time after VDD powering on	1		ms
Trsi	Time of starting to report point after resetting	200		ms
Trst	Reset time	2		ms

4. PIN Configurations

Name	HY4613- N048	HY4614- N056	HY4614- N068	I/O	Description
VSSA	1	56	1	PI	ADC/Charge Amplifier Ground
TX28			4	AO	Transmit output pin
TX27			5	AO	Transmit output pin
TX26		1	6	AO	Transmit output pin
TX25		2	7	AO	Transmit output pin
TX24		3	8	AO	Transmit output pin
TX23		4	9	AO	Transmit output pin
TX22		5	10	AO	Transmit output pin
TX21	2	6	11	AO	Transmit output pin
TX20	3	7	12	AO	Transmit output pin
TX19	4	8	13	AO	Transmit output pin
TX18	5	9	14	AO	Transmit output pin
TX17	6	10	15	AO	Transmit output pin
TX16	7	11	16	AO	Transmit output pin
TX15	8	12	17	AO	Transmit output pin
TX14	9	13	18	AO	Transmit output pin
TX13	10	14	19	AO	Transmit output pin
TX12	11	15	20	AO	Transmit output pin
TX11	12	16	21	AO	Transmit output pin
TX10	13	17	22	AO	Transmit output pin
TX9	14	18	23	AO	Transmit output pin
TX8	15	19	24	AO	Transmit output pin
TX7	16	20	25	AO	Transmit output pin
TX6	17	21	26	AO	Transmit output pin
TX5	18	22	27	AO	Transmit output pin
TX4	19	23	28	AO	Transmit output pin
TX3	20	24	29	AO	Transmit output pin
TX2	21	25	30	AO	Transmit output pin
TX1	22	26	31	AO	Transmit output pin
VDD5	23	27	32	PO	Charge pump LDO output, 1uF Cap to Ground
VDD3	24	28	33	PI	Analog power supply
VSS	25	29	34	PI	Analog Ground
VDD18	26	30	35	PO	1.8V LDO OUTPUT, 1uF Cap to Ground

Name	HY4613- N048	HY4614- N056	HY4614- N068	I/O	Description
Test	27	31	36	DI	Test mode enabled at high and float in normal mode
VDDA	35	39	52	PI	ADC/Charge Amplifier Power
RX1	36	40	53	AI	Receiver input pin
NC	48		2\3\48\49\ 50\51		
RX2	37	41	54	AI	Receiver input pin
RX3	38	42	55	AI	Receiver input pin
RX4	39	43	56	AI	Receiver input pin
RX5	40	44	57	AI	Receiver input pin
RX6	41	45	58	AI	Receiver input pin
RX7	42	46	59	AI	Receiver input pin
RX8	43	47	60	AI	Receiver input pin
RX9	44	48	61	AI	Receiver input pin
RX10	45	49	62	AI	Receiver input pin
RX11	46	50	63	AI	Receiver input pin
RX12	47	51	64	AI	Receiver input pin
RX13		52	65	AI	Receiver input pin
RX14		53	66	AI	Receiver input pin
RX15		54	67	AI	Receiver input pin
RX16		55	68	AI	Receiver input pin
GPIO_0			37	DIO	General Input / Output port
GPIO_1			38	DIO	General Input / Output port
GPIO_2			39	DIO	General Input / Output port
GPIO_3			40	DIO	General Input / Output port
SCL	28	32	41	DIO	I2C clock input , active low
SCK	29	33	42	DI	SPI Slave mode, clock input
MOSI/SDA	30	34	43	DIO	I2C data input , active low
MISO	31	35	44	DIO	SPI Slave mode, data output
RST	32	36	45	DI	External Reset, Low is active
WAKE	33	37	46	DI	Eternal interrupt from the host
INT	34	38	47	DO	Eternal interrupt to the host

5. Package Information

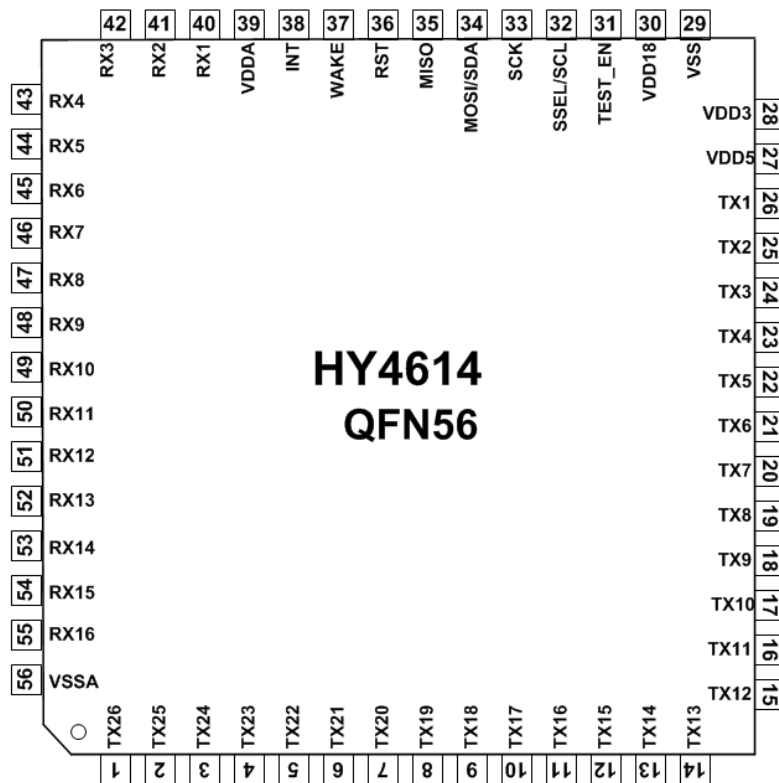
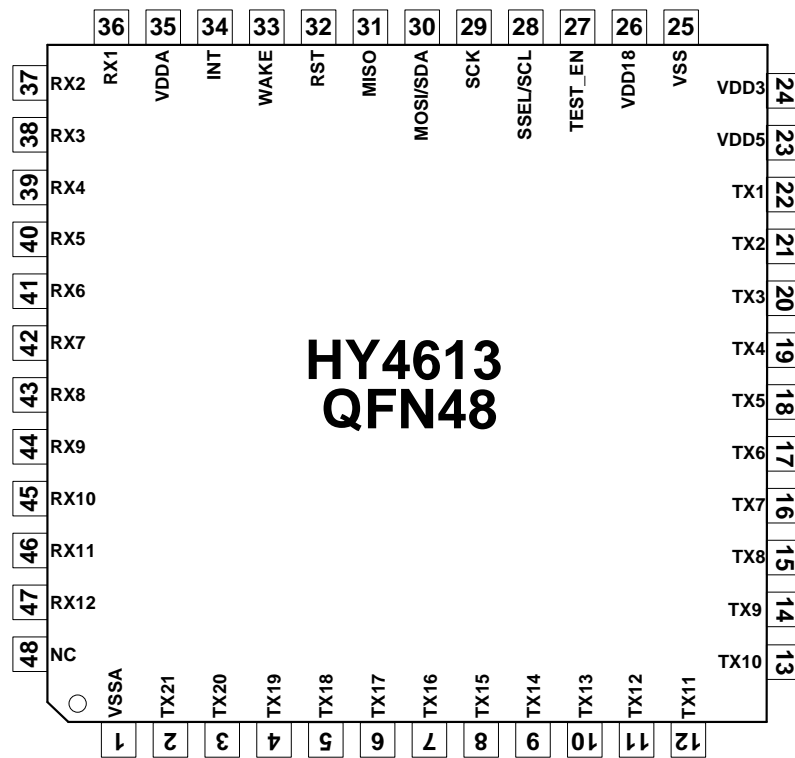

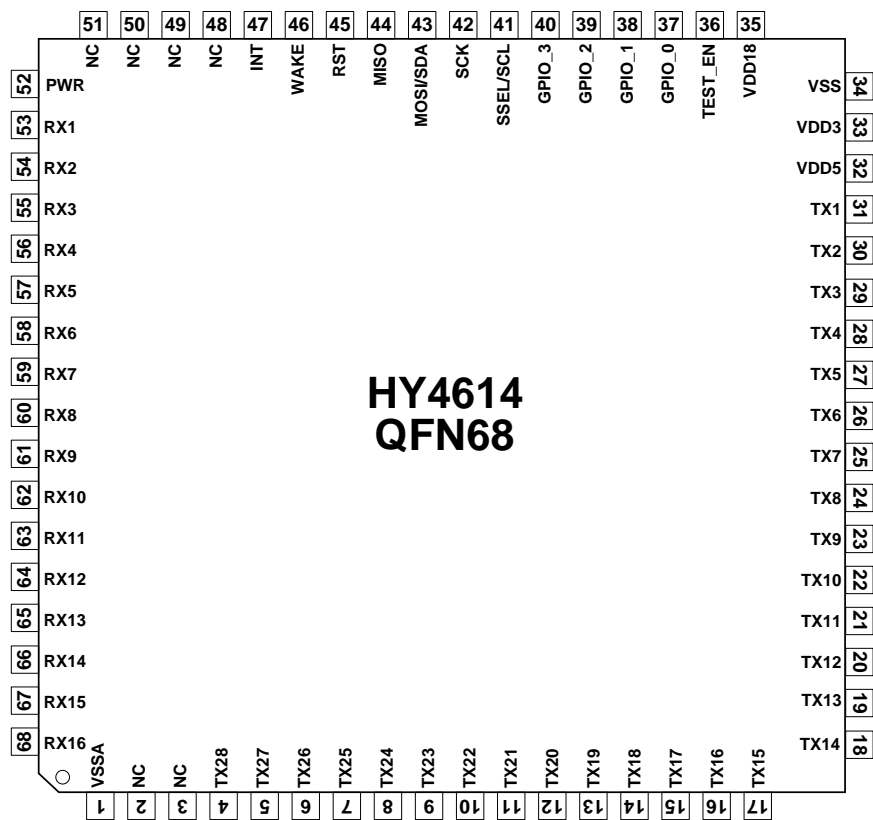

5.1 Package Outline Drawing--- QFN 6x6 48pin

Unit : mm

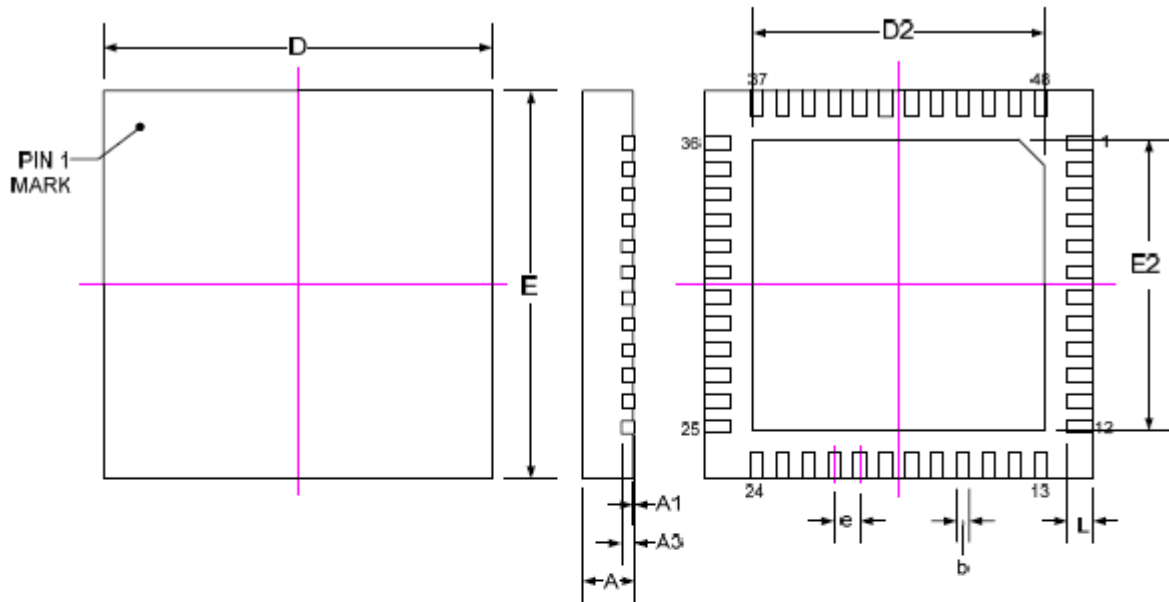

SYMBOLS	MIN	NOM	MAX
A	0.70	0.75	0.80
A1	0.00	0.02	0.05
A3	0.20 REF.		
b	0.15	0.20	0.25
D	6.00 BSC		
E	6.00 BSC		
D2	4.40	4.50	4.55
E2	4.40	4.50	4.55
L	0.35	0.40	0.45
e	0.40 BSC		

Note: All dimensions refer to JEDEC OUTLINE MO-220.

5.2. Package Outline Drawing--- QFN 6x6 56pin

Unit : mm

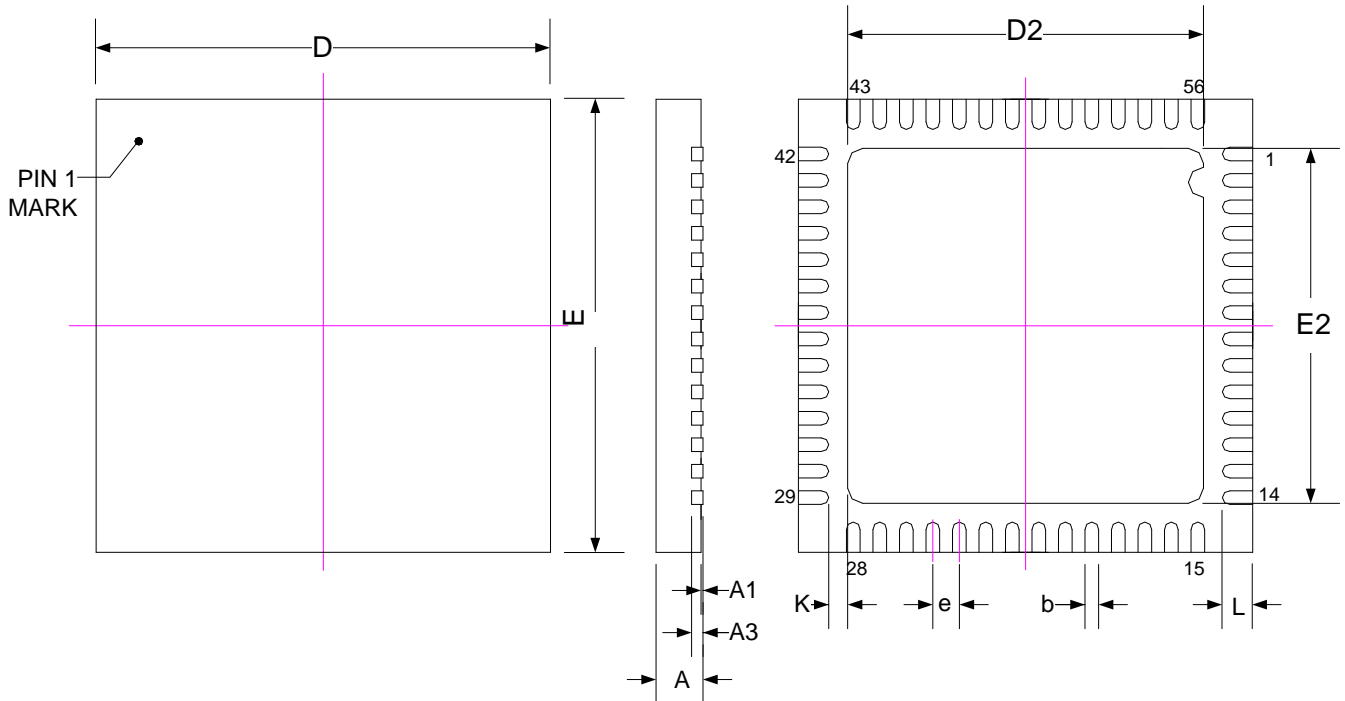

SYMBOLS	MIN	NOM	MAX
A	0.50	0.55	0.60
A1	0.00	0.02	0.05
A3	0.15 REF.		
b	0.13	0.18	0.23
D	6.00 BSC		
E	6.00 BSC		
e	0.35 BSC		
D2	4.65	4.70	4.75
E2	4.65	4.70	4.75
L	0.35	0.40	0.45
K	0.20	0.25	0.30

5.3 Package Outline Drawing--- QFN 8x8 68pin

Unit : mm

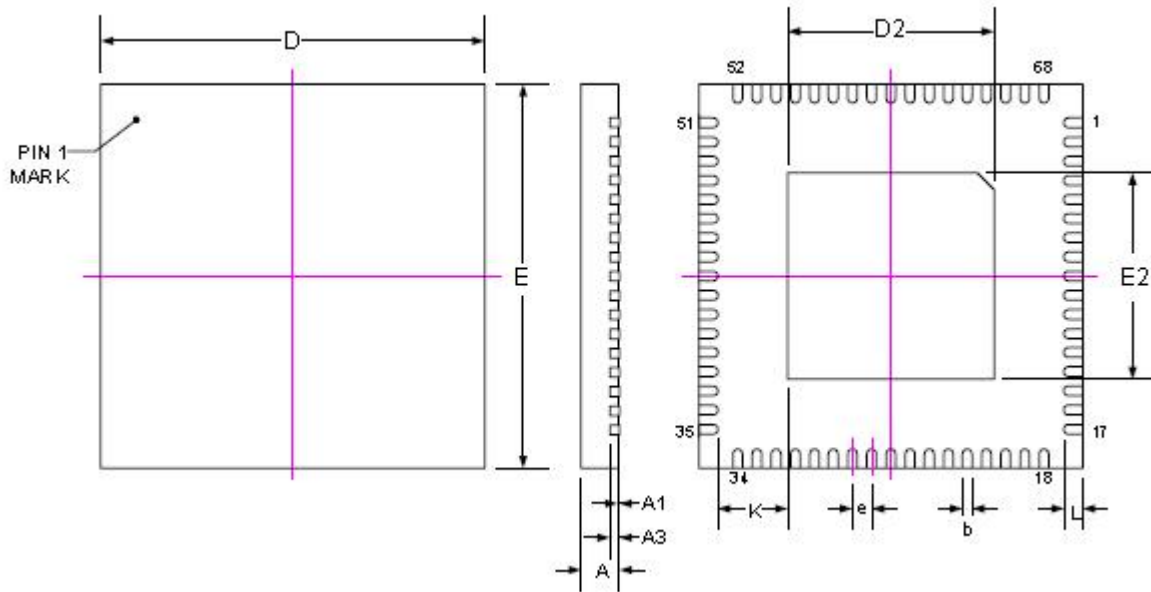

SYMBOLS	MIN	NOM	MAX
A	0.70	0.75	0.80
A1	0.00	0.02	0.05
A3	0.20 REF.		
b	0.15	0.20	0.25
D	8.00 BSC		
E	8.00 BSC		
e	0.40 BSC		
D2	4.20	4.30	4.40
E2	4.20	4.30	4.40
L	0.35	0.40	0.45
K	1.35	1.45	1.55

Note: All dimensions refer to JEDEC OUTLINE MO-220.

6. Order Information

Device No	Package Type	Pins	Package Drawing	Shipment Packing Type	Unit Q'ty	Material Composition	MSL ³
HY4613-N048	QFN	48	N048	Tray / TR	490 / 3K	Green4	MSL-3
HY4614-N056	QFN	56	N056	Tray / TR	348 / 3K	Green4	MSL-3
HY4614-N068	QFN	68	N068	Tray / TR	348 / 3K	Green4	MSL-3

1. Device No.: Model No. – Package Type Description

EX : You request in QFN 48 package.

The device No. will be HY4613-N048

And please clearly indicate the shipment packing type when placing orders.

2. MSL:

The Moisture Sensitivity Level ranking conforms to IPC/JEDEC J-STD-020 industry standard categorization.

The products are processed, packed, transported and used with reference to IPC/JEDEC J-STD-033.

3. Green (RoHS & no Cl/Br):

HYCON products are Green products that compliant with RoHS directive and are Halogen free (Br/Cl<0.1%).

7. History

Version	Date	Purpose	Pages
V1.0	2013/10/15	First Version	ALL
V2.0	2014/3/20	Second Version	ALL
V2.1	2015/01/07	a. Tpon and Trsi revise b. Phase out HY4615- N068 chip	Page11/12/13/14
V2.2	2015/03/20	a. OSC clock1/2 revise b. Remove HY4616- N088 chip	Page10/12/13/14/16
V3.0	2015/03/25	Third Version	ALL