

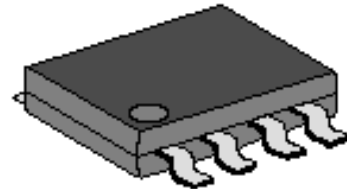

## Features

- Precision Reference Voltage: 5.0V ( $\pm 1\%$ )
- Low start-up current: typ. 50uA
- High current totem pole output: typ. 700mA
- Internal temperature compensated oscillator
- Double pulse suppression
- UVLO with Hysteresis function
- Oscillator Frequency: Max. 500KHz
- Package: PDIP8 / SOP8



SOP8

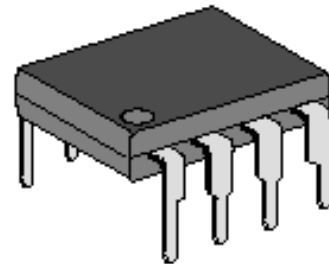

PDIP8

## General Description

The **HY5002**, a 1-chip composed of high-current totem pole output circuits with a PWM latch, current sense comparator and an error amplifier, the **HY5002** contains a 5V precision voltage reference regulator, under-voltage lockout circuit (UVLO), oscillator circuit and a green power function, applied to offer space and low cost in many applications such as the DC/DC converter and off-line AC adaptor or switching power supply.



## Typical Application Circuit

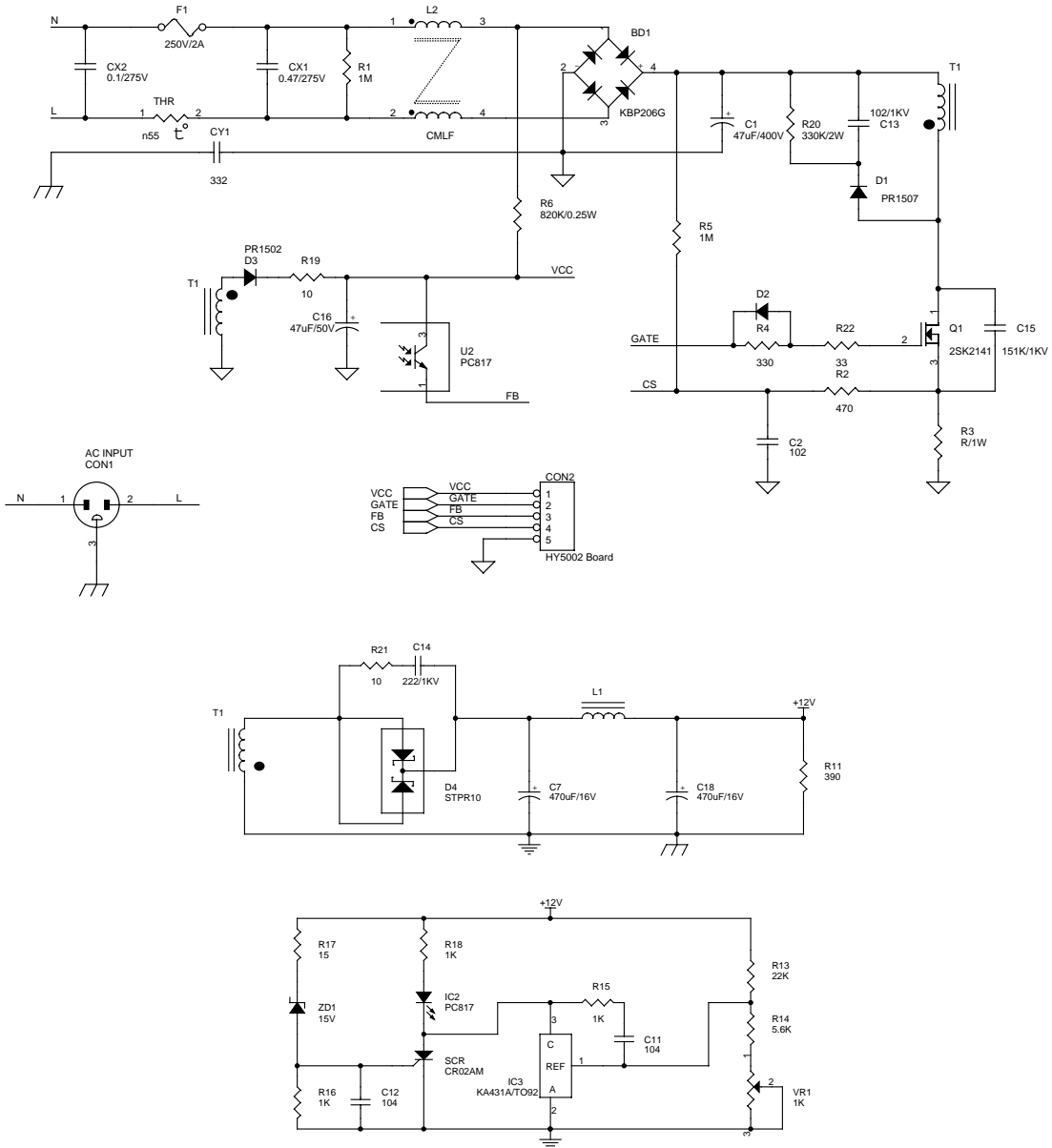

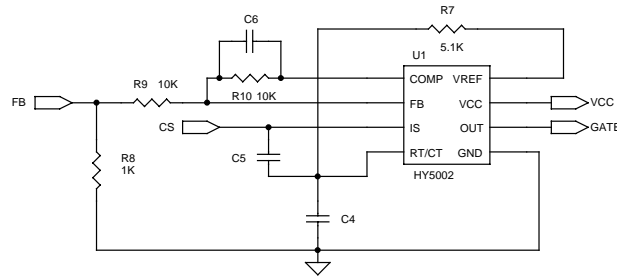

## Functional Block Diagram

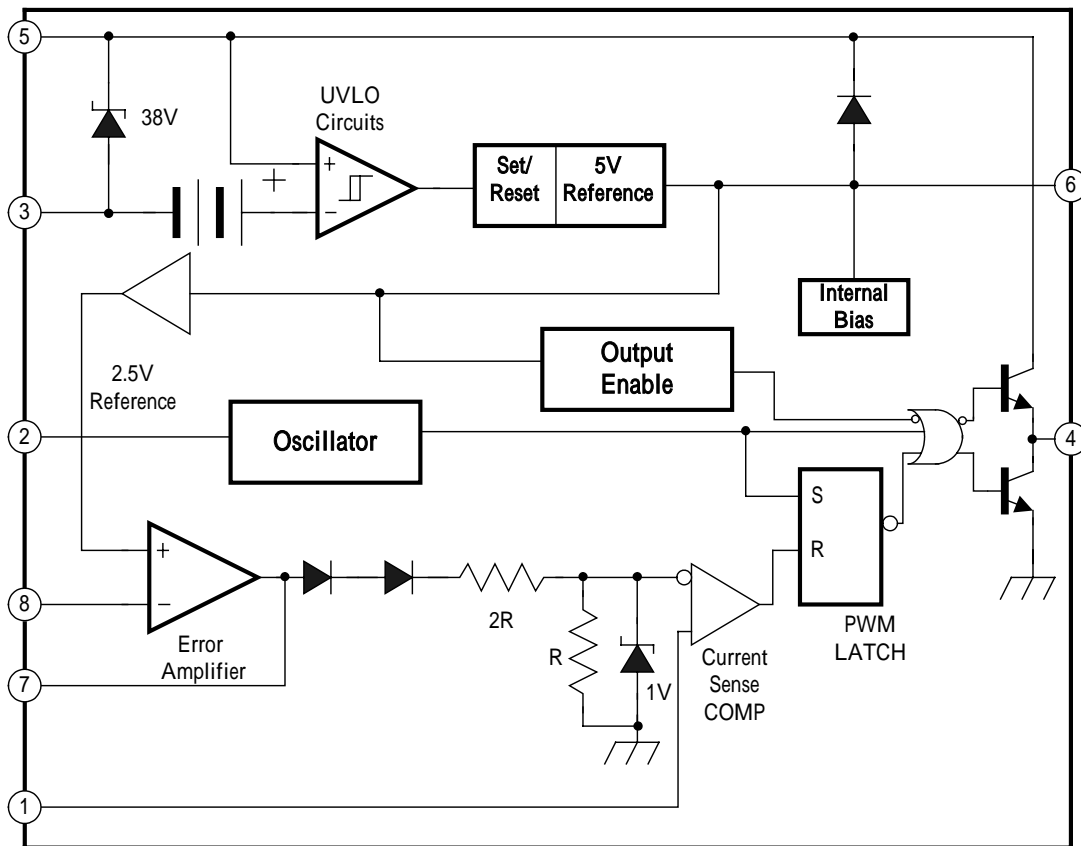



### MARK VIEW

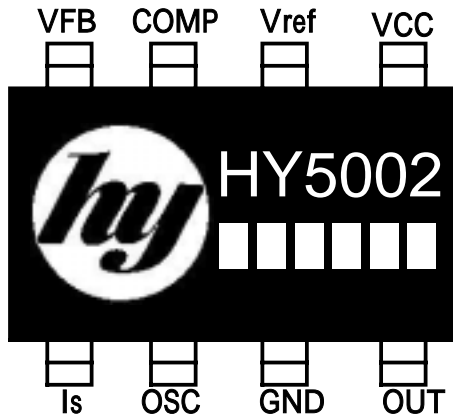

### PIN DESCRIPTION

NAME	STATUS	DESCRIPTION
Is	I	Current Sense Input
OSC	I	RC Network for Oscillator
GND	P	IC Ground
OUT	O	Totem Pole Output Drive for MOSFET
VCC	P	IC Power Supply
Vref	O	5.0V Reference Output
COMP	O	Error Amplifier Feedback Output
VFB	I	Error Amplifier Inverting Input

### IC Date Code Distinguish

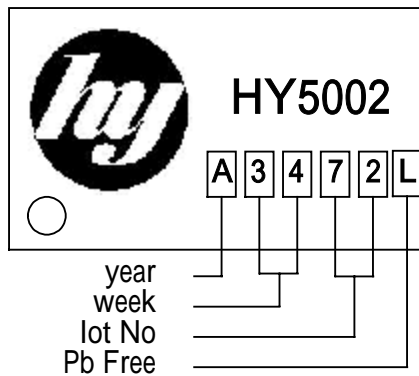

Logo: Hawyang logo

Product name: HY5002 (for example)

D/C: A34

A – year 2001, B – year 2002, C – year 2003

34 – week

72 – lot no. Last 2 codes

### Order Information

Part Number	Operating Temperature	Package	Description
HY5002DLF	-20 85	SOP8	Tube
HY5002DLF(R)	-20 85	SOP8	Tape & Reel
HY5002PLF	-20°C 85°C	PDIP8	Tube (1%)



## Absolute Maximum Ratings

Symbol	Parameter	Rating
V <sub>CC</sub>	Supply Voltage	+30 V
V <sub>FB</sub>	Analog Input Voltage	-0.3 V +5.5V
V <sub>o</sub>	Output Voltage	+30 V
I <sub>o</sub>	Output Current	±1 A
T <sub>j</sub>	Maximum Junction Temperature	150
SOP package	Thermal Resistance Junction to Ambient	175 /W
PDIP package	Thermal Resistance Junction to Ambient	100 /W
SOP8 package	Power Dissipation	
	T <sub>a</sub> =25	650mW
	T <sub>a</sub> =70	550mW
	Operating Temperature Range	-20 85
	Storage Temperature Range	-65 150
soldering, 10 sec	Lead Temperature	+230

## Electrical Characteristics

Electrical characteristics over recommended operating temperature range , V<sub>CC</sub> = 15V ,

R<sub>T</sub>=10K,C<sub>T</sub>=3.3nF,0 T<sub>A</sub> 70 ,unless otherwise noted

### Reference

PARAMETER	SYMBOL	TEST CONDITIONS	MIN	TYP	MAX	UNIT
Output voltage	V <sub>REF</sub>	COMP connected to FB	4.9	5.0	5.1	V
Input regulation	V <sub>REF</sub>	V <sub>CC</sub> = 3.6 V to 40 V		6.0	20	mV
Output voltage change with temperature	V <sub>REF</sub> /V <sub>REF</sub>	T <sub>A</sub> = -20 to 25	-10	-1	15	mV/V
		T <sub>A</sub> = 25 to 85	-10	-2	10	

†All typical values are at T<sub>A</sub> = 25 .



### Under voltage lockout

PARAMETER	SYMBOL	TEST CONDITIONS	MIN	TYP	MAX	UNIT
Start Threshold	$V_{TH(ST)r}$	$T_A = 25$	7.9	8.4	9.0	V
Minimum Operating Voltage	$V_{OPR(MIN)}$	After Turn On	7.1	7.6	8.1	V

†All typical values are at  $T_A = 25$  .

### Oscillator

PARAMETER	SYMBOL	TEST CONDITIONS	MIN	TYP	MAX	UNIT
Frequency	f	$C_t=3.3nF, R_t = 100K$	47	52	57	KHz
Frequency change with voltage	f/ V	$V_{CC} = 12V$ to 25V		0.05	1.0	%
Frequency change with temperature	f/ T	$T_A = -20$ to 25	-4	-0.4	4	KHz
		$T_A = 25$ to 85	-4	-0.2	4	KHz
Amplitude	$V_{p-p}$ of OSC Pin			1.7		V

†All typical values are at  $T_A = 25$  .

### Error amplifier

PARAMETER	SYMBOL	TEST CONDITIONS	MIN	TYP	MAX	UNIT
Input voltage	$V_{IN}$	$V_{FB} = 3V$	2.43	2.5	2.58	V
Input bias current	$V_{BIAS}$			-0.1	-2.0	uA
Open-loop voltage amplification	$A_{VO}$		65	90		dB
Unity-gain bandwidth	$BW_U$		0.7	1.0		MHz
Power Supply Rejection Ratio	PSRR	12V $V_{CC}$ 25V	60	70		Db
Output ( sink ) current	$I_{SINK}$	$V_{I(FB)} = 2.7V$ , COMP = 1.1V	2	7		mA
Output ( source ) current	$I_{SOURCE}$	$V_{I(FB)} = 2.3V$ , COMP = 5V	-0.5	-1.0		mA
$V_{COMP}$ High Voltage	$V_{OH}$	$V_{I(FB)} = 2.3V$ , $R_L = 15K$ to GND	5.0	6.0		V
$V_{COMP}$ Low Voltage	$V_{OH}$	$V_{I(FB)} = 2.7V$ , $R_L = 15K$ to $V_{ref}$		0.7	1.1	V

†All typical values are at  $T_A = 25$  .



Electrical characteristics over recommended operating temperature range ,  $V_{CC} = 15V$  ,  
 $R_T=10K, C_T=3.3nF, 0 \leq T_A \leq 70$  , unless otherwise noted ( continued )

### Current Sense

PARAMETER	SYMBOL	TEST CONDITIONS	MIN	TYP	MAX	UNIT
Gain	$G_v$	(Note 1&2)	2.85	3.0	3.15	V/V
Maximum Input Singal	$V_{I(MAX)}$	$V_{COMP}=5V$ (Note1)	0.9	1.0	1.1	V
Supply Voltage Rejection	SVR	$12 \leq V_{CC} \leq 25V$ (Note1)		70		dB
Input bias current	$V_{BIAS}$	$V_{sense}=3V$		-2	-10	$\mu A$
Delay to Output	$t_{DO}$			150	300	ns

### Output

PARAMETER	SYMBOL	TEST CONDITIONS	MIN	TYP	MAX	UNIT
$V_{OUT}$ Low Voltage	$V_{OL}$	$I_{SINK} = 20mA$		0.08	0.4	V
		$I_{SINK} = 200mA$		1.2	2.0	
$V_{OUT}$ High Voltage	$V_{OH}$	$I_{SOURCE} = 20mA$	13	13.5		V
		$I_{SOURCE} = 200mA$	12	13.0		
Rise Time	$T_j=25$ , $C_L=1nF$ (Note 3)			45	150	Ns
Fall Time	$T_j=25$ , $C_L=1nF$ (Note 3)			35	150	ns

†All typical values are at  $T_A = 25$  .

### Total device

PARAMETER	SYMBOL	TEST CONDITIONS	MIN	TYP	MAX	UNIT
Start-up Current	$I_{ST}$			0.05	0.07	mA
Operating supply current	$I_{CC(OPR)}$	$V_{FB}=0V, V_{SENSE}=0V$	10	13	15	mA
$V_{CC}$ Zener Voltage	$V_z$	$I_{CC}=25mA$	30	38		V

†All typical values are at  $T_A = 25$  .

- Notes
- 1.Parameter measured at trip point of latch with  $V_{FB}=0V$ .
  - 2.Gain defined as  $A= V_{COMP}/ V_{SENSE}; 0 \leq V_{SENSE} \leq 0.8V$ .
  - 3.These parameters, although guaranteed, are not 100% tested in production.



## Detailed Description

This is a simple application circuit for 35W Adaptor example. The gate of MOSFET is connected to pin6 of HY5002, and PWM duty is determined by EA feedback signal from the photo coupler and R3 sense voltage.

The initial start-up voltage of HY5002 comes from AC line and through R6, and normal supply voltage is available until the T1 transformer converted the store energy to T1 primary side output through D3 and R19 to HY5002.

The  $V_{REF}$  voltage of KA431A with R13 and R14 determine the output voltage of  $V_{OUT}$ .

SCR and ZD1 is a very simple circuit for  $V_{OUT}$  over-voltage protection.

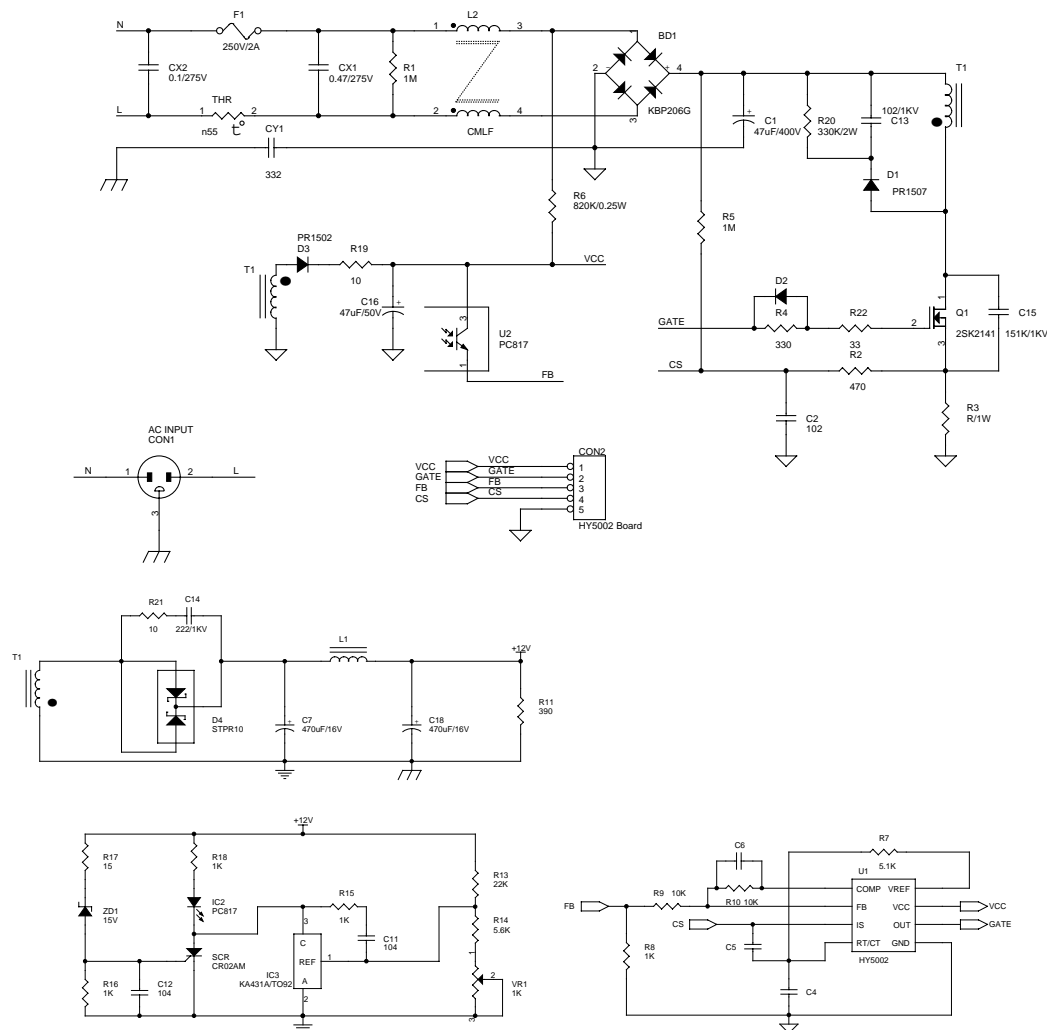





## Package outline

### SOP 8

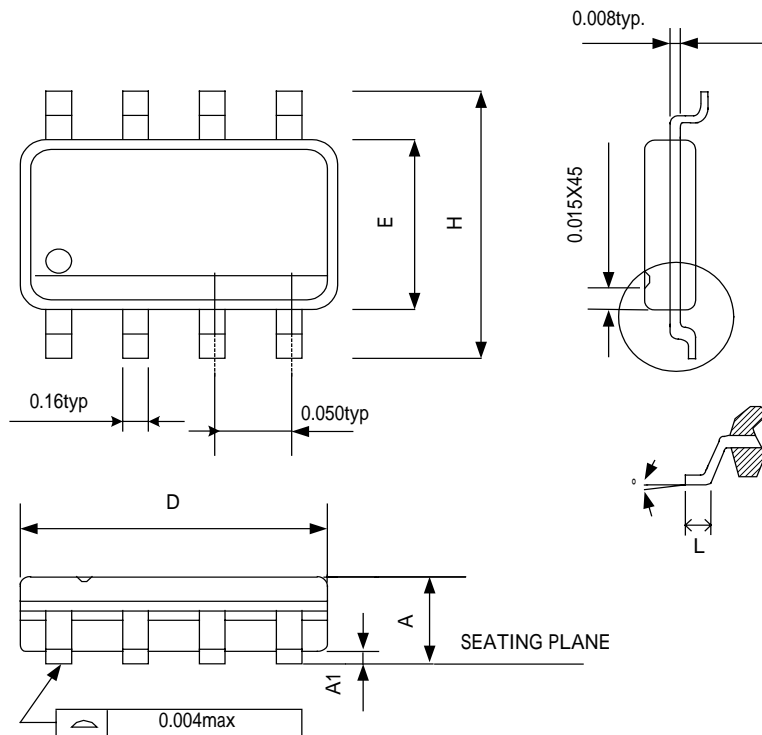

**NOTE:**

1. JEDEC OUTLINE: MS-012 AA

1. DIMENSIONS "D" DOES NOT INCLUDE MOLD FLASH, PROTRUSIONS OR GATE BURRS. MOLD FLASH, PROTRUSIONS AND GATE BURRS SHALL NOT EXCEED .15mm (.006in) PER SIDE

2. DIMENSIONS "E" DOES NOT INCLUDE INTER-LEAD FLASH, OR PROTRUSIONS. INTER-LEAD FLASH AND PROTRUSIONS SHALL NOT EXCEED .25mm (.010in) PER SIDE.

SYMBOLS	MIN	MAX
A	0.053	0.069
A1	0.004	0.010
D	0.189	0.196
E	0.150	0.157
H	0.228	0.244
L	0.016	0.050
$^\circ$	0	8



## PDIP 8

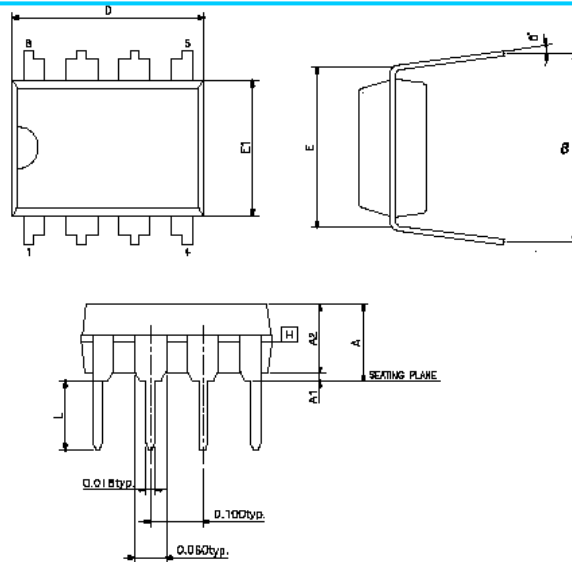

SYMBOLS	MIN	NOR	MAX
A	-	-	0.210
A1	0.015	-	-
A2	0.125	0.130	0.135
D	0.355	0.365	0.400
E	0.300BSC		
E1	0.245	0.250	0.255
L	0.115	0.130	0.150
e	0.335	0.355	0.375
°	0	7	15

Note:

0. JEDEC OUTLINE:MS-001 BA

1. "D" "E1" DIMENSIONS DO NOT INCLUDE MOLD FLASH OR PROTRUSIONS SHALL NOT EXCEED .010 INCH
2. eB IS MEASURED AT THE LEAD TIPS WITH THE LEADS UNCONSTRAINED
3. POINTED OR ROUNDED LEAD TIPS ARE PREFERRED TO EASE INSERTION
4. DISTANCE BETWEEN LEADS INCLUDING DAM BAR PROTRUSIONS TO BE .005 INCH MINIMUM
5. DATUM PLANE H COINCIDENT WITH THE BOTTOM OF LEAD, WHERE LEAD EXITS BODY.



### Packing Specifications Box

TUBE INSIDE BOX AND CARTON

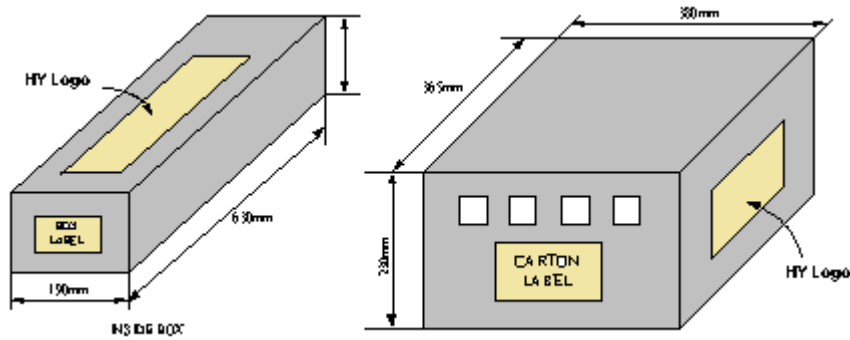

TAPE & REEL INSIDE BOX AND CARTON

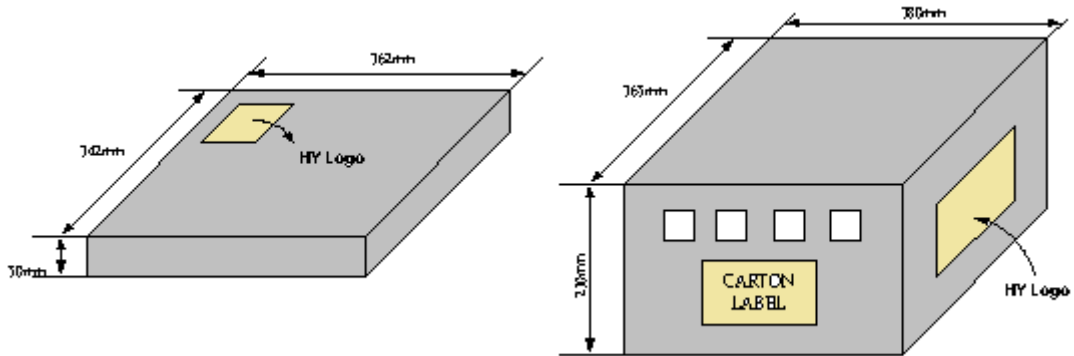

### Packing Quantity Specifications

100 EA / TUBE	2500 EA / REEL
100 TUBES / INSIDE BOX	4 INSIDE BOXES / CARTON
4 INSIDE BOXES / CARTON	

### Label Specifications

TAPPING & REEL

Feeling Technology Corp.	
Product	HY5002
Lot No	A3311C62
D/C	AxxxxL
Q'ty	
<b>無鉛</b> <b>Lead Free</b>	



CARTON

Feeling Technology Corp.  
 Product Type: HY5002  
 Lot No: A3311C62  
 Date Code: AxxxxL  
 Package Type: SOP-8L  
 Marking Type: Laser  
 Total Q'ty: 10,000

無鉛  
Lead Free

### Carrier Tape Dimensions

APPLICATION	W	P	E	F	D	D <sub>1</sub>
SOP8	12.0 <sup>+0.3</sup> <sub>-0.1</sub>	8.0±0.1	1.75±0.1	5.5±0.1	1.55±0.1	1.5 <sup>+0.25</sup>

APPLICATION	P <sub>0</sub>	P <sub>1</sub>	A <sub>0</sub>	B <sub>0</sub>	K <sub>0</sub>	t
SOP8	4.0±0.1	2.0±0.1	6.4±0.1	5.20±0.1	2.1±0.10	0.30±0.013

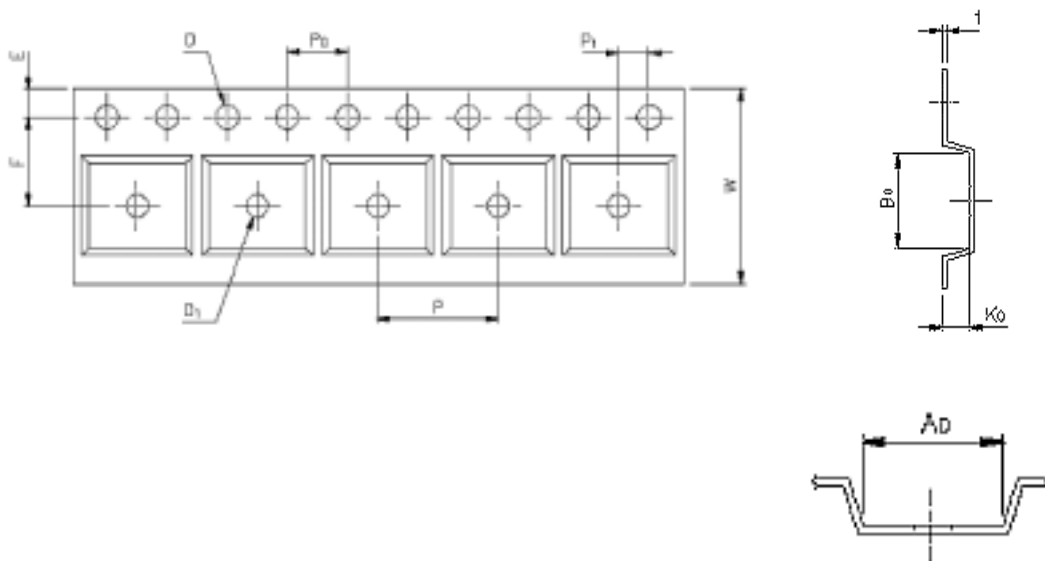



## C over Tape Dimensions

CARRIER WIDTH	12	16	24
COVER TAPE WIDTH	9.3	13.3	21.3

(mm)

## Reel Dimensions

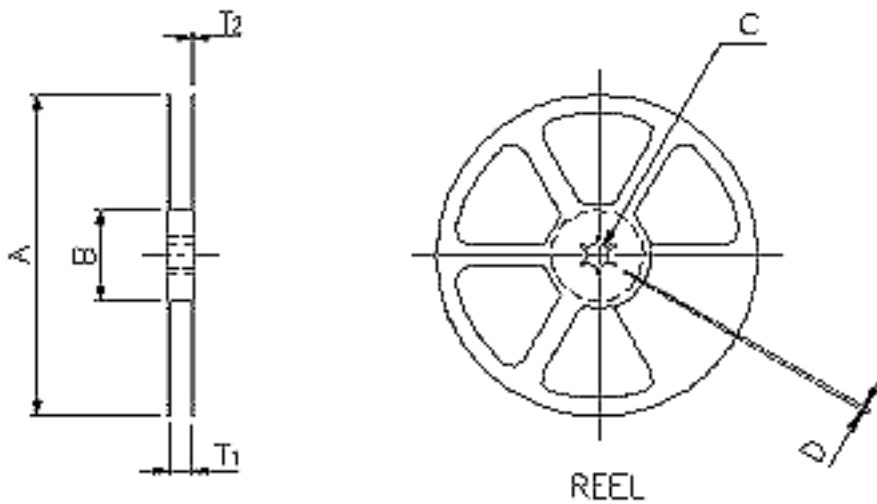

APPLICATION	MATERIAL	A	B	C	D	T <sub>1</sub>	T <sub>2</sub>
SOP8	PLASTIC REEL (WHILE)	330±0.1	62±1.5	12.75+0.1 5	2+0.6	12.4+0.2	2.0+0.2