

# **ILLUMINANT** 北極光企業有限公司

## PRODUCT SPECIFICATION FOR TFT LCM

<b>CUSTOMER:</b>	
<b>MODEL NO:</b>	I 1813-6I PN1216A
<b>ACCEPTED BY:</b>	

<b>APPROVED BY:</b>	<b>CHECKED BY:</b>	<b>ORGANIZED BY:</b>
		

- Approval for Specifications Only**  
 **Approval for Specifications and Sample**

- Note: 1. Version of Specifications : 1**  
**2. Others: Rohs Compliment**

**TAIWAN**

1F, #15, LANE 75, MIN CHUAN E. RD., SEC 3, TAIPEI, TAIWAN.

Tel +886-2-25175115 Fax +886-2-25175099

**CHINA**

5F DONGWU COMMERICAL BLDG., LANSHAN RD., NORTH DISTRICT, HI-TECH INDUSTRIAL PARK, SHENZHEN, PRC.

TEL + 86-755-86154466 FAX +86-755-86154366

**KOREA**

RM 1201, IT MIRAE TOWER, 60-21, GASAN-DONG, GEUMCHEON-GU, SEOUL, 153-801, KOREA

TEL + 82-2-2027-5391~2 FAX +82-2-2027-5393



## **CONTENTS**

- 1. Mechanical Specification**
- 2. Absolute Maximum Ratings**
- 3. Electrical Characteristics**
- 4. Optical Characteristics**
- 5. Interface**
- 6. Block Diagram**
- 7. Timing Characteristics**
- 8. Backlight**

## 1. Mechanical Specification

Item	Standard Value	Unit
Display Size	1.77	inch
Module Dimension	34.0(W)×47.0(H)×2.4(D)	mm
Active Area	28.032 (W)×35.04(H)	mm
Number of Dots	128 × RGB × 160	Dot
Pixel Pitch	0.219(W)×0.219(H)	mm
LCD Type	Normal White	-
Viewing Direction	6H	-
Driver	ILI9163B	-
Approx. Weight	TBD	g
Various Color Display	262	K
Backlight Type	2-LED parallel (White)	
Brightness	220	cd/m <sup>2</sup>

引脚号	名称
1	GND
2	NC
3	NC
4	/RESET
5	DB15
6	DB14
7	DB13
8	DB12
9	DB11
10	DB10
11	DB9
12	DB8
13	DB7
14	DB6
15	DB5
16	DB4
17	DB3
18	DB2
19	DB1
20	DB0
21	/RD
22	/WR
23	RS
24	CS
25	VDD
26	GND
27	LED-
28	LED+
29	LED+

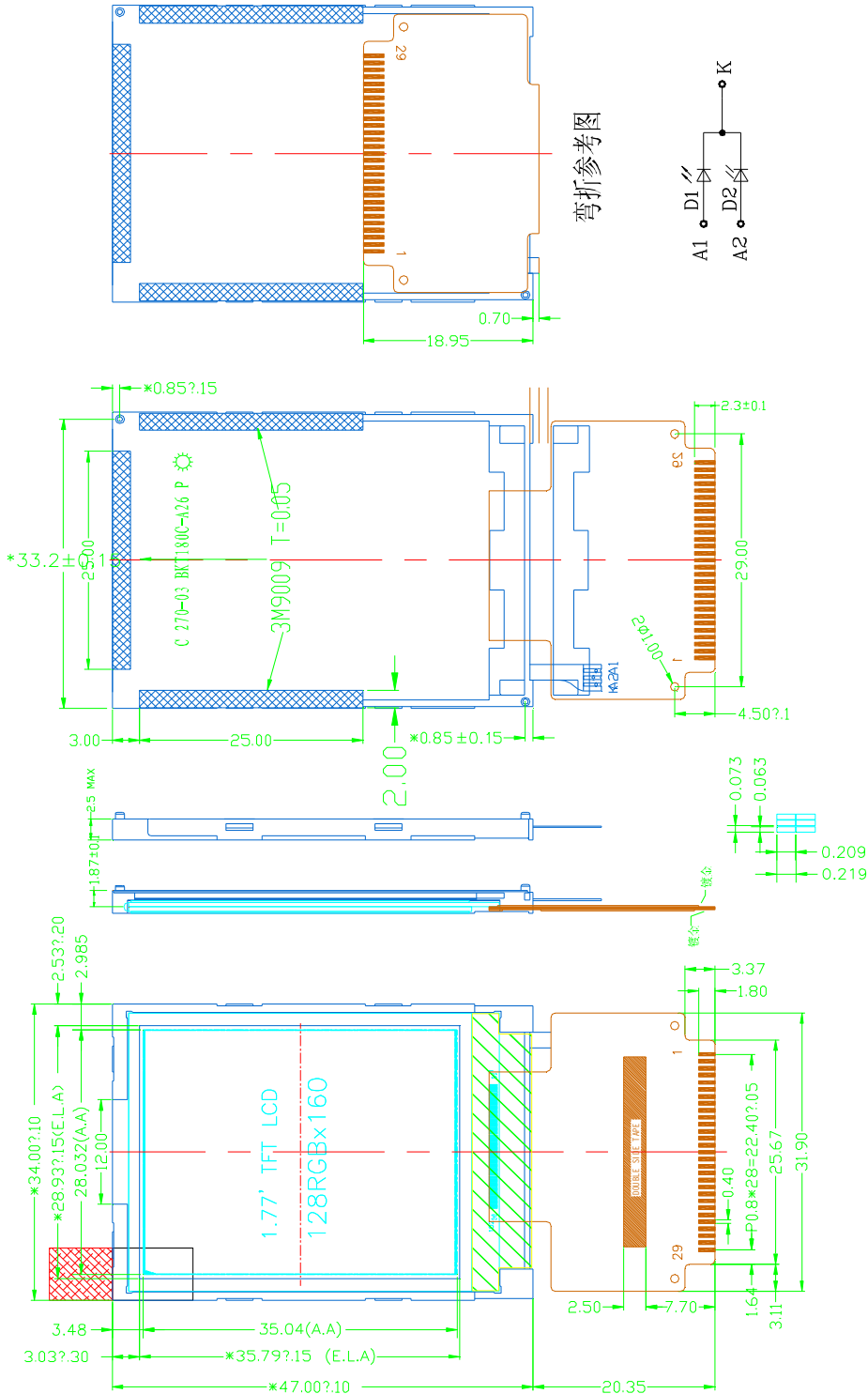

弯折参考图

REVISED RECORD		NOTE: I1I9163B	
A	B	C	D
		5. OPERATIVE VOLTAGE	3.0v
		6. OPERATIVE TEMP	-20° C-70° C
		7. STORAGE TEMP	-30° C-80° C
		8. CONNECTOR	TCP

北极光企业有限公司(ILLUMINANT CO., LTD)

Drawn	Page: 1 of 4	Unit: mm	Date: 2009-11-30
Check	Rev: 1.0	Scale: 1/1	Projection:
Approve	Dwn.No 11813-6IPN1216A		

## 2. Absolute Maximum Ratings

Item	Symbol	Min.	Typ.	Max.	Unit	Remark
Supply Voltage for Logic	V <sub>DD</sub>	-0.3		+4.6	V	
Input Voltage	V <sub>in</sub>	-0.5		V <sub>DD</sub> +0.3	V	
Driver Supply Voltage	V <sub>GH-VGL</sub>	V <sub>DD</sub> =3V	--	15	--	-
Operating Temperature	T <sub>OP</sub>	-20	-	+70	°C	-
Storage Temperature	T <sub>ST</sub>	-30	-	+80	°C	-

\*NOTE: Based on V<sub>SS</sub>=0V.

## 3. Electrical Characteristics

Item	Symbol	Condition	Min.	Typ.	Max.	Unit
Supply Voltage for Logic	V <sub>DD</sub>	T <sub>a</sub> =25°C	2.6	3.0	3.3	V
High-Level Input Voltage	V <sub>IHC</sub>	V <sub>DD</sub> =3V	0.7V <sub>DD</sub>		V <sub>DD</sub>	
Low-Level Input Voltage	V <sub>ILC</sub>	V <sub>DD</sub> =3V	-0.3		0.3V <sub>DD</sub>	
Power Supply Current for V <sub>DD</sub>	I <sub>DD</sub>	V <sub>DD</sub> =3V	-	8.5		mA

# ILLUMINANT

## 4. Optical Characteristics

Item	Symbol	Conditions	Specifications			Unit	Note	
			Min.	Typ.	Max.			
Transmittance	T%	Viewing normal angle $\theta$ x- $\theta$ y-0		6.5		%		
Contrast Ratio	CR		150	250	-	-		
Response Time	T <sub>R</sub>		-	10	20	ms		
	T <sub>F</sub>		-	20	30	ms		
Chromaticity	Red		X <sub>R</sub>	0.611	0.641	0.671		
			Y <sub>R</sub>	0.315	0.345	0.375		
	Green		X <sub>G</sub>	0.266	0.296	0.326		
			Y <sub>G</sub>	0.554	0.584	0.614		
	Blue		X <sub>B</sub>	0.102	0.132	0.162		
			Y <sub>B</sub>	0.106	0.136	0.166		
	White	X <sub>W</sub>	0.279	0.309	0.339			
		Y <sub>W</sub>	0.318	0.348	0.378			
Viewing Angle	Hor.	$\theta$ x+	-	45		Deg.		
		$\theta$ x-	-	45				
	Ver.	$\theta$ y+	-	15				
		$\theta$ y-	-	35				

### NOTE 1: Optical Characteristic Measurement System

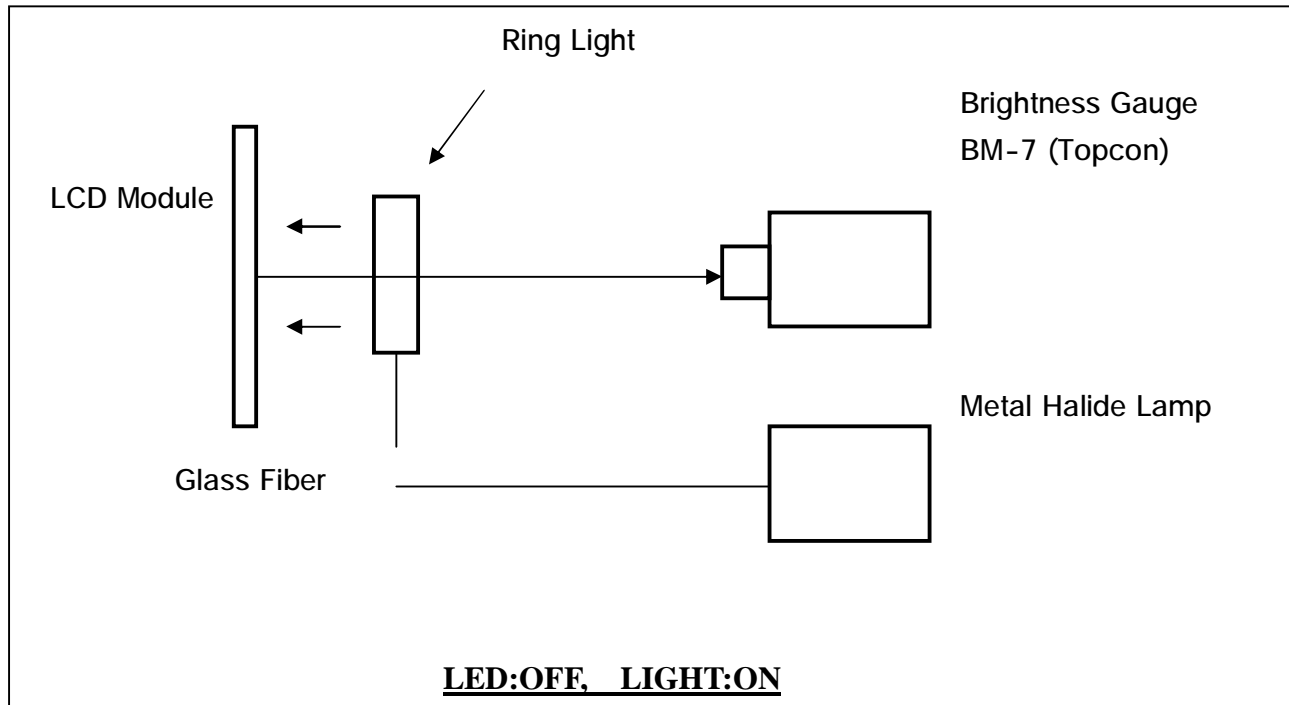

# ILLUMINANT

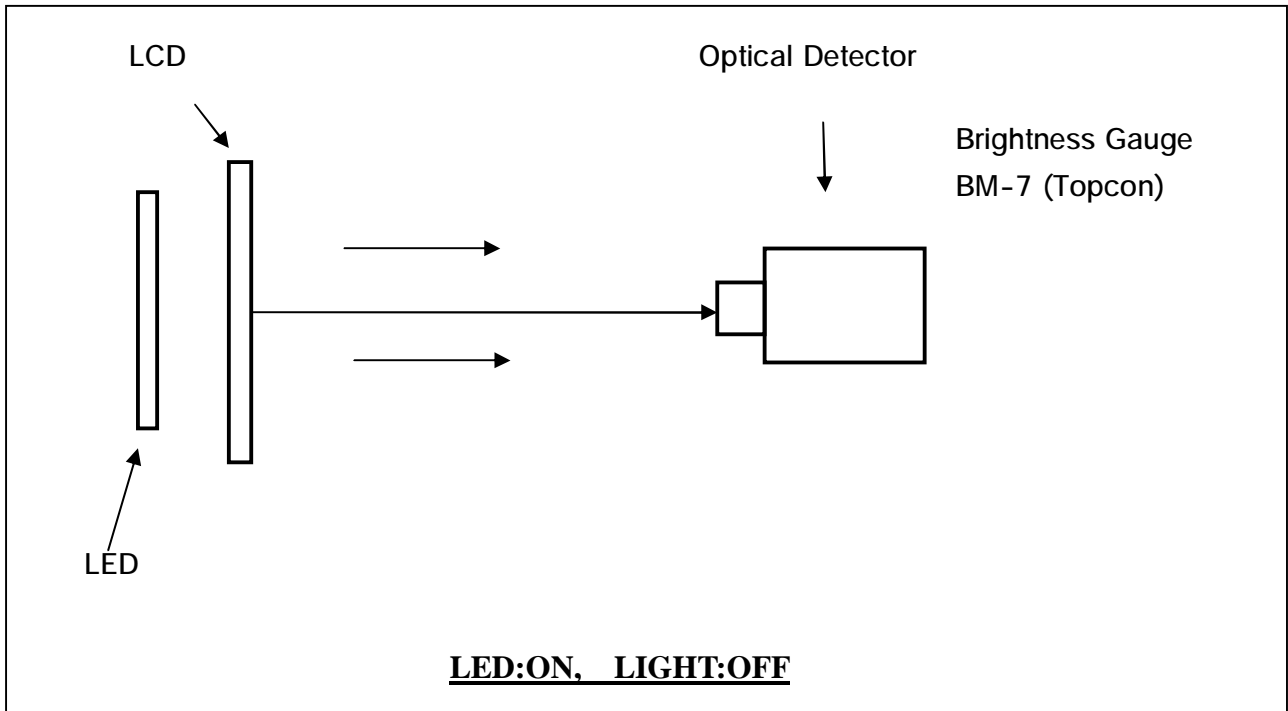

## NOTE 2: Response Time Definition

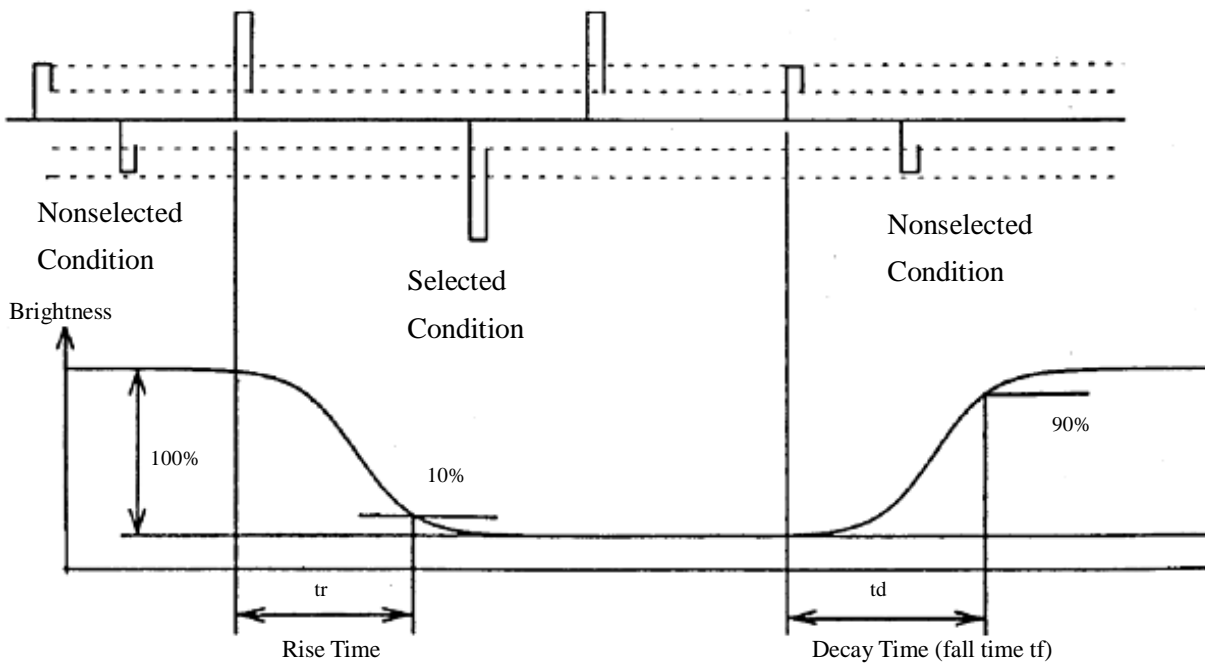



# ILLUMINANT

## NOTE 3: $\phi \cdot \theta$ Definition

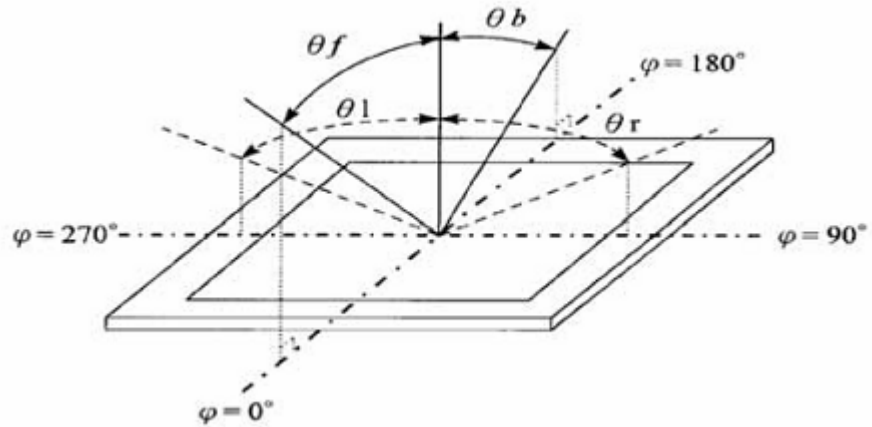

## NOTE 4: Contrast Definition

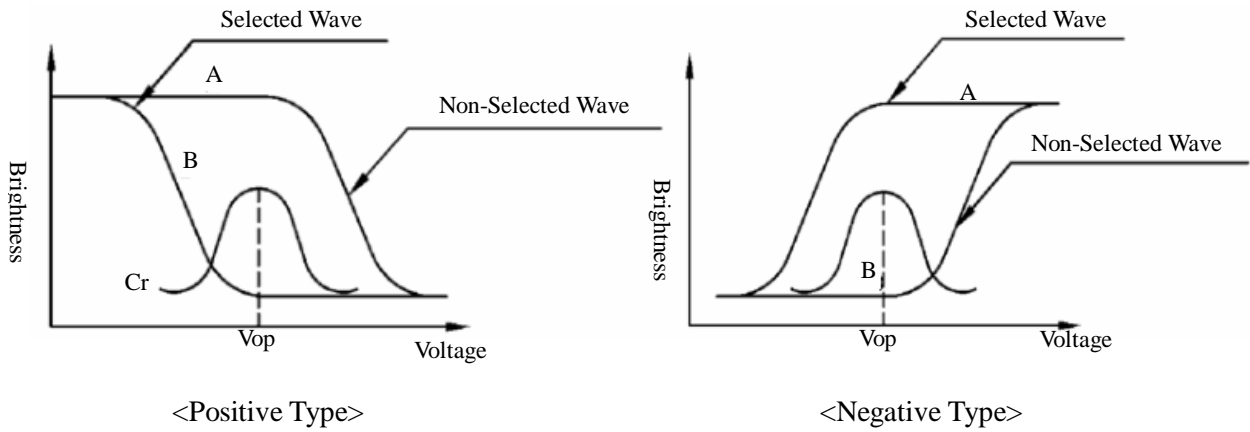

## NOTE 5: Visual Angle Direction Priority

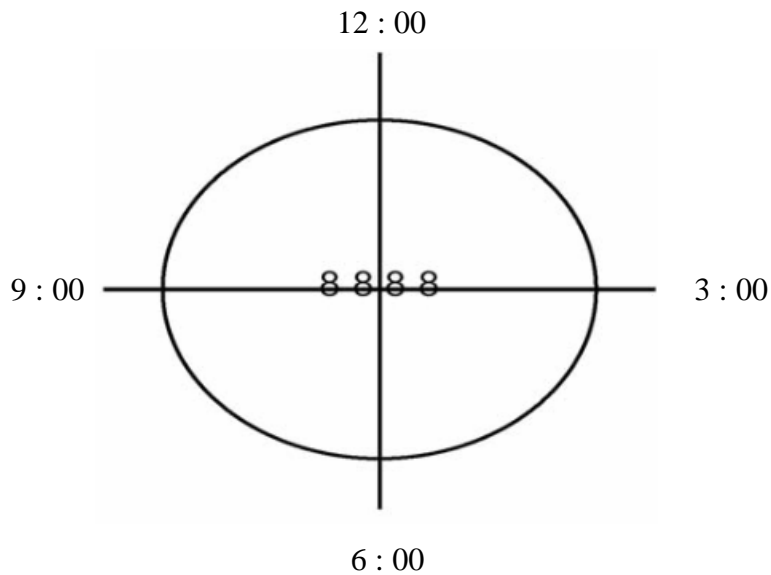

## 5. Interface

Pin No.	Symbol	Function
1	GND	Ground
2	NC	No Connection
3	NC	No Connection
4	/RESET	Reset Signal
5	DB15	It should Connect to GND on customer board
6	DB14	It should Connect to GND on customer board
7	DB13	It should Connect to GND on customer board
8	DB12	It should Connect to GND on customer board
9	DB11	It should Connect to GND on customer board
10	DB10	It should Connect to GND on customer board
11	DB9	It should Connect to GND on customer board
12	DB8	It should Connect to GND on customer board
13	DB7	Data Bus
14	DB6	Data Bus
15	DB5	Data Bus
16	DB4	Data Bus
17	DB3	Data Bus
18	DB2	Data Bus
19	DB1	Data Bus
20	DB0	Data Bus
21	/RD	Read Execute Control Signal
22	/WR	Write Execute Control Signal
23	RS	Command/Data Select Pin
24	CS	Chip Select Pin
25	VDD	Power Supply
26	GND	Ground
27	LED-	LED cathode
28	LED1+	LED anode
29	LED2+	LED anode

## 6. Block Diagram

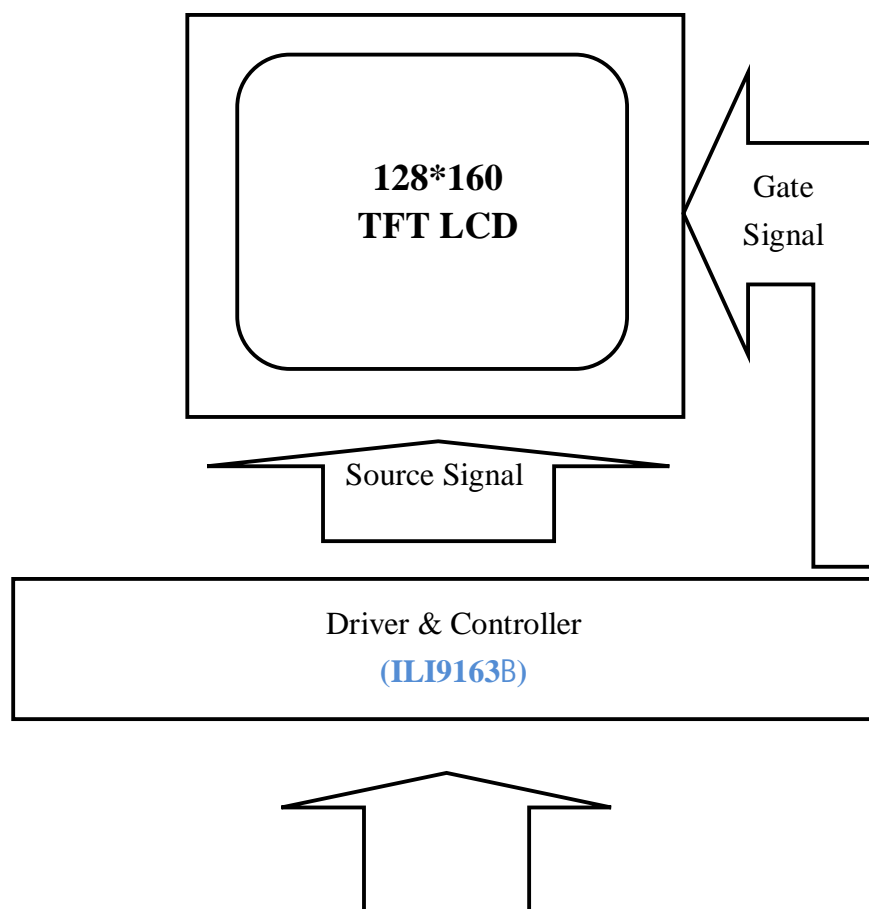

## 7. Timing Control

Normal Write Mode (IOVCC=1.65~3.3V, VCC=2.4~3.3V)

Item		Symbol	Unit	Min.	Typ.	Max.	Test Condition
Bus cycle time	Write	$t_{CYCW}$	ns	100	-	-	-
	Read	$t_{CYCR}$	ns	300	-	-	-
Write low-level pulse width		$PW_{LW}$	ns	50	-	-	-
Write high-level pulse width		$PW_{HW}$	ns	50	-	-	-
Read low-level pulse width		$PW_{LR}$	ns	150	-	-	-
Read high-level pulse width		$PW_{HR}$	ns	150	-	-	-
Write / Read rise / Fall time		$t_{WRr}/t_{WRf}$	ns	-	-	25	
Setup time	Write (RS to nCS, E/nWR)	$t_{AS}$	ns	10	-	-	
	Read (RS to nCS, RW/nRD)			5	-	-	
Address hold time		$t_{AH}$	ns	5		-	
Write data set up time		$t_{DSW}$	ns	10		-	
Write data hold time		$t_H$	ns	15		-	
Read data delay time		$t_{DDR}$	ns	-		100	
Read data hold time		$t_{DHR}$	ns	5		-	

### i80 18/16-bit System Bus Interface Timing

#### (a) Write to Register

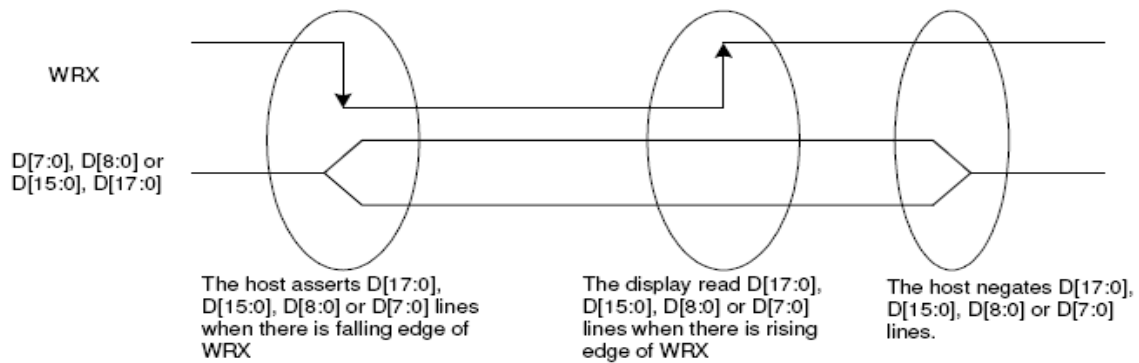

#### (b) Read from Register

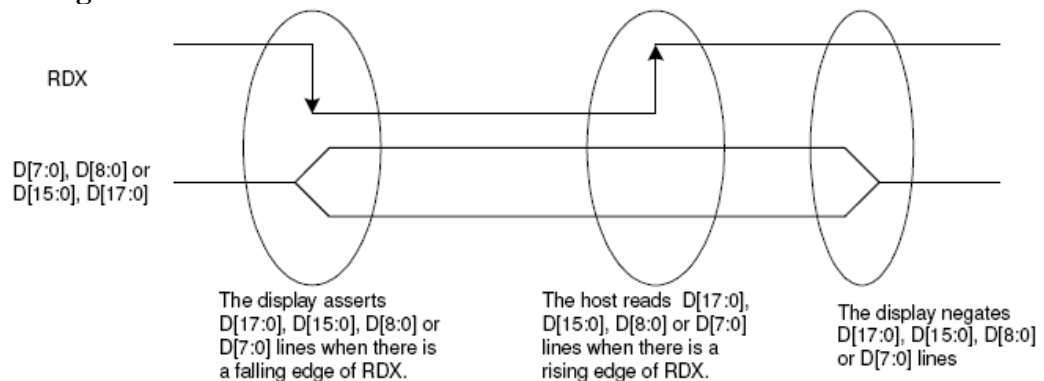

# ILLUMINANT

## 8. Backlight

### 8.1 Standard Lamp Styles (Edge Lighting Type):

The LED chips are distributed over the edge light area of the illumination unit, which gives the less power consumption:

### 8.2 The Main Advantages of the LED Backlight are as Following:

The brightness of the backlight can simply be adjusted. By a resistor or a potentiometer.

### 8.3 Data About LED Backlight:

Item	Symbol	Conditions	Min.	Typ.	Max.	Unit
Forward voltage	Vf	If =40	-	3.2	3.5	V
Forward current	If		-	40		mA
Uniformity	-	If=40	80%	-	-	-
B/L luminance		If=40	3200	3700	4800	cd/m2
Luminous color	-	White				
Chip connection	-	2-LED parallel connection				

NOTE:

- 1.Backlight Only
- 2.Average Luminous Intensity of P1-P9
- 3.Uniformity =  $\text{Min}(P1 \sim P9) / \text{Max}(P1 \sim P9) * 100\% > 80\%$

### 8.4 Measured Method:

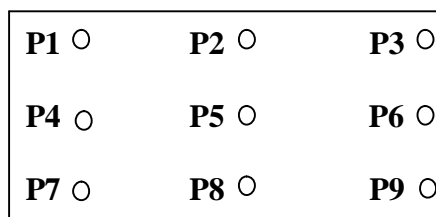

(Effective spatial Distribution)

Hole Diameter  $\pm 1\phi$  ; 1 to 9 per Position Measured Luminous