

# **ILLUMINANT** 北極光企業有限公司

## PRODUCT SPECIFICATION FOR LCM

<b>CUSTOMER:</b>	
<b>MODEL NO:</b>	<b>I2003-6IPN1722A</b>
<b>ACCEPTED BY:</b>	

<b>APPROVED BY:</b>	<b>CHECKED BY:</b>	<b>ORGANIZED BY:</b>
		

- Approval for Specifications Only**  
 **Approval for Specifications and Sample**

- Note: 1. Version of Specifications : 1**  
**2. Others: Rohs Compliment**

### TAIWAN

1F, #15, LANE 75, MIN CHUAN E. RD., SEC 3, TAIPEI, TAIWAN.

Tel +886-2-25175115 Fax +886-2-25175099

### CHINA

5F DONGWU COMMERCIAL BLDG., LANSHAN RD., NORTH DISTRICT, HI-TECH INDUSTRIAL PARK, SHENZHEN, PRC.

TEL + 86-755-86154466 FAX +86-755-86154366

### KOREA

RM 1201, IT MIRAE TOWER, 60-21, GASAN-DONG, GEUMCHEON-GU, SEOUL, 153-801, KOREA

TEL + 82-2-2027-5391~2 FAX +82-2-2027-5393



## **CONTENTS**

- 1. Mechanical Specification**
- 2. Absolute Maximum Ratings**
- 3. Electrical Characteristics**
- 4. Optical Characteristics**
- 5. Interface**
- 6. Block Diagram**
- 7. Timing Characteristics**
- 8. Backlight**
- 9. Reliability**

# ILLUMINANT

## 1. Mechanical Specification

Item	Standard Value	Unit
Display Size	2.0	inch
Module Dimension	37.68(W)*51.3(H)*2.15(T)	mm
Active Area	31.68(W)*39.6(H)	mm
Number of Dots	176RGB*220Dots	Dot
Pixel Pitch	0.18(W)mm*0.18(H)mm	mm
LCD Type	Normal White	-
Viewing Direction	6H	-
Driver	ILI9225B	-
Approx. Weight	TBD	g
Various Color Display	262K	
Backlight Type	3-LED parallel	
Backlight Color	White	

PIN	Define
1	DB15
2	DB14
3	DB13
4	DB12
5	DB11
6	DB10
7	DB9
8	DB8
9	GND
10	DB7
11	DB6
12	DB5
13	DB4
14	DB3
15	DB2
16	DB1
17	DB0
18	IOVCC
19	VCC
20	/RD
21	/WR
22	RS
23	/CS
24	RESET
25	IM0
26	GND
27	LED_A
28	LED_K1
29	LED_K2
30	LED_K3
31	NC
32	NC
33	NC
34	NC
35	NC
36	NC

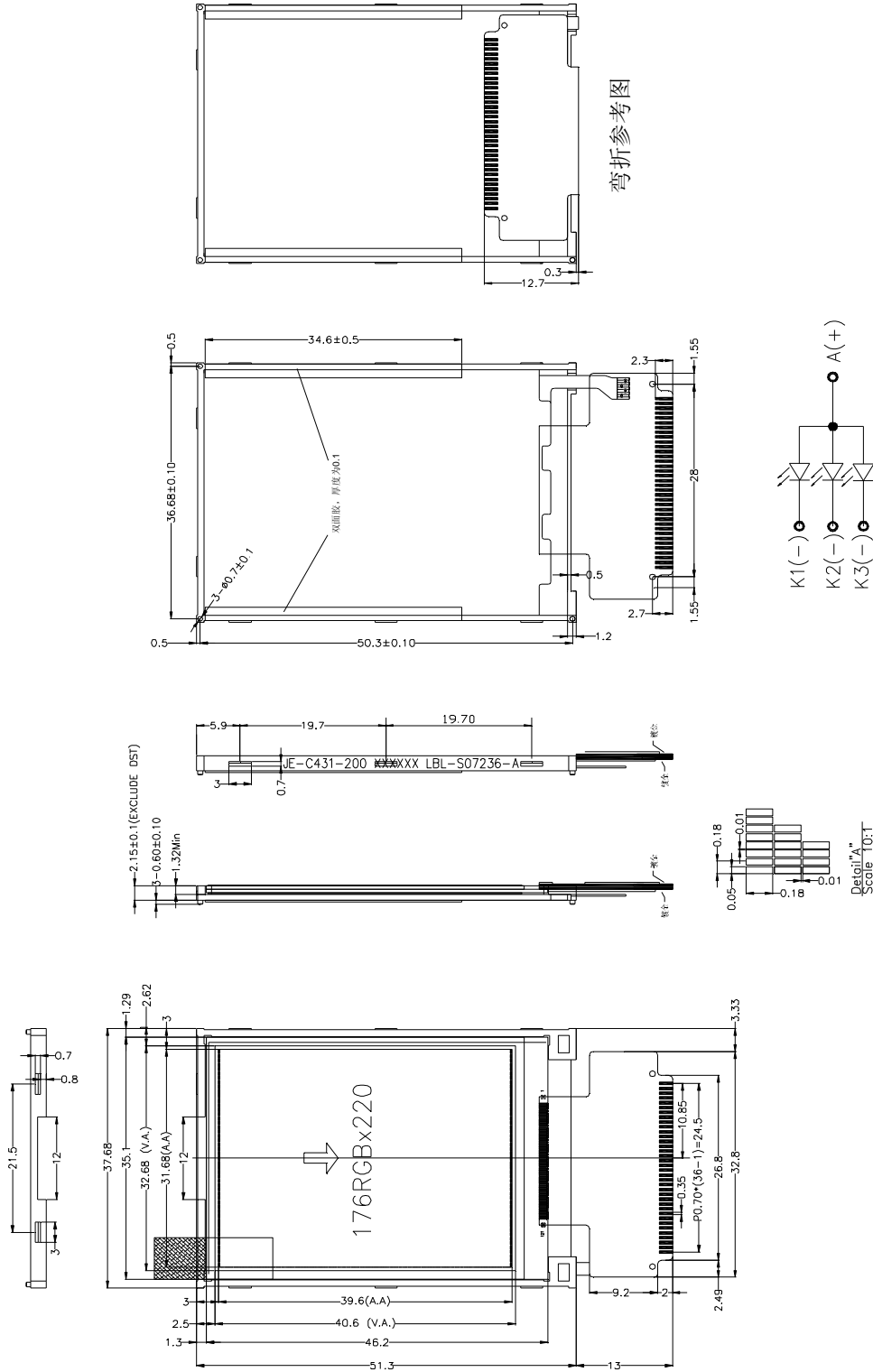

弯折参考图

北极光企业有限公司  
ILLUMINANT CO., LTD

Drawn	Tel: 0755-86154466	Fax: 0755-86154366
Check	Page: 1 of 5	Unit: mm
Approve	Rev: 1.0	Scale: 1/1
Down.No	I2003-6IPN1722A	
Date:	2010-1-05	
Projection:		

REVISED RECORD	
A	B
3.0v	5. OPERATIVE VOLTAGE
-20° C - 70° C	6. OPERATIVE TEMP
-30° C - 80° C	7. STORAGE TEMP
TCP	8. CONNECTOR

NOTE: I119225B

1. DISPLAY TYPE 262K TFT/POSITIVE
2. VIEWING DIRECTION 12 O' CLOCK
3. POLARIZER MODE TRANSMISSIVE
4. BACKLIGHT TAPE WHITE LED

## 2. Absolute Maximum Ratings

Item	Symbol	Min.	Typ.	Max.	Unit	Remark
Supply Voltage for Logic	V <sub>DD</sub>	-0.3		+4.0	V	
Input Voltage	V <sub>in</sub>	-0.5		V <sub>DD</sub> +0.5	V	
Operating Temperature	T <sub>OP</sub>	-20	-	+70	°C	-
Storage Temperature	T <sub>ST</sub>	-30	-	+80	°C	-

\*NOTE: Based on V<sub>SS</sub>=0V.

## 3. Electrical Characteristics

Item	Symbol	Condition	Min.	Typ.	Max.	Unit
Supply Voltage for Logic	V <sub>DD</sub>	T <sub>a</sub> =25°C	2.2	2.8	3.3	V
High-Level Input Voltage	V <sub>IHC</sub>	V <sub>DD</sub> =3.0V	0.8V <sub>DD</sub>		V <sub>DD</sub>	
Low-Level Input Voltage	V <sub>ILC</sub>	V <sub>DD</sub> =3.0V	-0.3		0.2V <sub>DD</sub>	
TFT Gate ON Voltage	V <sub>GH</sub>	V <sub>DD</sub> =3.0V	--	15	--	-
TFT Gate OFF Voltage	V <sub>GL</sub>	V <sub>DD</sub> =3.0V	--	-8	--	V
Power Supply Current for V <sub>DD</sub>	I <sub>DD</sub>	V <sub>DD</sub> =3.0V	-	8.5		mA

# ILLUMINANT

## 4. Optical Characteristics

Item	Symbol	Condition	Min.	Typ.	Max.	Unit	Note	
Contrast Ratio	CR	$\theta = 0^\circ, \phi = 0^\circ$	-	250	-	-	-	
Transmittance	T	-	-	13.04	-	%	-	
Color Chromaticity (CIE 1931)	Red	Rx	Normal viewing angle	0.605	0.625	0.645	-	(1)
		Ry		0.305	0.325	0.345	-	
	Green	Gx		0.272	0.292	0.312	-	
		Gy		0.555	0.575	0.595	-	
	Blue	Bx		0.113	0.133	0.153	-	
		By		0.114	0.134	0.154	-	
	White	Wx		0.285	0.305	0.325	-	
		Wy		0.310	0.330	0.350	-	

# ILLUMINANT

Notes :

1. Contrast Ratio(CR) is defined mathematically as :

$$\text{Contrast Ratio} = \frac{\text{Surface Luminance with all white pixels}}{\text{Surface Luminance with all black pixels}}$$

2. Surface luminance is the center point across the LCD surface 500mm from the surface with all pixels displaying white. For more information see FIG 1.

3. Response time is the time required for the display to transition from to black(Rise Time, TrR) and from black to white(Decay Time, TrD). For additional information see FIG 3.

4. Viewing angle is the angle at which the contrast ratio is greater than 10. The angles are determined for the horizontal or x axis and the vertical or y axis with respect to the z axis which is normal to the LCD surface. For more information see FIG 4.

5. Optimum contrast is obtained by adjusting the LCD Threshold voltage(Vth & Vsat)

**FIG. 1 Optical Characteristic Measurement Equipment and Method**

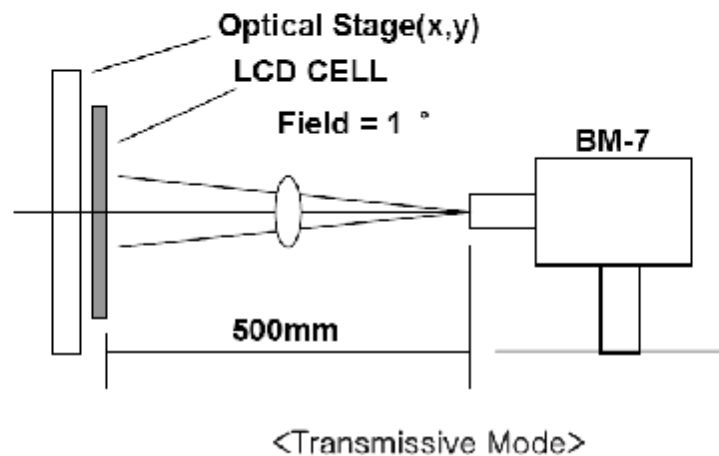



# ILLUMINANT

**FIG. 2 The definition of  $V_{th}$  and  $V_{sat}$**

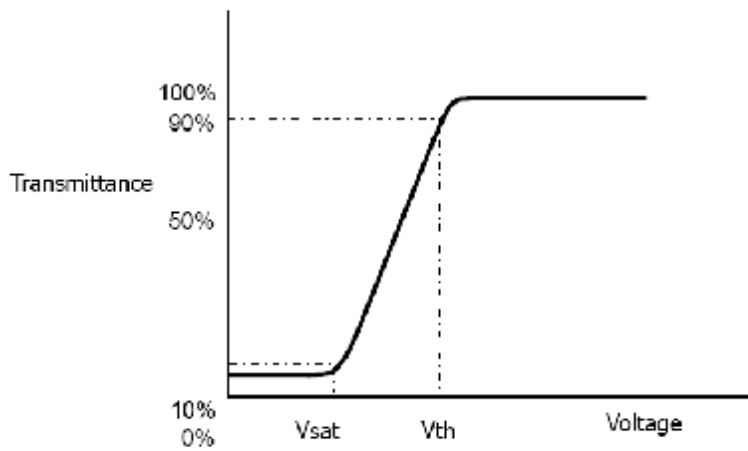

**FIG. 3 The definition of Response Time**

The response time is defined as the following figure and shall be measured by switching the input signal for “black” and “white”.

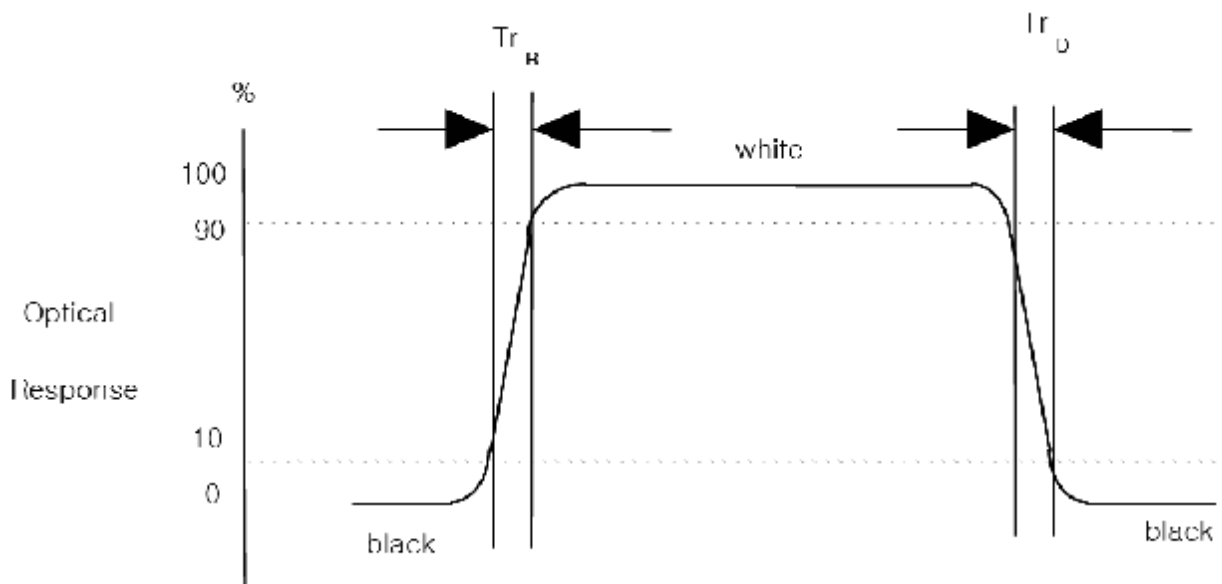

## 5. Interface

No.	Symbol	Function
1	D15	Data Bus
2	D14	Data Bus
3	D13	Data Bus
4	D12	Data Bus
5	D11	Data Bus
6	D10	Data Bus
7	D9	Data Bus
8	D8	Data Bus
9	GND	Ground
10	D7	Data Bus
11	D6	Data Bus
12	D5	Data Bus
13	D4	Data Bus
14	D3	Data Bus
15	D2	Data Bus
16	D1	Data Bus
17	D0	Data Bus
18	IOVCC	Power Supply
19	VCC	Power Supply
20	/RD	Read Signal
21	/WR	Write Signal
22	RS	Data/Command Select
23	/CS	Chip Select Signal
24	RESET	System Reset Pin
25	IM0	IM0=1 8bit or IM0=0 16bit
26	GND	Ground
27	LEDA	LED anode pin
28	LEDK1	LED cathode pin
29	LEDK2	LED cathode pin
30	LEDK3	LED cathode pin
31	NC	NC
32	NC	NC
33	NC	NC
34	NC	NC
35	NC	NC
36	NC	NC

## 6. Block Diagram

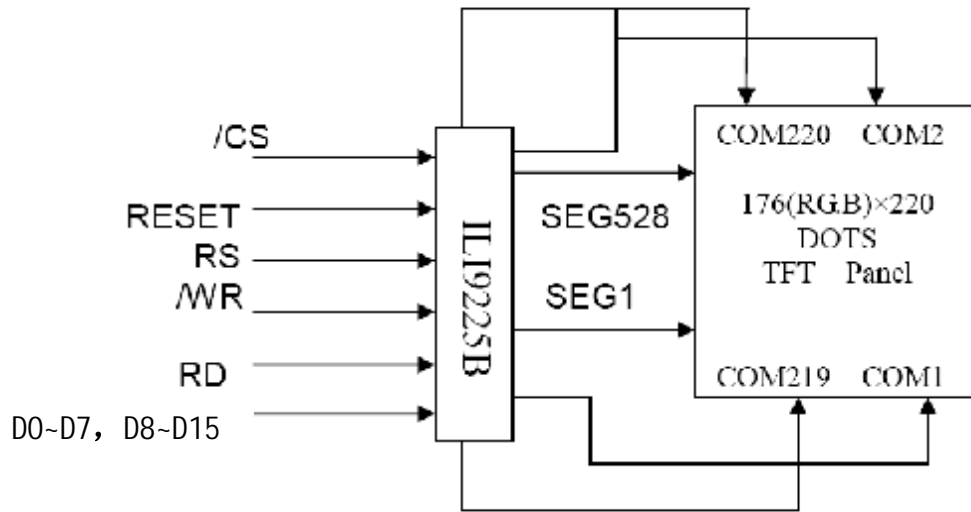

## 7. Timing Characteristics

### 7.1 Read/Write characteristics (8080-series MPU)

Write to the register

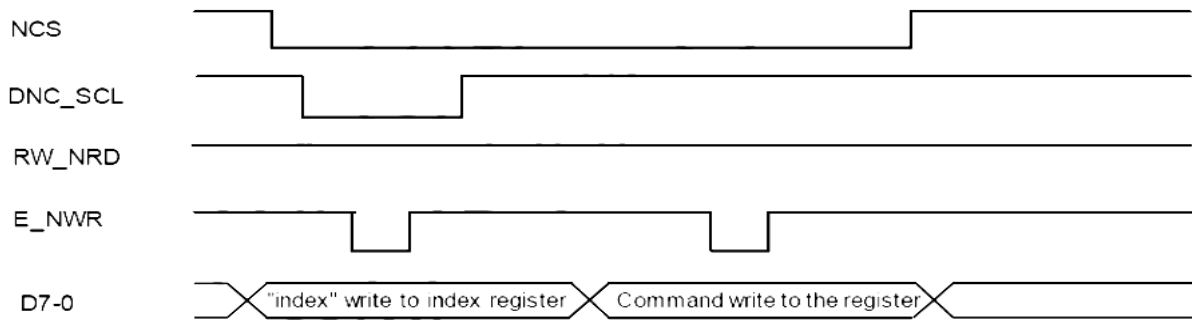

Read the register

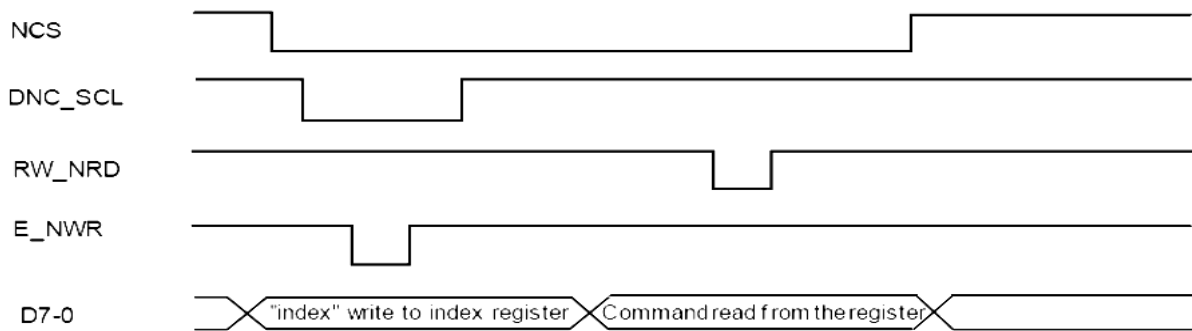

### Normal Write Mode (IOVCC=1.65~3.3V, VCC=2.4~3.3V)

Item	Symbol	Unit	Min.	Typ.	Max.	Test Condition
Bus cycle time	Write	$t_{CYCW}$	ns	100	-	-
	Read	$t_{CYCR}$	ns	300	-	-
Write low-level pulse width	$PW_{LW}$	ns	50	-	500	-
Write high-level pulse width	$PW_{HW}$	ns	50	-	-	-
Read low-level pulse width	$PW_{LR}$	ns	150	-	-	-
Read high-level pulse width	$PW_{HR}$	ns	150	-	-	-
Write / Read rise / Fall time	$t_{WR}/t_{WRF}$	ns	-	-	25	-
Setup time	Write (RS to nCS, E/nWR)	$t_{AS}$	ns	10	-	-
	Read (RS to nCS, RW/nRD)			5	-	-
Address hold time	$t_{AH}$	ns	5	-	-	-
Write data set up time	$t_{DSW}$	ns	10	-	-	-
Write data hold time	$t_H$	ns	15	-	-	-
Read data delay time	$t_{DDR}$	ns	-	-	100	-
Read data hold time	$t_{DHR}$	ns	5	-	-	-

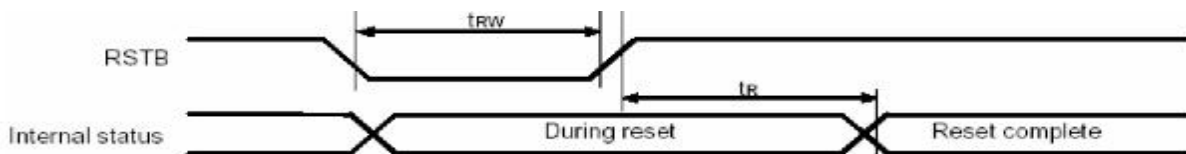

(VSS=0V, VDD3 = 1.8V, Ta = -30 to +70°C)

Item	Signal	Symbol	Condition	Min.	Max.	Unit
Reset low pulse width	RSTB	$Trw$		1000	-	ns
Reset time	-	$tr$		-	1000	ns

# ILLUMINANT

## 8. Backlight

### 8.1 Standard Lamp Styles (Edge Lighting Type):

The LED chips are distributed over the edge light area of the illumination unit, which gives the less power consumption:

### 8.2 The Main Advantages of the LED Backlight are as Following:

The brightness of the backlight can simply be adjusted. By a resistor or a potentiometer.

### 8.3 Data About LED Backlight:

Item	Symbol	Conditions	Min.	Typ.	Max.	Unit
Forward voltage	Vf	-	-	3.2	3.5	V
Forward current	If		54	-	-	mA
Uniformity	-	Vf =3.2V	80%	-	-	-
Luminous color	-	White				
Chip connection	-	3-LED parallel connection				

NOTE:

- 1.Backlight Only
- 2.Average Luminous Intensity of P1-P9
- 3.Uniformity =  $\text{Min}(P1\sim P9)/\text{Max}(P1\sim P9) * 100\% > 80\%$

### 8.4 Measured Method:

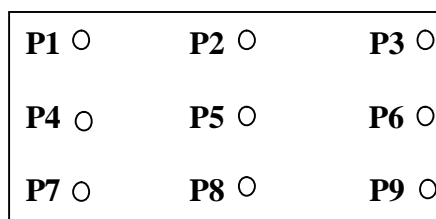

(Effective spatial Distribution)

Hole Diameter  $\pm 1\phi$  ; 1 to 9 per Position Measured Luminous

# ILLUMINANT

## 9. Reliability

### 9.1 MTTF

The LCD module shall be designed to meet a minimum MTTF value of 50,000 hours with normal condition. (25°C in the room without sunlight; not include lifetime of backlight and Touch Panel).

### 9.2 Tests

No.	Item	Condition	Criterion
1	High Temperature Operating	+70°C 240hrs	◦ No defect of operational function in room temperature are allowable(23±5°C). ◦ Leakage current should be below double of initial value.
2	Low Temperature Operating	-20°C 240hrs	
3	High Temperature Non-Operating	+80°C 240hrs	
4	Low Temperature Non-Operating	-30°C 240hrs	
5	High Temperature / Humidity Non-Operating	60°C ; 90% RH ; 240hrs	
6	Temperature Shock Operating	-20°C ↔ 70°C (30min) (5min) (30min) 50 Cycles	
7	Electro-Static Discharge	HBM : ±2kv	

Note 1: Test after 24 hours in room temperature(23±5°C).

Note 2: The sampling above is individually for each reliability testing condition.

Note 3: The color fading of polarizing filter should not care.

Note 4: All of the reliability testing chamber above, is using D.I. water.(Min value:1.0 MΩ-cm)

Note 5: In case of malfunction defect caused by ESD damage, if it would be recovered to normal state after resetting, it would be judged as a good part.