

ILLUMINANT 北極光企業有限公司

PRODUCT SPECIFICATION FOR TFT LCM

CUSTOMER:	
MODEL NO:	I2812-7IPT2432A
ACCEPTED BY:	

APPROVED BY:	CHECKED BY:	ORGANIZED BY:
		

Approval for Specifications Only

Approval for Specifications and Sample

Note: 1. Version of Specifications : 1

2. Others: Rohs Compliment

TAIWAN

1F, #15, LANE 75, MIN CHUAN E. RD., SEC 3, TAIPEI, TAIWAN.

Tel +886-2-25175115 Fax +886-2-25175099

CHINA

5F DONGWU COMMERICAL BLDG, LANSHAN RD., NORTH DISTRICT, HI-TECH INDUSTRIAL PARK, SHENZHEN, PRC.

TEL + 86-755-86154466 FAX +86-755-86154366

KOREA

RM 1201, IT MIRAE TOWER, 60-21, GASAN-DONG, GEUMCHEON-GU, SEOUL, 153-801, KOREA

TEL + 82-2-2027-5391~2 FAX +82-2-2027-5393

ILLUMINANT

Version	Date	Contents
1	2009/12/30	New Version

CONTENTS

- 1. Mechanical Specification**
- 2. Absolute Maximum Ratings**
- 3. Electrical Characteristics**
- 4. Optical Characteristics**
- 5. Interface**
- 6. Timing Characteristics**
- 7. Backlight**
- 8. Reliability**
- 9. Inspection Criteria**

1.Mechanical Specification:

Item	Standard Value	Unit
Display size	2.83	inch
Module Dimension	69.2(H)*50.0(W)*3.7(D)	mm
Active Area(LCD)	43.2(W)*57.6(H)	mm
Viewing Area(T/P)	44.8(W)*63.1(H)	mm
Number of Dots	240(W)*3(RGB)*320(H)	Dot
LCD Type	TFT / Transmissive / Normal white	-
Viewing Direction	12H	-
Driver	ILI9328	-
Approx. Weight	TBD	g
Various color Display	262	K
Luminance	200	cd/m ²
Backlight Type	4-LED parallel	
Backlight Color	White	

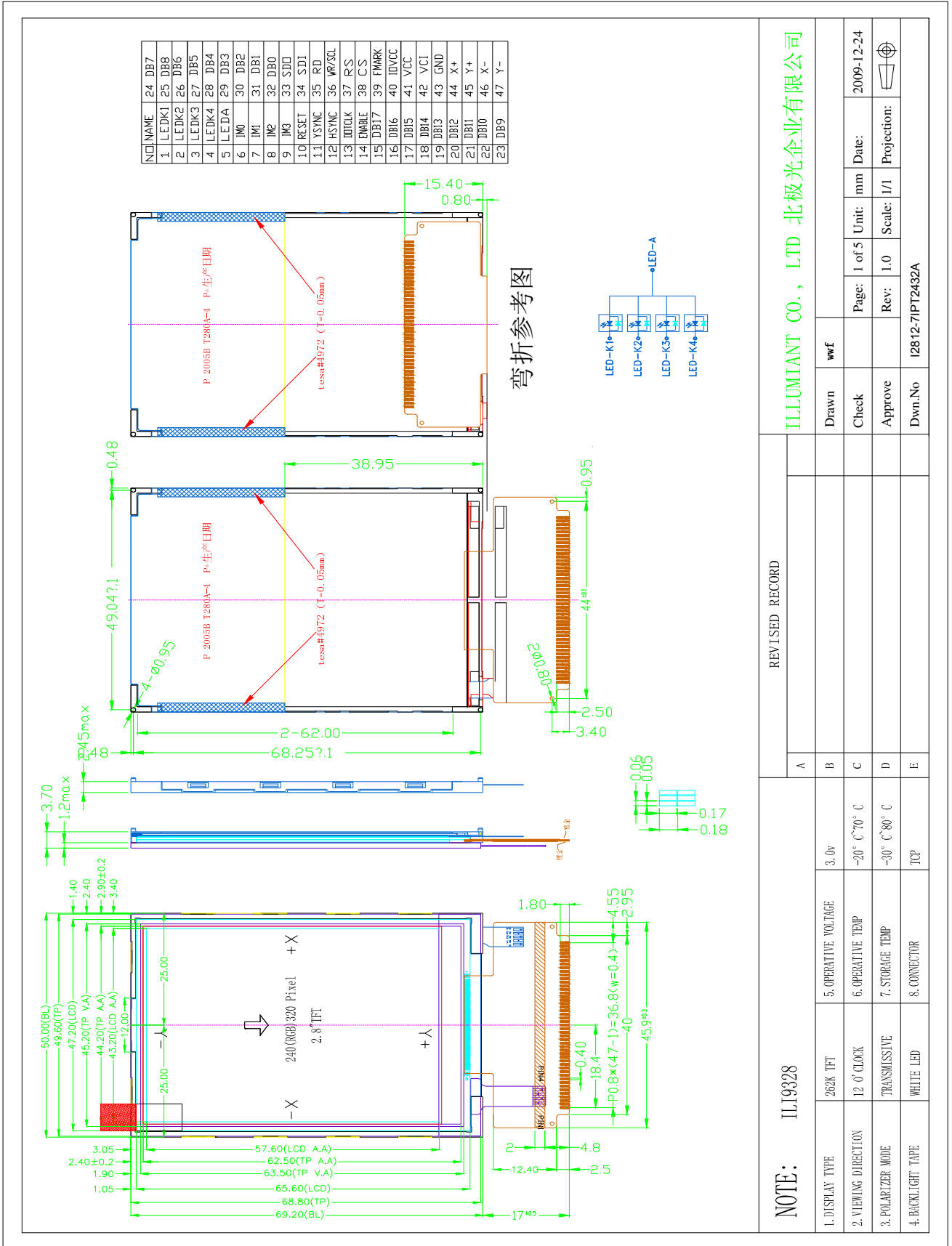

NOTE: IL19328		REVISED RECORD	
1. DISPLAY TYPE	282K TFT	A	
2. VIEWING DIRECTION	12 O' CLOCK	B	
3. POLARIZER MODE	TRANSMISSIVE	C	
4. BACKLIGHT TAPE	WHITE LED	D	
5. OPERATIVE VOLTAGE	3.0V	E	
6. OPERATIVE TEMP	-20° C~70° C		
7. STORAGE TEMP	-30° C~80° C		
8. CONNECTOR	TOP		
Drawn	wwf	Page:	1 of 5
Check		Unit:	mm
Approve		Rev:	1.0
Down.No	12812-7IPT2432A	Scale:	I/1
Date:	2009-12-24	Projection:	⊕

2. Absolute Maximum Ratings:

Item	Symbol	Min.	Typ.	Max.	Unit	Remark
Supply Voltage for Logic	V _{DD}	-0.3		+4.0	V	
Input voltage	V _{IN}	-0.5		V _{DD} +0.3	V	
Operating Temperature	T _{OP}	-10	-	+60	°C	-
Storage Temperature	T _{ST}	-20	-	+70	°C	-

*NOTE: Based on V_{SS}=0V.

3. Electrical Characteristics:

Item	Symbol	Condition	Min.	Typ.	Max.	Unit
Supply Voltage for Logic	V _{DD}	T _a =25 °C	2.4	2.8	3.3	V
High-level input voltage	V _{IHC}	V _{DD} =2.8V	0.8V _{DD}	-	V _{DD}	
Low-level input voltage	V _{ILC}	V _{DD} =2.8V	-0.3	-	0.2V _{DD}	
TFT Gate ON Voltage	V _{GH}	V _{DD} =2.8V	--	15	--	-
TFT Gate OFF Voltage	V _{GL}	V _{DD} =2.8V	--	-8	--	V
TFT Common Electrode Voltage	V _{COMH}	V _{DD} =2.8V	2.5	-	4.5	
	V _{CONL}	V _{DD} =2.8V	-2.0	-	0	
Power Supply Current for V _{DD}	I _{DD}	V _{DD} =2.8V	-	-	7	mA

ILLUMINANT

4. Optical Characteristics:

Parameter	Symbol	Min.	Typ.	Max.	Unit	Note
Transmittance	T(%)		5.8		%	Fig.1
Luminance	I	180	200		cd/m	
Contrast Ratio	C/R	-	300			
Response time	Tr		10		ms	Fig.3
Response time	Tf		15		ms	Fig.3
CIE Color coordinate	Rx	-	0.6457	-	-	Fig.1
	Ry	-	0.3391	-	-	-
	Gx	-	0.3438	-	-	-
	Gy	-	0.6012	-	-	-
	Bx	-	0.1476	-	-	-
	By	-	0.1110	-	-	-
	Wx	-	0.313	-	-	-
	Wy	-	0.329	-	-	-
*1) Viewing angle	Θl	-	50	-	Degree	C/R>10 Fig.4
	Θr	-	50	-		
	Θu	-	60	-		
	Θd	-	55	-		

ILLUMINANT

Notes :

1. Contrast Ratio(CR) is defined mathematically as :

$$\text{Contrast Ratio} = \frac{\text{Surface Luminance with all white pixels}}{\text{Surface Luminance with all black pixels}}$$

2. Surface luminance is the center point across the LCD surface 500mm from the surface with all pixels displaying white. For more information see FIG 1.

3. Response time is the time required for the display to transition from to black(Rise Time, TrR) and from black to white(Decay Time, TrD). For additional information see FIG 3.

4. Viewing angle is the angle at which the contrast ratio is greater than 10. The angles are determined for the horizontal or x axis and the vertical or y axis with respect to the z axis which

is normal to the LCD surface. For more information see FIG 5.

5. Optimum contrast is obtained by adjusting the LCD Threshold voltage(Vth & Vsat)

FIG. 1 Optical Characteristic Measurement Equipment and Method

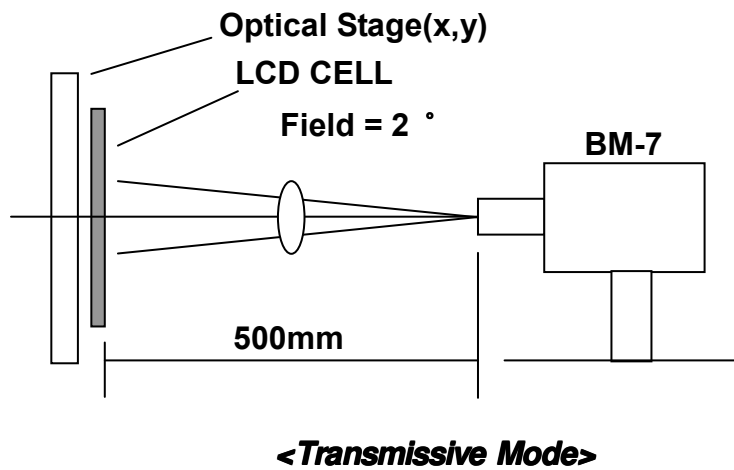

FIG. 2 The definition of V_{th} and V_{sat}

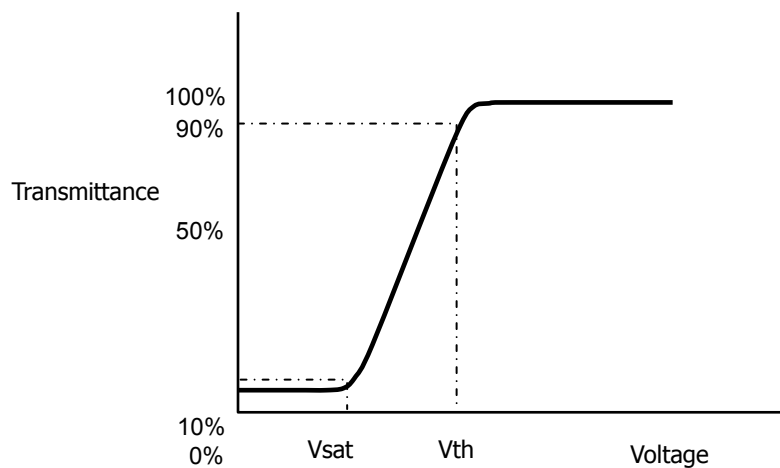
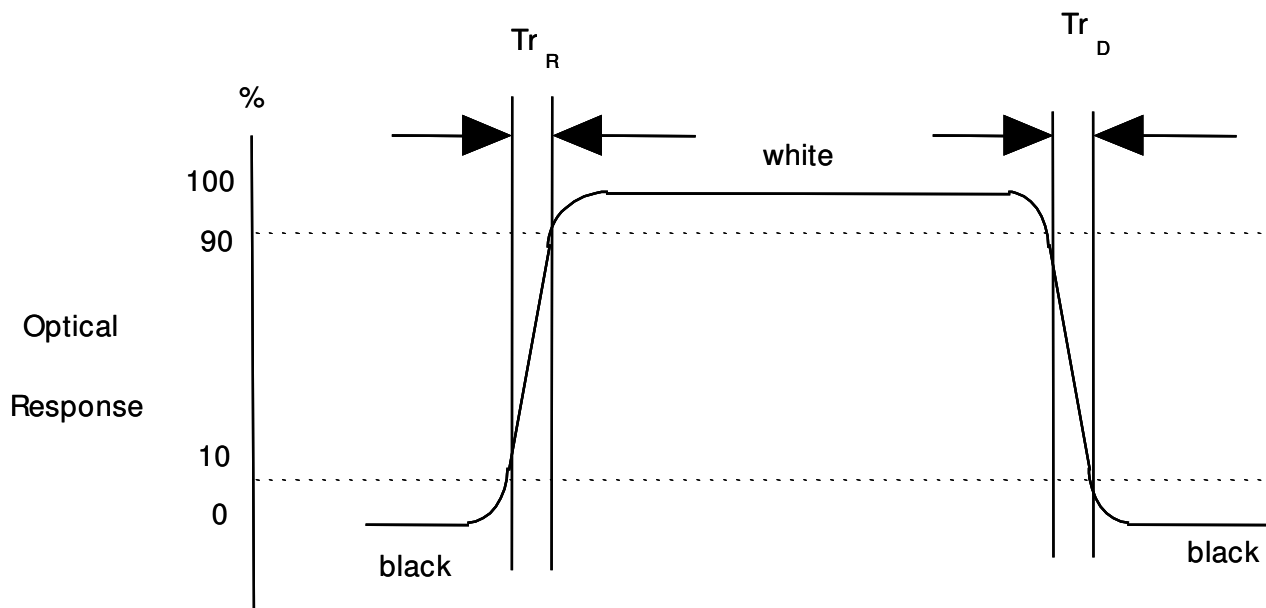

FIG. 3 The definition of Response Time

The response time is defined as the following figure and shall be measured by switching the input signal for “black” and “white”.



ILLUMINANT

FIG. 4 The definition of viewing angle

<dimension of viewing angle range>

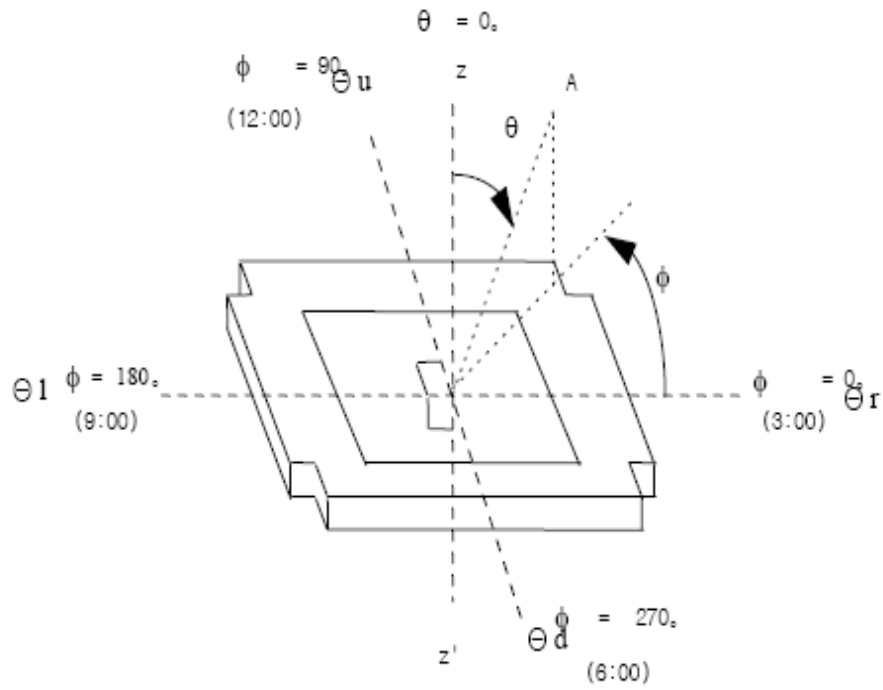

5. Interface:

Pin No.	Symbol	Level	Description
1~4	LEDK1~4	-	LED light cathode
5	LEDA	-	LED light anode
6~9	IM0 IM1 IM2 IM3	H/L	Select a mode to interface to an MPU. In SPI mode, the IM0 pin is used to set the ID of device code.
			IM[3:0] Interface Mode DB Pins
			000* Setting disabled -
			0010 80-system 16-bit interface DB[17:10] DB[8:1]
			0011 80-system 8-bit interface DB[17:10]
			010* Serial peripheral interface (SPI) SDI, SDO
			011* Setting disabled -
			100* Setting disabled -
			1010 80-system 18-bit interface DB[17:0]
			1011 80-system 9-bit interface DB[17:9]
			11** Setting disabled -
10	RESET	H/L	Reset signal
11	VSYNC	H/L	Frame synchronous signal for RGB interface operation
12	HSYNC	H/L	Line synchronous signal for RGB interface operation
13	DOTCLK	H/L	Dot clock signal for RGB interface operation
14	ENABLE	H/L	Data enable signal for RGB interface operation
15~32	DB17~DB0	H/L	Data bus
33	SDO	H/L	Serial data output pin in SPI mode
34	SDI	H/L	Serial data input pin in SPI mode
35	RD	H/L	Read signal
36	WR/SCL	H/L	Write strobe signal in 80-system bus interface operation and enables write operation when WR is low. Synchronous clock signal (SCL) in serial interface operation
37	RS	H/L	Command / data select
38	CS	H/L	Chip selection
39	FMARK	H/L	Frame head pulse signal
40	IOVCC	1.65~3.3V	Interface I/O power supply
41	VCC	2.5~3.3V	Logic regulator power supply
42	VCI	2.5~3.3V	Liquid crystal analog circuit power supply
43	GND	0V	Ground
44	X+	-	Touch panel coordinate in the right side of envisage drawing
45	Y+	-	Touch panel coordinate in the down side of envisage drawing
46	X-	-	Touch panel coordinate in the left side of envisage drawing
47	Y-	-	Touch panel coordinate in the up side of envisage drawing

6. Timing Control:

6.1 I80-system Interface timing characteristics

Normal Write Mode (IOVCC=1.65~3.3V, VCC=2.4~3.3V)

Item		Symbol	Unit	Min.	Typ.	Max.	Test Condition
Bus cycle time	Write	t_{CYCW}	ns	100	-	-	-
	Read	t_{CYCR}	ns	300	-	-	-
Write low-level pulse width		PW_{LW}	ns	50	-	500	-
Write high-level pulse width		PW_{HW}	ns	50	-	-	-
Read low-level pulse width		PW_{LR}	ns	150	-	-	-
Read high-level pulse width		PW_{HR}	ns	150	-	-	-
Write / Read rise / Fall time		t_{WRr}/t_{WRf}	ns	-	-	25	-
Setup time	Write (RS to nCS, E/nWR)	t_{AS}	ns	10	-	-	
	Read (RS to nCS, RW/nRD)			5	-	-	
Address hold time		t_{AH}	ns	5	-	-	-
Write data set up time		t_{DSW}	ns	10	-	-	-
Write data hold time		t_H	ns	15	-	-	-
Read data delay time		t_{DDR}	ns	-	-	100	-
Read data hold time		t_{DHR}	ns	5	-	-	-

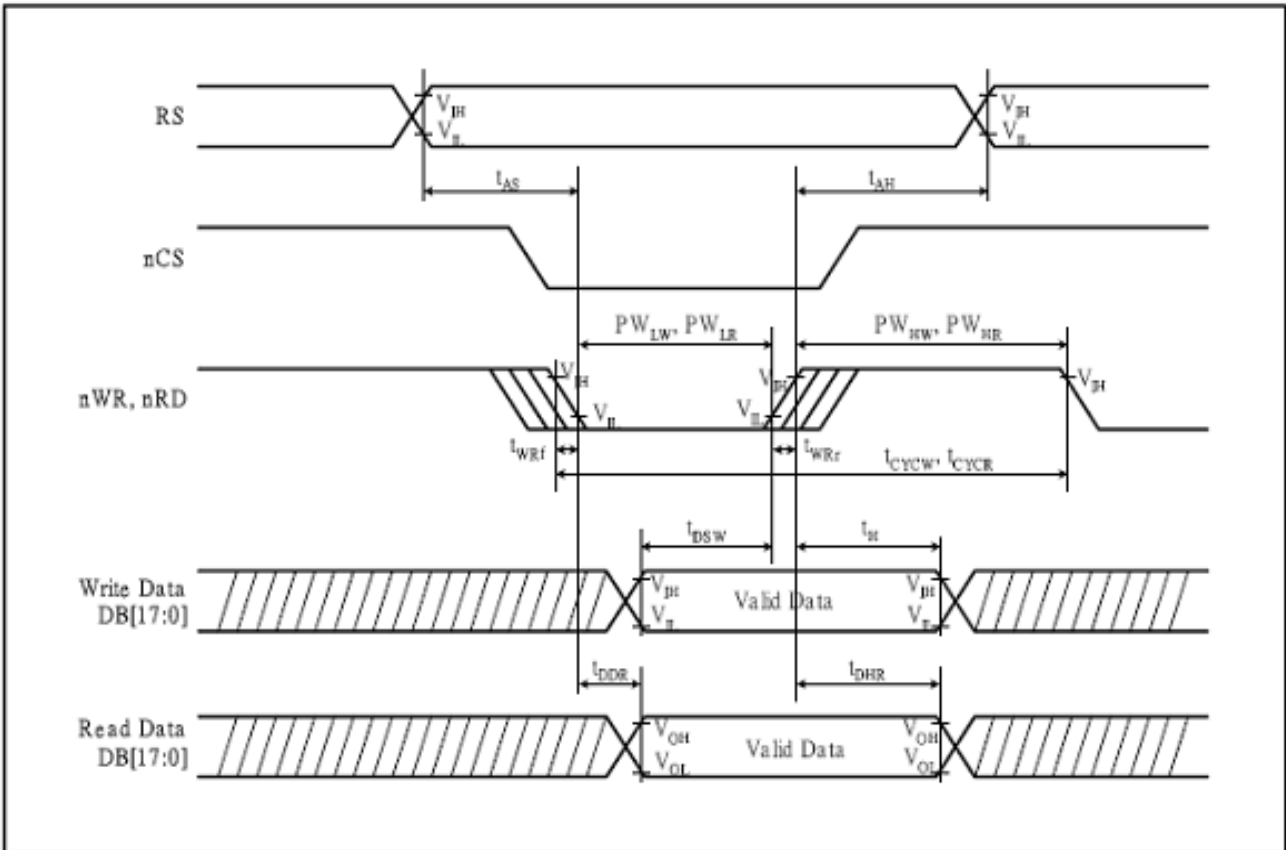

6.2 serial data transfer interface timing characteristics

(IOVCC=1.65~3.3V, VCC=2.4~3.3V)

Item		Symbol	Unit	Min.	Typ.	Max.	Test Condition
Serial clock cycle time	Write(received)	t_{SCYC}	μs	100	-	-	
	Read(transmitted)	t_{SCYC}	μs	200	-	-	
Serial clock high-level Pulse width	Write(received)	t_{SCH}	ns	40	-	-	
	Read(transmitted)	t_{SCH}	ns	100	-	-	
Serial clock low-level Pulse width	Write(received)	t_{SCL}	ns	40	-	-	
	Read(transmitted)	t_{SCL}	ns	100	-	-	
Serial clock rise / fall time		t_{SCR}, t_{SCF}	ns	-	-	5	
Chip select set up time		t_{CSU}	ns	10	-	-	
Chip select hold time		t_{CH}	ns	50	-	-	
Serial input data set up time		t_{SISU}	ns	20	-	-	
Serial input data hold time		t_{SIH}	ns	20	-	-	
Serial output data set up time		t_{SOD}	ns	-	-	100	
Serial output data hold time		t_{SOH}	ns	5	-	-	

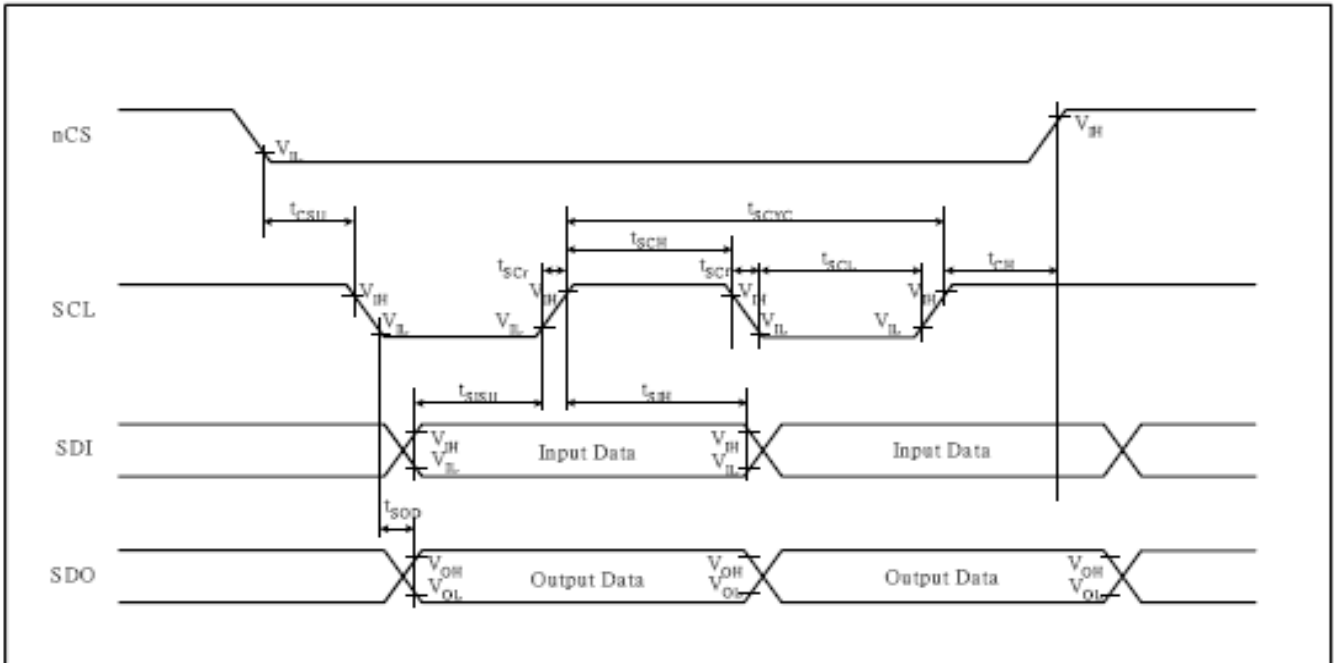

6.3 RGB interface timing characteristics

18/16-bit Bus RGB Interface Mode (IOVCC=1.65~3.3V, VCC=2.4~3.3V)

Item	Symbol	Unit	Min.	Typ.	Max.	Test Condition
VSYNC/HSYNC setup time	t_{SYNCS}	ns	0	-	-	-
ENABLE setup time	t_{ENS}	ns	10	-	-	-
ENABLE hold time	t_{ENH}	ns	10	-	-	-
PD Data setup time	t_{PDS}	ns	10	--	-	-
PD Data hold time	t_{PDH}	ns	40	-	-	-
DOTCLK high-level pulse width	PWDH	ns	40	--	-	-
DOTCLK low-level pulse width	PWDL	ns	40	-	--	-
DOTCLK cycle time	t_{CYCD}	ns	100	-	-	-
DOTCLK, VSYNC, HSYNC, rise/fall time	t_{rgrb} , t_{rgbf}	ns	-	-	25	-

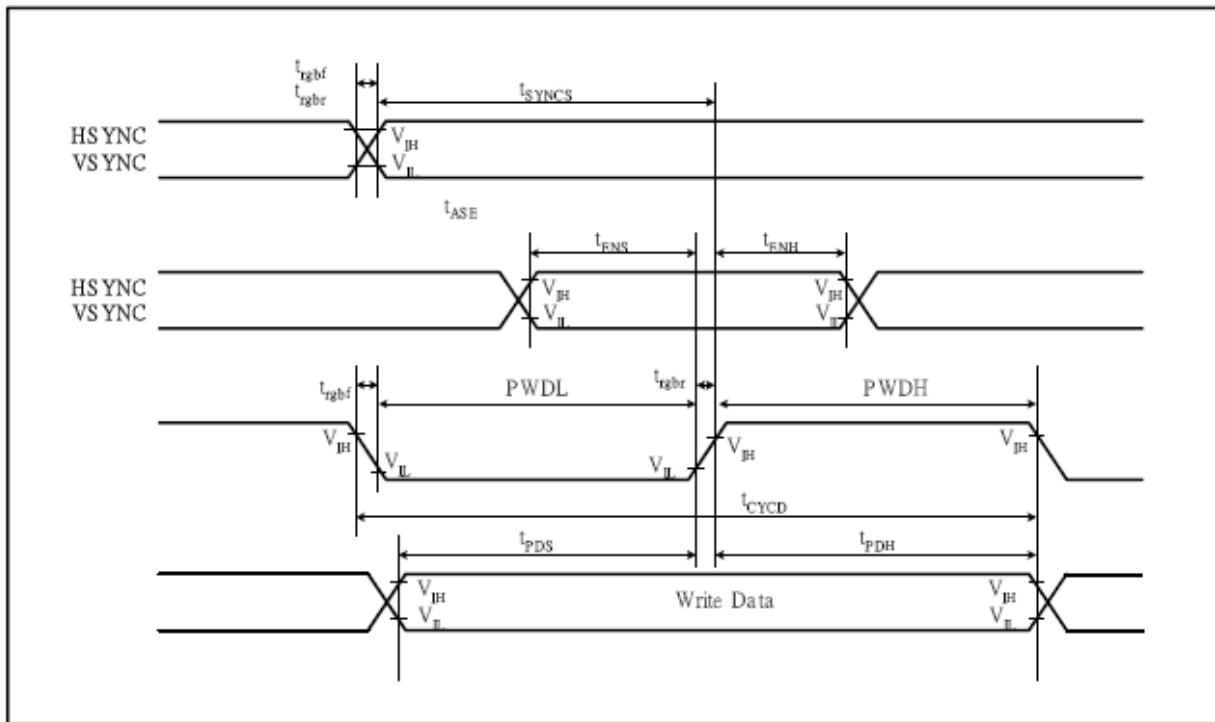

Figure52 RGB Interface Timing

7.Backlight:

7.1 Standard Lamp Styles (Edge Lighting Type):

The LED chips are distributed over the edge light area of the illumination unit, which gives the less power consumption:

7.2 The Main Advantages of the LED Backlight are as Following:

The brightness of the backlight can simply be adjusted. By a resistor or a potentiometer.

7.3 Data About LED Backlight:

PARAMETER	Sym.	Min.	Typ.	Max.	Unit	Test Condition
Forward voltage	Vf	-	3.2	3.5	V	If=60mA
Reverse voltage	Vr	-	-	5.0	V	-
Forward current	If	-	60	80	m A	4-chip parallel
Power Consumption	-	-	192	280	mW	If=60mA
Uniformity(with L/G)	-	80%	-	-	%	If=60mA
Color	White					
Chip connection	4- chip parallel connection					

NOTE:

- 1.Backlight Only
- 2.Average Luminous Intensity of P1-P9
- 3.Uniformity = $\text{Min}(P1 \sim P9) / \text{Max}(P1 \sim P9) * 100\% > 80\%$

7.4 Measured Method:

P1 ○	P2 ○	P3 ○
P4 ○	P5 ○	P6 ○
P7 ○	P8 ○	P9 ○

(Effective spatial Distribution)

Hole Diameter $\pm 1\phi$; 1 to 9per Position Measured Luminous

ILLUMINANT

8. Reliability:

8.1 MTTF

The LCD module shall be designed to meet a minimum MTTF value of 50,000 hours with normal condition. (25°C in the room without sunlight; not include lifetime of backlight and Touch Panel).

8.2 Tests

No.	Item	Condition	Criterion
1	High Temperature Operating	+70°C 240hrs	。 No defect of operational function in room temperature are allowable(23±5°C). 。 Leakage current should be below double of initial value.
2	Low Temperature Operating	-20°C 240hrs	
3	High Temperature Non-Operating	+80°C 240hrs	
4	Low Temperature Non-Operating	-30°C 240hrs	
5	High Temperature / Humidity Non-Operating	60°C ; 90%RH ; 240hrs	
6	Temperature Shock Operating	-20°C ↔ 70°C (30min) (5min) (30min) 50 Cycles	
7	Electro-Static Discharge	HBM : ±2kv	

Note 1: Test after 24 hours in room temperature(23±5°C).

Note 2: The sampling above is individually for each reliability testing condition.

Note 3: The color fading of polarizing filter should not care.

Note 4: All of the reliability testing chamber above, is using D.I. water.(Min value:1.0 MΩ-cm)

Note 5: In case of malfunction defect caused by ESD damage, if it would be recovered to normal state after resetting, it would be judged as a good part.

ILLUMINANT

9. Inspection Criteria:

9.1 Inspection Conditions

9.1.1 Environmental Conditions

The environmental conditions for inspection shall be as follows

Room Temperature : $23 \pm 5^\circ\text{C}$

Humidity : $50 \pm 20\% \text{RH}$

9.1.2 The External Visual Inspection

With 1000 ± 200 lux fluorescent lamp as the light source, the inspection was in the distance of 30cm or more from the LCD to the inspector's eyes .

9.2 Light Method

1. Inspection is implemented over 30cm vertical distance and 30° incidence under 1000 ± 200 lux.
(As showed below)
2. Viewing direction for inspection over 30cm far and is 45° against from LCD
(As showed below)

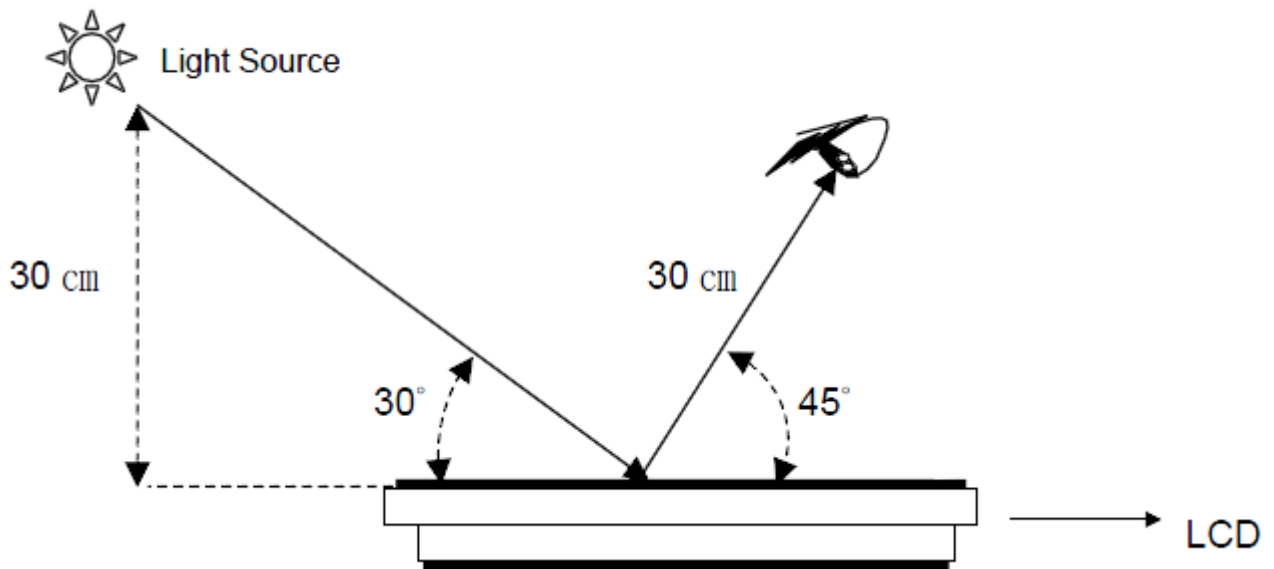

9.3 Classification of Defects

9.3.1 Major Defect

A major defect refers to a defect that may substantially degrade usability for product applications.

ILLUMINANT

9.3.2 Minor Defect

A minor defect refers to a defect which is not considered to be able substantially degrade the product application or a defect that deviates from existing standards almost unrelated to the effective use of the product or its operation.

Notes: If the LCD/LCM's cosmetic and display performance do not specify in "inspection criterion", it should be based on these delivered samples.

9.4 Sampling & Acceptable Quality Level

Inspection Item	Major Defect	Minor Defect
Cosmetic	1.0%	1.5%
Electrical Test	0.4%	0.65%

9.5 Definition of Inspection Area

V/A : Viewing Area

A/A : Active Area

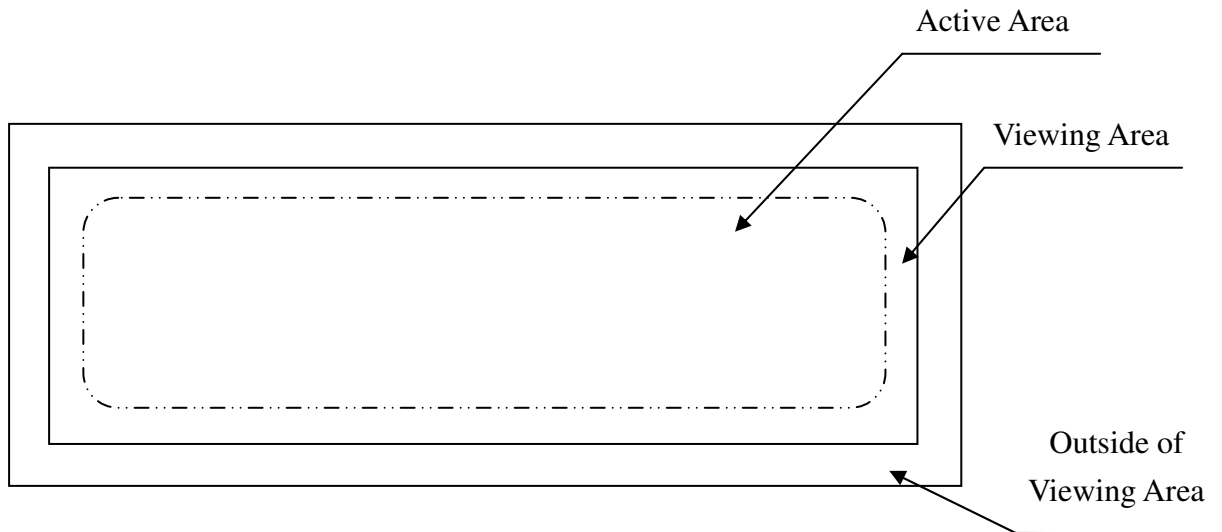

ILLUMINANT

9.6 Items and Criteria

9.6.1 Visual Inspection Criterion in Cosmetic

(1) Glass Defect

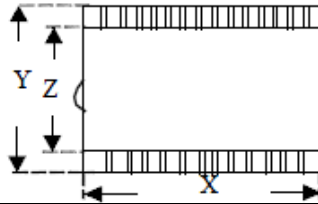
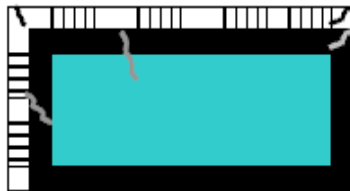
Glass Defect			
No	Defect	Criteria	Remark
1	Dimension (Minor)	By engineering diagram	
2	Cracks (Major)	Extensive crack [Reject]	

(2) LCM Appearance Defect

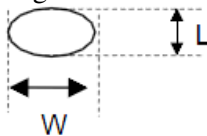
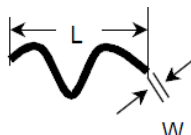
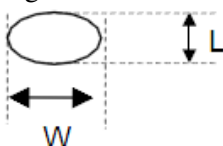
No	Defect	Criteria	Permissible Q'ty	Remark
1	Round Type (Minor)	Spec.	Permissible Q'ty	1. $\Phi = (L+W)/2$, L: Length, W: Width 2. Disregard if out of A.A. 
		$\Phi \leq 0.10\text{mm}$	Disregard	
		$0.10\text{mm} < \Phi \leq 0.20\text{mm}$	3	
		$0.20\text{mm} < \Phi$	0	
2	Line Type (Minor)	Spec.	Permissible Q'ty	1. L: Length, W: Width 2. Disregard if out of A.A. 
		$W \leq 0.03\text{mm}$	Disregard	
		$L \leq 3.0\text{mm}$ and $0.03\text{mm} < W \leq 0.05\text{mm}$	2	
		$L \leq 3.0\text{mm}$ and $0.05\text{mm} < W \leq 0.10\text{mm}$	1	
		$W > 0.10\text{mm}$ or $L > 3.0\text{mm}$	0	
3	Polarizer Dent (Minor)	Spec.	Permissible Q'ty	1. $\Phi = (L+W)/2$, L: Length, W: Width 2. Disregard if out of A.A. 
		$\Phi \leq 0.20\text{mm}$	Disregard	
		$0.20\text{mm} < \Phi \leq 0.30\text{mm}$	2	
		$0.30\text{mm} < \Phi \leq 0.50\text{mm}$	1	
		$0.50\text{mm} < \Phi$	0	

ILLUMINANT

(3) FPC

No	Defect	Criteria	Remark
1	Copper Peeling (Minor)	Copper Peeling [Reject]	

(4) Black Tape

No	Defect	Criteria	Remark
1	Copper Peeling (Minor)	Copper Peeling [Reject]	
2	No Black Tape (Minor)	No Black Tape [Reject]	

(5) Silicon

No	Defect	Criteria	Remark
1	Amount of Silicon (Minor)	ITO exposed [Reject]	

9.6.2 Visual Inspection Criterion in Electrical Display

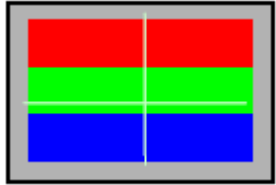
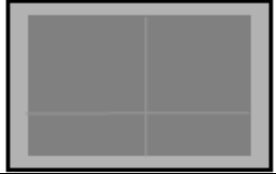
No	Defect	Criteria	Remark	
1	No Display (Major)	Not Allowed		
2	Missing Line (Major)	Not Allowed		
3	Darker or Lighter Line (Major)	Not Allowed		
4	Weak Line (Minor)	By Limited Sample		
5	Bright / Dark Point (Minor)	Spec.	1:1sub-pixel: 1R or 1G or 1B 2:Point defect area $\geq 1/2$ sub pixel.	
		Bright Point		1
		Dark Point		2

ILLUMINANT

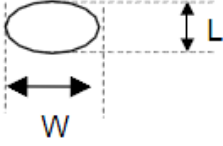
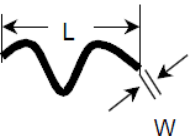
No	Defect	Criteria		Remark
6	Round Type (Minor)	Spec.	Permissible Q'ty	1. $\Phi = (L+W)/2$, L: Length, W: Width 2. Disregard if out of A.A. 
		$\Phi \leq 0.10\text{mm}$	Disregard	
		$0.10\text{mm} < \Phi \leq 0.20\text{mm}$	3	
		$0.20\text{mm} < \Phi$	0	
7	Line Type (Minor)	Spec.	Permissible Q'ty	1. L: Length, W: Width 2. Disregard if out of A.A. 
		$W \leq 0.03\text{mm}$	Disregard	
		$L \leq 3.0\text{mm}$ and $0.03\text{mm} < W \leq 0.05\text{mm}$	2	
		$L \leq 3.0\text{mm}$ and $0.05\text{mm} < W \leq 0.10\text{mm}$	1	
		$W > 0.10\text{mm}$ or $L > 3.0\text{mm}$	0	
8	Mura (Minor)	By 5% ND filter invisible		

9.6.3 Others

- Issues that are not defined in this document shall be discussed and agreed with both parties.
(customer and supplier)
- Unless otherwise agreed upon in writing, the criteria shall be applied to both parties.
(customer and supplier)