



IB235 AND IB290 GAS INFRARED BOOSTER

HOBART

STANDARD FEATURES

- Stainless steel frame.
- Stainless steel legs and adjustable feet.
- Stainless steel 17 gallon tank.
- Stainless steel finned heat exchanger coil.
- Woven ceramic fiber infrared burner.
- 235,000 or 290,000 BTU/hr input.
- Two indicator lights - power on and heat on.
- Two high limit controls, automatic and manual resets.
- ½ H.P. recirculating pump motor.
- 120/60/1 voltage.
- Temperature/pressure relief valve.
- Drain valve.
- Solid state thermostat.
- Blocked vent switch.
- Air flow switch.
- Vent fan control.
- Connections for external air pressure switch.

GAS OPTIONS (must choose one)

- Natural
 Propane

POWER CONTROL OPTIONS (must choose one)

- ON/OFF power switch on booster.
 Integrated power control (with new Hobart dishmachine only).

ACCESSORIES

- Pressure regulating valve.
 Shock arrestor, pressure regulating valve, pressure gauge kit.
 Inlet temperature gauge.

BOOSTER SIZING CHART

Gas Input MBH		Recovery Rate @ 180°F (82.2°C)				
		Inlet Water Temperature				
		110°	120°	130°	140°	150°
235	GPH	322	376	451	564	752
	GPM	5.37	6.27	7.52	9.4	12.54
290	GPH	398	464	557	696	928
	GPM	6.63	7.74	9.28	11.6	15.47
280	GPH	384	448	538	672	896
	GPM	6.40	7.47	8.96	11.2	14.94

Ratings shown are for elevations up to 2,000 feet. For elevations over 2,000 feet, reduce ratings at the rate of 4% for each 1,000 feet above sea level.

SPECIFICATIONS

Hobart Model IB _____ which provides _____ GPH (_____ GPM) of 180°F (82°C) rinse water when supplied with _____ BTU/Hr. of natural or propane gas. Shall have a stainless steel frame, legs, and adjustable feet with a stainless steel 17 gallon tank which meets the requirements of the ASME Boiler and Pressure Vessel Code. Equipped with a woven ceramic fiber infrared burner and stainless steel finned heat exchanger coil. Shall be 120 volts, 60 cycle, single phase and include two indicator lights, automatic and manual reset high limit controls, drain valve, air flow switch, temperature/pressure relief valve, and vent fan control. Listed by NSF International and Certified by AGA and CGA. Shall have the capability to comply with the National Fuel Gas Code, NFPA 54.

Net Weight: 420 lbs.

Shipping Weight: 490 lbs.

VENTILATION

Before installing any method of venting, contact the local code authority or your gas supplier to make sure that the final installation will be acceptable to the authorities who have jurisdiction. The proper method of venting is explained in detail in the National Fuel Gas Code. Also see our Installation Manual.

Details and Dimensions on Reverse Side.



IB235 AND IB290 GAS INFRARED BOOSTER

IB235 AND IB290 GAS INFRARED BOOSTER



GAS BOOSTER HEATERS

GAS PRESSURE TO THE BURNER (CUSTOMER CONNECTION) SHOULD NOT EXCEED 14" W.C. (NATURAL) OR 13" W.C. (PROPANE)

IF GAS PRESSURE IS HIGHER THAN 14" W.C. (NATURAL) OR 13" W.C. (PROPANE), A PRESSURE REGULATING VALVE MUST BE INSTALLED (BY OTHERS) IN THE GAS LINE TO THE BOOSTER. GAS PRESSURE FLOWING TO THE BURNER (CUSTOMER CONNECTION) SHOULD NOT BE LESS THAN 4.5" W.C. (NATURAL) OR 11" W.C. (PROPANE).

GAS HEAT BTU INPUT - IB235 235,000 NATURAL
IB290 290,000 NATURAL
IB290 280,000 PROPANE

PLUMBING NOTES:
RECOMMENDED WATER HARDNESS TO BE 4-6 GRAINS PER GALLON FOR BEST RESULTS.

RECOMMENDED BUILDING FLOWING WATER PRESSURE TO THE DISHWASHER IS 20 PSI, (15 PSI MIN - 25 PSI MAX).

MISCELLANEOUS NOTES:

ALL DIMENSIONS TAKEN FROM FLOOR LINE CAN BE INCREASED OR DECREASED BY 5/8".

WARNING

ELECTRICAL AND GROUNDING CONNECTIONS MUST COMPLY WITH THE APPLICABLE PORTIONS OF THE NATIONAL ELECTRICAL CODE AND/OR OTHER LOCAL ELECTRICAL CODES.

PLUMBING CONNECTIONS MUST COMPLY WITH APPLICABLE SANITARY, SAFETY AND PLUMBING CODES.

VENTING CONNECTIONS MUST COMPLY WITH APPLICABLE VENTING CODES FOR CATEGORY III APPLIANCES

MODEL	ELECTRIC SPECS.	RATED AMPS	MINIMUM SUPPLY CONDUCTOR AMPACITY	MAXIMUM PROTECTIVE DEVICE
IB235	120/60/1	9.5	15	15
IB290	120/60/1	9.0	15	15

NET WEIGHT OF MACHINE: 420 LBS.
DOMESTIC SHIPPING WEIGHT: 490 LBS.

CONNECTION INFORMATION

LEGEND

- (P1) COMMON WATER CONNECTION: 180 DEG F WATER OUT, 3/4" NPT.
- (P2) PRESSURE/TEMPERATURE RELIEF VALVE (PROVIDED) 3/4" FPT
- (P3) GAS CONNECTION -NATURAL OR PROPANE 3/4" FPT
- (P4) COMMON WATER CONNECTION: 140 DEG F WATER IN, 3/4" MPT.
- (P5) TANK DRAIN CONNECTION (VALVE PROVIDED) 3/4" FPT
- (V1) GAS FLUE EXHAUST: 4" DIA.
- (E1) ELEC. CONNECTION: SERVICE CONNECTION, 1/2" CONDUIT
- (E2) ELEC. CONNECTION: DISHWASHER CONTROL CIRCUIT AND VENT FAN INTERLOCK (IF REQUIRED), 1/2" CONDUIT
- (E3) ELEC. CONNECTION: VENT SYSTEM (AIR PRESSURE SWITCH AND VENT FAN CONTROL), 1/2" CONDUIT

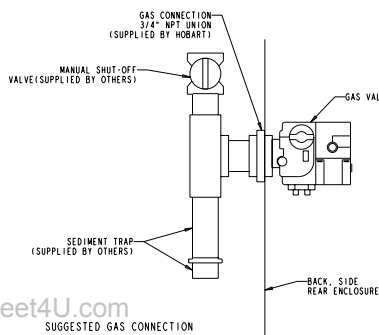
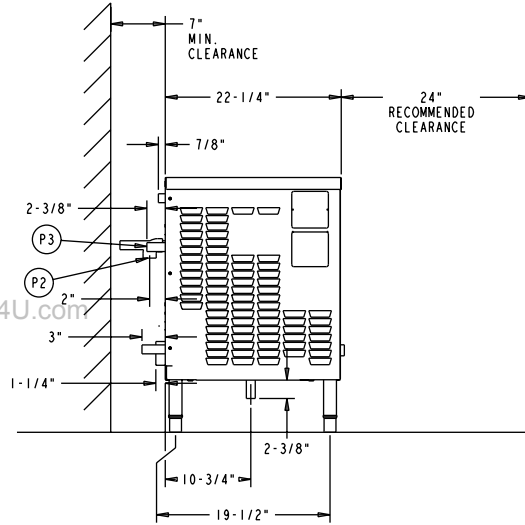
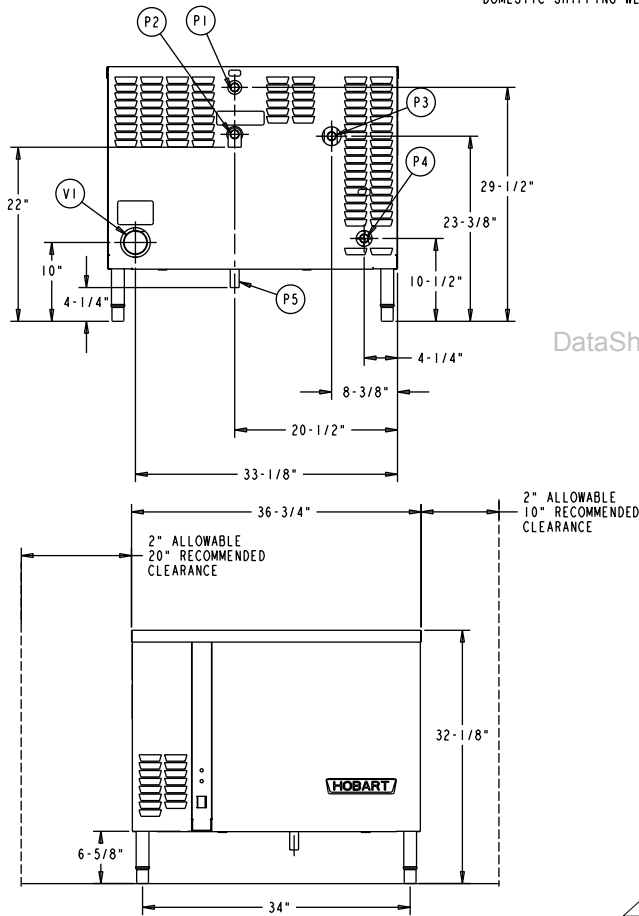

FOR NON-COMBUSTIBLE SURFACES:
VENT PIPE CLEARANCES TO BE .5" MIN.

FOR COMBUSTIBLE SURFACES:
A HORIZONTAL PIPE MUST HAVE 6" MIN. CLEARANCE ABOVE PIPE, AND .5" MIN. CLEARANCE AROUND ITS DIAMETER.
A VERTICAL PIPE MUST HAVE .5" MIN. CLEARANCE AROUND ITS DIAMETER.

70" MAX HORIZONTAL RUN (FOR EACH ADDITIONAL ELBOW MORE THAN 4, REDUCE MAX LENGTH TO 1")

3" 90° SST VENT ELBOW (SHIPPED LOOSE WITH MACHINE) (ORIENTATION OF ELBOW DEPENDENT ON INDIVIDUAL SITE)

3" x 4" VENT ADAPTER (SHIPPED LOOSE WITH MACHINE)

SUGGESTED VENTING THROUGH KITCHEN EXHAUST SYSTEM
(FOR ALTERNATE VENTING RECOMMENDATIONS CONTACT YOUR HOBART REP. OR REFER TO THE NATIONAL FUEL GAS CODE).

