

PowerPC 405GPr Embedded Processor Data Sheet

Features

- IBM PowerPC® 405 32-bit RISC processor core operating up to 400MHz with 16KB I- and D-caches
- PC-133 synchronous DRAM (SDRAM) interface
 - 32-bit interface for non-ECC applications
 - 40-bit interface serves 32 bits of data plus 8 check bits for ECC applications
- 4KB on-chip memory (OCM)
- External peripheral bus
 - Flash ROM/Boot ROM interface
 - Direct support for 8-, 16-, or 32-bit SRAM and external peripherals
 - Up to eight devices
 - External Mastering supported
- DMA support for external peripherals, internal UART and memory
 - Scatter-gather chaining supported
 - Four channels
- PCI Revision 2.2 compliant interface (32-bit, up to 66MHz)
 - Synchronous or asynchronous PCI Bus interface
 - Internal or external PCI Bus Arbiter
- Ethernet 10/100Mbps (full-duplex) support with media independent interface (MII)
- Programmable interrupt controller supports 13 external and 19 internal edge triggered or level-sensitive interrupts
- Programmable timers
- Two serial ports (16550 compatible UART)
- One IIC interface
- General purpose I/O (GPIO) available
- Supports JTAG for board level testing
- Internal processor local Bus (PLB) runs at SDRAM interface frequency
- Supports PowerPC processor boot from PCI memory
- Unique software-accessible 64-bit chip ID number (ECID).

Description

Designed specifically to address embedded applications, the PowerPC 405GPr (PPC405GPr) provides a high-performance, low-power solution that interfaces to a wide range of peripherals by incorporating on-chip power management features and lower power dissipation requirements.

This chip contains a high-performance RISC processor core, SDRAM controller, PCI bus interface, Ethernet interface, control for external ROM and peripherals, DMA with scatter-gather

support, serial ports, IIC interface, and general purpose I/O.

Technology: IBM CMOS SA-27E, 0.18 μm (0.11 μm L_{eff})

Package: 456-ball (35mm or 27mm) enhanced plastic ball grid array (E-PBGA)

Power (typical): 0.72W at 266MHz

PowerPC 405GPr Embedded Processor Data Sheet

Contents

| | |
|--|----|
| Ordering, PVR, and JTAG Information | 4 |
| Address Map Support | 6 |
| On-Chip Memory (OCM) | 8 |
| PLB to PCI Interface | 8 |
| SDRAM Memory Controller | 9 |
| External Peripheral Bus Controller (EBC) | 9 |
| DMA Controller | 10 |
| Serial Interface | 11 |
| IIC Bus Interface | 11 |
| General Purpose IO (GPIO) Controller | 12 |
| Universal Interrupt Controller (UIC) | 12 |
| 10/100 Mbps Ethernet MAC | 12 |
| JTAG | 12 |
| Signal List | 28 |
| Spread Spectrum Clocking | 44 |
| Strapping | 52 |

Tables

| | |
|---|----|
| System Memory Address Map | 6 |
| DCR Address Map | 7 |
| Signals Listed Alphabetically | 15 |
| Signals Listed by Ball Assignment | 25 |
| Pin Summary | 28 |
| Signal Functional Description | 30 |
| Absolute Maximum Ratings | 38 |
| Package Thermal Specifications | 38 |
| Recommended DC Operating Conditions | 39 |
| Input Capacitance | 40 |
| DC Electrical Characteristics | 41 |
| Clocking Specifications | 43 |
| Peripheral Interface Clock Timings | 45 |
| I/O Specifications—Group 1 | 47 |
| I/O Specifications—Group 2 | 50 |
| PPC405GPr Legacy Mode Strapping Pin Assignments | 52 |
| PPC405GPr New Mode Strapping Pin Assignments | 54 |



PowerPC 405GPr Embedded Processor Data Sheet

Figures

| | |
|--|----|
| PPC405GPr Embedded Controller Functional Block Diagram | 5 |
| 27mm, 456-Ball E-PBGA Package | 13 |
| 35mm, 456-Ball E-PBGA Package | 14 |
| 5V-Tolerant Input Current | 40 |
| Input Setup and Hold Waveform | 46 |
| Output Delay and Float Timing Waveform | 46 |

PowerPC 405GPr Embedded Processor Data Sheet

Ordering, PVR, and JTAG Information

| Product Name | Order Part Number ¹ | Processor Frequency | Package | Rev Level | PVR Value | JTAG ID |
|--------------|--------------------------------|---------------------|------------------|-----------|------------|------------|
| PPC405GPr | IBM25PPC405GPr3BB266 | 266MHz | 35mm, 456 E-PBGA | B | 0x50910951 | 0x24088049 |
| PPC405GPr | IBM25PPC405GPr3BB266Z | 266MHz | 35mm, 456 E-PBGA | B | 0x50910951 | 0x24088049 |
| PPC405GPr | IBM25PPC405GPr3DB266 | 266MHz | 27mm, 456 E-PBGA | B | 0x50910951 | 0x24088049 |
| PPC405GPr | IBM25PPC405GPr3DB266Z | 266MHz | 27mm, 456 E-PBGA | B | 0x50910951 | 0x24088049 |
| PPC405GPr | IBM25PPC405GPr3BB333 | 333MHz | 35mm, 456 E-PBGA | B | 0x50910951 | 0x24088049 |
| PPC405GPr | IBM25PPC405GPr3BB333Z | 333MHz | 35mm, 456 E-PBGA | B | 0x50910951 | 0x24088049 |
| PPC405GPr | IBM25PPC405GPr3DB333 | 333MHz | 27mm, 456 E-PBGA | B | 0x50910951 | 0x24088049 |
| PPC405GPr | IBM25PPC405GPr3DB333Z | 333MHz | 27mm, 456 E-PBGA | B | 0x50910951 | 0x24088049 |
| PPC405GPr | IBM25PPC405GPr3BB400 | 400MHz | 35mm, 456 E-PBGA | B | 0x50910951 | 0x24088049 |
| PPC405GPr | IBM25PPC405GPr3BB400Z | 400MHz | 35mm, 456 E-PBGA | B | 0x50910951 | 0x24088049 |
| PPC405GPr | IBM25PPC405GPr3DB400 | 400MHz | 27mm, 456 E-PBGA | B | 0x50910951 | 0x24088049 |
| PPC405GPr | IBM25PPC405GPr3DB400Z | 400MHz | 27mm, 456 E-PBGA | B | 0x50910951 | 0x24088049 |

Note 1: Z at the end of the Order Part Number indicates a tape and reel shipping package. Otherwise, the chips are shipped in a tray.

This section provides the part number nomenclature. For availability, contact your local IBM sales office.

The part number contains a part modifier. Included in the modifier is a revision code. This refers to the die mask revision number and is specified in the part numbering scheme for identification purposes only.

The PVR (Processor Version Register) is software accessible and contains additional information about the revision level of the part. Refer to the *PowerPC 405GPr Embedded Processor User's Manual* for details on the register content.

Order Part Number Key

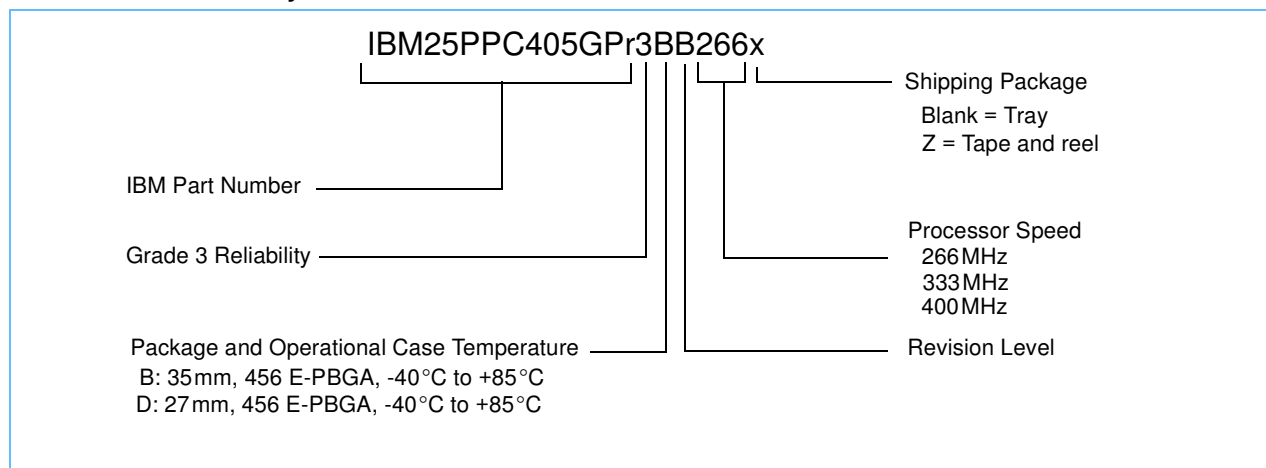

PowerPC 405GPr Embedded Processor Data Sheet

PPC405GPr Embedded Controller Functional Block Diagram

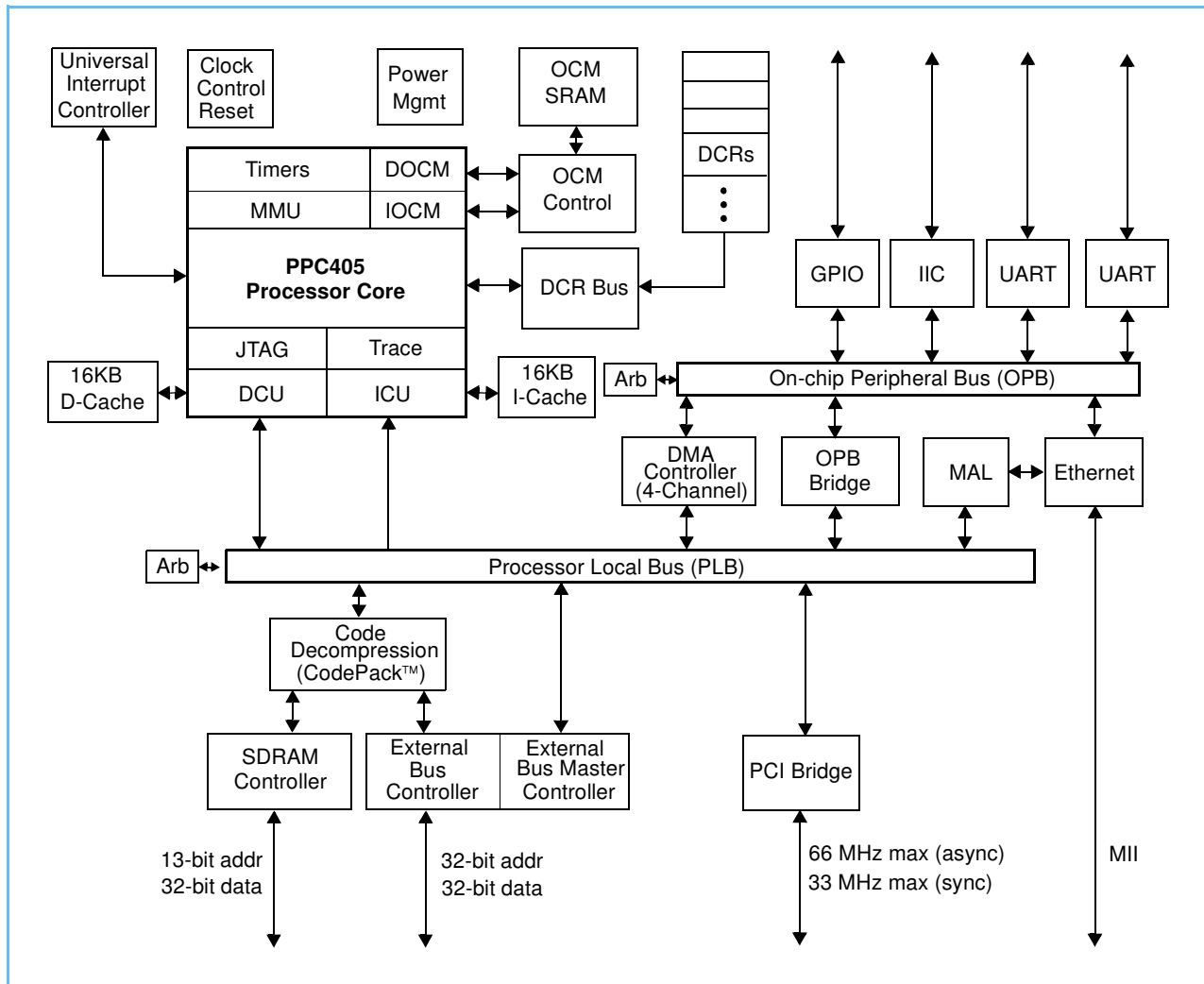

The PPC405GPr is designed using the IBM Microelectronics Blue Logic™ methodology in which major functional blocks are integrated together to create an application-specific ASIC product. This approach provides a consistent way to create complex ASICs using IBM CoreConnect™ Bus Architecture.

PowerPC 405GPr Embedded Processor Data Sheet

Address Map Support

The PPC405GPr incorporates two simple and separate address maps. The first address map defines the possible use of address regions that the processor can access. The second address map is for Device Configuration Registers (DCRs). The DCRs are accessed by software running on the PPC405GPr processor through the use of **mtdcr** and **mfdcr** instructions.

System Memory Address Map 4GB System Memory

| Function | Subfunction | Start Address | End Address | Size |
|----------------------|--|---------------|-------------|--------|
| General Use | SDRAM, External Peripherals, and PCI Memory Note: Any of the address ranges listed at right may be use for any of the above functions. | 0x00000000 | 0xE7FFFFFF | 3712MB |
| | | 0xE8010000 | 0xE87FFFFFF | 8MB |
| | | 0xEC000000 | 0xEEBFFFFFF | 44MB |
| | | 0xEEE00000 | 0xEF3FFFFFF | 6MB |
| | | 0xEF500000 | 0xEF5FFFFFF | 1MB |
| | | 0xF0000000 | 0xFFFFFFFF | 256MB |
| Boot-up | Peripheral Bus Boot ¹ | 0xFFE00000 | 0xFFFFFFFF | 2MB |
| | PCI Boot ² | 0xFFFE0000 | 0xFFFFFFFF | 128KB |
| PCI | PCI I/O | 0xE8000000 | 0xE800FFFF | 64KB |
| | PCI I/O | 0xE8800000 | 0xEBFFFFFF | 56MB |
| | Configuration Registers | 0xEEC00000 | 0xEEC00007 | 8B |
| | Interrupt Acknowledge and Special Cycle | 0xEED00000 | 0xEED00003 | 4B |
| | Local Configuration Registers | 0xEF400000 | 0xEF40003F | 64B |
| Internal Peripherals | UART0 | 0xEF600300 | 0xEF600307 | 8B |
| | UART1 | 0xEF600400 | 0xEF600407 | 8B |
| | IIC0 | 0xEF600500 | 0xEF60051F | 32B |
| | OPB Arbiter | 0xEF600600 | 0xEF60063F | 64B |
| | GPIO Controller Registers | 0xEF600700 | 0xEF60077F | 128B |
| | Ethernet Controller Registers | 0xEF600800 | 0xEF6008FF | 256B |

Notes:

1. When peripheral bus boot is selected, peripheral bank 0 is automatically configured at reset to the address range listed above.
2. If PCI boot is selected, a PLB-to-PCI mapping is automatically configured at reset to the address range listed above.
3. After the boot process, software may reassign the boot memory regions for other uses.
4. All address ranges not listed above are reserved.



PowerPC 405GPr Embedded Processor Data Sheet

DCR Address Map 4KB Device Configuration Registers

| Function | Start Address | End Address | Size |
|--|---------------|-------------|------------------------|
| Total DCR Address Space¹ | 0x000 | 0x3FF | 1KW (4KB) ¹ |
| By function: | | | |
| Reserved | 0x000 | 0x00F | 16W |
| Memory Controller Registers | 0x010 | 0x011 | 2W |
| External Bus Controller Registers | 0x012 | 0x013 | 2W |
| Decompression Controller Registers | 0x014 | 0x015 | 2W |
| Reserved | 0x016 | 0x017 | 2W |
| On-Chip Memory Controller Registers | 0x018 | 0x01F | 8W |
| Reserved | 0x020 | 0x07F | 96W |
| PLB Registers | 0x080 | 0x08F | 16W |
| Reserved | 0x090 | 0x09F | 16W |
| OPB Bridge Out Registers | 0x0A0 | 0x0A7 | 8W |
| Electronic Chip ID (ECID) | 0x0A8 | 0x0A9 | 2W |
| Reserved | 0x0AA | 0x0AF | 6W |
| Clock, Control, Interrupt Routing, and Reset | 0x0B0 | 0x0B7 | 8W |
| Power Management | 0x0B8 | 0x0BF | 8W |
| Interrupt Controller | 0x0C0 | 0x0CF | 16W |
| Reserved | 0x0D0 | 0x0FF | 48W |
| DMA Controller Registers | 0x100 | 0x13F | 64W |
| Reserved | 0x140 | 0x17F | 64W |
| Ethernet MAL Registers | 0x180 | 0x1FF | 128W |
| Reserved | 0x200 | 0x3FF | 512W |

Notes:

1. DCR address space is addressable with up to 10 bits (1024 or 1K unique addresses). Each unique address represents a single 32-bit (word) register, or 1 kiloword (KW) (which equals 4 KB).

PowerPC 405GPr Embedded Processor Data Sheet

On-Chip Memory (OCM)

The OCM feature comprises a memory controller and a one-port 4KB static RAM (SRAM) accessed by the processor core.

Features include:

- Low-latency access to critical instructions and data
- Performance identical to cache hits without misses
- Contents change only under program control

PLB to PCI Interface

The PLB to PCI interface core provides a mechanism for connecting PCI devices to the local PowerPC processor and local memory. This interface is compliant with version 2.2 of the PCI Specification.

Features include:

- Internal PCI bus arbiter for up to six external devices at PCI bus speeds up to 66MHz. Internal arbiter use is optional and can be disabled for systems which employ an external arbiter.
- PCI bus frequency up to 66MHz
 - Synchronous operation at 1/n fractions of PLB speed (n = 1 to 4) to 33MHz maximum
 - Asynchronous operation from 1/8 PLB frequency to 66MHz maximum
- 32-bit PCI address/data bus
- Power Management:
 - PCI Bus Power Management v1.1 compliant
- Supports 1:1, 2:1, 3:1, 4:1 clock ratios from PLB to PCI
- Buffering between PLB and PCI:
 - PCI target 64-byte write post buffer
 - PCI target 96-byte read prefetch buffer
 - PLB slave 32-byte write post buffer
 - PLB slave 64-byte read prefetch buffer
- Error tracking/status
- Supports PCI target side configuration
- Supports processor access to all PCI address spaces:
 - Single-byte PCI I/O reads and writes
 - PCI memory single-beat and prefetch-burst reads and single-beat writes
 - Single-byte PCI configuration reads and writes (type 0 and type 1)

PowerPC 405GPr Embedded Processor Data Sheet

- PCI interrupt acknowledge
- PCI special cycle
- Supports PCI target access to all PLB address spaces
- Supports PowerPC processor boot from PCI memory

SDRAM Memory Controller

The PPC405GPr Memory Controller core provides a low latency access path to SDRAM memory. A variety of system memory configurations are supported. The memory controller supports up to four physical banks. Up to 256MB per bank are supported, up to a maximum of 1 GB. Memory timings, address and bank sizes, and memory addressing modes are programmable.

Features include:

- 11x8 to 13x11 addressing for SDRAM (2- and 4-bank)
- 32-bit memory interface support
- Programmable address compare for each bank of memory
- Industry standard 168-pin DIMMS are supported (some configurations)
- All PPC405GPrs support up to 133 MHz memory with PC-133 support
- 4MB to 256MB per bank
- Programmable address mapping and timing
- Auto refresh
- Page mode accesses with up to 4 open pages
- Power management (self-refresh)
- Error checking and correction (ECC) support
 - Standard single-error correct, double-error detect coverage
 - Aligned nibble error detect
 - Address error logging

External Peripheral Bus Controller (EBC)

- Supports eight banks of ROM, EPROM, SRAM, Flash memory, or slave peripherals
- Up to 66MHz operation
- Burst and non-burst devices
- 8-, 16-, 32-bit byte-addressable data bus width support
- Latch data on Ready

PowerPC 405GPr Embedded Processor Data Sheet

- Programmable 2K clock time-out counter with disable for Ready
- Programmable access timing per device
 - 0–255 wait states for non-bursting devices
 - 0–31 burst wait states for first access and up to 7 wait states for subsequent accesses
 - Programmable C_{SON}, C_{SOFF} relative to address
 - Programmable O_{EON}, W_{EON}, W_{EOFF} (0 to 3 clock cycles) relative to CS
- Programmable address mapping
- Peripheral Device pacing with external “Ready”
- External master interface
 - Write posting from external master
 - Read prefetching on PLB for external master reads
 - Bursting capable from external master
 - Allows external master access to all non-EBC PLB slaves
 - External master can control EBC slaves for own access and control

DMA Controller

- Supports the following transfers:
 - Memory-to-memory transfers
 - Buffered peripheral to memory transfers
 - Buffered memory to peripheral transfers
- Four channels
- Scatter/gather capability for programming multiple DMA operations
- 8-, 16-, 32-bit peripheral support (OPB and external)
- 32-bit addressing
- Address increment or decrement
- Internal 32-byte data buffering capability
- Supports internal and external peripherals
- Support for memory mapped peripherals
- Support for peripherals running on slower frequency buses

PowerPC 405GPr Embedded Processor Data Sheet

Serial Interface

- One 8-pin UART and one 4-pin UART interface provided
- Selectable internal or external serial clock to allow a wide range of baud rates
- Register compatibility with NS16550 register set
- Complete status reporting capability
- Transmitter and receiver are each buffered with 16-byte FIFOs when in FIFO mode
- Fully programmable serial-interface characteristics
- Supports DMA using internal DMA engine

IIC Bus Interface

- Compliant with Philips® Semiconductors I²C Specification, dated 1995
- Operation at 100kHz or 400kHz
- 8-bit data
- 10- or 7-bit address
- Slave transmitter and receiver
- Master transmitter and receiver
- Multiple bus masters
- Supports fixed V_{DD} IIC interface
- Two independent 4 x 1 byte data buffers
- Fifteen memory-mapped, fully programmable configuration registers
- One programmable interrupt request signal
- Provides full management of all IIC bus protocol
- Programmable error recovery

PowerPC 405GPr Embedded Processor Data Sheet

General Purpose IO (GPIO) Controller

- Controller functions and GPIO registers are programmed and accessed via memory-mapped OPB bus master accesses
- 23 of 24 GPIOs are pin-shared with other functions. DCRs control whether a particular pin that has GPIO capabilities acts as a GPIO or is used for another purpose. The 23 GPIOs are multiplexed with:
 - 7 of 8 chip selects
 - All 13 external interrupts
 - All nine instruction trace pins
- Each GPIO output is separately programmable to emulate an open-drain driver (i.e., drives to zero, three-stated if output bit is 1)

Universal Interrupt Controller (UIC)

The Universal Interrupt Controller (UIC) provides the control, status, and communications necessary between the various sources of interrupts and the local PowerPC processor.

Features include:

- Supports 13 external and 19 internal interrupts
 - Seven of the 13 interrupts are mapped to the same GPIOs as the PPC405GP.
 - The other six interrupts can be mapped to any of the GPIOs.
- Edge triggered or level-sensitive
- Positive or negative active
- Non-critical or critical interrupt to processor core
- Programmable critical interrupt priority ordering
- Programmable critical interrupt vector for faster vector processing

10/100 Mbps Ethernet MAC

- Capable of handling full/half duplex 100Mbps and 10Mbps operation
- Uses the medium independent interface (MII) to the physical layer (PHY not included on chip)

JTAG

- IEEE 1149.1 test access port
- IBM RISCWatch debugger support
- JTAG Boundary Scan Description Language (BSDL)

PowerPC 405GPr Embedded Processor Data Sheet

27mm, 456-Ball E-PBGA Package

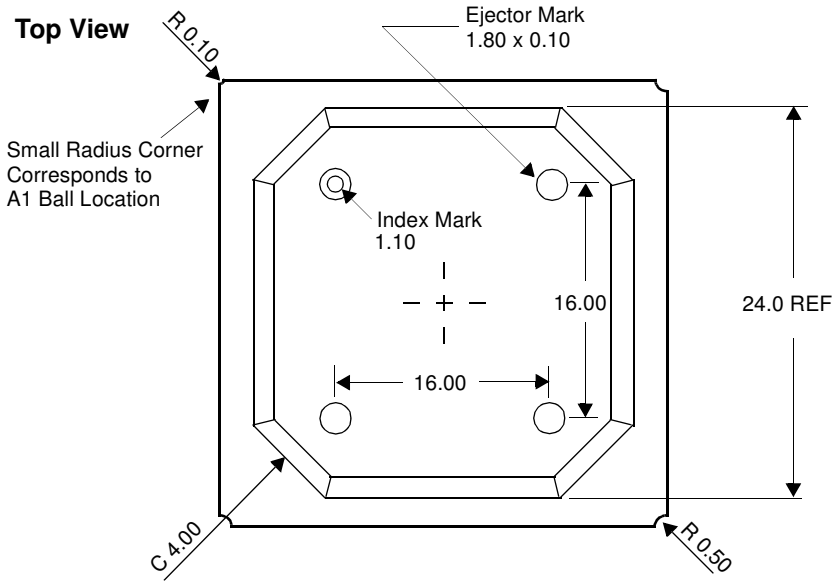

Note: All dimensions are in mm.

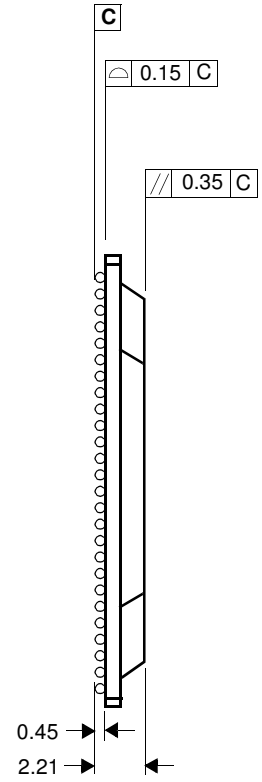
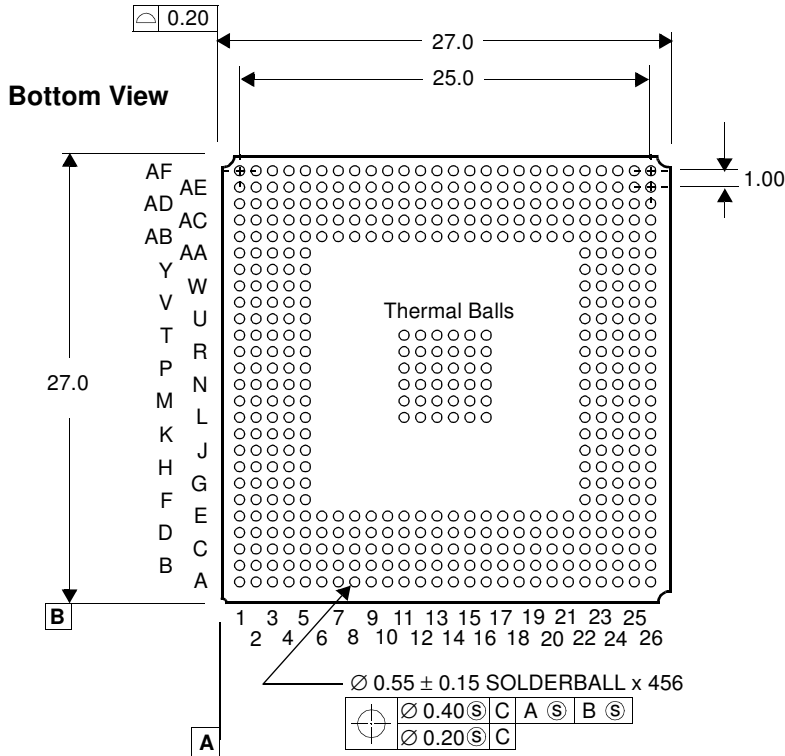

PowerPC 405GPr Embedded Processor Data Sheet

35mm, 456-Ball E-PBGA Package

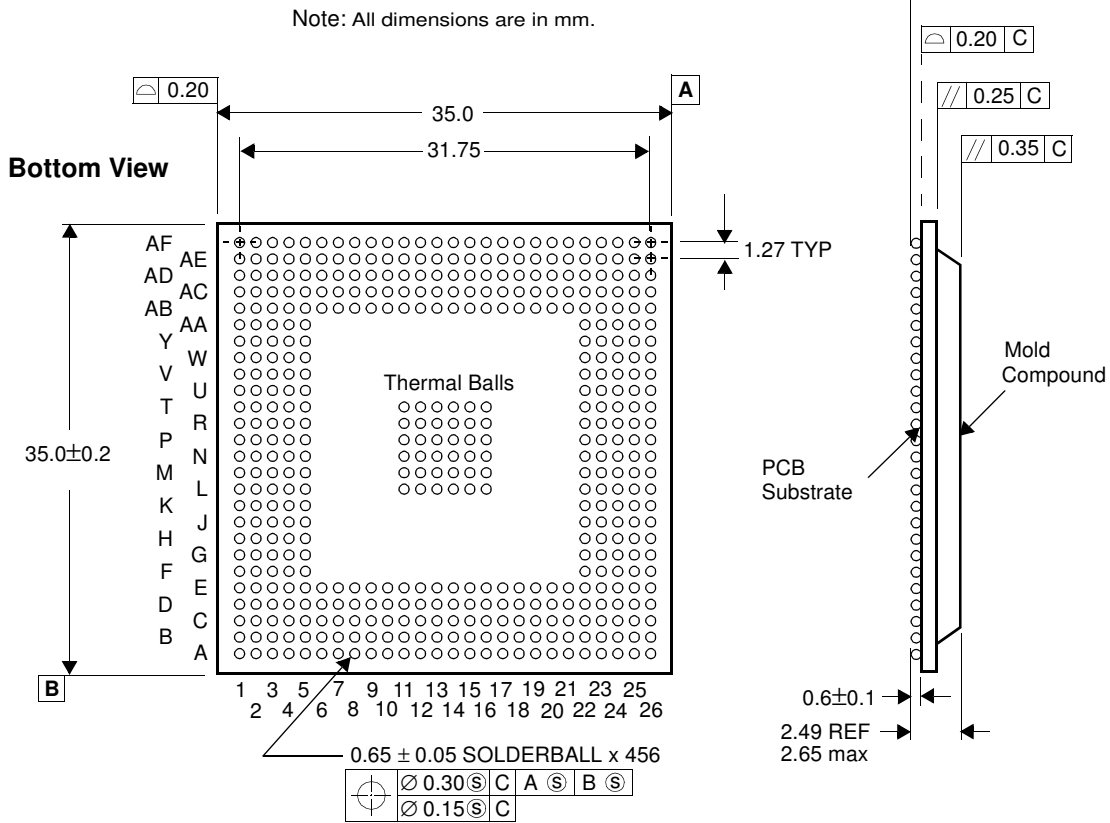
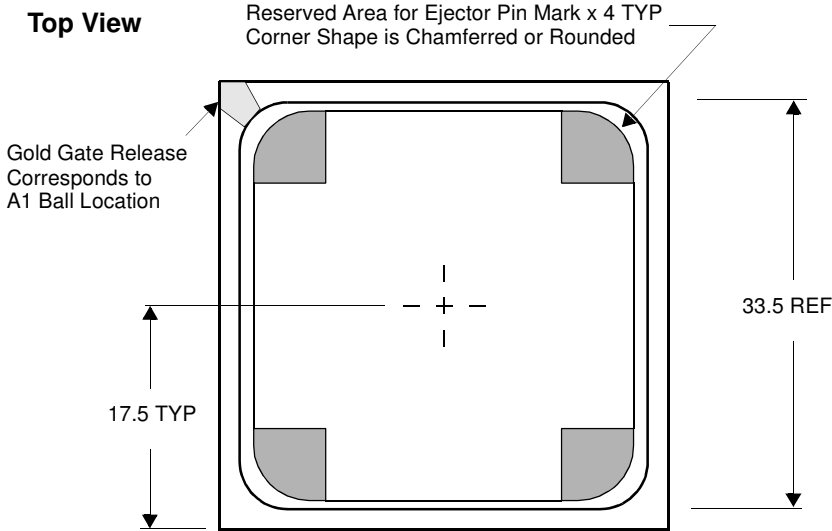

PowerPC 405GPr Embedded Processor Data Sheet

Pin Lists

The PPC405GPr embedded controller is available as a 456-ball E-PBGA package. The 456-ball package is available in two sizes—35 millimeters and 27 millimeters. In this section there are two tables that correlate the external signals to the physical package pin (ball) on which they appear.

The following table lists all the external signals in alphabetical order and shows the ball number on which the signal appears. Multiplexed signals are shown with the default signal (following reset) *not* in brackets and the alternate signal in brackets. Multiplexed signals appear alphabetically multiple times in the list—once for each signal name on the ball. The page number listed gives the page in “Signal Functional Description” on page 30 where the signals in the indicated interface group begin.

Signals Listed Alphabetically (Part 1 of 10)

| Signal Name | Ball | Interface Group | Page |
|--|--|----------------------------|------|
| AGND | E22 | System | 35 |
| AV _{DD} | D25 | System | 35 |
| BA0 BA1 | AB24 AC24 | SDRAM | 32 |
| BankSel0 BankSel1 BankSel2 BankSel3 | AD17 AF17 AE15 AC14 | SDRAM | 32 |
| BE0[PCIC0] BE1[PCIC1] BE2[PCIC2] BE3[PCIC3] | D19 F24 K24 R26 | PCI | 30 |
| BusReq | R3 | External Master Peripheral | 34 |
| CAS | AB23 | SDRAM | 32 |
| ClkEn0 ClkEn1 | AB25 AC25 | SDRAM | 32 |
| DMAAck0 DMAAck1 DMAAck2 DMAAck3 | D16 B15 B14 C12 | External Slave Peripheral | 32 |
| DMAReq0 DMAReq1 DMAReq2 DMAReq3 | C16 D14 C11 A7 | External Slave Peripheral | 32 |
| DQM0 DQM1 DQM2 DQM3 | AC12 AC10 AC6 AA3 | SDRAM | 32 |
| DQMCB | AC15 | SDRAM | 32 |
| ECC0 ECC1 ECC2 ECC3 ECC4 ECC5 ECC6 ECC7 | AE14 AF15 AF14 AD13 AF13 AF12 AE13 AD12 | SDRAM | 32 |
| EMCMDClk | H24 | Ethernet | 31 |
| EMCMDIO[PHYMDIO] | AD26 | Ethernet | 31 |

PowerPC 405GPr Embedded Processor Data Sheet

Signals Listed Alphabetically (Part 2 of 10)

| Signal Name | Ball | Interface Group | Page |
|--|--|---|------|
| EMCTxD0 EMCTxD1 EMCTxD2 EMCTxD3 | J26 L25 L24 P25 | Ethernet | 31 |
| EMCTxEn | K23 | Ethernet | 31 |
| EMCTxErr | K25 | Ethernet | 31 |
| EOT0/TC0 EOT1/TC1 EOT2/TC2 EOT3/TC3 | F3 G2 V2 Y1 | External Slave Peripheral | 32 |
| ExtAck | Y3 | External Master Peripheral | 34 |
| ExtReq | Y4 | External Master Peripheral | 34 |
| ExtReset | T3 | External Master Peripheral | 34 |
| GND | A1 A2 A6 A11 A16 A19 A21 A26 B2 B25 B26 C3 C24 D4 D23 E5 E9 E13 E14 E18 F1 F26 H1 J5 J22 L1 L11-L16 L26 M11-M16 N5 N11-N16 N22 P5 P11-P16 P22 R11-R16 T1 T11-T16 T26 V5 V22 W26 AA1 AA26 AB5 | Ground Note: L11-L16, M11-M16, N11-N16, P11-P16, R11-R16, and T11-T16 are also thermal balls. | 37 |



PowerPC 405GPr Embedded Processor Data Sheet

Signals Listed Alphabetically (Part 3 of 10)

| Signal Name | Ball | Interface Group | Page |
|---|--|---|------|
| GND | AB9 AB13 AB14 AB18 AB22 AC4 AC23 AD3 AD24 AE1 AE2 AE25 AF1 AF6 AF8 AF11 AF16 AF21 AF25 AF26 | Ground Note: L11-L16, M11-M16, N11-N16, P11-P16, R11-R16, and T11-T16 are also thermal balls. | 37 |
| Gnt[PCIReq0] | C19 | PCI | 30 |
| GPIO1[TS1E] GPIO2[TS2E] GPIO3[TS1O] GPIO4[TS2O] GPIO5[TS3] GPIO6[TS4] GPIO7[TS5] GPIO8[TS6] GPIO9[TrcClk] | D18 C20 A22 AF18 AC9 AE8 AF5 AC7 AB3 | System | 35 |
| [GPIO10]PerCS1 [GPIO11]PerCS2 [GPIO12]PerCS3 [GPIO13]PerCS4 [GPIO14]PerCS5 [GPIO15]PerCS6 [GPIO16]PerCS7 | C4 C5 A4 B9 B10 A9 B11 | System | 35 |
| [GPIO17]IRQ0 [GPIO18]IRQ1 [GPIO19]IRQ2 [GPIO20]IRQ3 [GPIO21]IRQ4 [GPIO22]IRQ5 [GPIO23]IRQ6 GPIO24 | V25 V23 W24 W25 Y24 Y25 AA24 D20 | System | 35 |
| Halt | AB26 | System | 35 |
| HoldAck | U2 | External Master Peripheral | 34 |
| HoldPri | T2 | External Master Peripheral | 34 |
| HoldReq | V1 | External Master Peripheral | 34 |
| IIC_SCL | AD6 | Internal Peripheral | 34 |
| IIC_SDA | AE7 | Internal Peripheral | 34 |
| IRQ0[GPIO17] IRQ1[GPIO18] IRQ2[GPIO19] IRQ3[GPIO20] IRQ4[GPIO21] IRQ5[GPIO22] IRQ6[GPIO23] | V25 V23 W24 W25 Y24 Y25 AA24 | Interrupts | 35 |

PowerPC 405GPr Embedded Processor Data Sheet

Signals Listed Alphabetically (Part 4 of 10)

| Signal Name | Ball | Interface Group | Page |
|-------------|------|---|------|
| MemAddr0 | AE22 | SDRAM Note: During a $\overline{\text{CAS}}$ cycle MemAddr0 is the least significant bit (lsb) on this bus. | 32 |
| MemAddr1 | AC21 | | |
| MemAddr2 | AE21 | | |
| MemAddr3 | AD21 | | |
| MemAddr4 | AF22 | | |
| MemAddr5 | AE20 | | |
| MemAddr6 | AC19 | | |
| MemAddr7 | AE19 | | |
| MemAddr8 | AD19 | | |
| MemAddr9 | AC18 | | |
| MemAddr10 | AF19 | | |
| MemAddr11 | AD18 | | |
| MemAddr12 | AC17 | | |
| MemClkOut0 | AC26 | SDRAM | 32 |
| MemClkOut1 | AA23 | | |
| MemData0 | AC13 | SDRAM Note: MemData0 is the most significant bit (msb) on this bus. | 32 |
| MemData1 | AE12 | | |
| MemData2 | AD11 | | |
| MemData3 | AC11 | | |
| MemData4 | AF10 | | |
| MemData5 | AE11 | | |
| MemData6 | AD10 | | |
| MemData7 | AF9 | | |
| MemData8 | AD9 | | |
| MemData9 | AE9 | | |
| MemData10 | AD8 | | |
| MemData11 | AF7 | | |
| MemData12 | AC8 | | |
| MemData13 | AD7 | | |
| MemData14 | AE6 | | |
| MemData15 | AE5 | | |
| MemData16 | AE4 | | |
| MemData17 | AD5 | | |
| MemData18 | AD4 | | |
| MemData19 | AC5 | | |
| MemData20 | AD1 | | |
| MemData21 | AB2 | | |
| MemData22 | AA4 | | |
| MemData23 | AA2 | | |
| MemData24 | AB1 | | |
| MemData25 | Y2 | | |
| MemData26 | W4 | | |
| MemData27 | W2 | | |
| MemData28 | W3 | | |
| MemData29 | V4 | | |
| MemData30 | W1 | | |
| MemData31 | V3 | | |



PowerPC 405GPr Embedded Processor Data Sheet

Signals Listed Alphabetically (Part 5 of 10)

| Signal Name | Ball | Interface Group | Page |
|--|--|--|------|
| OV _{DD} | B17 C13 E6 E7 E8 E19 E20 E21 F5 F22 G5 G22 H5 H22 K2 N24 P3 U25 W5 W22 Y5 Y22 AA5 AA22 AB6 AB7 AB8 AB19 AB20 AB21 AD14 AE10 | Output driver voltage | 37 |
| PCIAD0 PCIAD1 PCIAD2 PCIAD3 PCIAD4 PCIAD5 PCIAD6 PCIAD7 PCIAD8 PCIAD9 PCIAD10 PCIAD11 PCIAD12 PCIAD13 PCIAD14 PCIAD15 PCIAD16 PCIAD17 PCIAD18 PCIAD19 PCIAD20 PCIAD21 PCIAD22 PCIAD23 PCIAD24 PCIAD25 PCIAD26 PCIAD27 PCIAD28 PCIAD29 PCIAD30 PCIAD31 | A17 B16 C17 A18 D17 C18 B18 A20 B21 A23 D21 B22 B23 C22 C26 F25 K26 L23 M25 M23 N25 M26 N26 P24 R24 R23 P23 R25 T24 U26 T25 V26 | PCI Note: PCIAD31 is the most significant bit (msb) on this bus. | 30 |

PowerPC 405GPr Embedded Processor Data Sheet

Signals Listed Alphabetically (Part 6 of 10)

| Signal Name | Ball | Interface Group | Page |
|---|--|-----------------|------|
| PCIC0[BE0] PCIC1[BE1] PCIC2[BE2] PCIC3[BE3] | D19 F24 K24 R26 | PCI | 30 |
| PCIClk | B20 | PCI | 30 |
| PCIDevSel | H25 | PCI | 30 |
| PCIFrame | J24 | PCI | 30 |
| PCIGnt0[Req] PCIGnt1 PCIGnt2 PCIGnt3 PCIGnt4 PCIGnt5 | U23 T23 F23 H26 N23 M24 | PCI | 30 |
| PCIIDSel | P26 | PCI | 30 |
| PCIINT[PerWE] | C23 | PCI | 30 |
| PCIIRDY | J23 | PCI | 30 |
| PCIParity | E26 | PCI | 30 |
| PCIPErr | G25 | PCI | 30 |
| PCIReq0[Gnt] PCIReq1 PCIReq2 PCIReq3 PCIReq4 PCIReq5 | C19 C21 B19 A24 G23 J25 | PCI | 30 |
| PCIReset | B24 | PCI | 30 |
| PCISErr | G24 | PCI | 30 |
| PCIStop | H23 | PCI | 30 |
| PCITRDY | G26 | PCI | 30 |



PowerPC 405GPr Embedded Processor Data Sheet

Signals Listed Alphabetically (Part 7 of 10)

| Signal Name | Ball | Interface Group | Page |
|----------------|------|----------------------------|------|
| PerAddr0 | D5 | External Slave Peripheral | 32 |
| PerAddr1 | A3 | | |
| PerAddr2 | B4 | | |
| PerAddr3 | B5 | | |
| PerAddr4 | D6 | | |
| PerAddr5 | B6 | | |
| PerAddr6 | C6 | | |
| PerAddr7 | D7 | | |
| PerAddr8 | A5 | | |
| PerAddr9 | B7 | | |
| PerAddr10 | C7 | | |
| PerAddr11 | D8 | | |
| PerAddr12 | B8 | | |
| PerAddr13 | C8 | | |
| PerAddr14 | D9 | | |
| PerAddr15 | A8 | | |
| PerAddr16 | C9 | | |
| PerAddr17 | D10 | | |
| PerAddr18 | C10 | | |
| PerAddr19 | A10 | | |
| PerAddr20 | D11 | | |
| PerAddr21 | B12 | | |
| PerAddr22 | D13 | | |
| PerAddr23 | D12 | | |
| PerAddr24 | B13 | | |
| PerAddr25 | A12 | | |
| PerAddr26 | A13 | | |
| PerAddr27 | C14 | | |
| PerAddr28 | A14 | | |
| PerAddr29 | A15 | | |
| PerAddr30 | C15 | | |
| PerAddr31 | D15 | | |
| PerBLast | F2 | External Slave Peripheral | 32 |
| PerClk | E4 | External Master Peripheral | 34 |
| PerCS0 | B3 | External Slave Peripheral | 32 |
| PerCS1[GPIO10] | C4 | | |
| PerCS2[GPIO11] | C5 | | |
| PerCS3[GPIO12] | A4 | | |
| PerCS4[GPIO13] | B9 | | |
| PerCS5[GPIO14] | B10 | | |
| PerCS6[GPIO15] | A9 | | |
| PerCS7[GPIO16] | B11 | | |

PowerPC 405GPr Embedded Processor Data Sheet

Signals Listed Alphabetically (Part 8 of 10)

| Signal Name | Ball | Interface Group | Page |
|------------------|------|----------------------------|------|
| PerData0 | U4 | External Slave Peripheral | 32 |
| PerData1 | U3 | | |
| PerData2 | U1 | | |
| PerData3 | T4 | | |
| PerData4 | R2 | | |
| PerData5 | P4 | | |
| PerData6 | R4 | | |
| PerData7 | P2 | | |
| PerData8 | R1 | | |
| PerData9 | P1 | | |
| PerData10 | N3 | | |
| PerData11 | N1 | | |
| PerData12 | M1 | | |
| PerData13 | N2 | | |
| PerData14 | M3 | | |
| PerData15 | M4 | | |
| PerData16 | N4 | | |
| PerData17 | M2 | | |
| PerData18 | L3 | | |
| PerData19 | L4 | | |
| PerData20 | K1 | | |
| PerData21 | L2 | | |
| PerData22 | K3 | | |
| PerData23 | J1 | | |
| PerData24 | K4 | | |
| PerData25 | J3 | | |
| PerData26 | J2 | | |
| PerData27 | J4 | | |
| PerData28 | H3 | | |
| PerData29 | G1 | | |
| PerData30 | H2 | | |
| PerData31 | H4 | | |
| PerErr | B1 | External Master Peripheral | 34 |
| PerOE | C2 | External Slave Peripheral | 32 |
| PerPar0 | D3 | External Slave Peripheral | 32 |
| PerPar1 | G4 | | |
| PerPar2 | G3 | | |
| PerPar3 | E1 | | |
| PerReady | E3 | External Slave Peripheral | 32 |
| PerR/W | C1 | External Slave Peripheral | 32 |
| PerWBE0 | D2 | External Slave Peripheral | 32 |
| PerWBE1 | E2 | | |
| PerWBE2 | F4 | | |
| PerWBE3 | D1 | | |
| [PerWE]PCIINT | C23 | External Slave Peripheral | 32 |
| PHYCol | AA25 | Ethernet | 31 |
| PHYCrS | W23 | Ethernet | 31 |
| PHYRxCIk | AF20 | Ethernet | 31 |
| PHYMDIO[EMCMDIO] | AD26 | Ethernet | 31 |
| PHYRxD0 | AE23 | Ethernet | 31 |
| PHYRxD1 | AF23 | | |
| PHYRxD2 | AC20 | | |
| PHYRxD3 | AD20 | | |
| PHYRxDV | V24 | Ethernet | 31 |
| PHYRxErr | U24 | Ethernet | 31 |
| PHYTxCIk | E25 | Ethernet | 31 |
| RAS | AF24 | SDRAM | 32 |



PowerPC 405GPr Embedded Processor Data Sheet

Signals Listed Alphabetically (Part 9 of 10)

| Signal Name | Ball | Interface Group | Page |
|---|--|--|------|
| Reserved | C25 E23 E24 Y23 Y26 AF4 ¹ | Other Note: AF4 must be tied to OV _{DD} or GND. All other reserved pins should be left unconnected. | 37 |
| Req[PCI $\overline{\text{Gnt0}}$] | U23 | PCI | 30 |
| SysClk | A25 | System | 35 |
| SysErr | AD25 | System | 35 |
| SysReset | D22 | System | 35 |
| TCK | AD22 | JTAG | 35 |
| TDI | AE24 | JTAG | 35 |
| TDO | AD23 | JTAG | 35 |
| TestEn | D26 | System | 35 |
| TmrClk | D24 | System | 35 |
| TMS | AC22 | JTAG | 35 |
| TRST | AE26 | JTAG | 35 |
| [TS1E]GPIO1 [TS2E]GPIO2 [TS1O]GPIO3 [TS2O]GPIO4 [TS3]GPIO5 [TS4]GPIO6 [TS5]GPIO7 [TS6]GPIO8 [TrcClk]GPIO9 | D18 C20 A22 AF18 AC9 AE8 AF5 AC7 AB3 | System | 35 |
| UART0_CTS | AB4 | Internal Peripheral | 34 |
| UART0_DCD | AE18 | Internal Peripheral | 34 |
| UART0_DSR | AE3 | Internal Peripheral | 34 |
| UART0_DTR | AF2 | Internal Peripheral | 34 |
| UART0_RI | AD15 | Internal Peripheral | 34 |
| UART0_RTS | AD16 | Internal Peripheral | 34 |
| UART0_Rx | AE16 | Internal Peripheral | 34 |
| UART0_Tx | AF3 | Internal Peripheral | 34 |
| UART1_CTS/UART1_DSR | AC3 | Internal Peripheral | 34 |
| UART1_DSR/UART1_CTS | AC3 | Internal Peripheral | 34 |
| UART1_DTR/UART1_RTS | AD2 | Internal Peripheral | 34 |
| UART1_RTS/UART1_DTR | AD2 | Internal Peripheral | 34 |
| UART1_Rx | AC1 | Internal Peripheral | 34 |
| UART1_Tx | AC2 | Internal Peripheral | 34 |
| UARTSerClk | AE17 | Internal Peripheral | 34 |



PowerPC 405GPr Embedded Processor Data Sheet

Signals Listed Alphabetically (Part 10 of 10)

| Signal Name | Ball | Interface Group | Page |
|-----------------|------|-----------------|------|
| V _{DD} | E10 | Logic voltage | 37 |
| | E11 | | |
| | E12 | | |
| | E15 | | |
| | E16 | | |
| | E17 | | |
| | K5 | | |
| | K22 | | |
| | L5 | | |
| | L22 | | |
| | M5 | | |
| | M22 | | |
| | R5 | | |
| | R22 | | |
| | T5 | | |
| | T22 | | |
| | U5 | | |
| | U22 | | |
| | AB10 | | |
| | AB11 | | |
| AB12 | | | |
| AB15 | | | |
| AB16 | | | |
| AB17 | | | |
| WE | AC16 | SDRAM | 32 |



PowerPC 405GPr Embedded Processor Data Sheet

Signals Listed by Ball Assignment (Part 1 of 3)

| Ball | Signal Name | Ball | Signal Name | Ball | Signal Name | Ball | Signal Name |
|------|---|------|---|------|------------------------------|------|------------------------------|
| A1 | GND | B14 | DMAAck2 | D1 | $\overline{\text{PerWBE3}}$ | E14 | GND |
| A2 | GND | B15 | DMAAck1 | D2 | $\overline{\text{PerWBE0}}$ | E15 | V _{DD} |
| A3 | PerAddr1 | B16 | PCIAD1 | D3 | PerPar0 | E16 | V _{DD} |
| A4 | $\overline{\text{PerCS3}}[\text{GPIO12}]$ | B17 | OV _{DD} | D4 | GND | E17 | V _{DD} |
| A5 | PerAddr8 | B18 | PCIAD6 | D5 | PerAddr0 | E18 | GND |
| A6 | GND | B19 | $\overline{\text{PCIReq2}}$ | D6 | PerAddr4 | E19 | OV _{DD} |
| A7 | DMAReq3 | B20 | PCIClk | D7 | PerAddr7 | E20 | OV _{DD} |
| A8 | PerAddr15 | B21 | PCIAD8 | D8 | PerAddr11 | E21 | OV _{DD} |
| A9 | $\overline{\text{PerCS6}}[\text{GPIO15}]$ | B22 | PCIAD11 | D9 | PerAddr14 | E22 | AGND |
| A10 | PerAddr19 | B23 | PCIAD12 | D10 | PerAddr17 | E23 | Reserved |
| A11 | GND | B24 | $\overline{\text{PCIReset}}$ | D11 | PerAddr20 | E24 | Reserved |
| A12 | PerAddr25 | B25 | GND | D12 | PerAddr23 | E25 | PHYTxClk |
| A13 | PerAddr26 | B26 | GND | D13 | PerAddr22 | E26 | PCIParity |
| A14 | PerAddr28 | C1 | PerR/ $\overline{\text{W}}$ | D14 | DMAReq1 | F1 | GND |
| A15 | PerAddr29 | C2 | $\overline{\text{PerOE}}$ | D15 | PerAddr31 | F2 | $\overline{\text{PerBLast}}$ |
| A16 | GND | C3 | GND | D16 | DMAAck0 | F3 | EOT0/TC0 |
| A17 | PCIAD0 | C4 | $\overline{\text{PerCS1}}[\text{GPIO10}]$ | D17 | PCIAD4 | F4 | $\overline{\text{PerWBE2}}$ |
| A18 | PCIAD3 | C5 | $\overline{\text{PerCS2}}[\text{GPIO11}]$ | D18 | GPIO1[TS1E] | F5 | OV _{DD} |
| A19 | GND | C6 | PerAddr6 | D19 | PCIC0[BE0] | F22 | OV _{DD} |
| A20 | PCIAD7 | C7 | PerAddr10 | D20 | GPIO24 | F23 | PCIGnt2 |
| A21 | GND | C8 | PerAddr13 | D21 | PCIAD10 | F24 | PCIC1[BE1] |
| A22 | GPIO3[TS10] | C9 | PerAddr16 | D22 | $\overline{\text{SysReset}}$ | F25 | PCIAD15 |
| A23 | PCIAD9 | C10 | PerAddr18 | D23 | GND | F26 | GND |
| A24 | $\overline{\text{PCIReq3}}$ | C11 | DMAReq2 | D24 | TmrClk | G1 | PerData29 |
| A25 | SysClk | C12 | DMAAck3 | D25 | AV _{DD} | G2 | EOT1/TC1 |
| A26 | GND | C13 | OV _{DD} | D26 | $\overline{\text{TestEn}}$ | G3 | PerPar2 |
| B1 | PerErr | C14 | PerAddr27 | E1 | PerPar3 | G4 | PerPar1 |
| B2 | GND | C15 | PerAddr30 | E2 | $\overline{\text{PerWBE1}}$ | G5 | OV _{DD} |
| B3 | $\overline{\text{PerCS0}}$ | C16 | DMAReq0 | E3 | PerReady | G22 | OV _{DD} |
| B4 | PerAddr2 | C17 | PCIAD2 | E4 | PerClk | G23 | $\overline{\text{PCIReq4}}$ |
| B5 | PerAddr3 | C18 | PCIAD5 | E5 | GND | G24 | PCISErr |
| B6 | PerAddr5 | C19 | $\overline{\text{PCIReq0}}[\text{Gnt}]$ | E6 | OV _{DD} | G25 | $\overline{\text{PCIPErr}}$ |
| B7 | PerAddr9 | C20 | GPIO2[TS2E] | E7 | OV _{DD} | G26 | PCITRDY |
| B8 | PerAddr12 | C21 | $\overline{\text{PCIReq1}}$ | E8 | OV _{DD} | H1 | GND |
| B9 | $\overline{\text{PerCS4}}[\text{GPIO13}]$ | C22 | PCIAD13 | E9 | GND | H2 | PerData30 |
| B10 | $\overline{\text{PerCS5}}[\text{GPIO14}]$ | C23 | PCIINT[PerWE] | E10 | V _{DD} | H3 | PerData28 |
| B11 | $\overline{\text{PerCS7}}[\text{GPIO16}]$ | C24 | GND | E11 | V _{DD} | H4 | PerData31 |
| B12 | PerAddr21 | C25 | Reserved | E12 | V _{DD} | H5 | OV _{DD} |
| B13 | PerAddr24 | C26 | PCIAD14 | E13 | GND | H22 | OV _{DD} |

PowerPC 405GPr Embedded Processor Data Sheet

Signals Listed by Ball Assignment (Part 2 of 3)

| Ball | Signal Name | Ball | Signal Name | Ball | Signal Name | Ball | Signal Name |
|------|----------------------------------|------|-----------------------|------|----------------------------------|------|----------------------------|
| H23 | PCIS $\overline{\text{Stop}}$ | M1 | PerData12 | P14 | GND | U1 | PerData2 |
| H24 | EMCMDCIk | M2 | PerData17 | P15 | GND | U2 | HoldAck |
| H25 | PCIDevSel | M3 | PerData14 | P16 | GND | U3 | PerData1 |
| H26 | PCIGnt $\overline{3}$ | M4 | PerData15 | P22 | GND | U4 | PerData0 |
| J1 | PerData23 | M5 | V _{DD} | P23 | PCIAD26 | U5 | V _{DD} |
| J2 | PerData26 | M11 | GND | P24 | PCIAD23 | U22 | V _{DD} |
| J3 | PerData25 | M12 | GND | P25 | EMCTxD3 | U23 | PCIGnt0[Req] |
| J4 | PerData27 | M13 | GND | P26 | PCIIDSel | U24 | PHYRxErr |
| J5 | GND | M14 | GND | R1 | PerData8 | U25 | OV _{DD} |
| J22 | GND | M15 | GND | R2 | PerData4 | U26 | PCIAD29 |
| J23 | PCIIRDY | M16 | GND | R3 | BusReq | V1 | HoldReq |
| J24 | PCIFrame | M22 | V _{DD} | R4 | PerData6 | V2 | EOT2/TC2 |
| J25 | PCIReq $\overline{5}$ | M23 | PCIAD19 | R5 | V _{DD} | V3 | MemData31 |
| J26 | EMCTxD0 | M24 | PCIGnt $\overline{5}$ | R11 | GND | V4 | MemData29 |
| K1 | PerData20 | M25 | PCIAD18 | R12 | GND | V5 | GND |
| K2 | OV _{DD} | M26 | PCIAD21 | R13 | GND | V22 | GND |
| K3 | PerData22 | N1 | PerData11 | R14 | GND | V23 | IRQ1[GPIO18] |
| K4 | PerData24 | N2 | PerData13 | R15 | GND | V24 | PHYRxDV |
| K5 | V _{DD} | N3 | PerData10 | R16 | GND | V25 | IRQ0[GPIO17] |
| K22 | V _{DD} | N4 | PerData16 | R22 | V _{DD} | V26 | PCIAD31 |
| K23 | EMCTxEn | N5 | GND | R23 | PCIAD25 | W1 | MemData30 |
| K24 | PCIC2[$\overline{\text{BE}}2$] | N11 | GND | R24 | PCIAD24 | W2 | MemData27 |
| K25 | EMCTxErr | N12 | GND | R25 | PCIAD27 | W3 | MemData28 |
| K26 | PCIAD16 | N13 | GND | R26 | PCIC3[$\overline{\text{BE}}3$] | W4 | MemData26 |
| L1 | GND | N14 | GND | T1 | GND | W5 | OV _{DD} |
| L2 | PerData21 | N15 | GND | T2 | HoldPri | W22 | OV _{DD} |
| L3 | PerData18 | N16 | GND | T3 | $\overline{\text{ExtReset}}$ | W23 | PHYCrS |
| L4 | PerData19 | N22 | GND | T4 | PerData3 | W24 | IRQ2[GPIO19] |
| L5 | V _{DD} | N23 | PCIGnt $\overline{4}$ | T5 | V _{DD} | W25 | IRQ3[GPIO20] |
| L11 | GND | N24 | OV _{DD} | T11 | GND | W26 | GND |
| L12 | GND | N25 | PCIAD20 | T12 | GND | Y1 | EOT3/TC3 |
| L13 | GND | N26 | PCIAD22 | T13 | GND | Y2 | MemData25 |
| L14 | GND | P1 | PerData9 | T14 | GND | Y3 | $\overline{\text{ExtAck}}$ |
| L15 | GND | P2 | PerData7 | T15 | GND | Y4 | $\overline{\text{ExtReq}}$ |
| L16 | GND | P3 | OV _{DD} | T16 | GND | Y5 | OV _{DD} |
| L22 | V _{DD} | P4 | PerData5 | T22 | V _{DD} | Y22 | OV _{DD} |
| L23 | PCIAD17 | P5 | GND | T23 | PCIGnt $\overline{1}$ | Y23 | Reserved |
| L24 | EMCTxD2 | P11 | GND | T24 | PCIAD28 | Y24 | IRQ4[GPIO21] |
| L25 | EMCTxD1 | P12 | GND | T25 | PCIAD30 | Y25 | IRQ5[GPIO22] |
| L26 | GND | P13 | GND | T26 | GND | Y26 | Reserved |



PowerPC 405GPr Embedded Processor Data Sheet

Signals Listed by Ball Assignment (Part 3 of 3)

| Ball | Signal Name | Ball | Signal Name | Ball | Signal Name | Ball | Signal Name |
|------|------------------|------|-------------------------|------|----------------------|------|-------------|
| AA1 | GND | AB26 | Hal \bar{t} | AD9 | MemData8 | AE18 | UART0_DCD |
| AA2 | MemData23 | AC1 | UART1_Rx | AD10 | MemData6 | AE19 | MemAddr7 |
| AA3 | DQM3 | AC2 | UART1_Tx | AD11 | MemData2 | AE20 | MemAddr5 |
| AA4 | MemData22 | AC3 | UART1_DSR/ UART1_CTS | AD12 | ECC7 | AE21 | MemAddr2 |
| AA5 | OV _{DD} | AC4 | GND | AD13 | ECC3 | AE22 | MemAddr0 |
| AA22 | OV _{DD} | AC5 | MemData19 | AD14 | OV _{DD} | AE23 | PHYRxD0 |
| AA23 | MemClkOut1 | AC6 | DQM2 | AD15 | UART0_R \bar{I} | AE24 | TDI |
| AA24 | IRQ6[GPIO23] | AC7 | GPIO8[TS6] | AD16 | UART0_RTS | AE25 | GND |
| AA25 | PHYCol | AC8 | MemData12 | AD17 | BankSel0 | AE26 | TRST |
| AA26 | GND | AC9 | GPIO5[TS3] | AD18 | MemAddr11 | AF1 | GND |
| AB1 | MemData24 | AC10 | DQM1 | AD19 | MemAddr8 | AF2 | UART0_DTR |
| AB2 | MemData21 | AC11 | MemData3 | AD20 | PHYRxD3 | AF3 | UART0_Tx |
| AB3 | GPIO9[TrcClk] | AC12 | DQM0 | AD21 | MemAddr3 | AF4 | Reserved |
| AB4 | UART0_CTS | AC13 | MemData0 | AD22 | TCK | AF5 | GPIO7[TS5] |
| AB5 | GND | AC14 | BankSel3 | AD23 | TDO | AF6 | GND |
| AB6 | OV _{DD} | AC15 | DQMCB | AD24 | GND | AF7 | MemData11 |
| AB7 | OV _{DD} | AC16 | WE | AD25 | SysErr | AF8 | GND |
| AB8 | OV _{DD} | AC17 | MemAddr12 | AD26 | EMCMDIO [PHYMDIO] | AF9 | MemData7 |
| AB9 | GND | AC18 | MemAddr9 | AE1 | GND | AF10 | MemData4 |
| AB10 | V _{DD} | AC19 | MemAddr6 | AE2 | GND | AF11 | GND |
| AB11 | V _{DD} | AC20 | PHYRxD2 | AE3 | UART0_DSR | AF12 | ECC5 |
| AB12 | V _{DD} | AC21 | MemAddr1 | AE4 | MemData16 | AF13 | ECC4 |
| AB13 | GND | AC22 | TMS | AE5 | MemData15 | AF14 | ECC2 |
| AB14 | GND | AC23 | GND | AE6 | MemData14 | AF15 | ECC1 |
| AB15 | V _{DD} | AC24 | BA1 | AE7 | IICSDA | AF16 | GND |
| AB16 | V _{DD} | AC25 | ClkEn1 | AE8 | GPIO6[TS4] | AF17 | BankSel1 |
| AB17 | V _{DD} | AC26 | MemClkOut0 | AE9 | MemData9 | AF18 | GPIO4[TS20] |
| AB18 | GND | AD1 | MemData20 | AE10 | OV _{DD} | AF19 | MemAddr10 |
| AB19 | OV _{DD} | AD2 | UART1_RTS/ UART1_DTR | AE11 | MemData5 | AF20 | PHYRxClk |
| AB20 | OV _{DD} | AD3 | GND | AE12 | MemData1 | AF21 | GND |
| AB21 | OV _{DD} | AD4 | MemData18 | AE13 | ECC6 | AF22 | MemAddr4 |
| AB22 | GND | AD5 | MemData17 | AE14 | ECC0 | AF23 | PHYRxD1 |
| AB23 | CAS | AD6 | IICSCS | AE15 | BankSel2 | AF24 | RAS |
| AB24 | BA0 | AD7 | MemData13 | AE16 | UART0_Rx | AF25 | GND |
| AB25 | ClkEn0 | AD8 | MemData10 | AE17 | UARTSerClk | AF26 | GND |

PowerPC 405GPr Embedded Processor Data Sheet

Signal List

The following table provides a summary of the number of package pins associated with each functional interface group.

Pin Summary

| Group | No. of Pins |
|--------------------------|-------------|
| PCI | 60 |
| Ethernet | 18 |
| SDRAM | 71 |
| External peripheral | 96 |
| External master | 9 |
| Internal peripheral | 15 |
| Interrupts | 7 |
| JTAG | 5 |
| System | 18 |
| Total Signal Pins | 299 |
| OV _{DD} | 32 |
| V _{DD} | 24 |
| Gnd | 59 |
| Thermal (and Gnd) | 36 |
| Reserved | 6 |
| Total Pins | 456 |

Multiplexed Pins

In the table “Signal Functional Description” on page 30, each external signal is listed along with a description of the signal function. Some signals are multiplexed on the same pin (ball) so that the pin can be used for different functions. Multiplexed signals are shown as a default signal with a secondary signal in square brackets (for example, GPIO1[TS1E]). Active-low signals (for example, $\overline{\text{RAS}}$) are marked with an overline.

It is expected that in any single application a particular pin will always be programmed to serve the same function. The flexibility of multiplexing allows a single chip to offer a richer pin selection than would otherwise be possible.

In addition to multiplexing, many pins are also multi-purpose. For example, the EBC peripheral controller address pins are used as outputs by the PPC405GPr to broadcast an address to external slave devices when the PPC405GPr has control of the external bus. When, during the course of normal chip operation, an external master gains ownership of the external bus, these same pins are used as inputs which are driven by the external master and received by the EBC in the PPC405GPr. In this example, the pins are also bidirectional, serving as both inputs and outputs.

Initialization Strapping

One group of pins is used as strapped inputs during system reset. These pins function as strapped inputs only during reset and are used for other functions during normal operation (see “Strapping” on page 52). Note that the use of these pins for strapping is not considered multiplexing since the strapping function is not programmable.

PowerPC 405GPr Embedded Processor Data Sheet

Pull-Up and Pull-Down Resistors

Pull-up and pull-down resistors are used for strapping during reset and to retain unused or undriven inputs in an appropriate state. The recommended pull-up value of 3k Ω to +3.3V (10k Ω to +5V can be used on 5V tolerant I/Os) and pull-down value of 1k Ω to GND, applies only to individually terminated signals. To prevent possible damage to the device, I/Os capable of becoming outputs *must never* be tied together and terminated through a common resistor.

If your system-level test methodology permits, input-only signals can be connected together and terminated through either a common resistor or directly to +3.3V or GND. When a resistor is used, its value must ensure that the grouped I/Os reach a valid logic zero or logic one state when accounting for the total input current into the PPC405GPr.

Unused I/Os

For some interfaces, it is possible to turn off input receivers for some or all of the signals by means of bit settings in register CPC0_CR1. When this gating capability is applied to unused signals, it is not necessary to terminate them. Refer to the *PowerPC 405GPr Embedded Processor User's Manual* for details.

If receiver gating is not used, termination of some pins may be necessary when they are unused. Although the PPC405GPr requires only the pull-up and pull-down terminations as specified in the "Signal Functional Description" on page 30, good design practice is to terminate all unused inputs or to configure I/Os such that they always drive. If unused, and receiver gating is not used, the peripheral, SDRAM, and PCI buses should be configured and terminated as follows:

- Peripheral interface—PerAddr0:31, PerData0:31, and all of the control signals are driven by default. Terminate PerReady high and PerError low.
- SDRAM—Program SDRAM0_CFG[EMDULR]=1 and SDRAM0_CFG[DCE]=1. This causes the PPC405GPr to actively drive all of the SDRAM address, data, and control signals.
- PCI—The PCI pull-up requirements given in the Signal Functional Description apply only when the PCI interface is being used. When the PCI bridge is unused, configure the PCI controller to park on the bus and actively drive PCIAD31:0, PCIC3:0[BE3:0], and the remaining PCI control signals by doing the following:
 - Strap the PPC405GPr to disable the internal PCI arbiter and to operate the PCI interface in synchronous mode.
 - Individually connect $\overline{\text{PCISerr}}$, $\overline{\text{PCIPerr}}$, $\overline{\text{PCITRDY}}$, and $\overline{\text{PCIStop}}$ through 3k Ω resistors to +3.3V.
 - Terminate $\overline{\text{PCIReq1:5}}$ to +3.3V.
 - Terminate $\overline{\text{PCIReq0[Gnt]}}$ to GND.

External Bus Control Signals

All peripheral bus control signals ($\overline{\text{PerCS0:7}}$, $\overline{\text{PerR/W}}$, $\overline{\text{PerWBE0:3}}$, $\overline{\text{PerOE}}$, $\overline{\text{PerWE}}$, $\overline{\text{PerBLast}}$, HoldAck, ExtAck) are set to the high-impedance state when $\overline{\text{ExtReset}}=0$. In addition, as detailed in the *PowerPC 405GPr Embedded Processor User's Manual*, the peripheral bus controller can be programmed via EBC0_CFG to float some of these control signals between transactions and/or when an external master owns the peripheral bus. As a result, a pull-up resistor should be added to those control signals where an undriven state may affect any devices receiving that particular signal.

The following table lists all of the I/O signals provided by the PPC405GPr. Please refer to "Signals Listed Alphabetically" on page 15 for the pin number to which each signal is assigned.

PowerPC 405GPr Embedded Processor Data Sheet

Signal Functional Description (Part 1 of 8)

Multiplexed signals are shown in brackets following the first signal name assigned to each multiplexed ball.

Notes:

1. Receiver input has hysteresis.
2. Must pull up. See “Pull-Up and Pull-Down Resistors” on page 29 for recommended termination values.
3. Must pull down. See “Pull-Up and Pull-Down Resistors” on page 29 for recommended termination values.
4. If not used, must pull up.
5. If not used, must pull down.
6. Strapping input during reset; pull up or pull down as required.
7. Pull-up may be required. See “External Bus Control Signals” on page 29.

| Signal Name | Description | I/O | Type | Notes |
|----------------------|---|-----|-------------------------|-------|
| PCI Interface | | | | |
| PCIAD31:0 | PCI Address/Data Bus. Multiplexed address and data bus. | I/O | 5V tolerant 3.3V PCI | |
| PCIC3:0[BE3:0] | PCI bus command and byte enables. | I/O | 5V tolerant 3.3V PCI | |
| PCIParity | PCI parity. Parity is even across PCIAD0:31 and PCIC0:3[BE0:3]. PCIParity is valid one cycle after either an address or data phase. The PCI device that drove PCIAD0:31 is responsible for driving PCIParity on the next PCI bus clock. | I/O | 5V tolerant 3.3V PCI | |
| PCIFrame | PCIFrame is driven by the current PCI bus master to indicate the beginning and duration of a PCI access. | I/O | 5V tolerant 3.3V PCI | 2 |
| PCIIRDY | PCIIRDY is driven by the current PCI bus master. Assertion of PCIIRDY indicates that the PCI initiator is ready to transfer data. | I/O | 5V tolerant 3.3V PCI | 2 |
| PCITRDY | The target of the current PCI transaction drives PCITRDY. Assertion of PCITRDY indicates that the PCI target is ready to transfer data. | I/O | 5V tolerant 3.3V PCI | 2 |
| PCIStop | The target of the current PCI transaction can assert PCIStop to indicate to the requesting PCI master that it wants to end the current transaction. | I/O | 5V tolerant 3.3V PCI | 2 |
| PCIDevSel | PCIDevSel is driven by the target of the current PCI transaction. A PCI target asserts PCIDevSel when it has decoded an address and command encoding and claims the transaction. | I/O | 5V tolerant 3.3V PCI | 2 |
| PCIIDSel | PCIIDSel is used during configuration cycles to select the PCI slave interface for configuration. | I | 5V tolerant 3.3V PCI | |
| PCISErr | PCISErr is used for reporting address parity errors or catastrophic failures detected by a PCI target. | I/O | 5V tolerant 3.3V PCI | 2 |
| PCIPErr | PCIPErr is used for reporting data parity errors on PCI transactions. PCIPErr is driven active by the device receiving PCIAD0:31, PCIC0:3[BE0:3], and PCIParity, two PCI clocks following the data in which bad parity is detected. | I/O | 5V tolerant 3.3V PCI | 2 |
| PCIClk | PCIClk is used as the asynchronous PCI clock when in asynchronous mode. It is unused when the PCI interface is operated synchronously with the PLB bus. | I | 5V tolerant 3.3V PCI | |
| PCIReset | PCI specific reset. | O | 5V tolerant 3.3V PCI | |
| PCIINT[PerWE] | PCI interrupt. Open-drain output (two states; 0 or open circuit) or Peripheral write enable. Low when any of the four PerWBE0:3 write byte enables are low. | O | 5V tolerant 3.3V PCI | |
| PCIReq0[Gnt] | Multipurpose signal, used as PCIReq0 when internal arbiter is used, and as Gnt when external arbiter is used. | I | 5V tolerant 3.3V PCI | |

PowerPC 405GPr Embedded Processor Data Sheet

Signal Functional Description (Part 2 of 8)

Multiplexed signals are shown in brackets following the first signal name assigned to each multiplexed ball.

Notes:

1. Receiver input has hysteresis.
2. Must pull up. See “Pull-Up and Pull-Down Resistors” on page 29 for recommended termination values.
3. Must pull down. See “Pull-Up and Pull-Down Resistors” on page 29 for recommended termination values.
4. If not used, must pull up.
5. If not used, must pull down.
6. Strapping input during reset; pull up or pull down as required.
7. Pull-up may be required. See “External Bus Control Signals” on page 29.

| Signal Name | Description | I/O | Type | Notes |
|---------------------------|--|-----|----------------------------|-------|
| PCIReq1:5 | Used as $\overline{\text{PCIReq1:5}}$ input when internal arbiter is used. | I | 5V tolerant 3.3V PCI | |
| PCIGnt0[Req] | $\overline{\text{Gnt0}}$ when internal arbiter is used or $\overline{\text{Req}}$ when external arbiter is used. | O | 5V tolerant 3.3V PCI | |
| PCIGnt1:5 | Used as $\overline{\text{PCIGnt1:5}}$ output when internal arbiter is used. | O | 5V tolerant 3.3V PCI | |
| Ethernet Interface | | | | |
| PHYRxD3:0 | Received data. This is a nibble wide bus from the PHY. The data is synchronous with the PHYRxClk. | I | 5V tolerant 3.3V LVTTTL | 1 |
| EMCTxD3:0 | Transmit data. A nibble wide data bus towards the net. The data is synchronous to the PHYTxClk. | O | 5V tolerant 3.3V LVTTTL | 6 |
| PHYRxErr | Receive Error. This signal comes from the PHY and is synchronous to the PHYRxClk. | I | 5V tolerant 3.3V LVTTTL | 1 |
| PHYRxClk | Receiver Medium clock. This signal is generated by the PHY. | I | 5V tolerant 3.3V LVTTTL | 1 |
| PHYRxDV | Receive Data Valid. Data on the Data Bus is valid when this signal is activated. Deassertion of this signal indicates end of the frame reception. | I | 5V tolerant 3.3V LVTTTL | 1 |
| PHYCrS | Carrier Sense signal from the PHY. This is an asynchronous signal. | I | 5V tolerant 3.3V LVTTTL | 1 |
| EMCTxErr | Transmit Error. This signal is generated by the Ethernet controller, is connected to the PHY and is synchronous with the PHYTxClk. It informs the PHY that an error was detected. | O | 5V tolerant 3.3V LVTTTL | 6 |
| EMCTxEn | Transmit Enable. This signal is driven by the EMAC to the PHY. Data is valid during the active state of this signal. Deassertion of this signal indicates end of frame transmission. This signal is synchronous to the PHYTxClk. | O | 5V tolerant 3.3V LVTTTL | 6 |
| PHYTxClk | This clock comes from the PHY and is the Medium Transmit clock. | I | 5V tolerant 3.3V LVTTTL | 1 |
| PHYCol | Collision signal from the PHY. This is an asynchronous signal. | I | 5V tolerant 3.3V LVTTTL | 1 |
| EMCMDClk | Management Data Clock. The MDClk is sourced to the PHY. This clock has a period of 400ns, adjustable via EMAC0_STACR[OPBC]. Management information is transferred synchronously with respect to this clock. | O | 5V tolerant 3.3V LVTTTL | |
| EMCMDIO[PHYMDIO] | Management Data Input/Output is a bidirectional signal between the Ethernet controller and the PHY. It is used to transfer control and status information. | I/O | 5V tolerant 3.3V LVTTTL | 1 |

PowerPC 405GPr Embedded Processor Data Sheet

Signal Functional Description (Part 3 of 8)

Multiplexed signals are shown in brackets following the first signal name assigned to each multiplexed ball.

Notes:

1. Receiver input has hysteresis.
2. Must pull up. See “Pull-Up and Pull-Down Resistors” on page 29 for recommended termination values.
3. Must pull down. See “Pull-Up and Pull-Down Resistors” on page 29 for recommended termination values.
4. If not used, must pull up.
5. If not used, must pull down.
6. Strapping input during reset; pull up or pull down as required.
7. Pull-up may be required. See “External Bus Control Signals” on page 29.

| Signal Name | Description | I/O | Type | Notes |
|--|--|-----|----------------------------|-------|
| SDRAM Interface | | | | |
| MemData0:31 | Memory data bus. Notes: 1. MemData0 is the most significant bit (msb). 2. MemData31 is the least significant bit (lsb). | I/O | 3.3V LVTTTL | |
| MemAddr12:0 | Memory address bus. Notes: 1. MemAddr12 is the most significant bit (msb). 2. MemAddr0 is the least significant bit (lsb). | O | 3.3V LVTTTL | |
| BA1:0 | Bank Address supporting up to 4 internal banks. | O | 3.3V LVTTTL | |
| $\overline{\text{RAS}}$ | Row Address Strobe. | O | 3.3V LVTTTL | |
| $\overline{\text{CAS}}$ | Column Address Strobe. | O | 3.3V LVTTTL | |
| DQM0:3 | DQM for byte lane: 0 (MemData0:7), 1 (MemData8:15), 2 (MemData16:23), and 3 (MemData24:31) | O | 3.3V LVTTTL | |
| DQMCB | DQM for ECC check bits. | O | 3.3V LVTTTL | |
| ECC0:7 | ECC check bits 0:7. | I/O | 3.3V LVTTTL | |
| $\overline{\text{BankSel}}0:3$ | Select up to four external SDRAM banks. | O | 3.3V LVTTTL | |
| $\overline{\text{WE}}$ | Write Enable. | O | 3.3V LVTTTL | |
| ClkEn0:1 | SDRAM Clock Enable. | O | 3.3V LVTTTL | |
| MemClkOut0:1 | Two copies of an SDRAM clock allows, in some cases, glueless SDRAM attach without requiring this signal to be repowered by a PLL or zero-delay buffer. | O | 3.3V LVTTTL | |
| External Slave Peripheral Interface | | | | |
| PerData0:31 | Peripheral data bus used by PPC405GPr when not in external master mode, otherwise used by external master. Note: PerData0 is the most significant bit (msb) on this bus. | I/O | 5V tolerant 3.3V LVTTTL | 1 |
| PerAddr0:31 | Peripheral address bus used by PPC405GPr when not in external master mode, otherwise used by external master. Note: PerAddr0 is the most significant bit (msb) on this bus. | I/O | 5V tolerant 3.3V LVTTTL | 1 |
| PerPar0:3 | Peripheral byte parity signals. | I/O | 5V tolerant 3.3V LVTTTL | 1 |
| $\overline{\text{PerWBE}}0:3$ | As outputs, these pins can act as byte-enables which are valid for an entire cycle or as write-byte-enables which are valid for each byte on each data transfer, allowing partial word transactions. As outputs, pins are used by either the peripheral controller or the DMA controller depending upon the type of transfer involved. Used as inputs when an external bus master owns the external interface. | I/O | 5V tolerant 3.3V LVTTTL | 1, 7 |

PowerPC 405GPr Embedded Processor Data Sheet

Signal Functional Description (Part 4 of 8)

Multiplexed signals are shown in brackets following the first signal name assigned to each multiplexed ball.

Notes:

1. Receiver input has hysteresis.
2. Must pull up. See "Pull-Up and Pull-Down Resistors" on page 29 for recommended termination values.
3. Must pull down. See "Pull-Up and Pull-Down Resistors" on page 29 for recommended termination values.
4. If not used, must pull up.
5. If not used, must pull down.
6. Strapping input during reset; pull up or pull down as required.
7. Pull-up may be required. See "External Bus Control Signals" on page 29.

| Signal Name | Description | I/O | Type | Notes |
|---------------------|---|--------|----------------------------|-------|
| [PerWE]PCIINT | Peripheral write enable. Low when any of the four PerWBE0:3 write byte enables are low. or PCI interrupt. Open-drain output (two states; 0 or open circuit) | O | 5V tolerant 3.3V PCI | |
| PerCS0 | Peripheral chip select bank 0. | O | 5V tolerant 3.3V LVTTTL | 7 |
| PerCS1:7[GPIO10:16] | Seven additional peripheral chip selects or General Purpose I/O. To access this function, software must toggle a DCR bit. | O[I/O] | 5V tolerant 3.3V LVTTTL | 1, 7 |
| PerOE | Used by either the peripheral controller or the DMA controller depending upon the type of transfer involved. When the PPC405GPr is the bus master, it enables the selected device to drive the bus. | O | 5V tolerant 3.3V LVTTTL | 7 |
| PerR/W | Used by the PPC405GPr when not in external master mode, as output by either the peripheral controller or DMA controller depending upon the type of transfer involved. High indicates a read from memory, low indicates a write to memory. Otherwise it used by the external master as an input to indicate the direction of data transfer. | I/O | 5V tolerant 3.3V LVTTTL | 1 |
| PerReady | Used by a peripheral slave to indicate it is ready to transfer data. | I | 5V tolerant 3.3V LVTTTL | 1 |
| PerBLast | Used by the PPC405GPr when not in external master mode, otherwise used by external master. Indicates the last transfer of a memory access. | I/O | 5V tolerant 3.3V LVTTTL | 1, 7 |
| DMAReq0:3 | DMAReq0:3 are used by slave peripherals to indicate they are prepared to transfer data. | I | 5V tolerant 3.3V LVTTTL | 1 |
| DMAAck0:3 | DMAAck0:3 are used by the PPC405GPr to cause the DMA peripheral to transfer data. | O | 5V tolerant 3.3V LVTTTL | 6 |
| EOT0:3/TC0:3 | End Of Transfer/Terminal Count. | I/O | 5V tolerant 3.3V LVTTTL | 1 |

PowerPC 405GPr Embedded Processor Data Sheet

Signal Functional Description (Part 5 of 8)

Multiplexed signals are shown in brackets following the first signal name assigned to each multiplexed ball.

Notes:

1. Receiver input has hysteresis.
2. Must pull up. See "Pull-Up and Pull-Down Resistors" on page 29 for recommended termination values.
3. Must pull down. See "Pull-Up and Pull-Down Resistors" on page 29 for recommended termination values.
4. If not used, must pull up.
5. If not used, must pull down.
6. Strapping input during reset; pull up or pull down as required.
7. Pull-up may be required. See "External Bus Control Signals" on page 29.

| Signal Name | Description | I/O | Type | Notes |
|---|--|-----|----------------------------|-------|
| External Master Peripheral Interface | | | | |
| PerClk | Peripheral clock to be used by an external master and by synchronous peripheral slaves. | O | 5V tolerant 3.3V LVTTTL | |
| $\overline{\text{ExtReset}}$ | Peripheral reset to be used by an external master and by synchronous peripheral slaves. | O | 5V tolerant 3.3V LVTTTL | |
| HoldReq | Hold Request, used by an external master to request ownership of the peripheral bus. | I | 5V tolerant 3.3V LVTTTL | 1, 5 |
| HoldAck | Hold Acknowledge, used by the PPC405GPr to transfer ownership of peripheral bus to an external master. | O | 5V tolerant 3.3V LVTTTL | 6 |
| $\overline{\text{ExtReq}}$ | ExtReq is used by an external master to indicate it is prepared to transfer data. | I | 5V tolerant 3.3V LVTTTL | 1 |
| $\overline{\text{ExtAck}}$ | ExtAck is used by the PPC405GPr to indicate a data transfer cycle. | O | 5V tolerant 3.3V LVTTTL | 6 |
| HoldPri | Used by an external master to indicate the priority of a given external master tenure. | I | 5V tolerant 3.3V LVTTTL | 1 |
| BusReq | Used when the PPC405GPr needs to regain control of peripheral interface from an external master. | O | 5V tolerant 3.3V LVTTTL | |
| PerErr | An input used to indicate to the PPC405GPr that an external slave peripheral error occurred. | I | 5V tolerant 3.3V LVTTTL | 1, 5 |
| Internal Peripheral Interface | | | | |
| UARTSerClk | Serial Clock used to provide an alternate clock to the internally generated serial clock. Used in cases where the allowable internally generated baud rates are not satisfactory. This input can be individually connected to either UART. | I | 5V tolerant 3.3V LVTTTL | 1 |
| UART0_Rx | UART0 Serial Data In. | I | 5V tolerant 3.3V LVTTTL | 1 |
| UART0_Tx | UART0 Serial Data Out. | O | 5V tolerant 3.3V LVTTTL | 6 |
| $\overline{\text{UART0_DCD}}$ | UART0 Data Carrier Detect. | I | 5V tolerant 3.3V LVTTTL | 1 |
| $\overline{\text{UART0_DSR}}$ | UART0 Data Set Ready. | I | 5V tolerant 3.3V LVTTTL | 1 |
| $\overline{\text{UART0_CTS}}$ | UART0 Clear To Send. | I | 5V tolerant 3.3V LVTTTL | 1 |
| $\overline{\text{UART0_DTR}}$ | UART0 Data Terminal Ready. | O | 5V tolerant 3.3V LVTTTL | 6 |
| $\overline{\text{UART0_RTS}}$ | UART0 Request To Send. | O | 5V tolerant 3.3V LVTTTL | 6 |
| $\overline{\text{UART0_RI}}$ | UART0 Ring Indicator. | I | 5V tolerant 3.3V LVTTTL | 1 |

PowerPC 405GPr Embedded Processor Data Sheet

Signal Functional Description (Part 6 of 8)

Multiplexed signals are shown in brackets following the first signal name assigned to each multiplexed ball.

Notes:

1. Receiver input has hysteresis.
2. Must pull up. See "Pull-Up and Pull-Down Resistors" on page 29 for recommended termination values.
3. Must pull down. See "Pull-Up and Pull-Down Resistors" on page 29 for recommended termination values.
4. If not used, must pull up.
5. If not used, must pull down.
6. Strapping input during reset; pull up or pull down as required.
7. Pull-up may be required. See "External Bus Control Signals" on page 29.

| Signal Name | Description | I/O | Type | Notes |
|--|--|---------|----------------------------|-------|
| UART1_Rx | UART1 Serial Data In. | I | 5V tolerant 3.3V LVTTTL | 1 |
| UART1_Tx | UART1 Serial Data Out. | O | 5V tolerant 3.3V LVTTTL | 6 |
| $\overline{\text{UART1_DSR}}$ / $\overline{\text{UART1_CTS}}$ | UART1 Data Set Ready or UART1 Clear To Send. To access this function, software must toggle a DCR bit. | I | 5V tolerant 3.3V LVTTTL | 1 |
| $\overline{\text{UART1_RTS}}$ / $\overline{\text{UART1_DTR}}$ | UART1 Request To Send or UART1 Data Terminal Ready. To access this function, software must toggle a DCR bit. | O | 5V tolerant 3.3V LVTTTL | 6 |
| IIC_SCL | IIC Serial Clock. | I/O | 5V tolerant 3.3V LVTTTL | 1, 2 |
| IIC_SDA | IIC Serial Data. | I/O | 5V tolerant 3.3V LVTTTL | 1, 2 |
| Interrupts Interface | | | | |
| IRQ0:6[GPIO17:23] | Interrupt requests or General Purpose I/O. To access this function, software must toggle a DCR bit. | I/[I/O] | 5V tolerant 3.3V LVTTTL | 1 |
| JTAG Interface | | | | |
| TDI | Test data in. | I | 5V tolerant 3.3V LVTTTL | 1, 4 |
| TMS | JTAG test mode select. | I | 5V tolerant 3.3V LVTTTL | 1, 4 |
| TDO | Test data out. | O | 5V tolerant 3.3V LVTTTL | |
| TCK | JTAG test clock. The frequency of this input can range from DC to 25MHz. | I | 5V tolerant 3.3V LVTTTL | 1, 4 |
| $\overline{\text{TRST}}$ | JTAG reset. $\overline{\text{TRST}}$ must be low at power-on to initialize the JTAG controller and for normal operation of the PPC405GPr. | I | 5V tolerant 3.3V LVTTTL | 5 |
| System Interface | | | | |
| SysClk | Main system clock input. | I | 5V tolerant 3.3V LVTTTL | |
| $\overline{\text{SysReset}}$ | Main system reset. External logic can drive this bidirectional pin low (minimum of 16 cycles) to initiate a system reset. A system reset can also be initiated by software. Implemented as an open-drain output (two states; 0 or open circuit). | I/O | 5V tolerant 3.3V LVTTTL | 1, 2 |
| AV _{DD} | Clean voltage input for the PLL. | I | | |

PowerPC 405GPr Embedded Processor Data Sheet

Signal Functional Description (Part 7 of 8)

Multiplexed signals are shown in brackets following the first signal name assigned to each multiplexed ball.

Notes:

1. Receiver input has hysteresis.
2. Must pull up. See "Pull-Up and Pull-Down Resistors" on page 29 for recommended termination values.
3. Must pull down. See "Pull-Up and Pull-Down Resistors" on page 29 for recommended termination values.
4. If not used, must pull up.
5. If not used, must pull down.
6. Strapping input during reset; pull up or pull down as required.
7. Pull-up may be required. See "External Bus Control Signals" on page 29.

| Signal Name | Description | I/O | Type | Notes |
|----------------------------|---|--------|----------------------------|-------|
| AGND | Clean Ground input for the PLL. | I | | |
| SysErr | Set to 1 when a Machine Check is generated. | O | 5V tolerant 3.3V LVTTTL | |
| $\overline{\text{Halt}}$ | Halt from external debugger. | I | 5V tolerant 3.3V LVTTTL | 1, 2 |
| GPIO1[TS1E] GPIO2[TS2E] | General Purpose I/O or Even Trace execution status. To access this function, software must toggle a DCR bit. | I/O[O] | 5V tolerant 3.3V LVTTTL | 1, 6 |
| GPIO3[TS1O] | General Purpose I/O or Odd Trace execution status. To access this function, software must toggle a DCR bit. | I/O[O] | 5V tolerant 3.3V LVTTTL | 1, 6 |
| GPIO4[TS2O] | General Purpose I/O or Odd Trace execution status. To access this function, software must toggle a DCR bit. | I/O[O] | 5V tolerant 3.3V LVTTTL | 1, 6 |
| GPIO5:8[TS3:6] | General Purpose I/O or Trace status. To access this function, software must toggle a DCR bit. | I/O[O] | 5V tolerant 3.3V LVTTTL | 1, 6 |
| GPIO9[TrcClk] | General Purpose I/O or Trace interface clock. A toggling signal that is always half of the CPU core frequency. To access this function, software must toggle a DCR bit. Note: Initialization strapping must hold this pin low (0) during reset. | I/O[O] | 5V tolerant 3.3V LVTTTL | 1, 6 |
| GPIO24 | General Purpose I/O. Note: The pull-up initialization strapping resistor must be 1 k Ω rather than 3 k Ω in order to overcome the internal pull-down resistor. | I/O | 3.3V LVTTTL w/pull-down | 1, 6 |
| $\overline{\text{TestEn}}$ | Test Enable. Used only for manufacturing tests. Pull down for normal operation. | I | 1.8V CMOS w/pull-down | |
| TmrClk | An external clock input that can be used to clock the timers in the CPU core. | I | 5V tolerant 3.3V LVTTTL | 1 |
| Trace Interface | | | | |
| [TS1E]GPIO1 [TS2E]GPIO2 | Even Trace execution status. To access this function, software must toggle a DCR bit or General Purpose I/O. | O[I/O] | 5V tolerant 3.3V LVTTTL | 1, 6 |

PowerPC 405GPr Embedded Processor Data Sheet

Signal Functional Description (Part 8 of 8)

Multiplexed signals are shown in brackets following the first signal name assigned to each multiplexed ball.

Notes:

1. Receiver input has hysteresis.
2. Must pull up. See “Pull-Up and Pull-Down Resistors” on page 29 for recommended termination values.
3. Must pull down. See “Pull-Up and Pull-Down Resistors” on page 29 for recommended termination values.
4. If not used, must pull up.
5. If not used, must pull down.
6. Strapping input during reset; pull up or pull down as required.
7. Pull-up may be required. See “External Bus Control Signals” on page 29.

| Signal Name | Description | I/O | Type | Notes |
|-----------------------------|---|--------|----------------------------|-------|
| [TS1O]GPIO3 | Odd Trace execution status. To access this function, software must toggle a DCR bit or General Purpose I/O. | O[I/O] | 5V tolerant 3.3V LVTTTL | 1, 6 |
| [TS2O]GPIO4 | Odd Trace execution status. To access this function, software must toggle a DCR bit or General Purpose I/O. | O[I/O] | 5V tolerant 3.3V LVTTTL | 1, 6 |
| [TS3:6]GPIO5:8 | Trace status. To access this function, software must toggle a DCR bit or General Purpose I/O. | O[I/O] | 5V tolerant 3.3V LVTTTL | 1, 6 |
| [TrcClk]GPIO9 | Trace interface clock. A toggling signal that is always half of the CPU core frequency. To access this function, software must toggle a DCR bit or General Purpose I/O. Note: Initialization strapping must hold this pin low (0) during reset. | O[I/O] | 5V tolerant 3.3V LVTTTL | 1, 6 |
| Ground pins | | | | |
| GND | Ground Note: L11-L16, M11-M16, N11-N16, P11-P16, R11-R16, and T11-T16 are also thermal balls. | | | |
| OV_{DD} pins | | | | |
| OV _{DD} | Output driver voltage—3.3V. | | | |
| V_{DD} pins | | | | |
| V _{DD} | Logic voltage—1.8V. | | | |
| Other pins | | | | |
| Reserved | Reserved—Except for AF4, do not connect signals, voltage, or ground to these pins. AF4 must be tied to OV _{DD} or GND. | | | |

PowerPC 405GPr Embedded Processor Data Sheet

Absolute Maximum Ratings

The absolute maximum ratings below are stress ratings only. Operation at or beyond these maximum ratings can cause permanent damage to the device.

| Characteristic | Symbol | Value | Unit |
|---------------------------------------|-----------|-------------------------|------|
| Supply Voltage (Internal Logic) | V_{DD} | 0 to +1.95 | V |
| Supply Voltage (I/O Interface) | OV_{DD} | 0 to +3.6 | V |
| PLL Supply Voltage | AV_{DD} | 0 to +1.95 | V |
| Input Voltage (1.8V CMOS receivers) | V_{IN} | -0.6 to $V_{DD} + 0.45$ | V |
| Input Voltage (3.3V LVTTTL receivers) | V_{IN} | -0.6 to $OV_{DD} + 0.6$ | V |
| Input Voltage (5.0V LVTTTL receivers) | V_{IN} | -0.6 to $OV_{DD} + 2.4$ | V |
| Storage Temperature Range | T_{STG} | -55 to +150 | °C |
| Case temperature under bias | T_C | -40 to +120 | °C |

Note: All specified voltages are with respect to GND.

Package Thermal Specifications

The PPC405GPr is designed to operate within a case temperature range of -40°C to +85°C. Thermal resistance values for the E-PBGA packages in a convection environment are as follows:

| Package—Thermal Resistance | Symbol | Airflow ft/min (m/sec) | | | Unit |
|---|---------------|---------------------------|------------|------------|------|
| | | 0 (0) | 100 (0.51) | 200 (1.02) | |
| 35 mm, 456-balls—Junction-to-Case | θ_{JC} | 2 | 2 | 2 | °C/W |
| 35 mm, 456-balls—Case-to-Ambient ¹ | θ_{CA} | 14 | 13 | 12 | °C/W |
| 27 mm, 456-balls—Junction-to-Case | θ_{JC} | 2 | 2 | 2 | °C/W |
| 27 mm, 456-balls—Case-to-Ambient ¹ | θ_{CA} | 18 | 16 | 15 | °C/W |

Note:

1. For a chip mounted on a JEDEC 2S2P card without a heat sink.
2. For a chip mounted on a card with at least one signal and two power planes, the following relationships exist:
 - a. Case temperature, T_C , is measured at top center of case surface with device soldered to circuit board.
 - b. $T_A = T_C - P \times \theta_{CA}$, where T_A is ambient temperature and P is power consumption.
 - c. $T_{CMax} = T_{JMax} - P \times \theta_{JC}$, where T_{JMax} is maximum junction temperature and P is power consumption.

PowerPC 405GPr Embedded Processor Data Sheet

Recommended DC Operating Conditions

Device operation beyond the conditions specified is not recommended. Extended operation beyond the recommended conditions can affect device reliability.

Notes:

1. PCI drivers meet PCI specifications.

| Parameter | Symbol | Minimum | Typical | Maximum | Unit | Notes |
|---|---------------|-----------------|---------|-------------------|-------------|-------|
| Logic Supply Voltage | V_{DD} | 1.7 | 1.8 | 1.9 | V | |
| I/O Supply Voltage | OV_{DD} | 3.0 | 3.3 | 3.6 | V | |
| PLL Supply Voltage | AV_{DD} | 1.7 | 1.8 | 1.9 | V | |
| Input Logic High (1.8V CMOS receivers) | V_{IH} | $0.65V_{DD}$ | | V_{DD} | V | |
| Input Logic High (3.3V LVTTTL receivers) | V_{IH} | 2.0 | | OV_{DD} | V | |
| Input Logic High (5.0V LVTTTL receivers) | V_{IH} | 2.0 | | 5.5 | V | |
| Input Logic Low (1.8V CMOS receivers) | V_{IL} | 0 | | $0.65V_{DD}$ | V | |
| Input Logic Low (3.3/5.0V LVTTTL receivers) | V_{IL} | 0 | | 0.8 | V | |
| Output Logic High | V_{OH} | 2.4 | | OV_{DD} | V | |
| Output Logic Low | V_{OL} | 0 | | 0.4 | V | |
| 3.3V I/O Input Current (no pull-up or pull-down) | I_{IL1} | | | ± 10 | μA | |
| Input Current (with internal pull-down) | I_{IL2} | ± 10 (@ 0V) | | 200 (@ V_{DD}) | μA | |
| 5V Tolerant I/O Input Current ¹ | I_{IL4} | ± 10 | | -325 | μA | |
| Input Max Allowable Overshoot (1.8V CMOS receivers) | $V_{IMAO1.8}$ | | | $V_{DD} + 0.6$ | V | |
| Input Max Allowable Overshoot (3.3V LVTTTL receivers) | V_{IMAO3} | | | $OV_{DD} + 0.6$ | V | |
| Input Max Allowable Overshoot (5.0V LVTTTL receivers) | V_{IMAO5} | | | 5.5 | V | |
| Input Max Allowable Undershoot | V_{IMAU} | -0.6 | | | V | |
| Output Max Allowable Overshoot | V_{OMAO} | | | $OV_{DD} + 0.3$ | V | |
| Output Max Allowable Undershoot | V_{OMAU3} | -0.6 | | | V | |
| Case Temperature | T_C | -40 | | +85 | $^{\circ}C$ | |

Notes:

1. See "5V-Tolerant Input Current" on page 40

PowerPC 405GPr Embedded Processor Data Sheet

5V-Tolerant Input Current

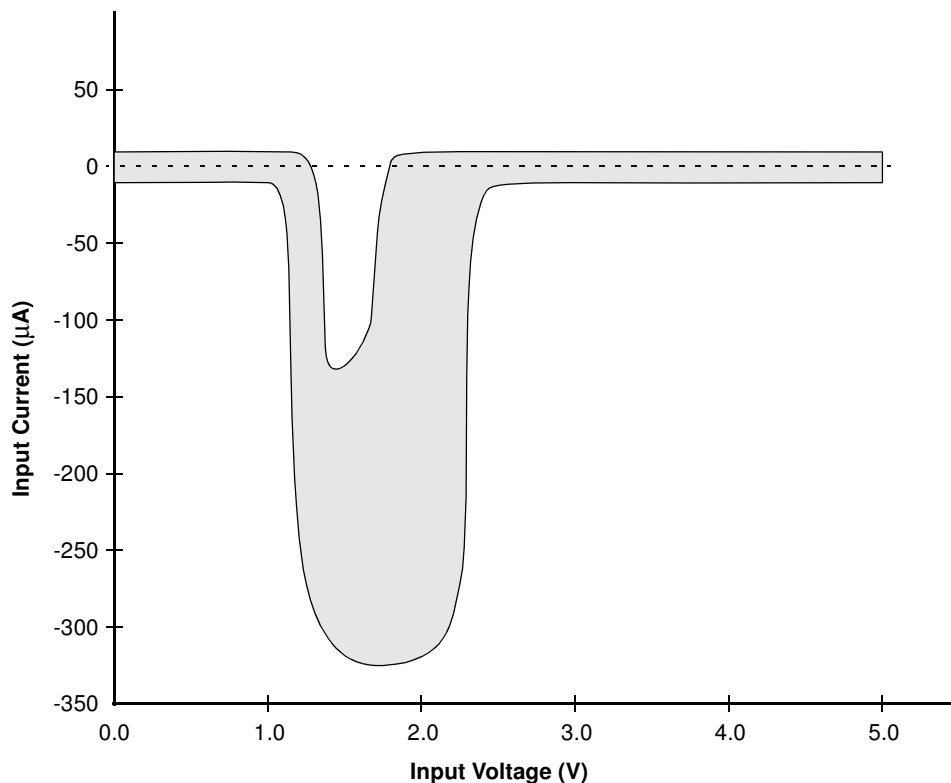

Input Capacitance

| Parameter | Symbol | Maximum | Unit | Notes |
|------------------------|-----------|---------|------|-------|
| 3.3V LVTTTL I/O | C_{IN1} | 8.8 | pF | |
| 5V tolerant LVTTTL I/O | C_{IN2} | 8 | pF | |
| PCI I/O | C_{IN3} | 9.3 | pF | |
| Rx only pins | C_{IN4} | 4.5 | pF | |

PowerPC 405GPr Embedded Processor Data Sheet

DC Electrical Characteristics

| Parameter | Symbol | Minimum | Typical | Maximum | Unit |
|--|-----------|---------|---------|---------|------|
| Active Operating Current (V_{DD})–266MHz | I_{DD} | | 300 | 610 | mA |
| Active Operating Current (V_{DD})–333MHz | I_{DD} | | 325 | 690 | mA |
| Active Operating Current (V_{DD})–400MHz | I_{DD} | | 355 | 770 | mA |
| Active Operating Current (OV_{DD}) | I_{ODD} | | 45 | 200 | mA |
| PLL V_{DD} Input current | I_{PLL} | | 16 | 23 | mA |
| Active Operating Power–266 MHz | P_{DD} | | 0.72 | 1.92 | W |
| Active Operating Power–333MHz | P_{DD} | | 0.76 | 2.07 | W |
| Active Operating Power–400MHz | P_{DD} | | 0.82 | 2.23 | W |

Note:

- The maximum current and power values listed above are not guaranteed to be the highest obtainable. These values are dependent on many factors including the type of applications running, clock rates, use of internal functional capabilities, external interface usage, case temperature, and the power supply voltages. Your specific application can produce significantly different results. V_{DD} (logic) current and power are primarily dependent on the applications running and the use of internal chip functions (DMA, PCI, Ethernet, and so on). OV_{DD} (I/O) current and power are primarily dependent on the capacitive loading, frequency, and utilization of the external buses. The following information provides details about the conditions under which the listed values were obtained:
 - In general, the values were measured using a PPC405GPr Evaluation Board with four PCI devices, an external bus master on the peripheral bus, and external wrap-back on the Ethernet port. For all CPU clock rates, PLB = 133.3MHz, OPB = PerClk = 66.6MHz, PCI = SysClk = 33.3MHz.
 - Typical current and power are characterized at $V_{DD} = +1.8V$, $OV_{DD} = +3.3V$, and $T_C = +36^\circ C$ while running various applications under the Linux operating system.
 - Maximum current and power are characterized at $V_{DD} = +1.9V$, $OV_{DD} = +3.6V$, and $T_C = +85^\circ C$ while running applications designed to maximize CPU power consumption. An external PCI master heavily loads the PCI bus with transfers targeting SDRAM while the internal DMA controller further increases SDRAM bus traffic.
- AV_{DD} should be derived from V_{DD} using the following circuit:

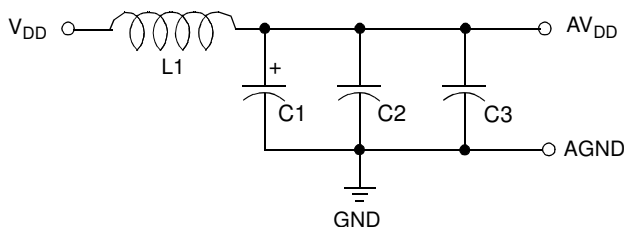

- L1 – 2.2µH SMT inductor (equivalent to MuRata LQH3C2R2M34) or SMT chip ferrite bead (equivalent to MuRata BLM31A700S)
- C1 – 3.3 µF SMT tantalum
- C2 – 0.1 µF SMT monolithic ceramic capacitor with X7R dielectric or equivalent
- C3 – 0.01 µF SMT monolithic ceramic capacitor with X7R dielectric or equivalent

PowerPC 405GPr Embedded Processor Data Sheet

Test Conditions

Clock timing and switching characteristics are specified in accordance with operating conditions shown in the table "Recommended DC Operating Conditions." For all signals other than PCI signals, AC specifications are characterized at $OV_{DD} = +3V$ and $T_C = +85^\circ C$ with the 50pF test load shown in the figure at right.

For PCI signals there are two different test load circuits, one for the rising edge and one the falling edge as shown in the figures at right.

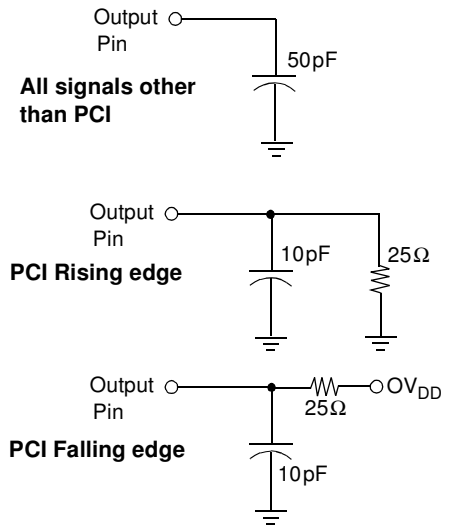

PowerPC 405GPr Embedded Processor Data Sheet

Clocking Specifications

| Symbol | Parameter | Min | Max | Units |
|---|---|-----------------------|-------------------------|-------|
| CPU | | | | |
| PF_C | Processor clock frequency | | 266.66 or 333.33 or 400 | MHz |
| PT_C | Processor clock period | 3.75 or 3.00 or 2.5 | | ns |
| SysClk Input | | | | |
| SCF_C | Clock input frequency | 25 | 66.66 | MHz |
| SCT_C | Clock period | 15 | 40 | ns |
| SCT_{CS} | Clock edge stability (phase jitter, cycle to cycle) | | ± 0.15 | ns |
| SCT_{CH} | Clock input high time | 40% of nominal period | 60% of nominal period | ns |
| SCT_{CL} | Clock input low time | 40% of nominal period | 60% of nominal period | ns |
| Note: Input slew rate > 1 V/ns between 0.8V and 2.0V | | | | |
| MemClkOut Output | | | | |
| $MCOF_C$ | Clock output frequency @ $PF_C = 266\text{MHz}$ | | 133.33 | MHz |
| $MCOT_C$ | Clock period @ $PF_C = 266\text{MHz}$ | 7.5 | | ns |
| $MCOT_{CS}$ | Clock edge stability (phase jitter, cycle to cycle) | | ± 0.2 | ns |
| $MCOT_{CH}$ | Clock output high time | 45% of nominal period | 55% of nominal period | ns |
| $MCOT_{CL}$ | Clock output low time | 45% of nominal period | 55% of nominal period | ns |
| TrcClk Output | | | | |
| TCF_C | Clock output frequency | | $PF_C / 2$ | MHz |
| TCT_C | Clock period | | $PT_C \times 2$ | ns |
| TCT_{CS} | Clock edge stability (phase jitter, cycle to cycle) | | ± 0.2 | ns |
| TCT_{CH} | Clock output high time | 45% of nominal period | 55% of nominal period | ns |
| TCT_{CL} | Clock output low time | 45% of nominal period | 55% of nominal period | ns |
| Other Clocks | | | | |
| $VCOF_C$ | VCO frequency @ $PF_C = 266\text{MHz}$ | 500 | 1000 | MHz |
| $VCOF_C$ | VCO frequency @ $PF_C = 333\text{MHz}$ or 400MHz | 500 | 1333 | MHz |
| $PLBF_C$ | PLB frequency | | 133.33 | MHz |
| $OPBF_C$ | OPB frequency | | 66.66 | MHz |

Clocking Waveform

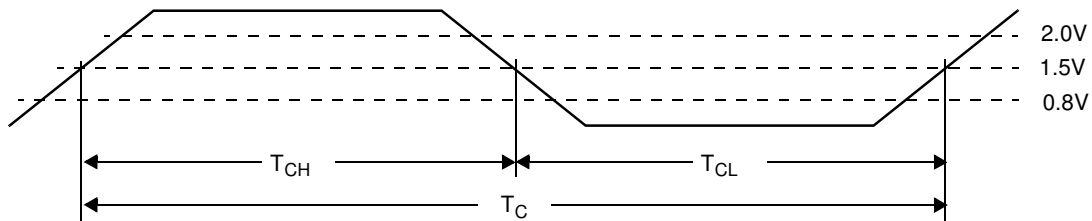

PowerPC 405GPr Embedded Processor Data Sheet

Spread Spectrum Clocking

Care must be taken when using a spread spectrum clock generator (SSCG) with the PPC405GPr. This controller uses a PLL for clock generation inside the chip. The accuracy with which the PLL follows the SSCG is referred to as tracking skew. The PLL bandwidth and phase angle determine how much tracking skew there is between the SSCG and the PLL for a given frequency deviation and modulation frequency. When using an SSCG with the PPC405GPr the following conditions must be met:

- The frequency deviation must not violate the minimum clock cycle time. Therefore, when operating the PPC405GPr with one or more internal clocks at their maximum supported frequency, the SSCG can only lower the frequency.
- The maximum frequency deviation cannot exceed -3% , and the modulation frequency cannot exceed 40kHz. In some cases, on-board PPC405GPr peripherals impose more stringent requirements (see Note 1).
- Use the peripheral bus clock (PerClk) for logic that is synchronous to the peripheral bus since this clock tracks the modulation.
- Use the SDRAM MemClkOut since it also tracks the modulation.

Notes:

1. The serial port baud rates are synchronous to the modulated clock. The serial port has a tolerance of approximately 1.5% on baud rate before framing errors begin to occur. The 1.5% tolerance assumes that the connected device is running at precise baud rates. If an external serial clock is used the baud rate is unaffected by the modulation.
2. Operation of the PPC405GPr PCI Bridge is unaffected by the use of a SSCG.

For PCI frequencies of 33.33 MHz and below the PCI controller supports synchronous mode operation. This is accomplished by strapping the PPC405GPr for synchronous mode PCI and connecting the PCI bus clock to the PPC405GPr SysClk input. For 33.33 MHz signalling, the PCI specification has no limitation on the amount of frequency deviation or modulation that may be applied to the PCI clock. Therefore, the PPC405GPr SSCG requirements stated above take precedence.

At PCI frequencies above 33.33 MHz, the PCI controller must be operated in asynchronous mode. When in asynchronous mode, the PCI bus clock must be driven into the PPC405GPr PCIClk input. In this configuration the PCI controller supports the 66.66 MHz PCI clock specification which specifies a maximum frequency deviation of -1% at a modulation of between 30 kHz and 33 kHz.

3. Ethernet operation is unaffected.
4. IIC operation is unaffected.

Caution: It is up to the system designer to ensure that any SSCG used with the PPC405GPr meets the above requirements and does not adversely affect other aspects of the system.

PowerPC 405GPr Embedded Processor Data Sheet

Peripheral Interface Clock Timings

| Parameter | Min | Max | Units |
|--|-----------------------|-----------------------|-------|
| PCIClk input frequency (asynchronous mode) | Note 1 | 66.66 | MHz |
| PCIClk period (asynchronous mode) | 15 | Note 1 | ns |
| PCI Clock frequency (synchronous mode) | 25 | 33.33 | MHz |
| PCI Clock period (synchronous mode - Note 2) | 30 | 40 | ns |
| PCIClk input high time | 40% of nominal period | 60% of nominal period | ns |
| PCIClk input low time | 40% of nominal period | 60% of nominal period | ns |
| EMCMDClk output frequency | – | 2.5 | MHz |
| EMCMDClk period | 400 | – | ns |
| EMCMDClk output high time | 160 | – | ns |
| EMCMDClk output low time | 160 | – | ns |
| PHYTxClk input frequency | 2.5 | 25 | MHz |
| PHYTxClk period | 40 | 400 | ns |
| PHYTxClk input high time | 35% of nominal period | – | ns |
| PHYTxClk input low time | 35% of nominal period | – | ns |
| PHYRxClk input frequency | 2.5 | 25 | MHz |
| PHYRxClk period | 40 | 400 | ns |
| PHYRxClk input high time | 35% of nominal period | – | ns |
| PHYRxClk input low time | 35% of nominal period | – | ns |
| PerClk output frequency | – | 66.66 | MHz |
| PerClk period | 15 | – | ns |
| PerClk output high time | 45% of nominal period | 55% of nominal period | ns |
| PerClk output low time | 45% of nominal period | 55% of nominal period | ns |
| PerClk clock edge stability (phase jitter, cycle to cycle) | | ± 0.3 | ns |
| UARTSerClk input frequency (Note 3) | – | $1000/(2T_{OPB}+2ns)$ | MHz |
| UARTSerClk period | $2T_{OPB}+2$ | – | ns |
| UARTSerClk input high time | $T_{OPB}+1$ | – | ns |
| UARTSerClk input low time | $T_{OPB}+1$ | – | ns |
| TmrClk input frequency | – | 66.66 | MHz |
| TmrClk period | 15 | – | ns |
| TmrClk input high time | 40% of nominal period | 60% of nominal period | ns |
| TmrClk input low time | 40% of nominal period | 60% of nominal period | ns |

Note:

1. In asynchronous PCI mode the minimum PCIClk frequency is 1/8 the PLB Clock. Refer to the *PowerPC 405GPr Embedded Processor User's Manual* for more information.
2. In synchronous PCI mode the PCI clock is derived from SysClk and the PCIClk input pin is unused.
3. T_{OPB} is the period in ns of the OPB clock. The maximum OPB clock frequency is 66.66MHz.

PowerPC 405GPr Embedded Processor Data Sheet

Input Setup and Hold Waveform

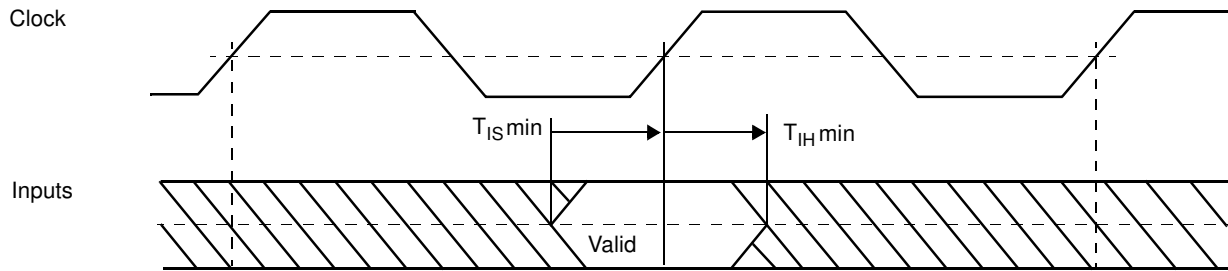

Output Delay and Float Timing Waveform

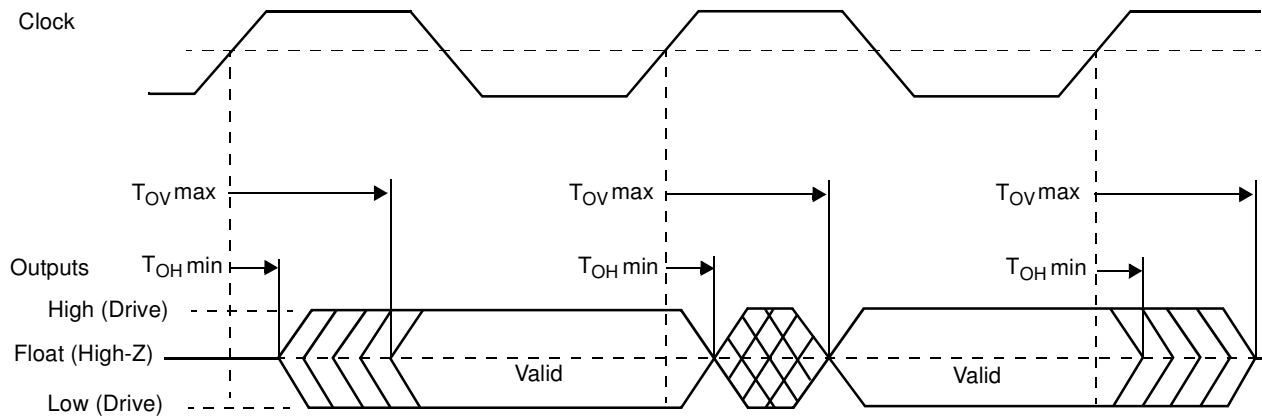



PowerPC 405GPr Embedded Processor Data Sheet

- Notes:** 1. In all of the following I/O Specifications tables a timing values of na means “not applicable” and dc means “don’t care.”
 2. See “Test Conditions” on page 42 for output capacitive loading.

I/O Specifications—Group 1 (Part 1 of 3)

Notes:

1. PCI timings are for operation up to 66.66MHz. PCI output hold time requirement is 1 ns for 66.66MHz and 2ns for 33.33MHz. In synchronous mode, timing is relative to SysClk. In asynchronous mode, timing is relative to PCIClk.
2. Ethernet interface meets timing requirements as defined by IEEE 802.3 standard.
3. For PCI, I/O H is specified at 0.9OV_{DD} and I/O L is specified at 0.1OV_{DD}. For all other interfaces, I/O H is specified at 2.4 V and I/O L is specified at 0.4 V.

| Signal | Input (ns) | | Output (ns) | | Output Current (mA) | | Clock | Notes |
|---------------------------|----------------------------------|---------------------------------|-----------------------------------|---------------------------------|---------------------|-------------|-----------|----------|
| | Setup Time (T _{IS} min) | Hold Time (T _{IH} min) | Valid Delay (T _{OV} max) | Hold Time (T _{OH} min) | I/O H (min) | I/O L (min) | | |
| PCI Interface | | | | | | | | |
| PCIID31:0 | 3 | 0 | 6 | 1 | 0.5 | 1.5 | PCI Clock | 1 |
| PCIC3:0[BE3:0] | 3 | 0 | 6 | 1 | 0.5 | 1.5 | PCI Clock | 1 |
| PCIClk | dc | dc | na | na | na | na | | async |
| PCIDevSel | 3 | 0 | 6 | 1 | 0.5 | 1.5 | PCI Clock | 1 |
| PCIFrame | 3 | 0 | 6 | 1 | 0.5 | 1.5 | PCI Clock | 1 |
| PCIGnt0[Req] PCIGnt1:5 | na | na | na | na | 0.5 | 1.5 | PCI Clock | 1 |
| PCIIDSel | 3 | 0 | 6 | 1 | na | na | PCI Clock | 1 |
| PCIINT[PerWE] | na | na | dc | dc | 0.5 | 1.5 | PCI Clock | async |
| PCIIRDY | 3 | 0 | 6 | 1 | 0.5 | 1.5 | PCI Clock | 1 |
| PCIParity | 3 | 0 | 6 | 1 | 0.5 | 1.5 | PCI Clock | 1 |
| PCIPErr | 3 | 0 | 6 | 1 | 0.5 | 1.5 | PCI Clock | 1 |
| PCIREq0[Gnt] PCIREq1:5 | 5 | 0 | na | na | na | na | PCI Clock | 1 |
| PCIReset | na | na | na | na | 0.5 | 1.5 | PCI Clock | |
| PCISerr | na | na | na | na | 0.5 | 1.5 | PCI Clock | |
| PCIStop | 3 | 0 | 6 | 1 | 0.5 | 1.5 | PCI Clock | 1 |
| PCITRDY | 3 | 0 | 6 | 1 | 0.5 | 1.5 | PCI Clock | 1 |
| Ethernet Interface | | | | | | | | |
| EMCMDClk | na | na | settable | 2 | 10.3 | 7.1 | | 2, async |
| EMCMDIO[PHYMDIO] | 100 | 0 | 1 OPB clock period + 10ns | 1 OPB clock period | 10.3 | 7.1 | EMCMDClk | 2 |
| EMCTxD3:0 | na | na | 20 | 2 | 10.3 | 7.1 | PHYTX | 2 |
| EMCTxEn | na | na | 20 | 2 | 10.3 | 7.1 | PHYTX | 2 |
| EMCTxErr | na | na | 20 | 2 | 10.3 | 7.1 | PHYTX | 2 |
| PHYCol | | | | | 10.3 | 7.1 | | 2, async |
| PHYCrS | | | | | 10.3 | 7.1 | | 2, async |
| PHYRxCIk | | | | | na | na | | 2, async |
| PHYRxD3:0 | 4 | 1 | na | na | 10.3 | 7.1 | PHYRX | 2 |
| PHYRxDV | 4 | 1 | na | na | 10.3 | 7.1 | PHYRX | 2 |
| PHYRxErr | 4 | 1 | na | na | 10.3 | 7.1 | PHYRX | 2 |
| PHYTxClk | | | | | na | na | | 2, async |

PowerPC 405GPr Embedded Processor Data Sheet

I/O Specifications—Group 1 (Part 2 of 3)

Notes:

1. PCI timings are for operation up to 66.66MHz. PCI output hold time requirement is 1 ns for 66.66MHz and 2ns for 33.33MHz. In synchronous mode, timing is relative to SysClk. In asynchronous mode, timing is relative to PCIClk.
2. Ethernet interface meets timing requirements as defined by IEEE 802.3 standard.
3. For PCI, I/O H is specified at $0.90V_{DD}$ and I/O L is specified at $0.10V_{DD}$. For all other interfaces, I/O H is specified at 2.4 V and I/O L is specified at 0.4 V.

| Signal | Input (ns) | | Output (ns) | | Output Current (mA) | | Clock | Notes |
|---|-------------------------------|------------------------------|--------------------------------|------------------------------|---------------------|----------------|-------|-------|
| | Setup Time (T_{IS} min) | Hold Time (T_{IH} min) | Valid Delay (T_{OV} max) | Hold Time (T_{OH} min) | I/O H (min) | I/O L (min) | | |
| Internal Peripheral Interface | | | | | | | | |
| IIC_SCL | na | na | na | na | 15.3 | 10.2 | | |
| IIC_SDA | na | na | na | na | 15.3 | 10.2 | | |
| UART0_CTS | na | na | | | 10.3 | 7.1 | | |
| UART0_DCD | na | na | | | 10.3 | 7.1 | | |
| UART0_DSR | na | na | | | 10.3 | 7.1 | | |
| UART0_DTR | | | | | 10.3 | 7.1 | | |
| UART0_RI | na | na | | | 10.3 | 7.1 | | |
| UART0_RTS | | | na | na | 10.3 | 7.1 | | |
| UART0_Rx | na | na | | | 10.3 | 7.1 | | |
| UART0_Tx | | | na | na | 10.3 | 7.1 | | |
| UART1_RTS/ UART1_DTR | | | na | na | 10.3 | 7.1 | | |
| UART1_DSR/ UART1_CTS | na | na | | | na | na | | |
| UART1_Rx | na | na | | | na | na | | |
| UART1_Tx | | | na | na | 10.3 | 7.1 | | |
| UARTSerClk | na | na | | | na | na | | |
| Interrupts Interface | | | | | | | | |
| IRQ0:6[GPIO17:23] | | | | | 10.3 | 7.1 | | |
| JTAG Interface | | | | | | | | |
| TCK | | | | | na | na | | async |
| TDI | | | | | na | na | | async |
| TDO | | | | | 10.3 | 7.1 | | async |
| TMS | | | | | na | na | | async |
| TRST | | | | | na | na | | async |
| System Interface | | | | | | | | |
| GPIO1 GPIO2 GPIO3 GPIO4 GPIO5 GPIO6 GPIO7 GPIO8 GPIO9 GPIO24 | | | | | 10.3 | 7.1 | | |
| Halt | dc | dc | na | na | na | na | | async |
| SysClk | | | na | na | na | na | | |
| SysErr | | | na | na | 10.3 | 7.1 | | async |
| SysReset | | | 10 | 1 | 10.3 | 7.1 | | async |
| TestEn | dc | dc | na | na | na | na | | async |
| TmrClk | dc | dc | na | na | na | na | | async |



PowerPC 405GPr Embedded Processor Data Sheet

I/O Specifications—Group 1 (Part 3 of 3)

Notes:

1. PCI timings are for operation up to 66.66MHz. PCI output hold time requirement is 1 ns for 66.66MHz and 2ns for 33.33MHz. In synchronous mode, timing is relative to SysClk. In asynchronous mode, timing is relative to PCIClk.
2. Ethernet interface meets timing requirements as defined by IEEE 802.3 standard.
3. For PCI, I/O H is specified at 0.9OV_{DD} and I/O L is specified at 0.1OV_{DD}. For all other interfaces, I/O H is specified at 2.4 V and I/O L is specified at 0.4 V.

| Signal | Input (ns) | | Output (ns) | | Output Current (mA) | | Clock | Notes |
|--|----------------------------------|---------------------------------|-----------------------------------|---------------------------------|---------------------|-------------|--------|-----------------------|
| | Setup Time (T _{IS} min) | Hold Time (T _{IH} min) | Valid Delay (T _{OV} max) | Hold Time (T _{OH} min) | I/O H (min) | I/O L (min) | | |
| Trace | | | | | | | | |
| [TS1E] [TS2E] [TS1O] [TS2O] [TS3] [TS4] [TS5] [TS6] | na | na | PT _C /2+0.7 | PT _C /2-0.5 | 10.3 | 7.1 | TrcClk | 10pF load on clk/data |

PowerPC 405GPr Embedded Processor Data Sheet

I/O Specifications—Group 2 (Part 1 of 2)

Notes:

1. The SDRAM command interface is configurable through SDRAM0_TR[LDF] to provide a 2 to 4 cycle delay before the command is used by SDRAM.
2. SDRAM I/O timings are specified relative to a MemClkOut terminated into a lumped 10pF load.
3. SDRAM interface hold times are guaranteed at the PPC405GPr package pin. System designers must use the PPC405GPr IBIS model (available from www.chips.ibm.com) to ensure their clock distribution topology minimizes loading and reflections, and that the relative delays on clock wiring do not exceed the delays on other SDRAM signal wiring.
4. PerClk timing is specified with a 10pF load at the package pin. The indicated timing is valid only if PerClk feedback is selected. Refer to the *PowerPC 405GPr Embedded Processor User's Manual* for more information.
5. Input timings are specified at 1.5V, assuming transition times between 1 and 2ns, when measured between the 10% and 90% points of the output voltage.
6. I/O H is specified at 2.4 V and I/O L is specified at 0.4 V.

| Signal | Input (ns) | | Output (ns) | | Output Current (mA) | | Clock | Notes |
|--|----------------------------------|---------------------------------|-----------------------------------|---------------------------------|---------------------|-----------------|-----------|---------|
| | Setup Time (T _{IS} min) | Hold Time (T _{IH} min) | Valid Delay (T _{OV} max) | Hold Time (T _{OH} min) | I/O H (minimum) | I/O L (minimum) | | |
| SDRAM Interface | | | | | | | | |
| BA1:0 | na | na | 4.5 | 1.6 | 15.3 | 10.2 | MemClkOut | 1, 2, 5 |
| BankSel3:0 | na | na | 4.5 | 1.5 | 15.3 | 10.2 | MemClkOut | 2, 5 |
| CAS | na | na | 4.4 | 1.5 | 15.3 | 10.2 | MemClkOut | 1, 2, 5 |
| ClkEn0:1 | na | na | 3.9 | 1.4 | 23 | 19.3 | MemClkOut | 2, 5 |
| DQM0:3 | na | na | 4.5 | 1.4 | 15.3 | 10.2 | MemClkOut | 2, 5 |
| DQMCB | na | na | 4.3 | 1.4 | 15.3 | 10.2 | MemClkOut | 2, 5 |
| ECC0:7 | 1.4 | 0 | 4.5 | 1.5 | 15.3 | 10.2 | MemClkOut | 2, 5 |
| MemAddr12:0 | na | na | 4.6 | 1.5 | 15.3 | 10.2 | MemClkOut | 1, 2, 5 |
| MemData0:31 | 1.4 | 0 | 5.1 | 1.4 | 15.3 | 10.2 | MemClkOut | 2, 5 |
| RAS | na | na | 4.4 | 1.5 | 15.3 | 10.2 | MemClkOut | 1, 2, 5 |
| WE | na | na | 4.4 | 1.5 | 15.3 | 10.2 | MemClkOut | 1, 2, 5 |
| External Slave Peripheral Interface | | | | | | | | |
| DMAAck0:3 | na | na | 6.1 | 2.2 | 10.3 | 7.1 | PerClk | 5 |
| DMAReq0:3 | 3.2 | 0 | na | na | na | na | PerClk | 5 |
| EOT0:3/TC0:3 | dc | dc | 6.4 | 2 | 10.3 | 7.1 | PerClk | 5 |
| PerAddr0:31 | 2.2 | 0 | 7.1 | 2 | 15.3 | 10.2 | PerClk | 5 |
| PerBLast | 3.3 | 0 | 6.5 | 2.3 | 10.3 | 7.1 | PerClk | 5 |
| PerCS0 | na | na | 6.5 | 2.1 | 10.3 | 7.1 | PerClk | 5 |
| PerCS1:7[GPIO10:16] | na | na | 6.5 | 2.1 | 10.3 | 7.1 | PerClk | 5 |
| PerData0:31 | 4.7 | 0.9 | 7.2 | 1.9 | 15.3 | 10.2 | PerClk | 5 |
| PerOE | na | na | 6.5 | 2.1 | 10.3 | 7.1 | PerClk | 5 |
| PerPar0:3 | 2.3 | 0 | 7.2 | 2.1 | 15.3 | 10.2 | PerClk | 5 |
| PerR/W | 3.3 | 0 | 6.6 | 2.1 | 10.3 | 7.1 | PerClk | 5 |
| PerReady | 5.5 | 0 | na | na | na | na | PerClk | 5 |
| PerWBE0:3 | 2.3 | 0 | 6.1 | 2.2 | 10.3 | 7.1 | PerClk | 5 |



PowerPC 405GPr Embedded Processor Data Sheet

I/O Specifications—Group 2 (Part 2 of 2)

Notes:

1. The SDRAM command interface is configurable through SDRAM0_TR[LDF] to provide a 2 to 4 cycle delay before the command is used by SDRAM.
2. SDRAM I/O timings are specified relative to a MemClkOut terminated into a lumped 10pF load.
3. SDRAM interface hold times are guaranteed at the PPC405GPr package pin. System designers must use the PPC405GPr IBIS model (available from www.chips.ibm.com) to ensure their clock distribution topology minimizes loading and reflections, and that the relative delays on clock wiring do not exceed the delays on other SDRAM signal wiring.
4. PerClk timing is specified with a 10pF load at the package pin. The indicated timing is valid only if PerClk feedback is selected. Refer to the *PowerPC 405GPr Embedded Processor User's Manual* for more information.
5. Input timings are specified at 1.5V, assuming transition times between 1 and 2ns, when measured between the 10% and 90% points of the output voltage.
6. I/O H is specified at 2.4 V and I/O L is specified at 0.4 V.

| Signal | Input (ns) | | Output (ns) | | Output Current (mA) | | Clock | Notes |
|---|-------------------------------------|------------------------------------|--------------------------------------|------------------------------------|---------------------|--------------------|--------|-------|
| | Setup Time (T _{IS} min) | Hold Time (T _{IH} min) | Valid Delay (T _{OV} max) | Hold Time (T _{OH} min) | I/O H (minimum) | I/O L (minimum) | | |
| External Master Peripheral Interface | | | | | | | | |
| BusReq | na | na | 6.1 | 2.2 | 10.3 | 7.1 | PerClk | 5 |
| ExtAck | na | na | 5.9 | 2.1 | 10.3 | 7.1 | PerClk | 5 |
| ExtReq | 4.1 | 0 | na | na | na | na | PerClk | 5 |
| ExtReset | na | na | 6 | 1 | 15.3 | 10.2 | PerClk | 5 |
| HoldAck | na | na | 6.1 | 2 | 10.3 | 7.1 | PerClk | 5 |
| HoldPri | 2.1 | 0 | na | na | na | na | PerClk | 5 |
| HoldReq | 3.1 | 0 | na | na | na | na | PerClk | 5 |
| PerClk | na | na | 0.7 | -0.5 | 15.3 | 10.2 | SysClk | 4, 5 |
| PerErr | 2.4 | 0 | na | na | na | na | PerClk | 5 |

PowerPC 405GPr Embedded Processor Data Sheet

Strapping

When the $\overline{\text{SysReset}}$ input is driven low by an external device (system reset), the state of certain I/O pins is read to enable default initial conditions prior to PPC405GPr start-up. The actual capture instant is the nearest SysClk edge before the deassertion of reset. These pins must be strapped using external pull-up (logical 1) or pull-down (logical 0) resistors to select the desired default conditions. The recommended pull-up is 3k Ω to +3.3V or 10k Ω to +5V. The recommended pull-down is 1K Ω to GND. These pins are use for strap functions only during reset. They are used for other signals during normal operation. The following tables list the strapping pins along with their functions and strapping options. The signal names assigned to the pins for normal operation follow the pin number.

The PPC405GPr can be used as a replacement for the PPC405GP. When the PPC405GPr is used for this purpose, it should be strapped to operate in the PPC405GPr Legacy Mode. This option is selected by strapping ball D20 (GPIO24) low (0). If Legacy Mode is selected, the “PPC405GPr Legacy Mode Strapping Pin Assignments” table should be used to determine the strapping options. To operate the chip as a PPC405GPr, strap D20 (GPIO24) high (1) and use “PPC405GPr New Mode Strapping Pin Assignments” on page 54 to determine the strapping options.

PPC405GPr Legacy Mode Strapping Pin Assignments (Part 1 of 2)

| Function | Option | Ball Strapping | | |
|--|----------------------------------|-----------------|------------------|-------------------|
| | | AF3 UART0_Tx | AF2 UART0_DTR | AD16 UART0_RTS |
| PLL Tuning ¹ for $6 \leq M \leq 7$ use choice 3 for $7 < M \leq 12$ use choice 5 for $12 < M \leq 32$ use choice 6 | Choice 1; TUNE[9:0] = 1010111100 | 0 | 0 | 0 |
| | Choice 2; TUNE[9:0] = 0100111000 | 0 | 0 | 1 |
| | Choice 3; TUNE[9:0] = 0100110110 | 0 | 1 | 0 |
| | Choice 4; TUNE[9:0] = 0100111100 | 0 | 1 | 1 |
| | Choice 5; TUNE[9:0] = 0100111000 | 1 | 0 | 0 |
| | Choice 6; TUNE[9:0] = 1000111100 | 1 | 0 | 1 |
| | Choice 7; TUNE[9:0] = 1000111110 | 1 | 1 | 0 |
| | Choice 8; TUNE[9:0] = 1011111110 | 1 | 1 | 1 |
| PLL Forward Divider ² | Bypass mode | 0 | 0 | |
| | Divide by 3 | 0 | 1 | |
| | Divide by 4 | 1 | 0 | |
| | Divide by 6 | 1 | 1 | |
| PLL Feedback Divider ² | Divide by 1 | 0 | 0 | |
| | Divide by 2 | 0 | 1 | |
| | Divide by 3 | 1 | 0 | |
| | Divide by 4 | 1 | 1 | |
| PLB Divider from CPU ² | Divide by 1 | 0 | 0 | |
| | Divide by 2 | 0 | 1 | |
| | Divide by 3 | 1 | 0 | |
| | Divide by 4 | 1 | 1 | |

PowerPC 405GPr Embedded Processor Data Sheet

PPC405GPr Legacy Mode Strapping Pin Assignments (Part 2 of 2)

| Function | Option | Ball Strapping | |
|--|-----------------------------|----------------------------|---------------------------------------|
| | | | |
| OPB Divider from PLB ² | | L25 EMCTxD1 | J26 EMCTxD0 |
| | Divide by 1 | 0 | 0 |
| | Divide by 2 | 0 | 1 |
| | Divide by 3 | 1 | 0 |
| | Divide by 4 | 1 | 1 |
| PCI Divider from PLB ^{2,3} | | D18 GPIO1[TS1E] | C20 GPIO2[TS2E] |
| | Divide by 1 | 0 | 0 |
| | Divide by 2 | 0 | 1 |
| | Divide by 3 | 1 | 0 |
| | Divide by 4 | 1 | 1 |
| External Bus Divider from PLB ² | | K25 EMCTxErr | K23 EMCTxEn |
| | Divide by 2 | 0 | 0 |
| | Divide by 3 | 0 | 1 |
| | Divide by 4 | 1 | 0 |
| | Divide by 5 | 1 | 1 |
| ROM Width | | AC2 UART1_Tx | AD2 UART1_RTS/ UART1_DTR |
| | 8-bit ROM | 0 | 0 |
| | 16-bit ROM | 0 | 1 |
| | 32-bit ROM | 1 | 0 |
| | Reserved | 1 | 1 |
| ROM Location | | U2 HoldAck | |
| | PPC405GPr Peripheral Attach | 0 | |
| | PPC405GPr PCI Attach | 1 | |
| PCI Asynchronous Mode Enable | | Y3 ExtAck | |
| | Synchronous PCI Mode | 0 | |
| | Asynchronous Mode | 1 | |
| PCI Arbiter Enable ³ | | AF18 GPIO4[TS2O] | |
| | Internal Arbiter Disabled | 0 | |
| | Internal Arbiter Enabled | 1 | |

Note:

1. The tune bits adjust parameters that control PLL jitter. The recommended values minimize jitter for the PLL implemented in the PPC405GPr. These bits are shown for information only; and do not require modification except in special clocking circumstances such as spread spectrum clocking. For details on the use of Spread Spectrum Clock Generators (SSCGs) with the PPC405GPr, visit the technical documents area of the IBM PowerPC web site.
2. Not all combinations of dividers produce valid operating configurations. Frequencies must be within the limits specified in "Clocking Specifications" on page 43. Further requirements are detailed in the Clocking chapter of the *PowerPC 405GPr Embedded Processor User's Manual*.
3. Additional consideration must be given to pins that normally function as Trace signals. Improved design margin can be gained by using three-state buffers instead of strapping resistors, and minimizing trace lengths and stubs.

PowerPC 405GPr Embedded Processor Data Sheet

PPC405GPr New Mode Strapping Pin Assignments (Part 1 of 3)

| Function | Option | Ball Strapping | | |
|---|----------------------------------|-----------------------|-----------------------|--------------------------|
| | | AF3 UART0_Tx | AF2 UART0_DTR | AD16 UART0_RTS |
| PLL Tuning See the <i>PowerPC 405GPr Embedded Processor User's Manual</i> for details. | Choice 1; TUNE[9:0] = 1010111100 | 0 | 0 | 0 |
| | Choice 2; TUNE[9:0] = 0100111000 | 0 | 0 | 1 |
| | Choice 3; TUNE[9:0] = 0100110110 | 0 | 1 | 0 |
| | Choice 4; TUNE[9:0] = 0100111100 | 0 | 1 | 1 |
| | Choice 5; TUNE[9:0] = 0100111000 | 1 | 0 | 0 |
| | Choice 6; TUNE[9:0] = 1000111100 | 1 | 0 | 1 |
| | Choice 7; TUNE[9:0] = 1000111110 | 1 | 1 | 0 |
| | Choice 8; TUNE[9:0] = 1011111110 | 1 | 1 | 1 |
| PLL Forward Divider A ² | | D16 DMAAck0 | B15 DMAAck1 | AC9 GPIO5[TS3] |
| | Divide by 8 | 0 | 0 | 0 |
| | Divide by 7 | 0 | 0 | 1 |
| | Divide by 6 | 0 | 1 | 0 |
| | Divide by 5 | 0 | 1 | 1 |
| | Divide by 4 | 1 | 0 | 0 |
| | Divide by 3 | 1 | 0 | 1 |
| | Divide by 2 | 1 | 1 | 0 |
| Divide by 1 | 1 | 1 | 1 | |
| PLL Forward Divider B ² | | P25 EMCTxD3 | L24 EMCTxD2 | AE8 GPIO6[TS4] |
| | Divide by 8 | 0 | 0 | 0 |
| | Divide by 7 | 0 | 0 | 1 |
| | Divide by 6 | 0 | 1 | 0 |
| | Divide by 5 | 0 | 1 | 1 |
| | Divide by 4 | 1 | 0 | 0 |
| | Divide by 3 | 1 | 0 | 1 |
| | Divide by 2 | 1 | 1 | 0 |
| Divide by 1 | 1 | 1 | 1 | |



PowerPC 405GPr Embedded Processor Data Sheet

PPC405GPr New Mode Strapping Pin Assignments (Part 2 of 3)

| Function | Option | Ball Strapping | | | |
|--|--------------|---------------------------|---------------------------------------|-------------------|-------------------|
| | | B14 DMAAck2 | C12 DMAAck3 | AF5 GPIO7[TS5] | AC7 GPIO8[TS6] |
| PLL Feedback Divider ^{2, 3} | | | | | |
| | Divide by 16 | 0 | 0 | 0 | 0 |
| | Divide by 1 | 0 | 0 | 0 | 1 |
| | Divide by 2 | 0 | 0 | 1 | 0 |
| | Divide by 3 | 0 | 0 | 1 | 1 |
| | Divide by 4 | 0 | 1 | 0 | 0 |
| | Divide by 5 | 0 | 1 | 0 | 1 |
| | Divide by 6 | 0 | 1 | 1 | 0 |
| | Divide by 7 | 0 | 1 | 1 | 1 |
| | Divide by 8 | 1 | 0 | 0 | 0 |
| | Divide by 9 | 1 | 0 | 0 | 1 |
| | Divide by 10 | 1 | 0 | 1 | 0 |
| | Divide by 11 | 1 | 0 | 1 | 1 |
| | Divide by 12 | 1 | 1 | 0 | 0 |
| | Divide by 13 | 1 | 1 | 0 | 1 |
| Divide by 14 | 1 | 1 | 1 | 0 | |
| Divide by 15 | 1 | 1 | 1 | 1 | |
| OPB Divider from PLB ² | | L25 EMCTxD1 | J26 EMCTxD0 | | |
| | Divide by 1 | 0 | 0 | | |
| | Divide by 2 | 0 | 1 | | |
| | Divide by 3 | 1 | 0 | | |
| | Divide by 4 | 1 | 1 | | |
| PCI Divider from PLB ^{2, 3} | | D18 GPIO1[TS1E] | C20 GPIO2[TS2E] | | |
| | Divide by 1 | 0 | 0 | | |
| | Divide by 2 | 0 | 1 | | |
| | Divide by 3 | 1 | 0 | | |
| | Divide by 4 | 1 | 1 | | |
| External Bus Divider from PLB ² | | K25 EMCTxErr | K23 EMCTxEn | | |
| | Divide by 2 | 0 | 0 | | |
| | Divide by 3 | 0 | 1 | | |
| | Divide by 4 | 1 | 0 | | |
| | Divide by 5 | 1 | 1 | | |
| ROM Width | | AC2 UART1_Tx | AD2 UART1_RTS/ UART1_DTR | | |
| | 8-bit ROM | 0 | 0 | | |
| | 16-bit ROM | 0 | 1 | | |
| | 32-bit ROM | 1 | 0 | | |
| | Reserved | 1 | 1 | | |

PowerPC 405GPr Embedded Processor Data Sheet

PPC405GPr New Mode Strapping Pin Assignments (Part 3 of 3)

| Function | Option | | Ball Strapping |
|---|-----------------------------------|-----------------------------|----------------|
| ROM Location | | U2 HoldAck | |
| | PPC405GPr Peripheral Attach | 0 | |
| | PPC405GPr PCI Attach | 1 | |
| PCI Asynchronous Mode Enable | | Y3 ExtAck | |
| | Synchronous PCI Mode | 0 | |
| | Asynchronous Mode | 1 | |
| External Bus Synchronous Mode Enable ³ | | A22 GPIO3[TS1O] | |
| | Asynchronous Mode | 0 | |
| | Synchronous Mode | 1 | |
| PCI Arbiter Enable ³ | | AF18 GPIO4[TS2O] | |
| | Internal Arbiter Disabled | 0 | |
| | Internal Arbiter Enabled | 1 | |
| New Mode Enable In Legacy mode the PPC405GPr functions like the PPC405GP. If not strapped, the PPC405GPr defaults to Legacy mode. | | D20 GPIO24 | |
| | Legacy (PPC405GP) mode | 0 | |
| | New (PPC405GPr) mode ⁴ | 1 | |
| Flip Circuit Disable (must be strapped low (0) during initialization). | | AB3 GPIO9[TrcClk] | |
| | Normal operation | 0 | |

Note:

1. The tune bits adjust parameters that control PLL jitter. The recommended values minimize jitter for the PLL implemented in the PPC405GPr. These bits are shown for information only; and do not require modification except in special clocking circumstances such as spread spectrum clocking. For details on the use of Spread Spectrum Clock Generators (SSCGs) with the PPC405GPr, visit the technical documents area of the IBM PowerPC web site.
2. Not all combinations of dividers produce valid operating configurations. Frequencies must be within the limits specified in "Clocking Specifications" on page 43. Further requirements are detailed in the Clocking chapter of the *PowerPC 405GPr Embedded Processor User's Manual*.
3. Additional consideration must be given to pins that normally function as Trace signals. Improved design margin can be gained by using three-state buffers instead of strapping resistors, and minimizing trace lengths and stubs.
4. The pull-up initialization strapping resistor must be 1 k Ω rather than 3 k Ω in order to overcome the internal pull-down resistor.

Revision Log

| Date | Contents of Modification |
|------------|---|
| 03/13/2003 | 400MHz part numbers and new power/current numbers |



PowerPC 405GPr Embedded Processor Data Sheet

Inside of back cover



PowerPC 405GPr Embedded Processor Data Sheet

(c) Copyright International Business Machines Corporation 1999, 2003

All Rights Reserved

Printed in the United States of America, March 2003

The following are trademarks of International Business Machines Corporation in the United States, or other countries, or both:

| | | |
|------------|-------------|----------|
| Blue Logic | CoreConnect | IBM Logo |
| CodePack | IBM | PowerPC |

Other company, product, and service names may be trademarks or service marks of others.

Preliminary Edition (3/14/03)

This document contains information on a new product under development by IBM. IBM reserves the right to change or discontinue this product without notice.

This document is a preliminary edition of the PowerPC 405GPr data sheet. Make sure you are using the correct edition for the level of the product.

While the information contained herein is believed to be accurate, such information is preliminary, and should not be relied upon for accuracy or completeness, and no representations or warranties of accuracy or completeness are made.

All information contained in this document is subject to change without notice. The products described in this document are NOT intended for use in implantation, life support, or other hazardous uses where malfunction could result in death, bodily injury, or catastrophic property damage. The information contained in this document does not affect or change IBM product specifications or warranties. Nothing in this document shall operate as an express or implied license or indemnity under the intellectual property rights of IBM or third parties. All information contained in this document was obtained in specific environments, and is presented as an illustration. The results obtained in other operating environments may vary.

THE INFORMATION CONTAINED IN THIS DOCUMENT IS PROVIDED ON AN "AS IS" BASIS. In no event will IBM be liable for damages arising directly or indirectly from any use of the information contained in this document.

IBM Microelectronics Division
1580 Route 52
Hopewell Junction, NY 12533-6351

The IBM home page is www.ibm.com.

The IBM Microelectronics Division home is www.chips.ibm.com.

SA14-2609-03