



1063/1250Mb/s Small Form Factor Transceiver with Signal Detect

Features

- International Class 1 laser safety certified
- 1063Mb/s to 1250Mb/s data rates
- (ANSI) Fibre Channel compliant [1]
- (IEEE 802.3z/d2) Gigabit Ethernet compliant [2]
- Short wavelength (SW) (distance \leq 550m)
- Gigabit electrical serial interface
- Serial electrical \leftrightarrow light conversion
- UL & CSA approved
- LVTTTL Signal-Detect Output
- Single +3.3V Power Supply
- Low bit error rate ($< 10^{-12}$)
- High reliability
 - AFR < 0.01 %/khr @50 C

Applications

- Gigabit Fibre Channel
- Gigabit Ethernet
- Client/Server environments
- Distributed multi-processing
- Fault tolerant applications
- Visualization, real-time video, collaboration
- Channel extenders, data storage, archiving
- Data acquisition

Description

The 1063 / 1250 Mb/s Serial Optical Converter (SFF-1063/1250N-SW) is an integrated fiber optic transceiver that provides a high-speed serial link at a signaling rate of 1062.5 to 1250 Mb/s. The SFF-1063/1250N-SW conforms to the American National Standards Institute's (ANSI) Fibre Channel, FC-0 specification for short wavelength operation (100-M5-SN-I and 100-M6-SN-I). It also conforms to draft 2 of the IEEE 802.3z, 1000Base-SX standard [2].

The SFF-1063/1250N-SW is ideally suited for Fibre Channel Arbitrated Loop (FC-AL) and Gigabit Ethernet applications, but can be used for other serial applications where high data rates are required. This specification applies to a pin through hole (PTH) module which has a 2 by 5 electrical connector pin configuration.

The SFF-1063/1250N-SW uses a short wavelength (850nm) VCSEL (Vertical Cavity Surface Emitter Laser) source. This enables low cost data transmission over optical fibers at distances up to 550m. A 50/125 μ m multimode optical fiber, terminated with

an industry standard LC connector, is the preferred medium. (A 62.5/125 μ m multimode fiber can be substituted with shorter maximum link distances.)

Encoded (8B/10B) [3], [4], gigabit/sec, serial, differential, PECL signals traverse a connector interfacing the SFF-1063/1250N-SW to the host card. The serial data modulates the laser and is sent out over the outgoing fiber of a duplex cable.

Incoming, modulated light is detected by a photoreceiver mounted in the LC receptacle. The optical signal is converted to an electrical one, amplified and delivered to the host card. This module is designed to work with industry standard "10b" Serializer/Deserializer modules.

The SFF-1063/1250N-SW is a Class 1 laser safe product. The optical power levels, under normal operation, are at eye safe levels. Optical fiber cables can be connected and disconnected without shutting off the laser transmitter.

IBM42F10SNNA20
 IBM42F12SNNA20
1063/1250Mb Small Form Factor Transceiver with Signal Detect

Package Outline

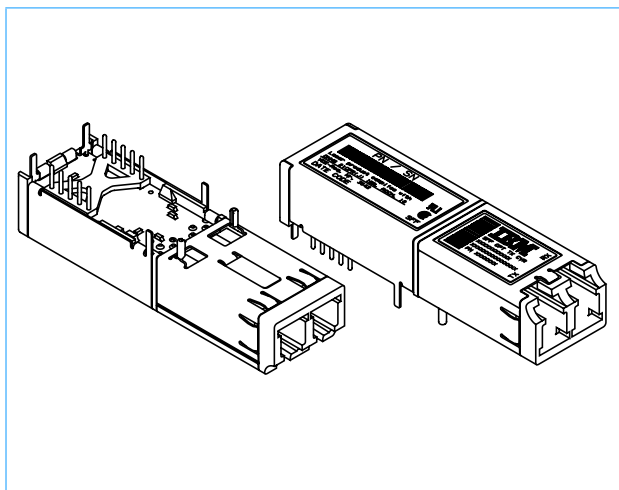

Pin Assignments

Pin Name	Type	Pin #
Rx Ground	Ground	1
Rx Power	Power	2
Rx_SD	Status Out	3
Rx_DAT -	Signal Out	4
Rx_DAT +	Signal Out	5
Tx Power	Power	6
Tx Ground	Ground	7
Tx_Disable	Control In	8
Tx_DAT +	Signal In	9
Tx_DAT -	Signal In	10

Ordering Information

Product Descriptor	Part Number	Signaling Rate	Wavelength
SFF-1063/1250N-SW	IBM42F10SNNA20	1062.5Mb/s	850nm
	IBM42F12SNNA20	1250Mb/s	

Laser Safety Compliance Requirements

The SFF-1063/1250N-SW is designed and certified as a Class 1 laser product. If the power supply voltage exceeds 4.0 volts, this may no longer remain a Class 1 product. The system using the SFF-1063/1250N-SW must provide power supply over voltage protection that guarantees the supply does not exceed 4.0 volts under all fault conditions.

Caution: Operating the power supply above 4.0V or otherwise operating the SFF-1063/1250N-SW in a manner inconsistent with its design and function may result in hazardous radiation exposure, and may be considered an act of modifying or new manufacturing of a laser product under US regulations contained in 21 CFR(J) or CENELEC regulations contained in EN 60825. The person(s) performing such an act is required by law to recertify and reidentify the product in accordance with the provisions of 21 CFR(J) for distribution within the United States, and in accordance with provisions of CENELEC EN 60825 (or successive regulations) for distribution within the CENELEC countries or countries using the IEC 825 standard.

ESD Handling

Take normal static precautions during handling and assembly of the SFF-1063/1250N-SW to prevent damage and/or degradation that can be induced by electrostatic discharge.

Block Diagram

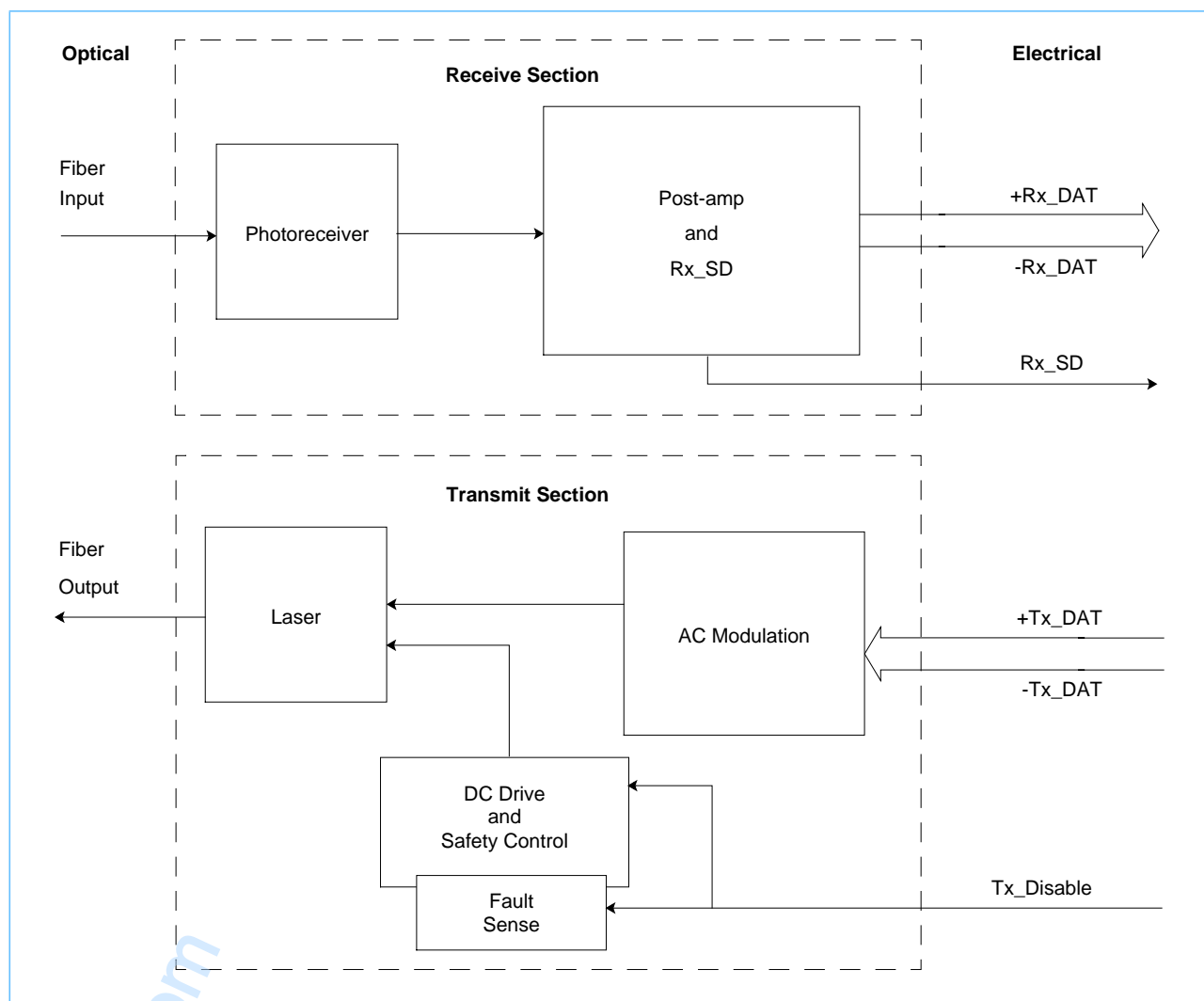

Transmit Section

The input, an AC coupled differential data stream from the host, enters the AC Modulation section of the laser driver circuitry where it modulates the output optical intensity of a semiconductor laser. The DC Drive maintains the laser at the correct preset power level. In addition, safety circuits in the DC Drive will shut off the laser if a fault is detected. *The host must provide the AC coupling for the +Tx/-Tx lines.* A 10nF capacitor is recommended.

Receive Section

The incoming modulated optical signal is converted to an electrical signal by the photoreceiver. This electrical signal is then amplified and converted to a differential serial output data stream and delivered to the host. A transition detector detects sufficient AC level of modulated light entering the photoreceiver. This signal is provided to the host as a signal detect status line. *The host must provide the AC coupling for the +Rx/-Rx lines.* A 10 nF capacitor is recommended.

IBM42F10SNNA20
 IBM42F12SNNA20
1063/1250MbD Small Form Factor Transceiver with Signal Detect

Input Signal Definitions

Levels for the signals described in this section are listed in Transmit Signal Interface on page 8 and Control Electrical Interface on page 9.

Tx_DAT

A differential PECL serial data stream is presented to the SFF-1063/1250N-SW for transmission onto an optical fiber by modulating the optical output intensity of a laser.

Tx_Disable

When high (logic one), the Tx_Disable signal turns off the power to both the AC and DC laser driver circuits. It will also reset a laser fault if one should happen. When low (logic zero), the laser will be turned on within 1ms if a hard fault is not detected. This signal should be driven with push-pull driver.

Also, this signal has a pull-down resistor on the transceiver so if the host does not drive this signal the laser will default to the on state.

Timing of Tx_Disable

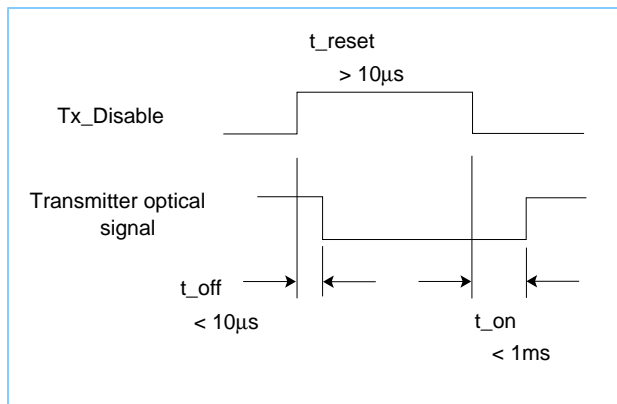

Output Signal Definitions

Levels for the signals described in this section are listed in Receive Signal Interface on page 8 and Control Electrical Interface on page 9.

Rx_DAT

The incoming optical signal is converted and repowered as a differential, PECL, serial data stream. The Receive Signal Interface table on page 8 gives the voltage levels and timing characteristics for the Rx_DAT signals.

Rx_SD

The Receive Signal Detect line is high (a logical one) when the incoming modulated light intensity is sufficient for reliable operation. This is the state for normal operation. The line is low (a logical zero) when incoming modulated light intensity is below that required to guarantee the correct operation of the link. Normally, this only occurs when either the link is unplugged or the companion transceiver is turned off. This signal is normally used by the system for diagnostic purposes.

This signal has a push-pull output driver.

Timing of Rx_SD

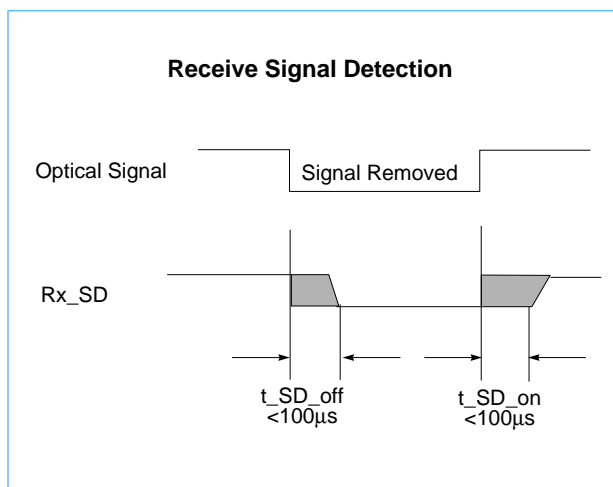



Operation

Initialization Timings

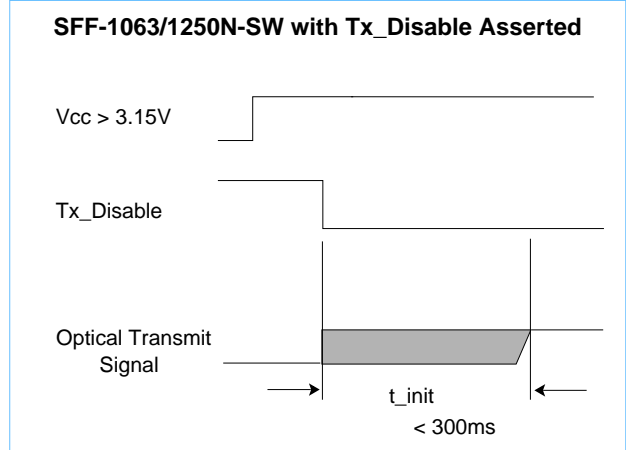
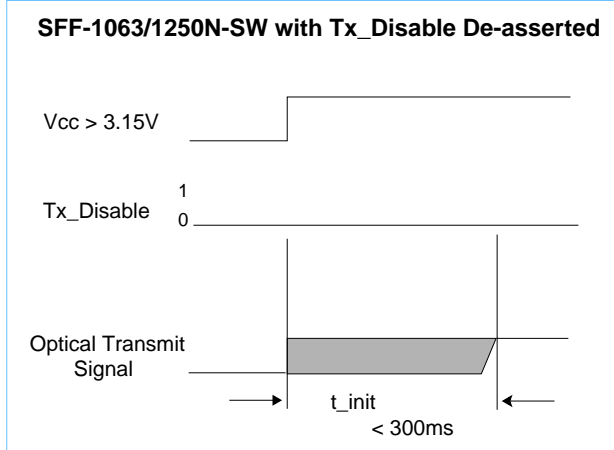

Resetting a Laser Fault

Resetting a laser fault by toggling the Tx_Disable input will permit the SFF-1063/1250N-SW to attempt to power on the laser following a fault condition. *Continuous resetting and repowering of the laser under a hard fault condition could cause a series of optical pulses with sufficient energy to violate laser safety standards.*

To alleviate this possibility, the SFF-1063/1250N-SW will turn off the laser if a second fault is detected within 25ms of the laser powering on. This lock is cleared during each power on cycle. Please refer to the timing diagrams below.

Fault Condition Recovery Timings

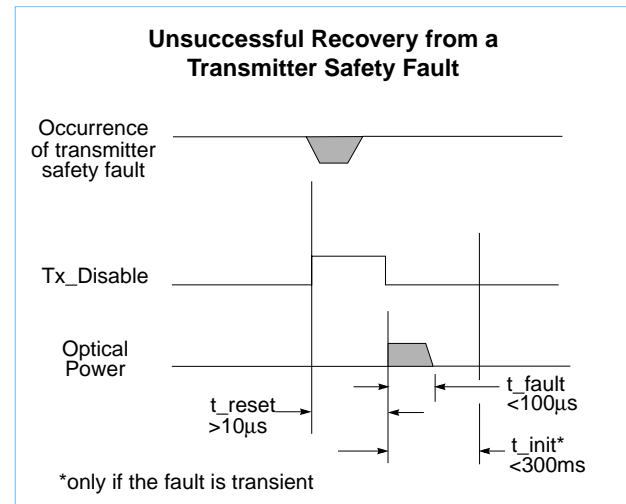
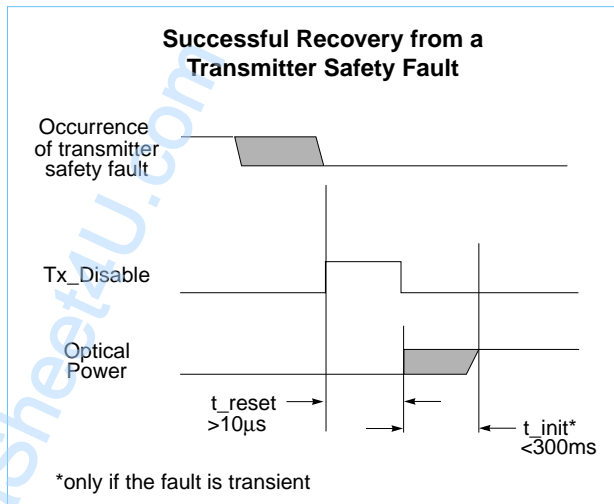



IBM42F10SNNA20
IBM42F12SNNA20
1063/1250Mb Small Form Factor Transceiver with Signal Detect

Link Acquisition Sequence

The following sequence should be followed to get an IBM SFF-1063/1250N-SW in full synchronization with a companion card undergoing a similar sequence. It will also work with a single card when using an optical wrap connector. This sequence assumes the use of an industry standard 10b chip.

1. Power up the node. The Clock to the 10b chip should be running.
2. Drive the Transmit Data lines to 0101010101. (This speeds up the synchronization process and assures that the Comma Detect line on the Ser/Des chip will not pulse randomly on the companion card during the remainder of the sequence.)
3. Drive the input control lines as follows:
 - a. Enable Wrap (10b chip): low (will not be changed)
 - b. Enable Comma Detect (10b chip): high (will not be changed)
 - c. $\overline{\text{Lock to Reference}}$ (10b chip): high
4. After the laser has come on, bring $\overline{\text{Lock to Reference}}$ low for at least 500 μ s.
5. Bring the $\overline{\text{Lock to Reference}}$ signal high.
6. After 2500 bit times (2.4 μ s), the link should be in bit synchronization (the internal clocks are aligned to the incoming bit stream), but not yet byte synchronization (the byte is aligned along the same boundary it had when sent from the companion system to the SFF prior to serialization). The Receive Byte Clock (10b chip) frequency should now be running at 0.1 times the bit rate and the Comma Detect line is ready to indicate reception of the Comma Character.
7. Drive the Transmit Data lines with a K28.5 (Byte Sync) character.

As soon as the 10b chip receives the K28.5 character from the other side of the link, the clocks will align to the byte boundary and all the Receive Data lines will have valid data. This will be indicated by the activation of the Comma Detect line.

Troubleshooting: What If...

The laser never comes on:

- Verify 3.3 volts on the connector to the SFF-1063/1250N-SW and that the module is correctly connected.
- Try either unplugging and replugging or powering down the module to reset the fault lock (see Resetting a Laser Fault on page 5).
- Verify that Tx_Disable is low and that it toggles correctly on the connector.
- Try another SFF-1063/1250N-SW. If it operates correctly then retry the original. If it still fails, it is probably defective.

The Rx_SD signal remains low:

- Verify 3.3 volts on the connector to the SFF-1063/1250N-SW and that the module is correctly plugged.
- Try using a wrap connector or a simplex jumper to loop the transmitter to the receiver. If the Rx_SD line goes low, the source of the optical signal or the link may be defective. Use an optical power meter to check this. If the average optical power is within specification (> -17dBm), then the SFF-1063/1250N-SW may be faulty.



Absolute Maximum Ratings

Symbol	Parameter	Min.	Typical	Max.	Unit	Notes
T _S	Storage Temperature	-40		75	°C	1
T _{SOLD}	Connector Pin Temp during soldering			165/5	°C/s	1,3
T _{SOLD}	Optics Temperature during soldering			100/60	°C/s	4
RH _S	Relative Humidity–Storage	0		95	%	1, 2
T _{OP}	Ambient Operating Temperature	-10		70	°C	1
RH _{OP}	Relative Humidity Operating	8		80	%	1, 2
V _{CC}	Supply Voltage	-0.5		4.0	V	1
V _I	TTL DC Input Voltage	0		V _{CC} + 0.7	V	1
ESD _{EP}	HBM ESD Rating to Electrical Pins			1500	V	5
ESD _{LC}	HBM ESD Rating to LC Receptacle			12000	V	

1. Stresses listed may be applied one at a time without causing permanent damage. Exposure to these values for extended periods may affect reliability. Specification Compliance is only defined within Specified Operating Conditions.
2. Non-condensing environment.
3. The connector pin temperature can be measured with a thermocouple attached to pin 3 of 2x5 header
4. The optics temperature can be measured with a thermocouple on the device with the cover off.
5. The HBM (human body model) is a 100pF capacitor discharged through a 1.5KΩ resistor into each pin per MIL-STD-883C.

Specified Operating Conditions

Symbol	Parameter	Min.	Typical	Max.	Unit
T _{OP}	Ambient Operating Temperature	0		70	°C
V _{DDT} , V _{DDR}	Supply Voltage	3.135	3.3	3.465	V
RH _{OP}	Relative Humidity Operating	8		80	%

Power Supply Interface

Symbol	Parameter	Min	Typical	Max.	Unit
I	Total Current (@ 3.3V)		120		mA
I	Total Current (@ 3.465V)			200	mA
	Ripple & Noise			100	mV(pk-pk)

IBM42F10SNNA20
 IBM42F12SNNA20
1063/1250MbD Small Form Factor Transceiver with Signal Detect

Transmit Signal Interface (from host to SFF-1063/1250N-SW)

Symbol	Parameter	Min	Max.	Unit	Notes
V_o	PECL Amplitude	400	2000	mV	1
$DJ_{\text{elec-xmit}}$	PECL Deterministic Jitter		0.12	UI	2
$TJ_{\text{elec-xmt}}$	PECL Total Jitter		0.25	UI	2
	PECL Rise/Fall	100	350	ps	3
	PECL Differential Skew		20	ps	

1. At 100 Ω , differential peak-to-peak, the figure below shows the simplified circuit schematic for the SFF-1063/1250N-SW high-speed differential input lines. Note the input data lines require AC coupling capacitors on the host. A 10nF value is recommended.

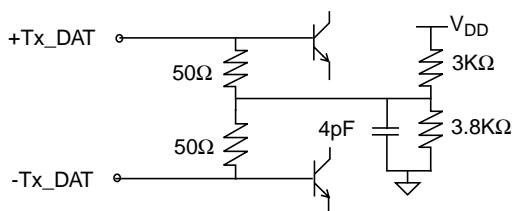

2. Deterministic jitter (DJ) and total jitter (TJ) values are measured according to those defined in Annex A, FC-PH rev 4.3. Jitter values at the output of a transmitter or receiver section assume worst case jitter values at its respective input. The Unit interval (UI) for 1062.5Mb/s is 941ps. The UI for 1250Mb/s is 800ps.
3. Rise and fall times are measured from 20 - 80%, 100 Ω differential.

Receive Signal Interface (from SFF-1063/1250N-SW to host)

Symbol	Parameter	Min	Max.	Unit	Note(s)
V_o	PECL Amplitude	600	1000	mV	1
$DJ_{\text{elec-rcv}}$	PECL Deterministic Jitter		0.36	UI	2
$TJ_{\text{elec-rcv}}$	PECL Total Jitter		0.61	UI	2
	PECL Differential Skew		205	ps	

1. At 100 Ω , differential peak-to-peak, the figure below shows the simplified circuit schematic for the SFF-1063/1250N-SW high-speed differential output lines. Note the output data lines require AC coupling capacitors on the host. A 10nF capacitor is recommended.

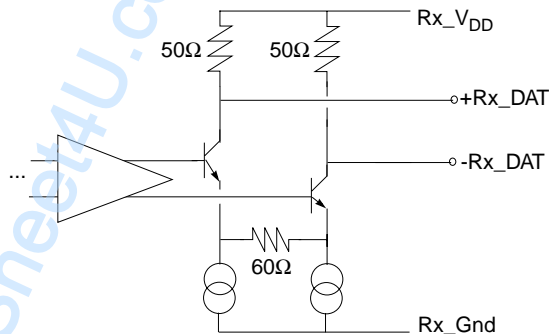

2. Deterministic jitter (DJ) and total jitter (TJ) values are measured according to those defined in Annex A, FC-PH rev 4.3. Jitter values at the output of a transmitter or receiver section assume worst case jitter values at its respective input. The Unit interval (UI) for 1062.5Mb/s is 941ps. The UI for 1250Mb/s is 800ps.



Control Electrical Interface

Symbol	Parameter	Min	Max.	Unit	Note(s)
Voltage Levels					
V_{OL}	TTL Output (from SFF-1063/1250N-SW)	0.0	0.50	V	1
V_{OH}		$V_{CC}-0.5$	$V_{CC}+0.3$	V	
V_{IL}	TTL Input (to SFF-1063/1250N-SW)	0	0.8	V	2
V_{IH}		2.0	$V_{DDT}+0.3$	V	
Timing Characteristics					
t_{off}	Tx_Disable (assert time)		10	μ s	3
t_{on}	Tx_Disable (de-assert time)		1	ms	3
t_{reset}	Tx_Disable (time to start reset)	10		μ s	3
t_{init}	Initialization Time		300	ms	4
t_{SD_on}	Rx_SD Assert Delay		100	μ s	5
t_{SD_off}	Rx_SD De-Assert Delay		100	μ s	5
<ol style="list-style-type: none"> 1. A 4.7K - 10KΩ pull-up resistor to host V_{CC} is required. 2. A 1KΩ pull-down resistor to GND is present on the SFF-1063/1250N-SW to allow the laser to be active when no input signal is provided on Tx_Disable. 3. See Tx_Disable on page 4 and Operation on page 5 for timing relationships. 4. See Operation on page 5. 5. See Rx_SD on page 4 for timing relations. 					



IBM42F10SNNA20
 IBM42F12SNNA20
1063/1250Mb Small Form Factor Transceiver with Signal Detect

Optical Specifications

Common Receiver and Transmitter Specifications

Symbol	Parameter	Min	Typical	Max.	Unit	Notes
OPB	Optical Power Budget	5.5			dB	1

1. This 5.5dB optical power budget is a result of the difference between the worst case transmitted launch power and the receiver sensitivity plus 2dB power penalty per Fibre Channel.

Receiver Specifications

Symbol	Parameter	Min	Typical	Max.	Unit	Notes
λ	Operating Wavelength	770		860	nm	
	Received Power	-17.0		0.0	dBm(avg)	1
RL	Return Loss of Receiver	12			dB	
P _{off}	Rx_SD De-Assert (negate) Level	-27.0		-17.5	dBm(avg)	2
P _{on}	Rx_SD Assert Level			-17.0	dBm(avg)	2
	Rx_SD Hysteresis		1		dB(optical)	2

1. The minimum and maximum values of the average received power in dBm give the input power range to maintain a BER 10^{-12} when the data is sampled in the center of the receiver eye. These values take into account power penalties caused by the use of a laser transmitter with a worst-case combination of spectral width, extinction ratio and pulse shape characteristics.
2. The Rx_SD has hysteresis to minimize "chatter" on the output line. In principle, hysteresis alone does not guarantee chatter-free operation. The SFF-1063/1250N-SW, however, presents an Rx_SD line without chatter, where chatter is defined as a transient response having a voltage level of greater than 0.5 volts (in the case of going from the negate level to the assert level) and of any duration that can be sensed by the host logic.



Transmitter Specifications

Symbol	Parameter	Min	Typical	Max.	Unit	Notes
λ_c	Spectral Center Wavelength	830		860	nm	
$\Delta\lambda$	Spectral Width			0.85	nm(rms)	
PT	Launched Optical Power	-9.5		-4.0	dBm(avg)	1
T_{rise}/T_{fall}	Optical Rise/Fall Time			0.26	ns	2
	Optical Extinction Ratio	9			dB	3
RIN ₁₂	Relative Intensity Noise			-117	dB/Hz	4
	Eye Opening	0.57			UI	5
DJ	Deterministic Jitter			0.20	UI	6
CPR	Coupled Power Ratio	9			dB	7

1. Launched optical power is measured at the end of a two meter section of a 50/125m fiber (N.A.=0.20). The maximum and minimum of the allowed range of average transmitter power coupled into the fiber are worst case values to account for manufacturing variances, drift due to temperature variations, and aging effects.
2. Optical rise time is determined by measuring the 20-80% of average maximum values using an oscilloscope and 4th order Bessel Thompson filter having a 3dB bandwidth of 796MHz and then correcting the measurement to the full bandwidth value. Optical fall times are measured using a 6GHz photodetector followed by a 22GHz sampling oscilloscope. No corrections due to filtering or system bandwidth limitations are made on the measured value.
3. Extinction Ratio is the ratio of the average optical power (in dB) in a logic level one to the average optical power in a logic level zero measured under fully modulated conditions in the presence of worst case reflections.
4. RIN₁₂ is the laser noise, integrated over a specified bandwidth, measured relative to average optical power with 12dB return loss. See ANSI Fibre Channel Specification Annex A.5.
5. Eye opening is the portion of the bit time where the bit error rate (BER) $\leq 10^{-12}$. The general laser transmitter pulse shape characteristics are specified in the form of a mask of the transmitter eye diagram. These characteristics include pulse overshoot, pulse undershoot, and ringing, all of which should be controlled to prevent excessive degradation of the receiver sensitivity. For the purpose of an assessment of the transmit signal, it is important to consider not only the eye opening, but also the overshoot and undershoot limitations.
6. Deterministic Jitter is measured as the peak-to-peak timing variation of the 50% optical signal crossings when transmitting repetitive K28.5 characters. It is defined in FC-PH, version 4.3, clause 3.1.87 as:

Timing distortions caused by normal circuit effects in the transmission system. Deterministic jitter is often subdivided into duty cycle distortion (DCD) caused by propagation differences between the two transitions of a signal and data dependent jitter (DDJ) caused by the interaction of the limited bandwidth of the transmission system components and the symbol sequence.
7. Coupled Power Ratio is the ratio of the average power coupled into a multimode fiber to the average power coupled into a single mode fiber. This measurement is defined in EIA/TIA-526-14A.

IBM42F10SNNA20
 IBM42F12SNNA20
1063/1250Mb Small Form Factor Transceiver with Signal Detect

Optical Cable/Connector Cable Specifications

Symbol	Parameter	Min	Typical	Max.	Unit	Notes
50/125 μm Cable and Connector Specifications						
L	Length	2		550	m	
BW	Bandwidth @ $\lambda = 850\text{nm}$	500			MHz-km	
μ_c	Attenuation @ $\lambda = 850\text{nm}$			3.5	dB/km	
N.A.	Numerical Aperture		0.20			
62.5/125 μm Cable Specifications						
	Length	2		250	m	
BW	Bandwidth @ $\lambda = 850\text{nm}$	200			MHz-km	
	Attenuation @ $\lambda = 850\text{nm}$			3.75	dB/km	
N.A.	Numerical Aperture		0.275			
LC Optical Connector						
μ_{con}	Nominal Attenuation		0.3	0.5	dB	1
σ_{con}	Attenuation Standard Deviation		0.2		dB	1
	Connects/Disconnects			250	cycles	1
1. The optical interface connector dimensionally conforms to the industry standard LC type connector documented in JIS-5973. A dual keyed LC receptacle mechanically aligns the optical transmission fiber to the SFF-1063/1250N-SW.						

Reliability Projections

Parameter	Symbol	Max.	Unit	Note
Average Failure Rate	AFR	0.0100	%/khr	1
Average Failure Rate	AFR	0.0195	%/khr	2
1. AFR specified over 44 khours at 50 C, with minimum airflow of 100fpm. 2. AFR specified over 44 khours at 60 C, with minimum airflow of 100fpm.				

Soldering Information

The SFF comes with a dust plug. The purpose of the dust plug is to keep the optical port clean and can be used during a wave soldering process. The SFF module is NOT washable. Any soldering process is allowed as long as it meets the temperature criteria in the Absolute Maximum Ratings table and uses only a "no clean" flux process. That way, the SFF will not get wet any time during the attachment process.



Mechanical Description

Card Layout

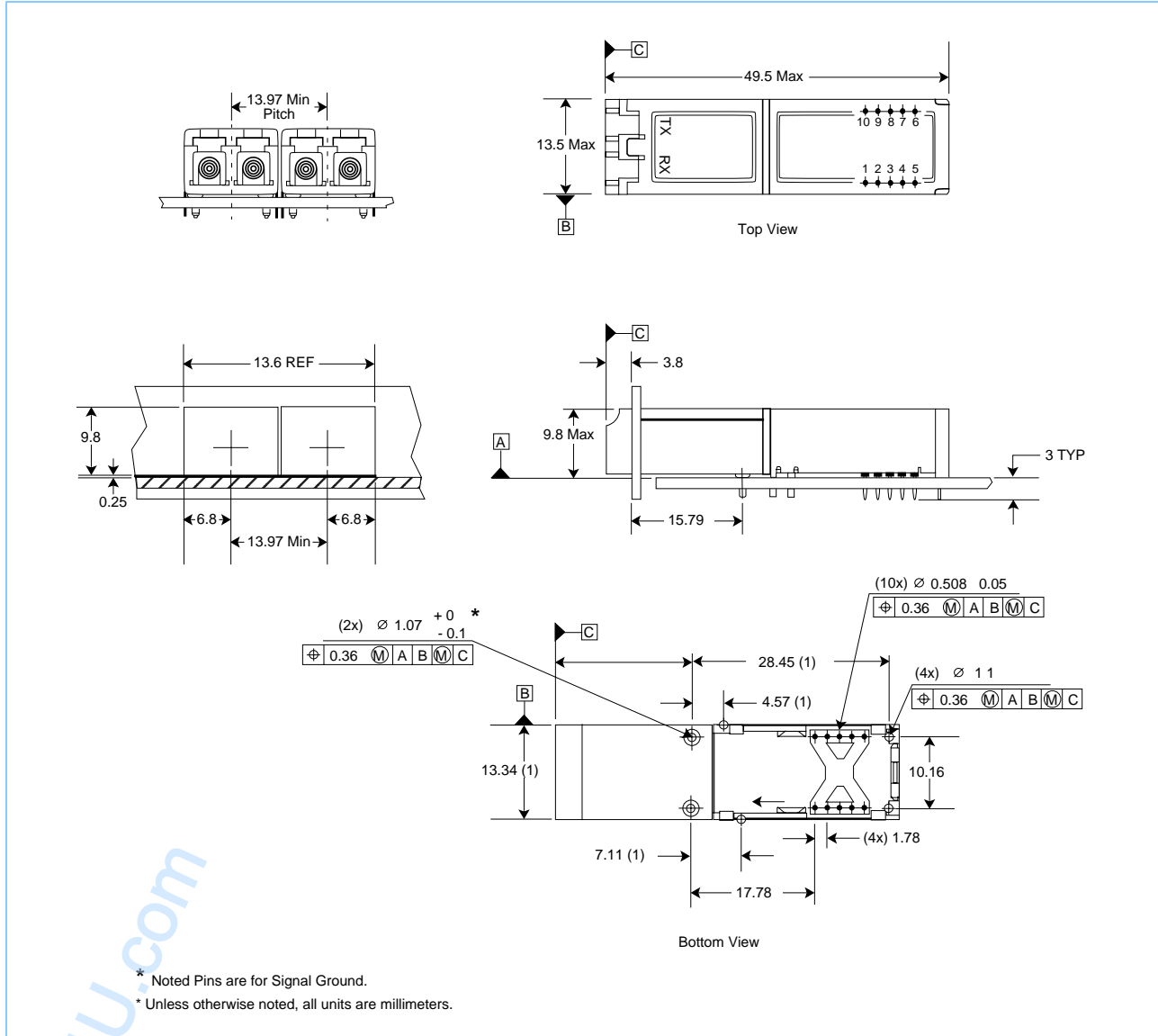

The SFF-1063/1250N-SW is intended to be used on a host card having a thickness of 0.062" to 0.100". The host card footprint with essential keepouts and drill holes is shown in Host Card Footprint on page 14.

IBM42F10SNNA20
IBM42F12SNNA20
1063/1250Mb Small Form Factor Transceiver with Signal Detect

Host Card Footprint

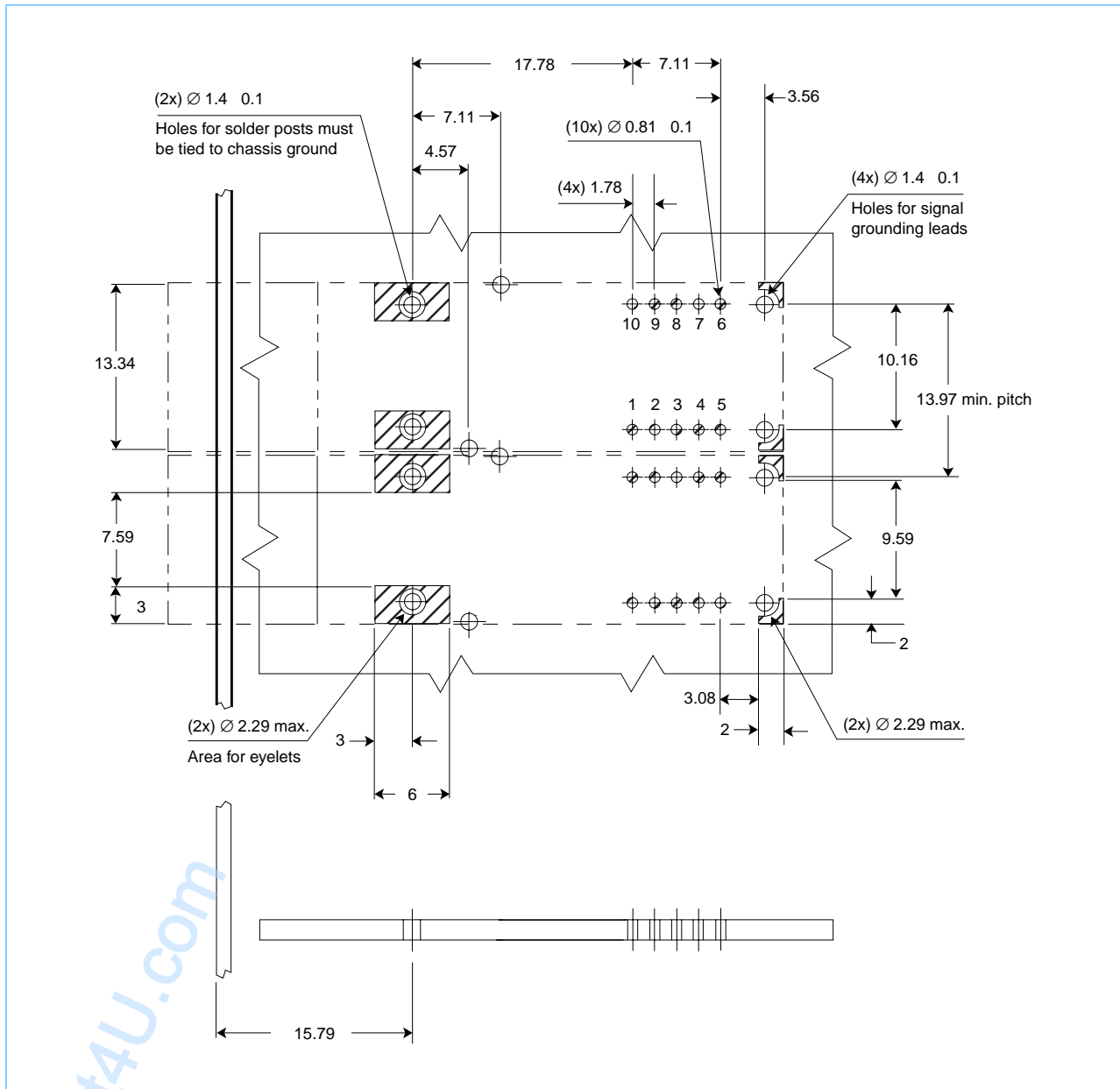



References

Standards

1. American National Standards Institute Inc. (ANSI), X3T11, Fibre Channel-Physical and Signaling Interface (FC-PH). Copies of this document may be purchased from:
Global Engineering
15 Inverness Way East
Englewood, CO 80112-5704
Phone: (800) 854-7179 or (303) 792-2181
Fax: (303) 792-2192.
2. IEEE 802.3z Draft 5.0. Drafts of this standard are available to members of the standards working committee. For further information see IEEE 802.3z public reflector at stds-802-3-hssg@mail.ieee.org. To be added to the reflector, send an E-mail to:
majordomo@mail.ieee.org

containing the line:

subscribe stds-802-3-hssg <your email address>

The ftp site is

ftp://stdsbbs.ieee.org/pub/802_main/802.3/gigabit

Industry Specifications

3. A.X. Widmer and P.A. Franaszek, "A DC-Balanced, Partitioned-Block, 8B/10B Transmission Code," *IBM Journal of Research and Development*, vol. 27, no. 5, pp. 440-451, September 1983. This paper fully defines the 8B/10B code. It is primarily theoretical.
4. A.X. Widmer, The ANSI Fibre Channel Transmission Code, *IBM Research Report, RC 18855 (82405)*, April, 23 1993. Copies may be requested from:
Publications
IBM Thomas J. Watson Research Center
Post Office Box 218
Yorktown Heights, New York 10598
Phone: (914) 945-1259
Fax: (914) 945-4144



IBM42F10SNNA20
IBM42F12SNNA20
1063/1250Mb Small Form Factor Transceiver with Signal Detect

Revision Log

Date	Description of Modification
1/24/00	Initial release (00).

www.DataSheet4U.com



IBM42F10SNNA20

IBM42F12SNNA20

1063/1250Mb Small Form Factor Transceiver with Signal Detect

www.DataSheet4U.com



© Copyright International Business Machines Corporation 2000.

All Rights Reserved
Printed in the United States of America, January 2000

The following are trademarks of International Business Machines Corporation in the United States, or other countries, or both.

IBM IBM Logo

Other company, product and service names may be trademarks or service marks of others.

All information contained in this document is subject to change without notice. The products described in this document are NOT intended for use in implantation or other life support applications where malfunction may result in injury or death to persons. The information contained in this document does not affect or change IBM product specifications or warranties. Nothing in this document shall operate as an express or implied license or indemnity under the intellectual property rights of IBM or third parties. All information contained in this document was obtained in specific environments, and is presented as an illustration. The results obtained in other operating environments may vary.

THE INFORMATION CONTAINED IN THIS DOCUMENT IS PROVIDED ON AN "AS IS" BASIS. In no event will IBM be liable for damages arising directly or indirectly from any use of the information contained in this document.

IBM Microelectronics Division
1580 Route 52, Bldg. 504
Hopewell Junction,
NY 12533-6351

The IBM home page can be found at
<http://www.ibm.com>

The IBM Microelectronics Division home page
can be found at <http://www.chips.ibm.com>

SFF.02
1/24/00

www.DataSheet4U.com