

Switched-Capacitor Voltage Inverter

The ICL828 IC performs supply voltage conversions from positive to negative for an input range of +1.5V to +5.5V resulting in complementary output voltages of -1.5V to -5.5V. The ICL828 has a 12kHz internal oscillator and requires two capacitors to invert the supply voltage. Cascading may be made to increase the output voltage. The high efficiency (greater than 90% over most of the load-current range) and low operating current (60µA typical) make these devices ideal for both battery-powered and board-level voltage conversion applications.

Ordering Information

PART NUMBER	TEMP. RANGE (°C)	PACKAGE	PKG. NO	BRAND
ICL828IH-T	-40 to 85	5 Lead SOT23	P5.064	828

Block Diagram

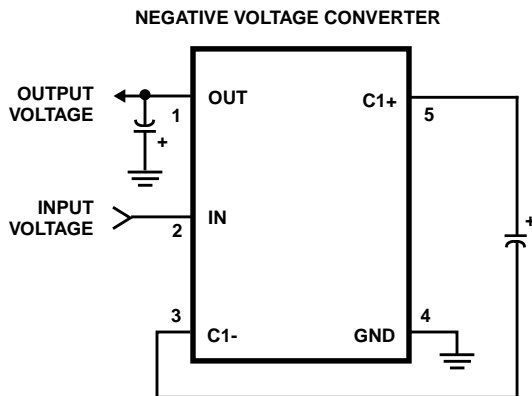

Features

- 5-Lead SOT23-5 Package
- 99% Open Circuit Voltage Conversion Efficiency
- Inverts Input Supply Voltage
- High Power Supply Efficiency
- Input Voltage Range +1.5V to +5.5V
- May be Cascaded to Increase Output Voltage
- Output Current 25mA
- Quiescent Current 60µA
- Pin for Pin Compatible to MAX828
- Small Package Size

Applications

- Simple Conversion +5V to -5V
- Voltage Multiplication $V_{OUT} = -nV_{IN}$
- Supply Splitter
 - Operational Amplifiers
 - Bias Supplies
- Hand Held Products
 - Cell Phones
 - PDAs
 - GPS
 - Pagers
- LCD Panels

Pinout

**ICL828 (SOT23)
TOP VIEW**

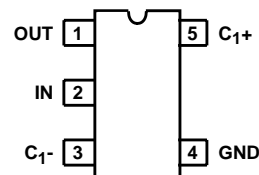

Absolute Maximum Ratings

IN to GND	+6.0V, -0.3V
OUT to GND	-6.0V, +0.3V
OUT Output CURRENT	50mA
OUT Short-circuit to GND	Indefinite

Operating Conditions

Temperature Range	-40°C to 85°C
Supply Voltage Range	1.5V to 5.5V

CAUTION: Stresses above those listed in "Absolute Maximum Ratings" may cause permanent damage to the device. This is a stress only rating and operation of the device at these or any other conditions above those indicated in the operational sections of this specification is not implied.

NOTE:

1. θ_{JA} is measured with the component mounted on a low effective thermal conductivity test board in free air. (See Tech Brief TB379 for details.).

Thermal Information

Thermal Resistance (Typical, Note 1)	θ_{JA} (°C/W)
SOT23 Package	240
Maximum Junction Temperature (Plastic Package)	150°C
Maximum Storage Temperature Range	-65°C to 150°C
Maximum Lead Temperature (Soldering 10s)	300°C

Electrical Specifications $V_{IN} = +5V, C_1 = C_2 = 10\mu F, T_A = -40^\circ C$ to $85^\circ C$, Unless Otherwise Specified

PARAMETER	SYMBOL	TEST CONDITIONS	MIN	TYP	MAX	UNITS
Supply Current	I_{CC}	25°C	-	60	90	μA
		-40°C to 85°C	-	-	115	μA
Minimum Supply Voltage	V_{CC}	$R_L = 10K, 25^\circ C$	1.25	1.0	-	V
		$R_L = 10K, -40^\circ C$ to $85^\circ C$	1.5	-	-	V
Maximum Supply Voltage	V_{CC}	$R_L = 10K$	-	-	5.5	V
Oscillator Frequency	f_{OSC}	-40°C to 85°C	6	-	20	kHz
Power Efficiency	P_{EFF}	$R_L = 10K, 25^\circ C$	-	98	-	%
Voltage Conversion Efficiency	V_{OUT} / V_{IN}	$R_L = Open$	95	99.9	-	%
Output Resistance	R_{OUT}	$I_{OUT} = 5mA, 25^\circ C$	-	20	50	Ω
		$I_{OUT} = 5mA, -40$ to $85^\circ C$	-	-	65	Ω

Typical Performance Curves

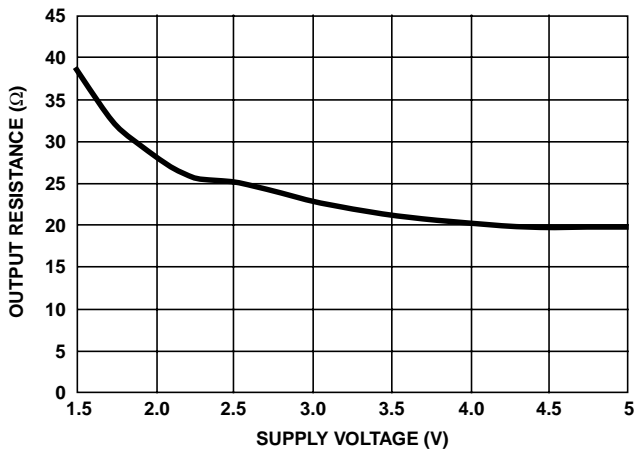

FIGURE 1. OUTPUT RESISTANCE vs SUPPLY VOLTAGE

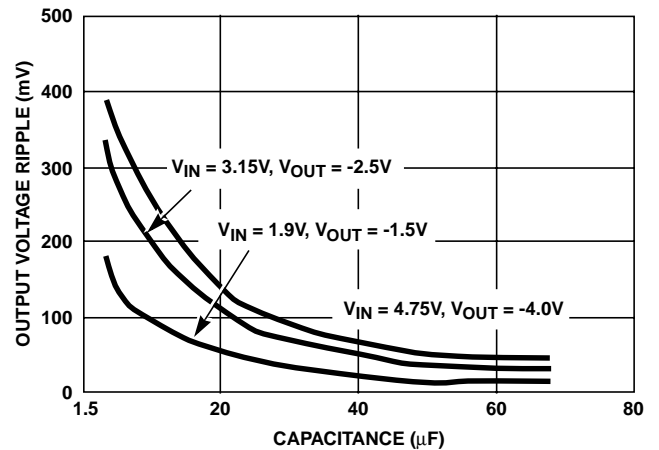

FIGURE 2. OUTPUT VOLTAGE RIPPLE vs CAPACITANCE

Typical Performance Curves (Continued)

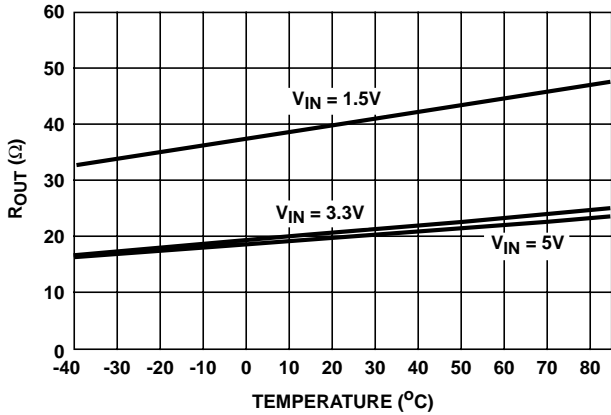

FIGURE 3. R_{OUT} vs TEMPERATURE

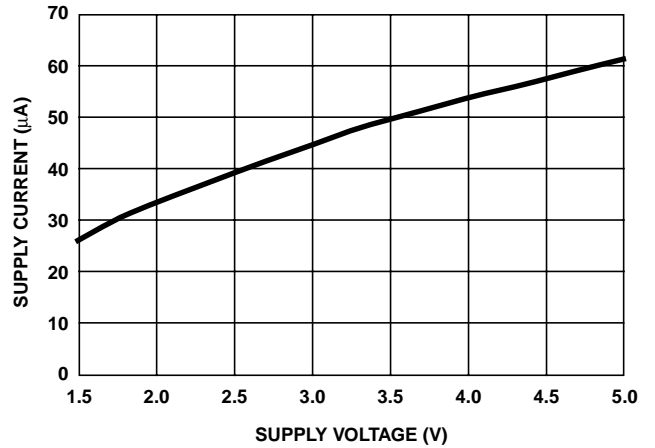

FIGURE 4. SUPPLY CURRENT vs VOLTAGE

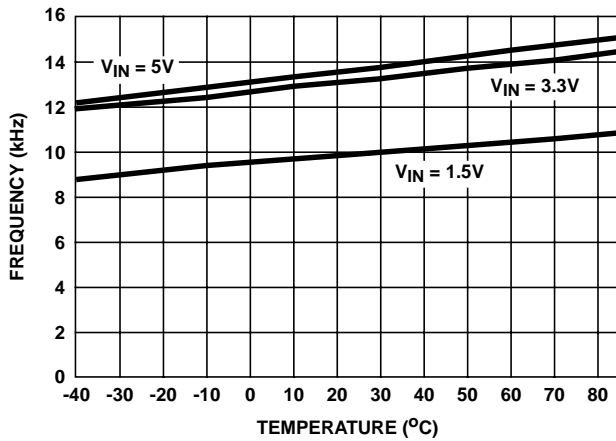

FIGURE 5. OSCILLATOR FREQUENCY vs TEMPERATURE

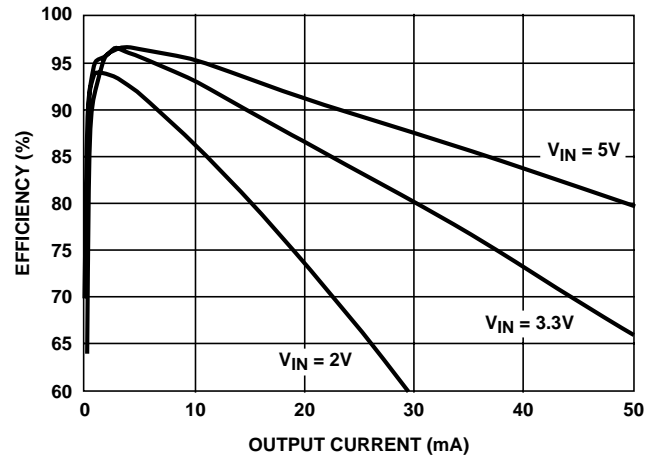

FIGURE 6. EFFICIENCY vs OUTPUT CURRENT

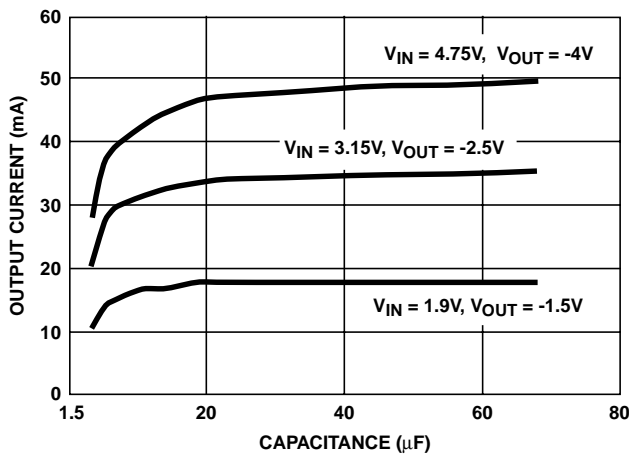

FIGURE 7. OUTPUT CURRENT vs CAPACITANCE

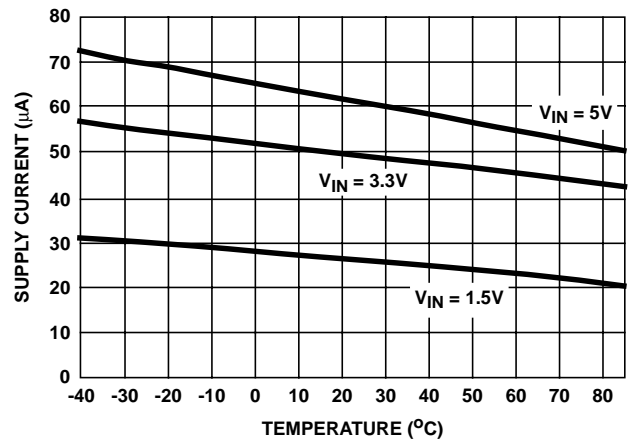
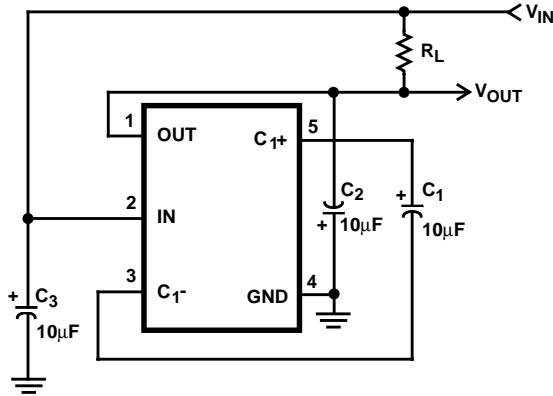

FIGURE 8. SUPPLY CURRENT vs TEMPERATURE

Test Circuit



NOTE: $V_{IN} = +5V$, $C_1 = C_2 = C_3$, $T_A = 25^\circ C$, unless otherwise noted.

FIGURE 9. TEST CIRCUIT

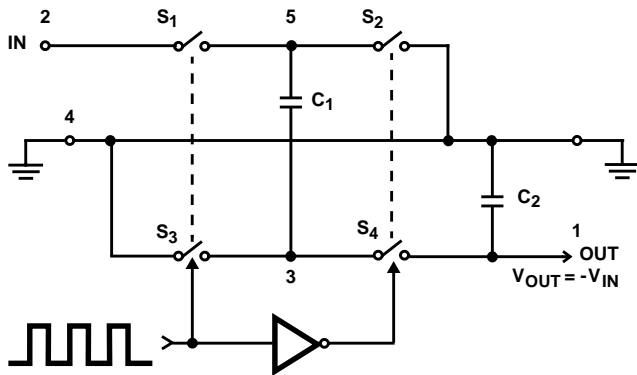

FIGURE 10. IDEALIZED NEGATIVE VOLTAGE CONVERTER

Description

The ICL828 contains all the necessary circuitry to complete a negative converter, utilizing two external inexpensive 10µF polarized electrolytic capacitor. The mode of operation of the device may be understood by considering Figure 10 which shows an idealized negative voltage converter.

Capacitor C_1 is charged to a voltage, V_{IN} , for the half cycle when switches S_1 and S_3 are closed (Note: switches S_2 and S_4 are open during this half cycle). During the second half cycle of operation, switches S_2 and S_4 are closed, with S_1 and S_3 open, thereby shifting capacitor C_1 negatively by V_{IN} Volts. Charge is then transferred from C_1 to C_2 such that the voltage on C_2 is exactly V_{IN} , assuming ideal switches and no load on C_2 .

Theoretical Power Efficiency Considerations

In theory a voltage converter can approach 100% efficiency if certain conditions are met:

1. The driver circuitry consumes minimal power.
2. The output switches have extremely low ON resistance and virtually no offset.

3. The impedances of the pump and reservoir capacitors are negligible at the pump frequency.

4. The losses due to the $1/f_C$ terms is small.

Energy is lost only in the transfer of charge between capacitors if a change in voltage occurs.

The energy lost is defined by:

$$E = \frac{1}{2}C_1(V_1^2 - V_2^2)$$

Where V_1 and V_2 are the voltages on C_1 during the pump and transfer cycles. If the impedances of C_1 and C_2 are relatively high at the pump frequency (refer to Figure 10) compared to the value of R_L , there will be a substantial difference in the voltages V_1 and V_2 . Therefore it is not only desirable to make C_2 as large as possible to eliminate output voltage ripple, but also to employ a correspondingly large value for C_1 in order to achieve maximum efficiency of operation.

Negative Voltage Converter

The output characteristics of the circuit on the first page can be approximated by an ideal voltage source in series with a resistance (Figure 11). The voltage source has a value of $-(V_{IN})$. The output impedance (R_O) is a function of the ON resistance of the internal MOS switches (shown in Figure 10), the switching frequency, the value of C_1 and C_2 , and the ESR (equivalent series resistance) of C_1 and C_2 . A good first order approximation for R_O is:

$$R_O = 2(R_{sw1} + R_{sw3} + ESR_{C1}) + 2(R_{sw2} + R_{sw4} + ESR_{C1}) + 1/(fpump)(C1) + ESR_{C2}$$

R_{sw} , the switch resistance, is a function of supply voltage and temperature (see Figure 3). Careful selection of capacitors will minimize the output resistance, and low capacitor ESR will lower the ESR term.

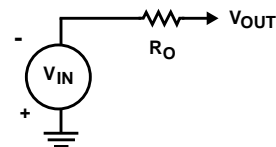

FIGURE 11. EQUIVALENT CIRCUIT

Output Ripple

ESR also affects the ripple voltage seen at the output. The total ripple is determined by 2 voltages, A and B, as shown in Figure 12. Segment A is the voltage drop across the ESR of C_2 at the instant it goes from being charged by C_1 (current flowing into C_2) to being discharged through the load (current flowing out of C_2). The magnitude of this current change is $2 \times I_{OUT}$, hence the total drop is $2 \times I_{OUT} \times ESR_{C2}$. Segment B is the voltage change across C_2 during time t_1 , the half of the cycle when C_2 supplies current the

load. The drop at B is $I_{OUT} \times t_1 / C_2 V$. The peak-to-peak ripple voltage is the sum of these voltage drops:

$$V_{RIPPLE} \cong \left(\frac{1}{2 \times C_2 \times f_{PUMP}} + 2 \text{ESRC}_2 \times I_{OUT} \right)$$

Again, a low ESR capacitor will result in a higher performance output.

Positive Voltage Doubling

The ICL828 may be employed to achieve positive voltage doubling using the circuit shown in Figure 13. In this application, the pump inverter switches of the ICL828 are used to charge C_1 to a voltage level of $V_{IN} - V_F$ where V_{IN} is the supply voltage and V_F is the forward voltage on C_1 plus the supply voltage (V_{IN}) is applied through diode D_2 to capacitor C_2 . The voltage thus created on C_2 becomes $(2V_{IN}) - (2V_F)$ or twice the supply voltage minus the combined forward voltage drops of diodes D_1 and D_2 .

The source impedance of the output (V_{OUT}) will depend on the output current.

Combined Negative Conversion and Positive Supply Doubling

Figure 14 combines the functions shown on front page and Figure 13 to provide negative voltage conversion and positive voltage doubling simultaneously. This approach would be, for example, suitable for generating +9V and -5V from an existing +5V supply. In this instance capacitors C_1 and C_3 perform the pump and reservoir functions respectively for the generation of the negative voltage, while capacitors C_2 and C_4 are pump and reservoir respectively for the doubled positive voltage. There is a penalty in this configuration which combines both functions, however, in that the source impedances of the generated supplies will be somewhat higher due to the finite impedance of the common charge pump driver at pin 2 of the device.

Cascading Devices

The ICL828 may be cascaded to produce a larger multiplication supply voltage (see Figure 15). The output voltage is:

$$V_{OUT} = -n(V_{IN}),$$

where n is an integer representing the number of devices cascaded.

The resulting output resistance would be approximately the sum of the individual ICL828 R_{OUT} values.

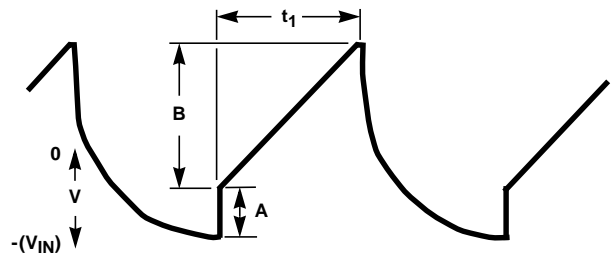
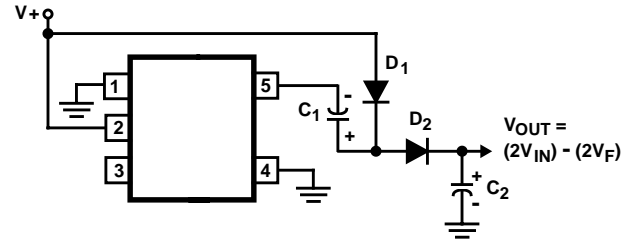

FIGURE 12. OUTPUT RIPPLE



NOTE: D_1 and D_2 can be any suitable diode.

FIGURE 13. POSITIVE VOLTAGE DOUBLER

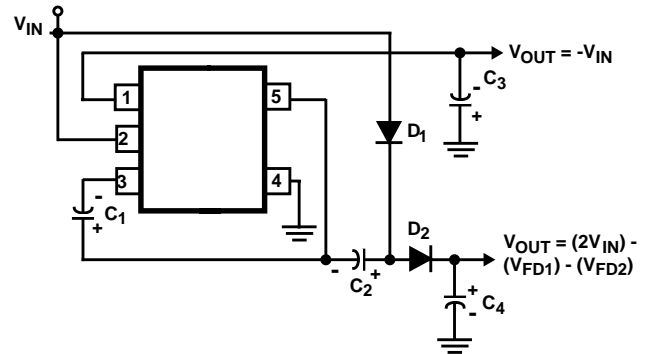

FIGURE 14. COMBINED NEGATIVE VOLTAGE AND POSITIVE DOUBLER

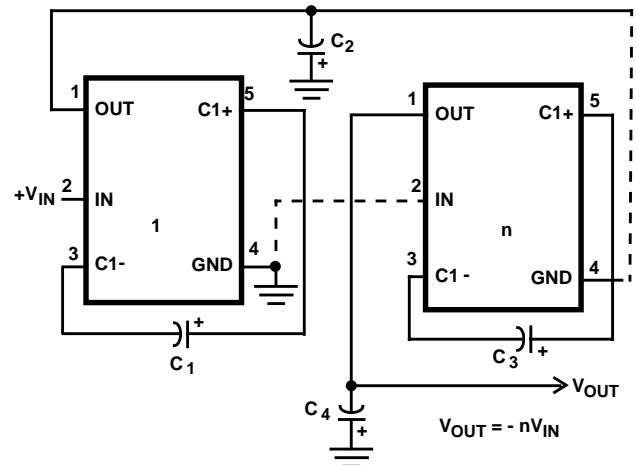

FIGURE 15. CASCADING TO INCREASE OUTPUT VOLTAGE

Voltage Splitting

The bidirectional characteristics of the switches of the ICL828 can be used to split a higher supply in half as shown below.

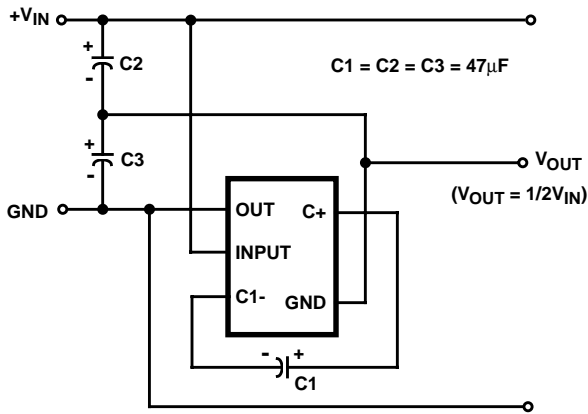

FIGURE 16. SPLIT SUPPLY APPLICATION

The combined load will be evenly shared between the two external capacitors because the switches share the load in parallel, the output resistance is approximately half of the standard voltage inverter.

Equivalent Circuit

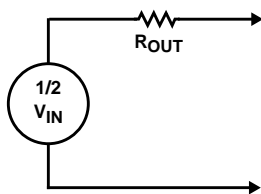

FIGURE 17.

Typical value for R_{OUT} in the above equivalent circuit would be 6Ω to 7Ω for an input voltage of 5V. The power efficiency for the circuit would be:

$$P_{EFF} = (I_{OUT} \cdot V_{OUT}) / ((1/2)(V_{IN} \cdot I_{OUT}) + (V_{IN} \cdot I_Q))$$

Typical values for ICL828 in this application,

$$I_Q = 22\mu A, R_{OUT} = 6\Omega \text{ to } 7\Omega$$

$$\text{and } V_{OUT} = 1/2 V_{IN} \cdot R_{LOAD} / (R_{OUT} + R_{LOAD}).$$

The ICL828 used as a voltage splitting circuit is an efficient means to providing a split supply application as shown in Figures 16 through 19.

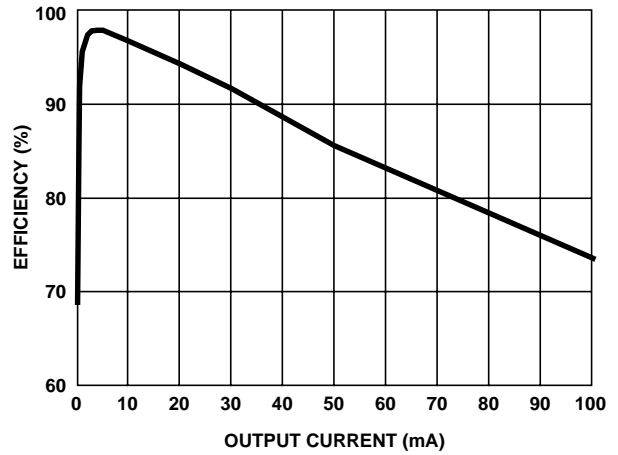

FIGURE 18. EFFICIENCY vs OUTPUT CURRENT FOR SPLIT SUPPLY APPLICATION

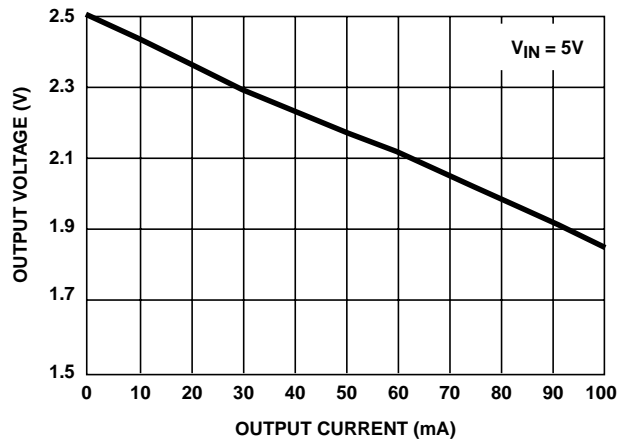
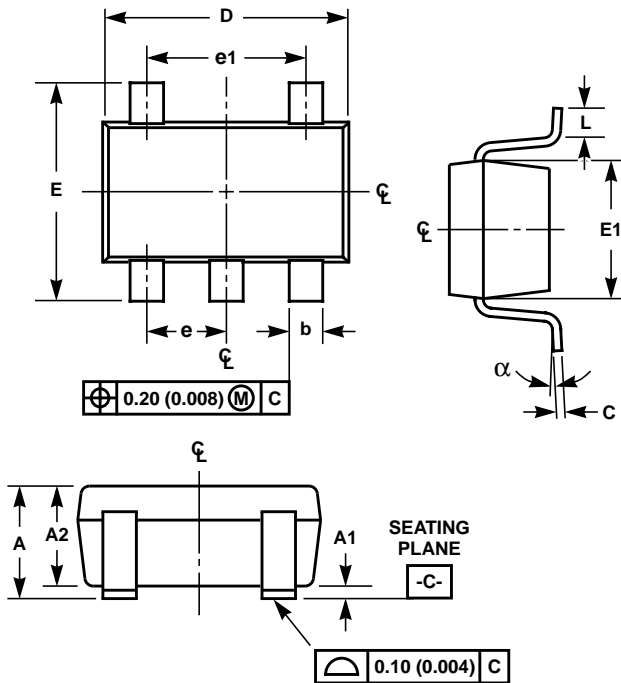

FIGURE 19. OUTPUT CURRENT vs OUTPUT VOLTAGE FOR SPLIT SUPPLY APPLICATIONS

Small Outline Transistor Plastic Packages (SOT23-5)



P5.064

5 LEAD SMALL OUTLINE TRANSISTOR PLASTIC PACKAGE

SYMBOL	INCHES		MILLIMETERS		NOTES
	MIN	MAX	MIN	MAX	
A	0.036	0.057	0.90	1.45	-
A1	0.000	0.0059	0.00	0.15	-
A2	0.036	0.051	0.90	1.30	-
b	0.0138	0.0196	0.35	0.50	-
C	0.0036	0.0078	0.09	0.20	-
D	0.111	0.118	2.80	3.00	3
E	0.103	0.118	2.60	3.00	-
E1	0.060	0.068	1.50	1.75	3
e	0.0374 Ref		0.95 Ref		-
e1	0.0748 Ref		1.90 Ref		-
L	0.004	0.023	0.10	0.60	4, 5
N	5		5		6
α	0°	10°	0°	10°	-

Rev. 0 10/98

NOTES:

1. Dimensioning and tolerances per ANSI 14.5M-1982.
2. Package conforms to EIAJ SC-74A (1992).
3. Dimensions D and E1 are exclusive of mold flash, protrusions, or gate burrs.
4. Footlength L measured at reference to seating plane.
5. "L" is the length of flat foot surface for soldering to substrate.
6. "N" is the number of terminal positions.
7. Controlling dimension: MILLIMETER. Converted inch dimensions are not necessarily exact.

All Intersil semiconductor products are manufactured, assembled and tested under **ISO9000** quality systems certification.

Intersil semiconductor products are sold by description only. Intersil Corporation reserves the right to make changes in circuit design and/or specifications at any time without notice. Accordingly, the reader is cautioned to verify that data sheets are current before placing orders. Information furnished by Intersil is believed to be accurate and reliable. However, no responsibility is assumed by Intersil or its subsidiaries for its use; nor for any infringements of patents or other rights of third parties which may result from its use. No license is granted by implication or otherwise under any patent or patent rights of Intersil or its subsidiaries.

For information regarding Intersil Corporation and its products, see web site www.intersil.com

Sales Office Headquarters

NORTH AMERICA
 Intersil Corporation
 P. O. Box 883, Mail Stop 53-204
 Melbourne, FL 32902
 TEL: (321) 724-7000
 FAX: (321) 724-7240

EUROPE
 Intersil SA
 Mercure Center
 100, Rue de la Fusee
 1130 Brussels, Belgium
 TEL: (32) 2.724.2111
 FAX: (32) 2.724.22.05

ASIA
 Intersil Ltd.
 8F-2, 96, Sec. 1, Chien-kuo North,
 Taipei, Taiwan 104
 Republic of China
 TEL: 886-2-2515-8508
 FAX: 886-2-2515-8369