

FEATURES

- Very low LO requirement: -10dBm
- 34 dB Gain Control Range
- Excellent I/Q Amplitude and Phase Balance (± 0.3 dB & ± 2 Degrees respectively)
- High Output P1dB: +10 dBm
- 29 dB Gain (High Gain Mode)
- Low Current Consumption: 140 mA

APPLICATIONS

- Cellular, PCS, DCS, GSM, UMTS Transceivers
- ISM Band Transceivers - WLAN - IEEE 802.11, Bluetooth
- ISO/EPC Compliant UHF RFID Readers
- Fixed Wireless Infrastructure, Wireless Local Loop

OVERVIEW

The ICQ2716 is a single chip, broadband quadrature demodulator RFIC designed for UHF and microwave receiver IF applications. It is used to recover the I and Q baseband signals from IF. The device features excellent I/Q amplitude and phase balance, high P1dB and a wide gain control range making it suitable for low noise receiver applications.

The device carries a variable gain amplifier (VGA) and an I/Q demodulator with a phase shifter and frequency divider.

The IC is available in industry standard 16L-TSSOP and 16L-SLP packages with exposed paddle for providing a good RF and thermal ground.

FUNCTIONAL BLOCK DIAGRAM

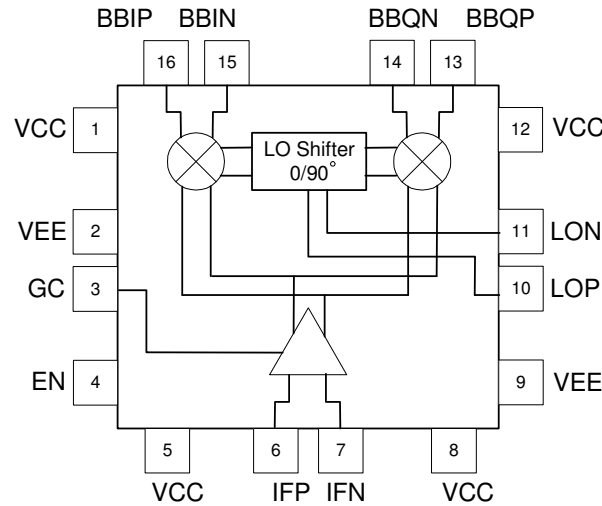

PACKAGE

16-L SLP / 16-L TSSOP

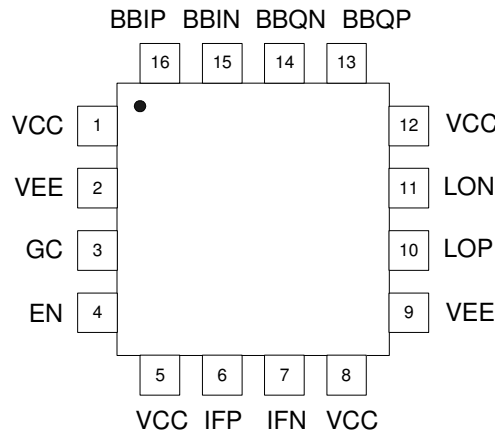

PIN OUT DESCRIPTION

Pin #	Symbol	Description
1	V _{CC}	Positive Power Supply
2	V _{EE}	Ground
3	GC	Gain Control Input; 5V CMOS level
4	EN	Enable
5	V _{CC}	Positive Power Supply
6	IFP	IF Input Positive (+); self-biasing, AC coupled
7	IFN	IF Input Negative (-); self-biasing, AC coupled
8	V _{CC}	Positive Power Supply
9	V _{EE}	Ground
10	LOP	Positive Local Oscillator (LO) input; self-biasing, AC coupled
11	LON	Negative Local Oscillator (LO) input; self-biasing, AC coupled
12	V _{CC}	Positive Power Supply
13	BBQP	Baseband Q Output (Positive +)
14	BBQN	Baseband Q Output (Negative -)
15	BBIN	Baseband I Output (Negative -)
16	BBIP	Baseband I Output (Positive +)

ABSOLUTE MAXIMUM RATING

Symbol	Parameter	Value	Unit
V _{CC}	Positive Power Supply	6.0	V _{DC}
LO	LO Input Power	+10	dBm
IF	IF Input Power	+10	dBm
T _{OP}	Operating Temperature	-40 to +85	°C
T _{STG}	Storage Temperature	-65 to +150	°C
T _{SOL}	Soldering Temperature	300	°C

Note: Stress greater than those listed above may cause permanent damage to the device. This is a stress rating only and functional operation of the device at these or any other conditions above those indicated in the operational sections of this specification is not implied. Exposure to absolute maximum rating conditions for extended periods may affect reliability.

ORDERING INFORMATION

Part	Temperature Range	Package
ICQ2716	-40°C to 85°C	16-L SLP
ICQ2716	-40°C to 85°C	16-L TSSOP

TEST CONDITIONS

V _{CC} = +5 V _{DC} , T = +25°C, LO input = -10 dBm, 400 MHz, IF Input = 400.1 MHz		
Gain State	Gain Control (GC)	IF Power
Low Gain	+0.56V	0 dBm
Medium Gain	+1.3V	-20 dBm
High Gain	+4V	-40 dBm

Unless otherwise stated, measurements were done on the evaluation board



Caution! ESD Sensitive Device

Appropriate precaution in handling, packaging and testing must be observed

PRODUCT SPECIFICATIONS

Parameter	Test Conditions	Min	Typ	Max	Unit
Supply Voltage		+4.75	+5.0	+5.25	V
Supply Current		136	140	144	mA

Parameter	Test Conditions	Min	Typ	Max	Unit
IF/LO Frequency Range	(See Page 2)	200	350-550	600	MHz
Conversion Gain	(See Page 2)		-5/15/29		dB
Gain Tuning Range	(See Page 2)		34		dB
Input P1dB	(See Page 2)		-5/-12/-19		dBm
I/Q Output Frequency Range	(See Page 2)	0.05		80	MHz
I/Q Output Amplitude Balance	(See Page 2)	-0.3		+0.3	dB
I/Q Output Phase Balance	(See Page 2)	-0.2		+0.2	Deg
Noise Figure (NF)	(See Page 2)		12		dB

PRODUCT SPECIFICATIONS – IF Input (I/Q Mixing to Baseband)

Parameter	Test Conditions	Min	Typ	Max	Unit
Frequency Range		200	350-550	600	MHz
Return Loss	50Ω reference		18.7		dB
Gain	High Gain Setting (GC = +4V)		+29		dB
Input P1dB			-19		dBm
Noise Figure			12		dB
Gain	Medium Gain Setting (GC = +1.3V)		+15		dB
Input P1dB			-12		dBm
Gain	Low Gain Setting (GC = +0.56V)		-5		dB
Input P1dB			-5		dBm

PRODUCT SPECIFICATIONS – I/Q Output

Parameter	Test Conditions	Min	Typ	Max	Unit
I/Q Output Frequency Range		0.05		80	MHz
I/Q Output Amplitude Balance		-0.3		+0.3	dB
I/Q Output Phase Balance		-0.2		+0.2	Deg
I/Q Output Common-Mode Voltage		+0.009	+2.4	+2.5	V

PRODUCT SPECIFICATIONS – LO Input

Parameter	Test Conditions	Min	Typ	Max	Unit
LO Input Level		-20	-10	0	dBm
Return Loss (Ports: IF/LO)	10 MHz 500 MHz		18.8 11.3		dB

Gain VS Pin, High Gain Mode

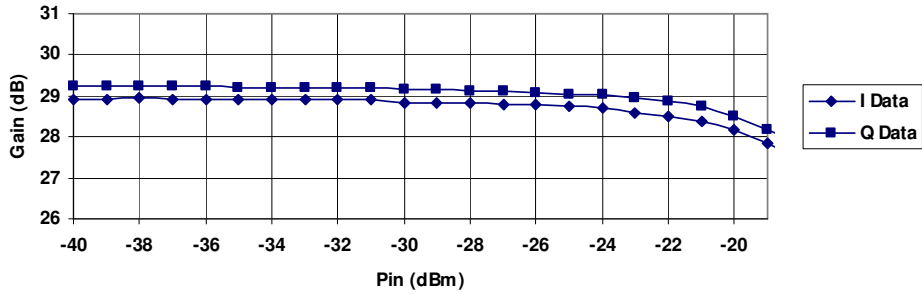

Gain VS Pin, Medium Gain Mode

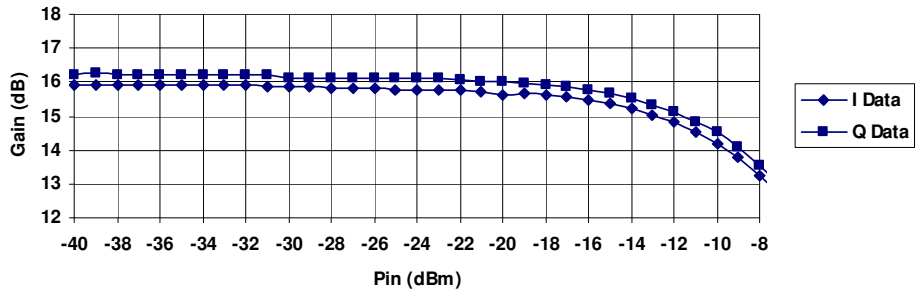

Gain VS Pin, Low Gain Mode

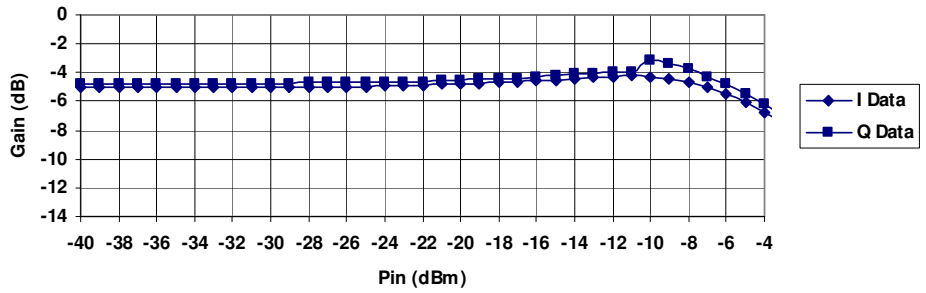

I/Q Amplitude Balance

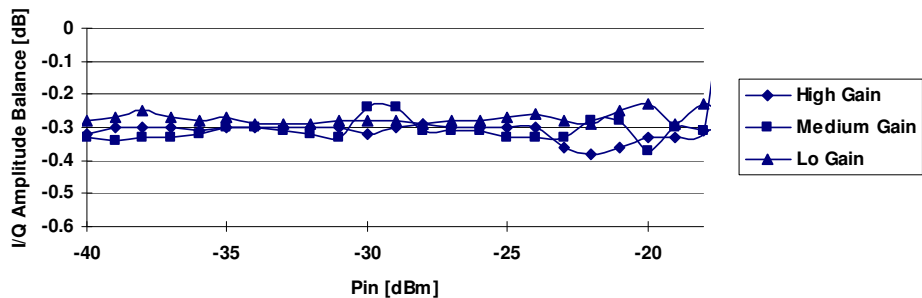

EVALUATION BOARD SCHEMATIC

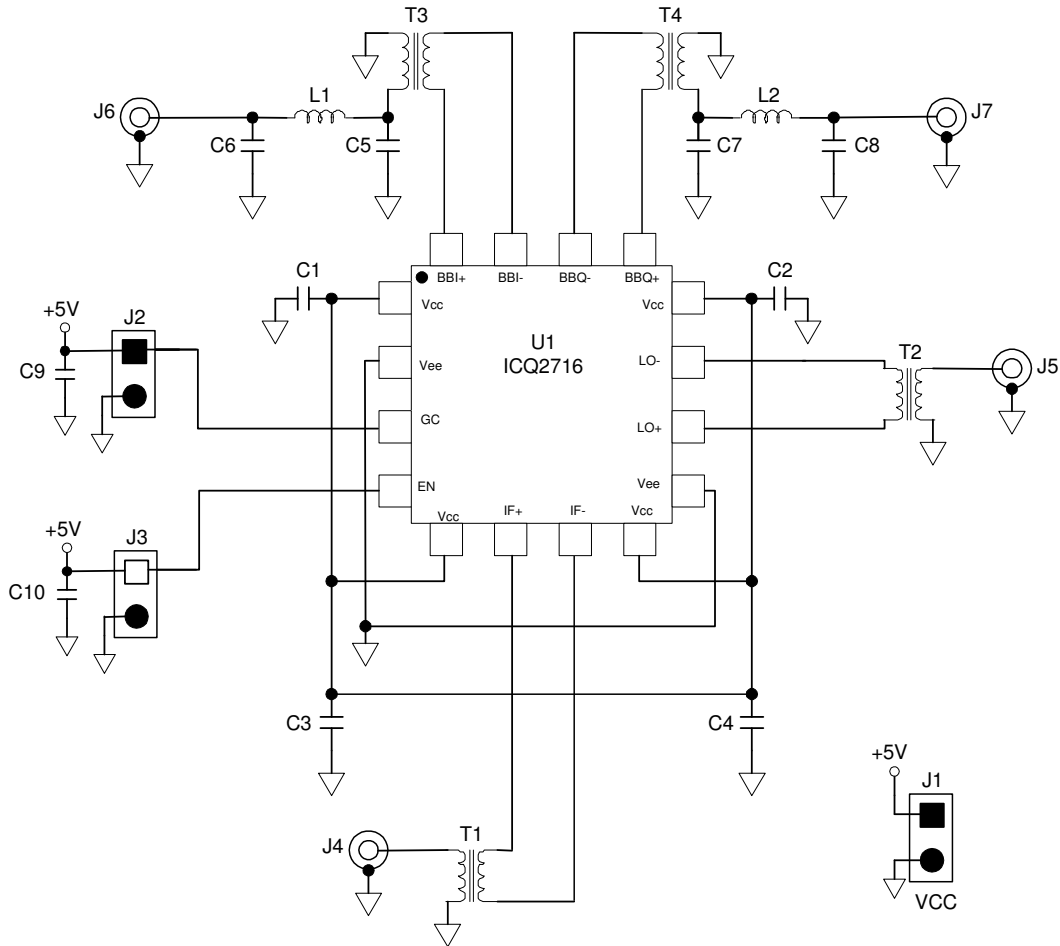

TEST PCB

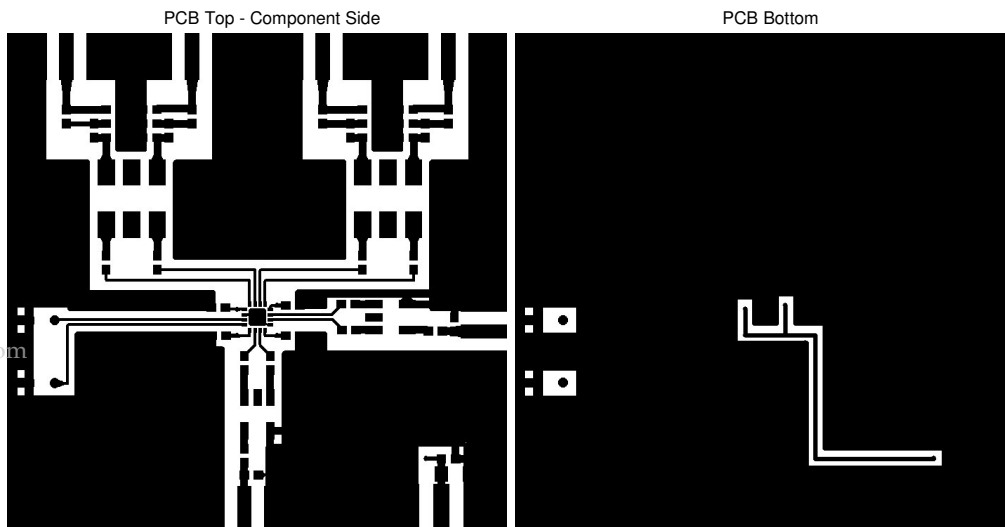

www.DataSheet4U.com

FULLY ASSEMBLED PCB

ICQ2716-EVAL

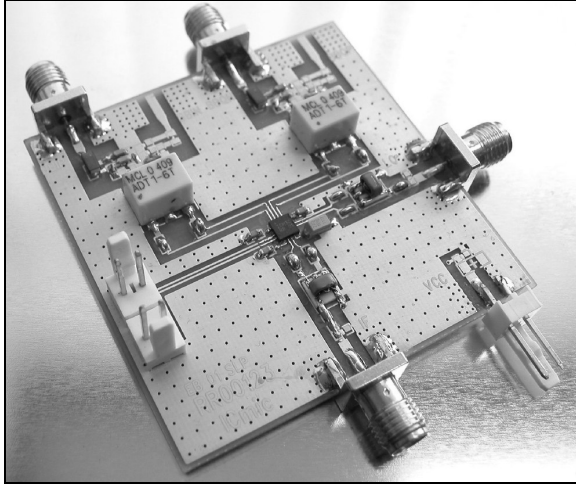

PCB COMPONENTS

Component Designator	Value	Qty	Description
U1		1	ICQ2716 IF Receiver
J1, J2, J3		3	2 Pin Header (VCC, GC, EN)
J4, J5, J6, J7		4	SMA End Launch Connectors
T1, T2		2	IF Transformers
T3, T4		2	Baseband Transformers
C1, C3	470 pF	2	Bypass Capacitors
C2	18 pF	1	Bypass Capacitor
C4	2.2 uF	1	Bypass Capacitor
C5, C6, C7, C8	470 pF	4	Filter Capacitors
C9, C10	2.2 uF	2	Bypass Capacitors
L1, L2	560 nH	2	Filter Inductors

PACKAGE DIAGRAM

16L-SLP

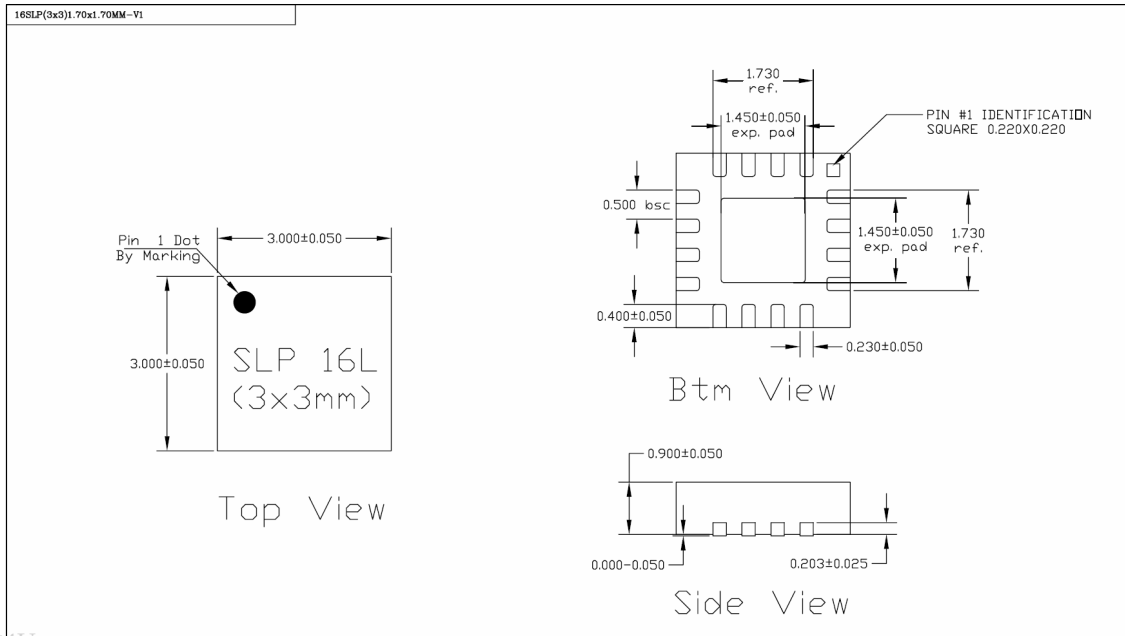

www.DataSheet4U.com