



Overview

The **ICS1522** is ideally suited to provide the graphics system clock signals required by high-performance video DACs. Fully programmable feedback and reference divider capability allow virtually any frequency to be generated, not just simple multiples of the reference frequency. The **ICS1522** uses the latest generation of frequency synthesis techniques developed by ICS and is completely suitable for the most demanding video applications.

PLL Synthesizer Description - Ratiometric Mode

The **ICS1522** generates its output frequencies using phase-locked loop techniques. The phase-locked loop (or PLL) is a closed-loop feedback system that drives the output frequency to be ratiometrically related to the reference frequency provided to the PLL (see Block Diagram). The reference frequency is generated by an on-chip crystal oscillator or the reference frequency may be applied to the **ICS1522** from an external frequency source, typically horizontal sync from another display system.

The phase-frequency detector shown in the Block Diagram drives the voltage-controlled oscillator, or VCO, to a frequency that will cause the two inputs to the phase-frequency detector to be matched in frequency and phase. This occurs when:

$$F(\text{VCO}) = \frac{F(\text{XTAL1}) \cdot \text{Feedback Divider}}{\text{Reference Divider}}$$

This expression is exact; that is, the accuracy of the output frequency depends solely on the reference frequency provided to the part (assuming correctly programmed dividers).

The VCO gain is programmable, which permits the **ICS1522** to be optimized for best performance at all operating frequencies.

The feedback divider may be programmed for any modulus from 64 to 2048 in steps of one followed by a divide by 1, 2, 4 or 8 feedback post-scaler.

The reference divider may be programmed for any modulus from 1 to 1024 in steps of one.

Output Post-scaler

A programmable post-scaler may be inserted between the VCO and the CLK+ and CLK- outputs of the **ICS1522**. This is useful in generating of lower frequencies, as the VCO has been optimized for high-frequency operation.

The post-scaler allows the selection of dividing the VCO frequency by either 1, 2, 4 or 8.

Load Clock Divider

The **ICS1522** has an additional programmable divider (referred to in the Block Diagram as the load counter) that is used to generate the LOAD clock frequency for the video DAC. The modulus of this divider may be set to 3, 4, 5, 6, 8, or 10 under register control. The design of this divider permits the output duty factor to be 50/50, even when odd modulus is selected. The input frequency to this divider is the output of the output post-scaler described above.

Digital Inputs - ICS1522

The programming of the **ICS1522** is performed serially by using the **SDATA**, **SCLK**, and **SELn** pins to load the 7, 11 bit internal memory locations.

Single bit changes are accomplished by addressing the appropriate memory location and writing only 11 bits of data, not by writing all 77 data bits.

For proper programming of the **ICS1522**, it is important that all transitions of the **SELn** input occur during the same state of the **SCLK** input.

SDATA is shifted into a 15 bit serial register on the rising edge of **SCLK** while **SELn** is low. The first bit loaded is R/Wn followed by a 3 bit address and 11 bit data (both address & data are LSB first). When a rising edge of **SCLK** occurs while **SELn** is high (**SDATA** ignored), the contents of the serial register are loaded into the addressed 11 bit memory location if R/Wn is low. If R/Wn is high upon the above condition, the data from the addressed memory location is loaded into the serial shift register and **SDATA** is set as an output. The 3 bit address and 11 bit data will be serially shifted out of the **ICS1522** on the **SDATA** pin on the rising edge of **SCLK** while **SELn** is low (see Timing Diagram).

An additional control pin on the **ICS1522**, **PDEN** can be used to disable the phase-frequency detector in line-locked applications. When disabled, the phase detector will ignore any inputs and allow the VCO to coast. This feature is useful in systems using composite sync.

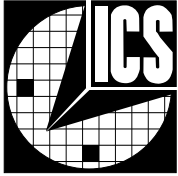

Output Description

The differential output drivers, **CLK+** and **CLK-**, are current-mode and are designed to drive resistive terminations in a complementary fashion. The outputs are current-sinking only, with the amount of sink current programmable via the **IPRG** pin. The sink current, which is steered to either **CLK+** or **CLK-**, is four times the current supplied to the **IPRG** pin. For most applications, a resistor from **VDDO** to **IPRG** will set the current to the necessary precision.

Reference Oscillator and Crystal Selection

The **ICS1522** has circuitry on-board to implement a Pierce oscillator with the addition of a quartz crystal and two external loading capacitors (**EXTREF** bit must be set to logic 0). Pierce oscillators operate the crystal in anti- (also called parallel-) resonant mode.

Series-resonant crystals may also be used with the **ICS1522**. Be aware that the oscillation frequency will be slightly higher than the frequency that is stamped on the can (typically 0.025-0.05%).

As the entire operation of the phase-locked loop depends on having a stable reference frequency, we recommend that the crystal be mounted as closely as possible to the package. Avoid routing digital signals or the **ICS1522** outputs underneath or near these traces. It is also desirable to ground the crystal can to the ground plane, if possible. If an external reference frequency source is to be used with the **ICS1522**, it is important that it be jitter-free. The rising and falling edges of that signal should be fast and free of noise for best results. The loop phase is locked to the rising edge of the **XTAL1/EXTREF** input signal, if **REF_POL** is set to logic 0. Additionally, the **EXTREF** bit should be set to logic 1 to switch in a TTL-compatible buffer at this input.

24-Pin SOIC

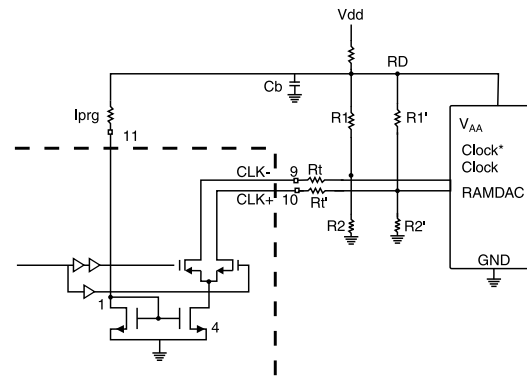
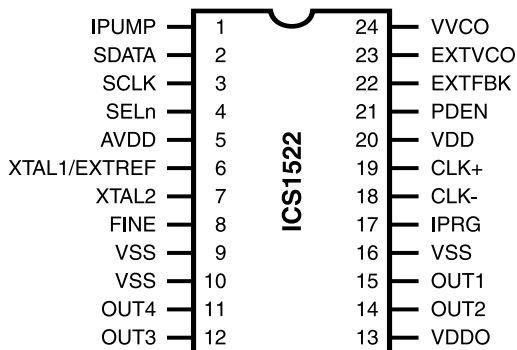

Line-Locked Operation

Some video applications require a clock to be generated that is a multiple of horizontal sync. The **ICS1522** supports this mode of operation. The reference divider should be set to divide by one and the desired polarity (rising or falling) of lock edge should be selected. By using the phase detector hardware disable mode (**PDEN**), the PLL can be made to free-run at the beginning of the vertical interval of the external video, and can be reactivated at its completion.

External Feedback Operation

The **ICS1522** option also supports the inclusion of an external counter as the feedback divider of the PLL. This mode is useful in graphic systems that must be “genlocked” to external video sources.

When the **FBK_SEL** bit is set to logic 0, the phase-frequency detector will use the **EXTFBK** pin as its feedback input. The loop phase will be locked to the rising edges of the signal applied to the **EXTFBK** input if **FBK_POL** is set to logic 0. Synchronous switchover to the internal feedback can be accomplished by setting the **FBK-SEL** bit to logic 1 while an active feedback source exists on the **EXTFBK** pin.

Fine Phase Adjustment

The **ICS1522** has the capability of adjusting the pixel clock phase relative to the input reference phase. Entire pixels can be added or removed under register control with sub-pixel adjustment accomplished by a control voltage on the **FINE** input pin. By utilizing the fine phase adjust, after first synchronously switching from external feedback to internal feedback, the graphics system phase can be precisely controlled relative to the input horizontal sync.

ICS1522

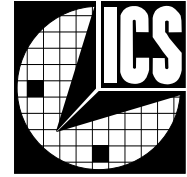

Power-On Initialization

The **ICS1522** has an internal power-on reset circuit that sets the frequency of the CLK+ and CLK- outputs to be half the crystal or reference frequency assuming that they are between 10 MHz and 25 MHz (refer to default settings in Register Definition). Because the power-on reset circuit is on the VDD supply, and because that supply is filtered, care must be taken to allow the reset to de-assert before programming. A safe guideline is to allow 20 microseconds after the VDD supply reaches four volts.

Board Test Support

It is often desirable to statically control the levels of the output pins for circuit board test. The **ICS1522** supports this through a register programmable mode, AUXEN. When this mode is set, AUXCLK will directly control the logic levels of the CLK+ and CLK- pins while OMUX1, OMUX2, OMUX3, and OMUX4 will control OUT1, OUT2, OUT3 and OUT4, respectively.

Pin Discriptions

PIN NUMBER	PIN NAME	TYPE	DESCRIPTION
1	IPUMP	OUT	Charge Pump output (External loop filter applications)
2	SDATA	IN/OUT	Serial Data Input/Output
3	SCLK	IN	Serial Clock Input
4	SELn	IN	Serial Port enable (active Low)
5	AVDD	PWR	Analog +5 Volt Supply
6	XTAL1/EXTREF	IN	External Reference Input / Xtal Oscillator Input
7	XTAL2	OUT	Xtal Oscillator Output
8	FINE	IN	Fine Phase Adjust Input
9	VSS	PWR	Ground
10	VSS	PWR	Ground
11	OUT4	OUT	Output 4
12	OUT3	OUT	Output 3
13	VDDO	PWR	Output Driver +5 Volt Supply
14	OUT2	OUT	Output 2
15	OUT1	OUT	Output 1
16	VSS	PWR	Ground
17	IPRG	IN	Output Driver Current Programming Input
18	CLK-	OUT	Differential CLK - Output
19	CLK+	OUT	Differential CLK + Output
20	VDD	PWR	Digital +5 Volt Supply
21	PDEN	IN	Phase Detector Enable (Active High)
22	EXTFBK	IN	External Feedback Input
23	EXTVCO	IN	External VCO input
24	VVCO	IN	VCO Control Voltage Input (External loop filter applications)

Power Supplies and Decoupling

The **ICS1522** has three VSS pins to reduce the effects of package inductance. Both pins are connected to the same potential on the die (the ground bus). These pins should connect to the ground plane of the video board as close to the package as is possible.

The **ICS1522** has a VDDO pin which is the supply of +5 volt power to all output drivers. This pin should be connected to the power plane (or bus) using standard high-frequency decoupling practice. That is, capacitors should have low series inductance and be mounted close to the **ICS1522**. The VDD pin is the power supply pin for the PLL synthesizer circuitry and other lower current digital functions. We recommend that RC decoupling or zener regulation be provided for this pin (as shown in the recommended application circuitry). This will allow the PLL to “track” through power supply fluctuations without visible effects.

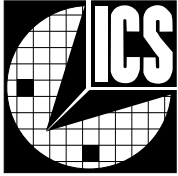

ICS1522 Register Definition

REG#	BIT(S)	BIT REF.	DESCRIPTION
0	0-10	F[0:10]	Feedback Divider (Default=04F, Modulus=80) Divides the VCO by the set modulus Modulus Range=64 to 2048; Modulus=Value+1
1	0-7	LO[0:7]	Feedback Sync Pulse LO (Default=03) Feedback Divider output, but with programmable phase; LO[0:7] <F[3:10].
2	0-7	HI[0:7]	Feedback Sync Pulse HI (Default=06) Feedback Divider output, but with programmable phase; HI[0:7] <F[3:10].
3	0-9	R[0:9]	Reference Divider (Default=013, Modulus=20) Divides the XTAL/EXTREF by the set modulus Modulus Range=1 to 1024; Modulus=Value+1
3	10	REF_POL	External Reference Polarity (Default=0) 0=Positive Edge; 1=Negative Edge
4	0-2	VCO[0:2]	VCO Gain (Default=4)

VCO(2)	VCO(1)	VCO(0)	VCO GAIN
0	0	0	10 MHz/V
0	0	1	15 MHz/V
0	1	0	20 MHz/V
0	1	1	25 MHz/V
1	0	0	45 MHz/V
1	0	1	60 MHz/V
1	1	0	75 MHz/V
1	1	1	90 MHz/V



REG#	BIT(S)	BIT REF.	DESCRIPTION
4	3-5	PFD (0;2)	Phase Frequency Detector Gain

PFD(2)	PFD(1)	PFD(0)	PFD GAIN	FINE PHASE ADJ.
0	0	0	.2344uA/2πrad	3ns/V
0	0	1	.9375uA/2πrad	3ns/V
0	1	0	3.750uA/2πrad	3ns/V
0	1	1	15.00uA/2πrad	3ns/V
1	0	0	1.875uA/2πrad	6ns/V
1	0	1	7.500uA/2πrad	6ns/V
1	1	0	30.00uA/2πrad	1.5ns/V
1	1	1	120.0uA/2πrad	.375ns/V

4	6	PDEN	Phase Frequency Detector Enable (Default=1) 0=PFDDisable; 1=PFDEnable
4	7	INT_FLT	Loop Filter Select (Default=1) 0=External Loop Filter (IPUMP & VVCO active) 1=Internal Loop Filter
4	8	INT_VCO	VCO Select (Default=1) 0=External VCO (EXTVCO active) 1=Internal VCO
4	9	CLK_SEL	Feedback Divider Clock Input Select (Default=0) 0=VCO; 1=OUT1
4	10	RESERVED	Must be set to one.
5	0	FBK_SEL	Feedback Select (Default=1) 0=External Feedback (EXTFBK active) 1=Internal Feedback An active external feedback signal at EXTFBK is necessary to synchronously switch to internal.
5	1	FBK_POL	External Feedback Polarity (Default=0) 0=Positive Edge; 1=Negative Edge
5	2	ADD	Addition of 1 VCO Cycle (Default=0) Toggle (0 to 1 to 0) to add 1 VCO cycle.
5	3	SWLW	Removal of 1 VCO Cycle (Default=0) Toggle (0 to 1 to 0) to remove 1 VCO cycle.

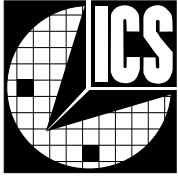

REG# 5 BIT(S) 4-5 BIT REF. PDA(0:1) DESCRIPTION Output Post-scaler (Default=0)
Input=VCO; Output = Differential Output

PFD(2)	PFD(0)	DIVIDE BY
0	0	8
0	1	4
1	0	2
1	1	1

5 6-7 PDB(0:1) Feedback Post-scaler (Default=3)
Input=Feedback Divider; Output=PFD

PDB(1)	PDB(0)	DIVIDE BY
0	0	8
0	1	4
1	0	2
1	1	1

5 8 LD_LG Fine Phase Adjust Lead/Lag (Default=1)
1=FBK will lag REF at input to PFD
0=FBK will lead REF at input to PFD

5 9 F_EN Fine Phase Adjust Enable (Default=)
0=Disable; 1=Enable

5 10 RESERVED Must be set to one.

6 0-2 L(0:2) Load Counter (Default=7)

L(2)	L(1)	L(0)	DIVIDE BY
0	0	0	31-pos, 0-neg
0	0	1	4 pos edge
0	1	0	4 neg edge
0	1	1	51-neg, 0-pos
1	0	0	6 pos edge
1	0	1	8 neg edge
1	1	0	8 neg edge
1	1	1	10 neg edge



REG#	BIT(S)	BIT REF.	DESCRIPTION
6	3	OMUX1	OUT1 Select (Default=0) 0=Load Counter Output 1=Diff. Output Divided by 4 at 0 Degrees OUT1 will track OMUX1 when AUXEN=1
6	4	OMUX2	OUT2 Select (Default=0) 0=Internal Feedback Pulse 1=Diff. Output Divided by 4 at 90 Degrees OUT2 will track OMUX2 when AUXEN=1\
6	5	OMUX3	OUT3 Select (Default=0) 0=Feedback Sync Pulse LO 1=Diff. Output Divided by 4 at 180 Degrees OUT3 will track OMUX3 when AUXEN=1
6	6	OMUX4	OUT4 Select (Default=1) 0=Feedback Sync Pulse HI 1=Diff. Output Divided by 4 at 270 Degrees OUT4 will track OMUX4 when AUXEN=1
6	7	DACRST	Output Reset (Default=0) When set to one, the CLK+ output is kept high and the CLK-output is kept low. When returned to zero, the CLK+ and CLK-outputs will resume toggling on a rising edge of the OUT1 output (programmed for Load Counter) within +/- 1 clock period.
6	8	AUXEN	Output Test Mode (Default=0) 0=Normal Output Operation 1=Output Test Mode (see OMUX1-4 and AUXCLK)
6	9	AUXCLK	Output Clock when in Test Mode (Default=0) CLK+ and CLK- will track AUXCLK when AUXEN=1
6	10	EXTREF	XTAL/EXTREF Input Buffer (Default=0) 0=Crystal Input Operation 1=External Reference Input Operation

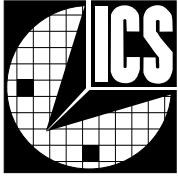

Serial Programming Timing Diagram

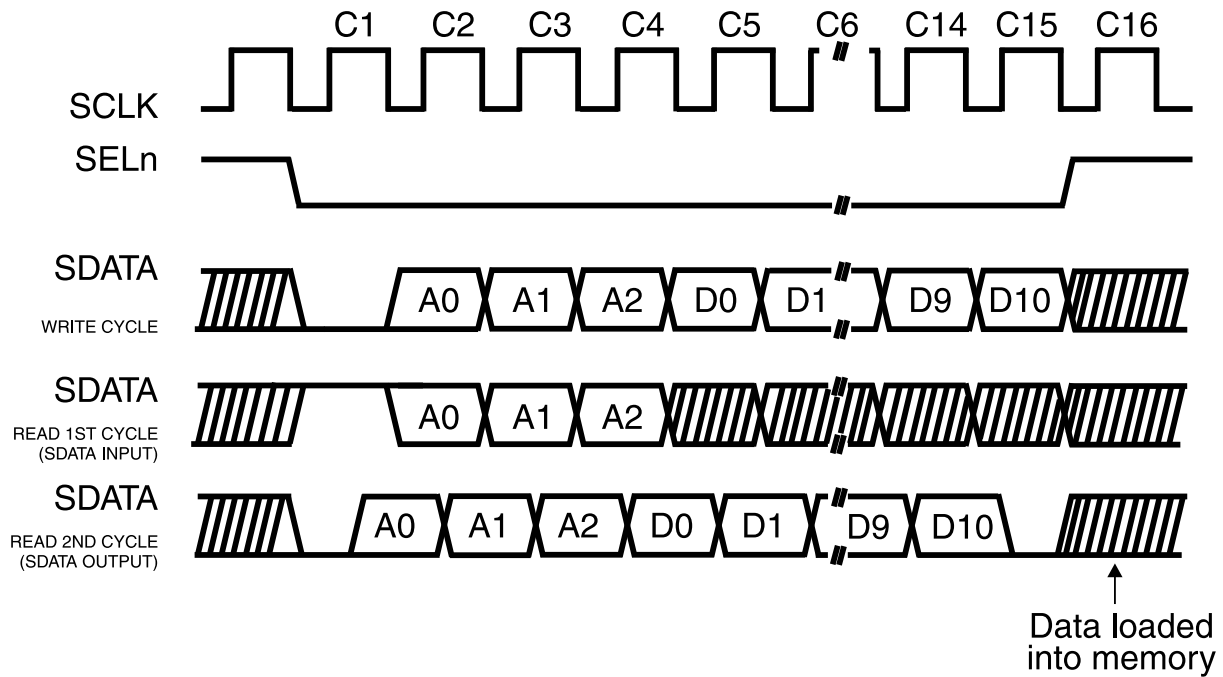

NOTES:

1. R/Wn, READ=1 and WRITE=0
2. Address and data transmitted least significant bit first
3. 16 Positive-edge clocks required for complete data read/write (1-R/Wn, 3-Address, 11-Data, and 1 load data W/SELn HIGH)
4. SELn's positive and negative transitions must occur on the same state of SCLK
5. An ICS1522 read consists of two consecutive cycles (1st cycle - SDATA is an input, 2nd cycle - SDATA is an output)

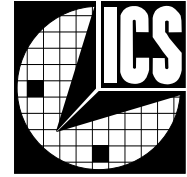

Absolute Maximum Ratings

VDD, VDDO (measured to VSS)..... 7.0V
 Digital Inputs VSS -0.5 to VDD to 0.5V
 Digital Outputs VSS -0.5 to VDDO to +0.5V
 Storage temperature -65 to 150 ° C DC Characteristics
 Junction temperature 175° C
 Soldering temperature 260°C

Recommended Operating Conditions

VDD, VDDO (measured to VSS)..... 4.75 to 5.25V
 Operating Temperature (Ambient)..... 0 to 70°C

DC Characteristics

TTL-Compatible Inputs

PDEN, EXTFBK, SDATA, SCLK, SELn, and XTAL1/EXTREF (when EXTREF bit set to 1)

PARAMETER	SYMBOL	CONDITIONS	MIN	MAX	UNITS
Input High Voltage	V_{ih}		2.0	VDD+0.5	V
Input Low Voltage	V_{il}		VSS - 0.5	0.8	V
Input Hysteresis			.20	.60	V
Input High Current	I_{ih}	$V_{ih}=V_{DD}$	-	10	μ A
Input Low Current	I_{il}	$V_{il}=0.0$	-	200	μ A
Input Capacitance	C_{in}		-	8	pF

EXTVCO Input

PARAMETER	SYMBOL	CONDITIONS	MIN	MAX	UNITS
Input High Voltage	V_h		3.75	V_D+5	V
Input Low Voltage	V_x		$V_s - 0.5$	1.25	V

CLK+, CLK - Outputs

PARAMETER	SYMBOL	CONDITIONS	MIN	MAX	UNITS
Differential Output Voltage			0.6	-	V

OUT1, OUT2, OUT3, OUT4 Outputs

PARAMETER	SYMBOL	CONDITIONS	MIN	MAX	UNITS
Output High Voltage ($I_{OH}=4.0mA$)			2.4	-	V
Output Low Voltage ($I_{OL}=8.0mA$)			-	0.4	V

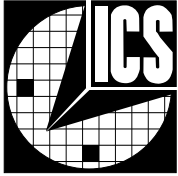

AC Characteristics

SYMBOL	PARAMETER	MIN	TYP	MAX	UNITS
Fvco	VCO Frequency	14		230	MHz
Fxtal	Crystal Frequency	5		20	MHz
Cpar	Crystal Oscillator Loading Capacitance		20		pF
FHSYNC	Horizontal Sync Rate	15		100	kHz
Txhi	XTAL1 High Time (when driven externally)	8			ns
Txlo	XTAL1 Low Time (when driven externally)	8			ns
TJIT	Phase Jitter (see Note 1)			1	ns
Tlock	PLL Acquire Time (to within 1%)			500	ms
Idd	VDD Supply Current		15		mA
Iddo	VDDO Supply Current (excluding CLK+/- termination)		20		mA
ANALOG INPUTS					
TFINE	Fine Phase Adjustment Range	0		15	ns
VFINE	Control Voltage for FINE	0		VDD/2	VDC
A	FINE Input Bias Current			20	nA
A	Capacitance of FINE Input			100	pf
A	Bandwidth of FINE Input (3dB)	0.5		1.5	kHz
DIGITAL INPUT					
A	SELn, SDATA Setup Time	10			ns
A	SELn, SDATA Hold Time	10			ns
A	SCLK Pulse Width (Thi or Tlo)	20			ns
A	SCLK Frequency			20	MHz
A	Phase-frequency detector enable time			50	ns
A	Phase-frequency detector disable time			50	ns
DIGITAL OUTPUTS					
TSKEW	Time Skew between CLK+, CLK-			500	ps
FCLK	CLK+ and CLK- Clock Rate			230	MHz
GAINS					
VCO	VCO Gain, VCO(0:2)	10		90	MHz/V
PFD	Phase Detector Gain, PFD (0:2)	.23		120	mA/2prad

Note 1: TJIT is the total uncertainty of the phase measured at the start of a video line on a 350 MHz oscilloscope under these conditions: HSYNC pin driven with crystal oscillator at 48.363 kHz; FVCO = 65.000 MHz; M =0 (divide by 1 on the output; and N = 1343 (1344 clocks per line).



Memory Definition

ICS1522 memory is loaded serially with the least significant bit clocked into the device first. After the R/Wn bit, the next three bits of the programming word (15 bits) hold the memory location to be loaded. The least significant 11 bits are the data to be loaded (see Timing Diagram).

MEMORY ADDRESS	DATA BITS	DEFAULT VALUES (HEX)	NAME	DESCRIPTION
000	0-10	04F	F(0:10)	Feedback Divider Modulus (Modulus = Value +1)
001	0-7	03	LO(0:7)	M Counter Lo Sync State
001	8-10	0	A	Don't Care
010	0-7	06	HI(0:7)	M Counter Hi Sync State
010	8-10	0	A	Don't Care
011	0-9	013	R(0:9)	Reference Divider Modulus (Modulus = Value + 1)
011	10	0	REF	POL External Reference Polarity (1 =Invert)
100	0-2	4	VCO(0:2)	VCO Gain
100	3-5	3	PFD(0:2)	Phase Detector Gain
100	6	1	PDEN	Phase Detector Enable (1 =Enable)
100	7	1	INT_FLT	Internal Loop Filter (1 = Internal)
100	8	1	INT_VCO	Internal VCO (1 = Internal)
100	9	0	CLK_SEL	Internal feedback input clock select (0 = VCO Output)
100	10	1	Reserved	Reserved - Set to One
101	0	1	FBK_SEL	Feedback Select (1 =Internal)
101	1	0	FBK_POL	External Feedback Polarity (1 =Invert)
101	2	0	ADD	Addition of 1 VCO Cycle (0 to 1 = Add)
101	3	0	SWLW	Removal of 1 VCO Cycle (0 to 1 = Swallow)
101	4-5	0	PDA(0:1)	Output Post-Scaler
101	6-7	3	PDB(0:1)	Feedback Post-Scaler
101	8	1	LD_LG	Fine Phase Adj. Lead/Lag (1=Lead)
101	9	0	F_EN	Fine Phase Adj. Enable (1=Enable)
101	10	1	Reserved	Reserved - Set to One
110	0-2	7	L(0:2)	Load Counter
110	3	0	OMUX1	OUT1 Select (0 = Load Cntr, 1 = Div By 4 0Deg)
110	4	0	OMUX2	OUT2 Select (0 = Int Fbk, 1 = Div By 4 90Deg)
110	5	0	OMUX3	OUT3 Select (0 = Sync Lo, 1 = Div By 4 180Deg)
110	6	1	OMUX4	OUT4 Select (0 = Sync Hi, 1 = Div By 4 270Deg)
110	7	0	DACRST	Output Reset (CLK+ = 1, CLK- = 0)
110	8	0	AUXEN	Output Test Mode (1 = Test, See Board Test Support)
110	9	0	AUXCLK	Output Clock When in Test Mode
110	10	0	EXTREF	XTAL/EXTREF Input Buffer (1=EXTREF)

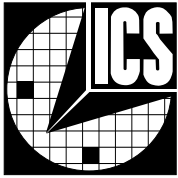

Pixel-by-Pixel Adjustment of Genlocking Phase (ICS1522 Application)

To understand the operation of the pixel-by-pixel phase adjustment feature, imagine that the modulus of the on-chip divider is equivalent to the graphics system overall divide. Also, imagine that the overflow of the internal divider occurs at the same time as the overflow of the graphics system line counter. Initial synchronization is accomplished by switching from the external feedback source (graphics system HSYNC) to the internal feedback. Let us assume that we are now using the internal divider.

Now, imagine that the programmed value of the divider (really a prescaler) is increased by one for a single pass-through that prescaler (think of this as “swallowing” a feedback pulse). We will lose exactly one CLK period of phase in the feedback path. The VCO will speed up momentarily to compensate for that, and re-lock the loop.

In doing so, the graphics system will receive exactly one extra CLK cycle, advancing the phase of the graphics system HSYNC by one CLK period relative to the reference HSYNC. In a similar fashion, we can decrease the programmed value of the prescaler (“adding” a pulse) to retard the phase of the graphics system. Additionally, sub-pixel phase adjustment is provided through varying the voltage at the FINE input pin.

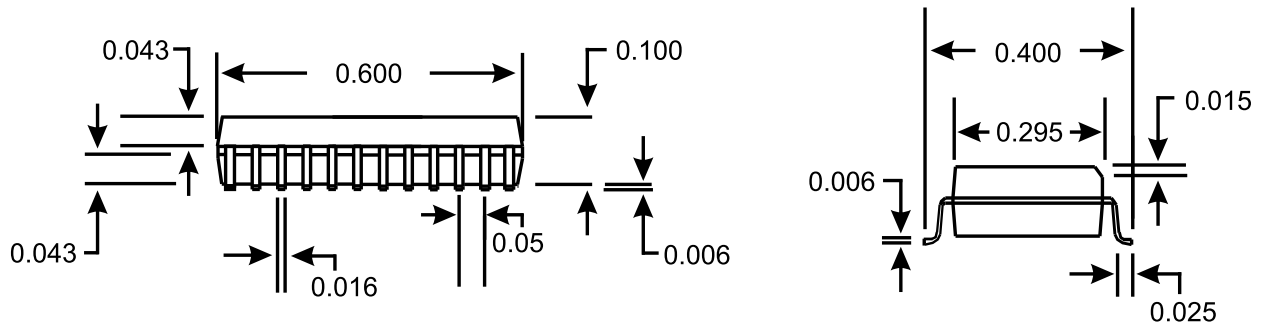

24-Pin SOIC Package

Ordering Information

ICS1522M

Example:

ICS XXXX M

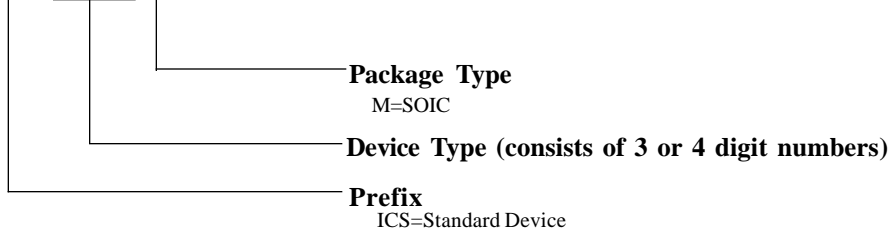

ICS reserves the right to make changes in the device data identified in this publication without further notice. ICS advises its customers to obtain the latest version of all device data to verify that any information being relied upon by the customer is current and accurate.