



---

## QuickSaver® Charge Control IC for Nickel-Cadmium and Nickel-Metal Hydride Batteries

---

### General Description

The **ICS1708** is a low cost 8 pin CMOS control IC for the intelligent charging of either nickel-cadmium (NiCd) or nickel-metal hydride (NiMH) batteries. The **ICS1708** uses a pulsed-current charging technique together with multiple voltage slope termination methods. The **ICS1708** employs a four stage charge sequence that provides a complete recharge without overcharging. The controller has three (3) user selectable charge rates, user accessible clock, and two (2) charge status output pins. On power-up, the **ICS1708** monitors for the presence of a battery and begins charging. The **ICS1708** is for applications where battery temperature protection is not required of the charge controller.

### Applications

Embedded and charger stands for: Portable consumer products, Power tools, Audio/video products, Communications products, RC toys, and Wireless products

### Features

- Charge termination methods include: Voltage slope ( $+\Delta V/dt$  and  $\pm$  peak detect), and Fast charge time out to maintenance mode
- Four stage charge sequence: *SoftStart* conditioning, Fast charge, Topping charge, and Maintenance charge
- Three (3) user selectable charge rates: 15 minutes (4C), 60 minutes (1C), 150 minutes (C/2.5)
- Continuous polling mode for battery detection
- Adjustable open circuit (no battery) voltage reference

### Benefits -compared to other methods

- Peak battery performance and extended cycle life
- Improved battery efficiency and reliability
- Lower internal resistance build-up
- Lower capacity fade

### Block Diagram

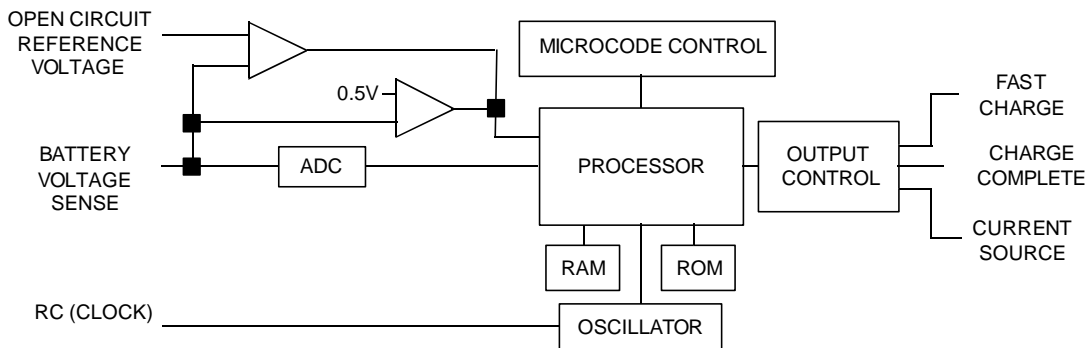



## Pin Configuration

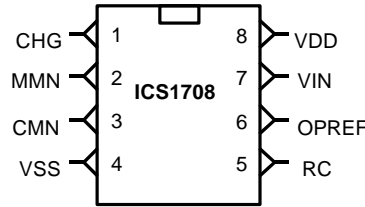

### 8-Pin DIP or SOIC

## Pin Definitions

Pin	Name	Type	Definition
1	CHG	OUT	Active high (PFET), active low (NFET) 25mA max. TTL compatible signal used to turn on and off an external current source to provide pulsed current to charge the battery.
2	CMN	OUT	Charge mode indicator. NFET drain rated at 40mA max. turns on an external indicator to show the controller is applying either a <i>SoftStart</i> charge or fast charge.
3	MMN	OUT	Maintenance mode indicator. NFET drain rated at 40mA max. turns on an external indicator showing the battery is ready to use as the topping charge or maintenance charge is applied.
4	VSS		Ground.
5	RC	IN	An external resistor and capacitor sets the frequency of the internal clock.
6	OPREF	IN	Open circuit (no battery) voltage reference. A pull down or external resistor divider from 5V sets a voltage reference on this pin used to detect the presence of a battery.
7	VIN	IN	Battery voltage normalized to one cell with an external resistor divider.
8	VDD		Device supply =+5.0 VDC +/- 5% regulated. The ICS1708 requires 11mA max. average that includes brief 50mA peak currents. When used, LEDs, pull-up resistors, and drivers require additional current from the +5VDC supply. An electrolytic and ceramic capacitor between (or very close to) both VDD and VSS is recommended for bypassing.

Note: Pin 6 has an internal pull-up.  
Input and output pins have internal ESD protection diodes to VDD and VSS for 2KV protection per MIL STD 883 method 3015.7.

## Controller Operation

### Charging Stages

The charging sequence consists of four stages. The application of current is shown graphically in Figure 1. The *SoftStart* stage gradually increases current levels up to the user selected fast charge rate during the first two minutes. The *SoftStart* stage is followed by the fast charge stage, which continues until termination. After fast charge termination, a reduced duty cycle topping charge is applied, followed by a further reduced cycle maintenance charge. After fast charge termination, the battery is charged and ready to use.

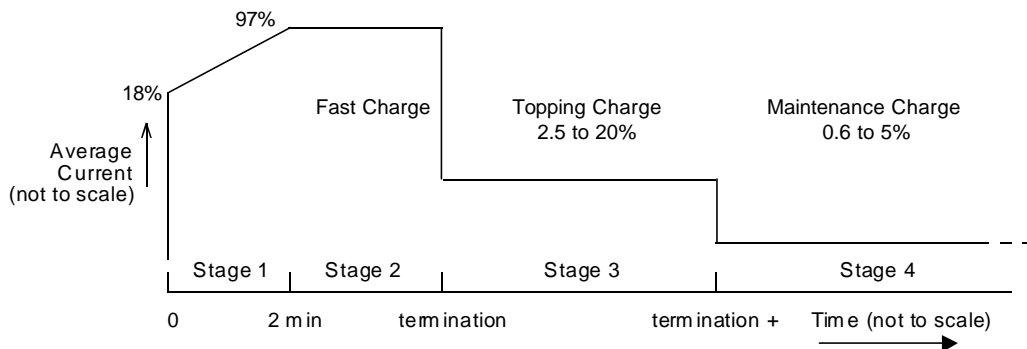

Figure 1: Graphical representation of average current levels during the four charging stages



### SoftStart Conditioning Charge

New, over-discharged, and batteries out of long term storage may exhibit an initial high impedance conditions in response to charging, as shown in Figure 2. Unless dealt with, this high impedance condition can cause a voltage peak and  $-\Delta V$  condition at the beginning of the charge cycle that can appear to be the response of an already full battery. To manage this condition, the **ICS1708** applies a *SoftStart* conditioning charge.

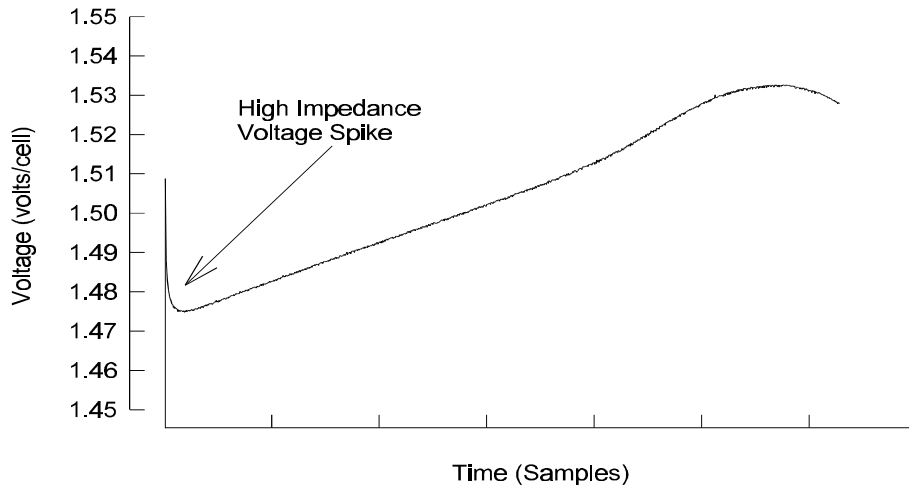

Figure 2: High impedance voltage spike at the beginning of charge

The *SoftStart* charge eases batteries into the fast charge stage by gradually increasing the duty cycle of the charge. The gradual increase alleviates the voltage peak and the  $-\Delta V$  condition. The duty cycle of the applied current is increased to the fast charge rate, as shown in Figure 3, by extending the current pulse on every cycle until the pulse is about 1.1 seconds in duration. The initial current pulse is approximately 200ms. The CMN indicator is a continuous active low during the *SoftStart* conditioning stage.

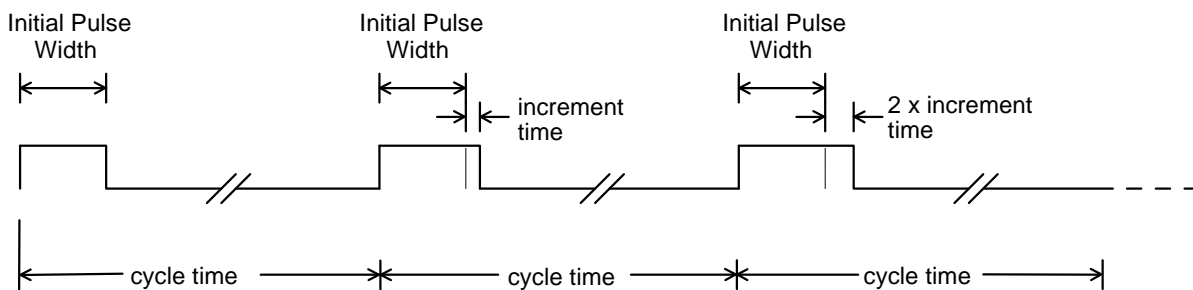
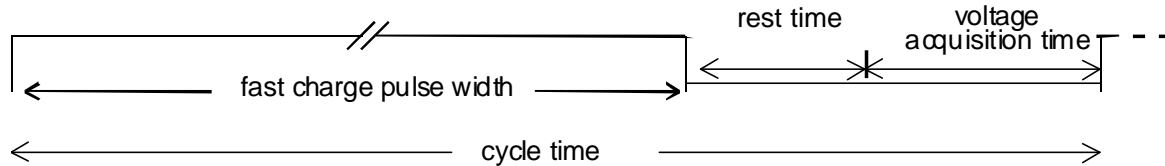

Figure 3: Cycle-to-cycle increase of the *SoftStart* current pulse widths



## Fast Charge

In the second stage, the **ICS1708** applies the charging current in a repetitive sequence consisting of positive current charging pulses followed by a rest time and voltage acquisition time. The cycle, shown with charge, rest, and data acquisition periods in Figure 4, repeats every 1.1 seconds until the battery is fully charged.



**Figure 4: Charge cycle showing fast charge current pulses**

The amplitude of the current pulse is determined by system parameters such as the current capability of the charging system, the desired recharge time, battery capacity and the ability of the battery to accept the charge current in the charging environment. The **ICS1708** can be set for three (3) user-selectable fast charge rates: 15 minutes (4C), 60 minutes (1C), or 150 minutes (C/2.5). The CMN indicator is a continuous active low during this stage. The charge rate is determined by the voltage level on the CMN indicator when the **ICS1708** is first powered-up.

A voltage acquisition window immediately follows a brief rest time after the charge pulse. No charge is applied during the rest time or during the acquisition window to allow the battery chemistry to settle. Since no current is flowing, the measured cell voltage is not obscured by any internal or external IR drops or noise. The **ICS1708** takes samples of battery voltage during the acquisition window. The voltage samples are averaged for comparisons to previous and subsequent averages. This method provides a most accurate representation of the true state of charge of the battery.

## Topping Charge

The third stage is a topping charge that applies current at a rate low enough to prevent cell heating but high enough to equalize cells in a multiple cell packs. The topping stage is not required before putting the battery into immediate service after fast charge completes.

The topping charge is applied for a minimum of two (2) hours. The current consists of the same pulse technique used during the fast charge stage; however, the delay time is extended as shown in Figure 5. Extending the delay time between charge pulses allows the same charging current used as in the fast charge stage so that no changes to the current source are necessary. For example, the same charge pulse that occurs every second at a 1C (1 hour) fast charge rate will occur every eleven (11) seconds for a topping charge rate of C/11. The MMN indicator is a continuous active low during the topping and maintenance charge stages.

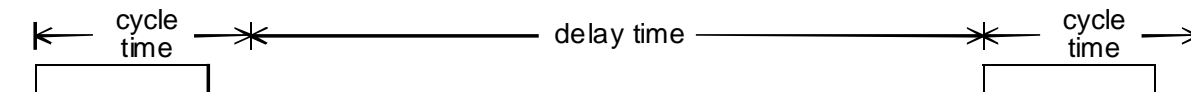

**Figure 5: Representative timing diagram for topping and maintenance charge**

## Maintenance Charge

The maintenance charge is intended to offset the natural self-discharge of NiCd or NiMH batteries by keeping their cells primed at peak charge. After the topping charge ends, the **ICS1708** begins this charge stage by once again extending the delay time between charge pulses. The maintenance charge will last for as long as the divided down battery voltage is greater than 0.5V at VIN pin 7. The MMN indicator is a continuous active low during this stage.



### Charge Termination Methods

Charge termination methods include voltage slope and fast charge time out.

#### *Voltage Slope Termination*

The most distinctive point on the voltage curve of a battery in response to charging by a constant amplitude current is the voltage peak that occurs as the battery approaches full charge. By mathematically calculating the first derivative of the voltage, a second curve can be generated showing the change in voltage with respect to time as shown in Figure 6. The slope will reach a maximum just before peak voltage. Using milestone voltage slope data as charging progresses, the **ICS1708** determines when the point of full charge will occur and accurately terminates the applied current when the battery reaches that point. The actual termination point is based on the actual charging characteristics of the particular battery. Typically, fast charge ends around peak voltage.

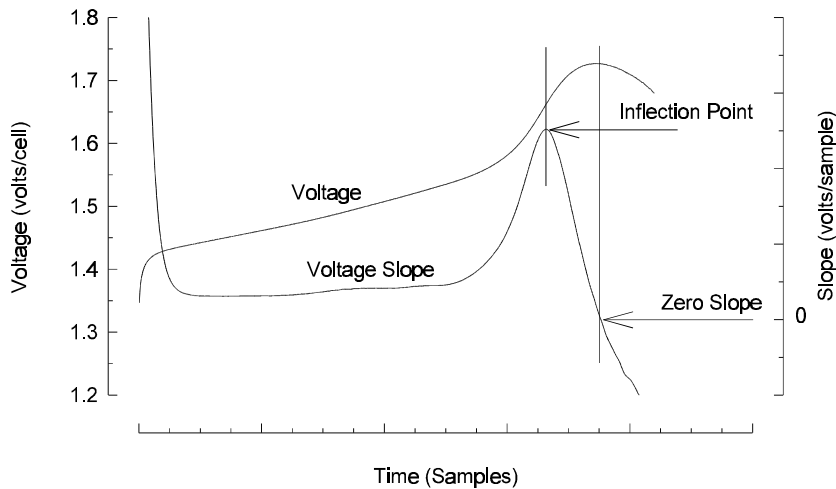

**Figure 6: Voltage and slope curves showing inflection and zero slope points**

New, over-discharged, old, and already full batteries often produce a voltage profile that varies from that shown in Figure 6. The **ICS1708** fast charge termination in these cases is based on a slight decrease in the voltage. Some new batteries may need several charge/use cycles before their response fully stabilizes to that shown in Figure 6.

#### *Charge Timer Termination*

The controller uses a timer to limit fast charge duration. These times are internally set according to the charge rate selected and can be adjusted slightly by changing the clock frequency. Fast charge timer termination is a safety backup feature to limit the duration of the fast charge stage. The fast charge timer is always active and cannot be disabled. See Table 3 *Charge Rate List*.



## Battery Detection

If upon initial power-up, voltage at VIN pin 7 is less than 0.5V, the **ICS1708** assumes no battery is present, and the polling detect mode is initiated.

The **ICS1708** enters the polling detect mode using CHG pin 1 and applies a 100ms charge pulse. During the first 4ms pulse, the **ICS1708** monitors the VIN pin 7 to determine if voltage is above the voltage set on OPREF pin 6. If the battery is present, the voltage at VIN pin 7 will be held below the voltage set on OPREF pin 6 while the current pulse is applied. If a battery is not present, the voltage at VIN pin 7 will rise above the voltage set on OPREF pin 6.

If the voltage at VIN pin 7 exceeds the voltage set on OPREF pin 6, the **ICS1708** will wait for about one-half second after the 100ms charge pulse ends before producing another 100ms charge pulse. The process repeats until the battery connects. When the battery connects, the 100ms polling pulse is extended for another 100ms and the pulse becomes the first *SoftStart* conditioning pulse of 200ms. An over-discharged or low voltage battery does not interfere with a prompt start of *SoftStart*. The **ICS1708** will automatically re-enter the polling detect mode if the battery is removed.

## Battery Removal

During the first 4ms of the application of a charge pulse, the voltage at the VIN pin 7 is compared to the voltage set at the OPREF pin 6. If the voltage at VIN pin 7 is greater than the voltage set at OPREF pin 6 during the application of the current pulse, then the battery is assumed to have been removed and the **ICS1708** enters the polling detect mode. If the voltage at VIN pin 7 is held below the voltage set at OPREF pin 6, charging continues.

When in the topping charge or maintenance charge stages, a charge pulse may not occur for several seconds or longer. So, during the period between charge pulses, the voltage at VIN pin 7 is compared to the internal 0.5V reference. If the voltage at VIN pin 7 is less than 0.5V, the **ICS1708** assumes the battery has been removed, and the polling detect mode is initiated.

## Pin Descriptions

In addition to a regulated +5V supply, the **ICS1708** requires a few other external components to control the clock rate and provide an indicator display. The **ICS1708** is interfaced to turn on and off an external current source

### Output Logic Signals: CHG pin 1

The CHG pin 1 is active high/low, TTL compatible output. In addition to being TTL compatible, the CMOS output is capable of sourcing and sinking up to 25mA which adds flexibility when interfacing to other circuitry. A logic high on CHG pin 1 indicates that the constant current source is on. A logic low turns off the constant current source. Normal care must be taken to control wiring resistance and inductance.

### Charge Status Indicators: CMN pin 3, MMN pin 2

The controller has two outputs for driving external indicators. These pins are active low. These two indicator outputs are open drains when off. They can sink up to 40mA which allows for sinking LED current with use of external current limiting resistors. These two indicator outputs denote charge status: fast charge or topping/maintenance charging as shown in Table 1.

**Table 1: Indicator Description List**

MMN	CMN	Description
On		Charge complete (battery ready to use) as maintenance or topping charge is applied
	On	Fast charge (including <i>SoftStart</i> conditioning)
	Flash	See applications information
On		At power-up or with battery insertion

The charge mode (CMN) indicator is low continuously during the *SoftStart* and fast charge stages. When the controller enters the topping charge stage, the output turns off and the indicator turns off. When the maintenance mode (MMN) indicator is on and as the battery is ready to use, the **ICS1708** applies the topping and maintenance charge.

The **ICS1708** does not control the current flowing into the battery in any way other than turning it on and off. The required current for the selected charge rate is provided by the system's input power source. The external charging circuitry provides current at the selected charge rate. For example, to charge a 1.2 ampere hour battery in 60 minutes (1C), 1.2 amperes is required.



### Clock Input: RC Pin

The RC pin is used to set the frequency of the internal clock. Alternatively, an external 1 MHz clock may be used. Normally an external resistor is connected between this pin and VDD. An external capacitor is connected between this pin and ground (VSS). The frequency of the internal clock is typically 1 MHz with a 15kΩ resistor and a 100pF capacitor. All time durations noted in this document are based on a 1 MHz clock. Operating the clock at a lower frequency will proportionally change all time durations. Operating the clock at a frequency significantly lower than 1 MHz, without adjusting the charge current accordingly, will lessen the effectiveness of the fast charge timer and lower the accuracy of the controller. Operating the clock at a frequency greater than 1 MHz will also change all time durations and, without adjusting the charge current accordingly, may cause termination to occur due to the fast charge timer expiring rather than by the battery reaching full charge.

The clock may be driven by a 1 MHz external 0 to 5V pulse provided the duty cycle is between 10% and 60%. The clock input impedance is typically 1kΩ.

### Voltage Input: VIN Pin

The battery voltage is normalized by an external resistor divider network to one cell. The electrochemical potential of one cell is about 1.2V. For example, if the battery consists of six cells in series, the voltage at the VIN pin should be set to equal to the total battery voltage divided by six. This is accomplished with two resistors, as shown in Figure 7.

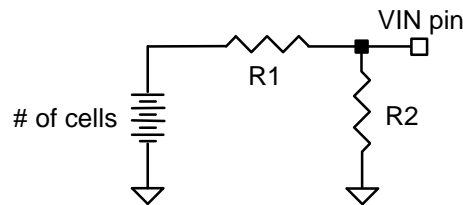

Figure 7: Resistor divider network at the VIN pin

To determine resistor values, count the number of cells to be charged in series. Then choose either R1 or R2 and solve for the other resistor using:

$$R1 = R2 * (\# \text{ of cells} - 1) \text{ or } R2 = \frac{R1}{(\# \text{ of cells} - 1)}$$

R2 value should be kept below 27K so that if a 0.047μF capacitor is used in parallel with it, more than five RC time constants occur before data acquisition. Consult the factory for applications that require use of higher resistance voltage dividers.

### Circuit Voltage Reference: OPREF pin 6

The OPREF pin has an internal 85kΩ pull-up resistor to VDD. OPREF requires an external pull-down resistor to establish the open circuit (no battery) voltage reference. The purpose of this voltage reference is to detect the removal of the battery from the charging system. The voltage at this pin is compared to the voltage at the VIN pin for the first 4mssec after the current source is turned on by CHG pin 1. If the voltage at VIN is greater than the voltage set on OPREF, the ICS1708 assumes the battery has been removed and the ICS1708 enters the polling detect mode.

For proper operation, the voltage on OPREF pin 6 is set below the (divided down) no battery voltage at VIN pin 7 produced by the current source (when on) and above the maximum normalized voltage at VIN pin 7 with a battery present. The OPREF pin voltage must not exceed 2.3V or it will prevent the start of fast charge. If the voltage on OPREF exceeds 4V, the controller will shutdown and power to the ICS1708 must be removed and restored to restart the ICS1708.



As an example, suppose that a current source has an open circuit voltage of 12V as shown in Figure 8.

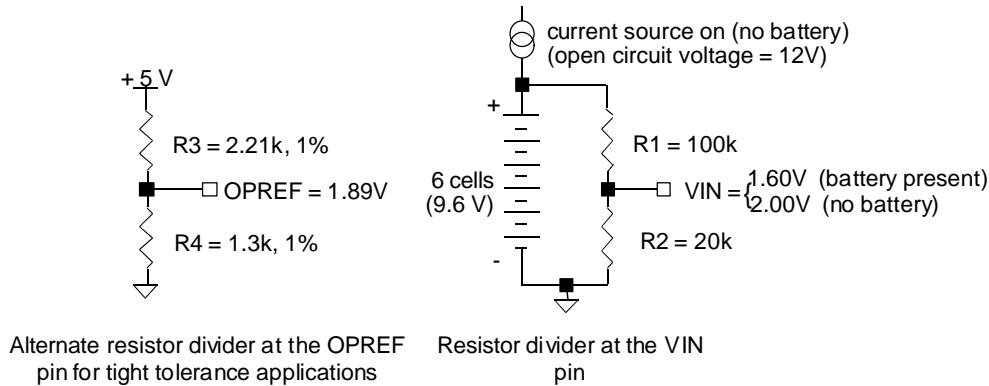

**Figure 8: Open Circuit Reference Example**

The maximum battery voltage of a nearly full six-cell pack with current applied is determined to be 9.6V. The voltage at OPREF should then be set at a point between 1.6V (9.6V/6 cells=1.6V) and 2V (12V/6=2V). This can be accomplished with a pull-down resistor. Refer to the VIN and OPREF resistor tables in the *Applications Information* section. From the VIN table, the divider resistors are 100kΩ and 20kΩ for R1 and R2. From the OPREF table, the pull-down resistor is 47KΩ for R3. If R3 is 47KΩ, the voltage at OPREF is typically 1.78V since the internal pull-up at the OPREF pin is 85kΩ. Figure 8 show an alternate approach for setting the voltage on OPREF for tight tolerance applications.

**Power: VDD pin 8**

The power supply for the device must be connected to the VDD pin. The voltage is +5 VDC nominal, series regulated for proper noise rejection. A 100mA or higher current rating supplies the controllers maximum of 11mA average demand that includes brief 50mA peaks. Peripheral circuits current requirements are added to these requirements. See Pin Descriptions for additional information.

**Grounding: VSS pin 6**

This pin is connected directly to a solid (low impedance) ground that connects at or close to battery minus. See the section Pin Descriptions and Applications Information (PC Board Design Considerations) for additional information.

## Charge Rate Selection

The voltage set on CMN pin 3 prior to the start of fast charge sets one of three fast charge rates shown in Table 2.

**Table 2: Charge Rate List**

Selected Charge Rate	Topping Charge Pulse Rate	Maintenance Charge Pulse Rate	Fast Charge Timer Duration (after power-up or battery insertion)
4C (15 min)	one every 41 sec	one every 161 sec	21 min
1C (60 min)	one every 11 sec	one every 41 sec	75 min
C/2.5 (150 min)	one every 5 sec	one every 17 sec	212 min

See the section on *Controller Operation* for additional information on the topping charge and maintenance charge. See the section on *Charge Termination Methods* for additional information on the charge timer.





The 1C (60 minute rate) is selected by using a 10K pull-up resistor from CMN pin 3 to VDD pin 8 (+5V REG.) as shown in Figure 9A "Charging System Diagram". The 10K pull-up resistor is required even if an LED with a current limited pull-up to VDD pin 8 (+5V reg.) is used. The C/2.5 (150 minute) rate is selected using the 330/1.3K resistor divider with a general purpose LED as shown in Figure 9B. Based on the LED selection, this configuration should provide the 2.5V +/- 0.5V on CMN pin 3 prior to the start of fast charge to activate the C/2.5 (150 minute) rate as shown in Figure 9B. Setting the 4C (15 minute) rate involves setting the voltage at CMN pin 3 below 0.5V prior to the start of fast charge as shown in Figure 9C. A 10K pull-up resistor, a 2K pull-down resistor and a 1N4148 or equivalent diode is used to keep CMN below 0.5V at power up or upon battery removal. When CMN goes low to ground of its own accord, the base of a 2N3903 or equivalent NPN transistor is pulled low via the 1N4148 diode allowing the LED indication for fast charge.

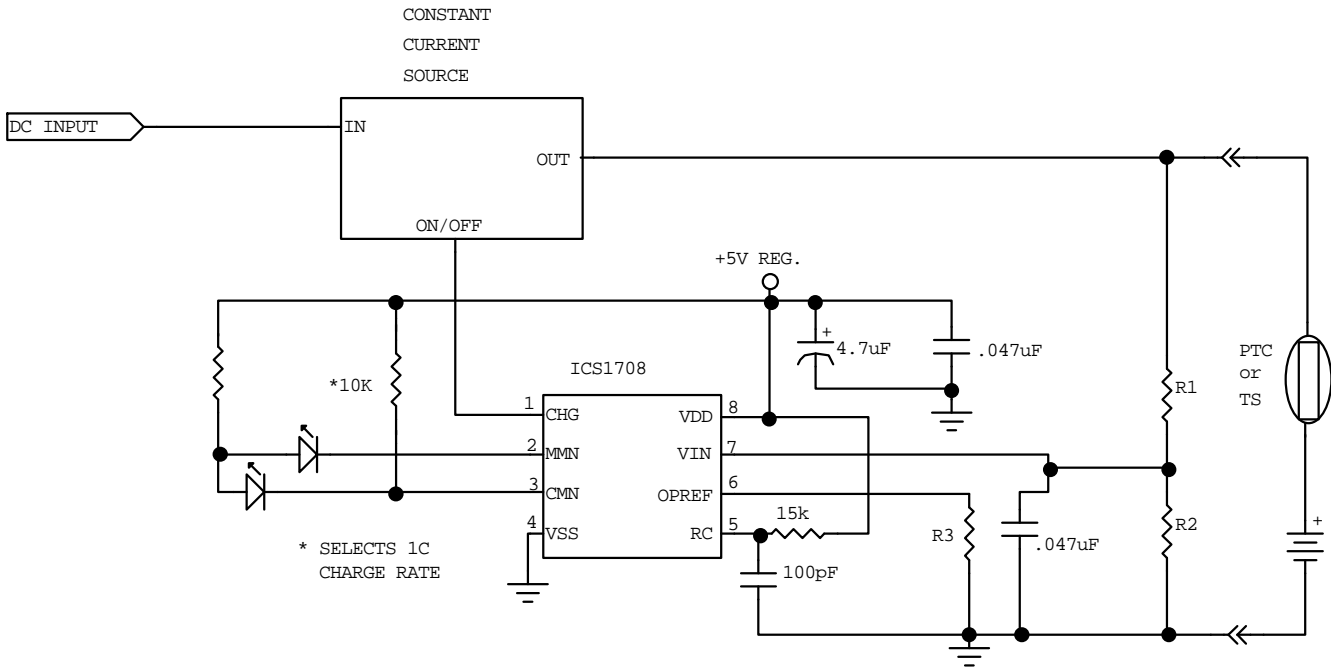
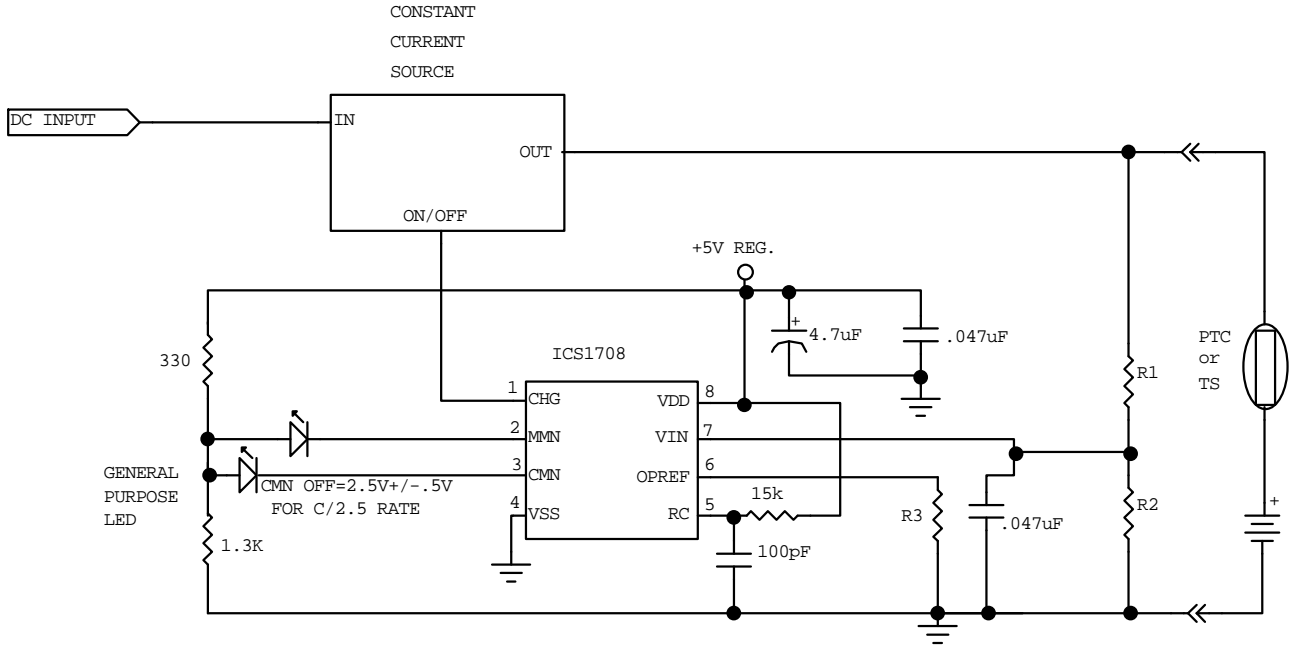
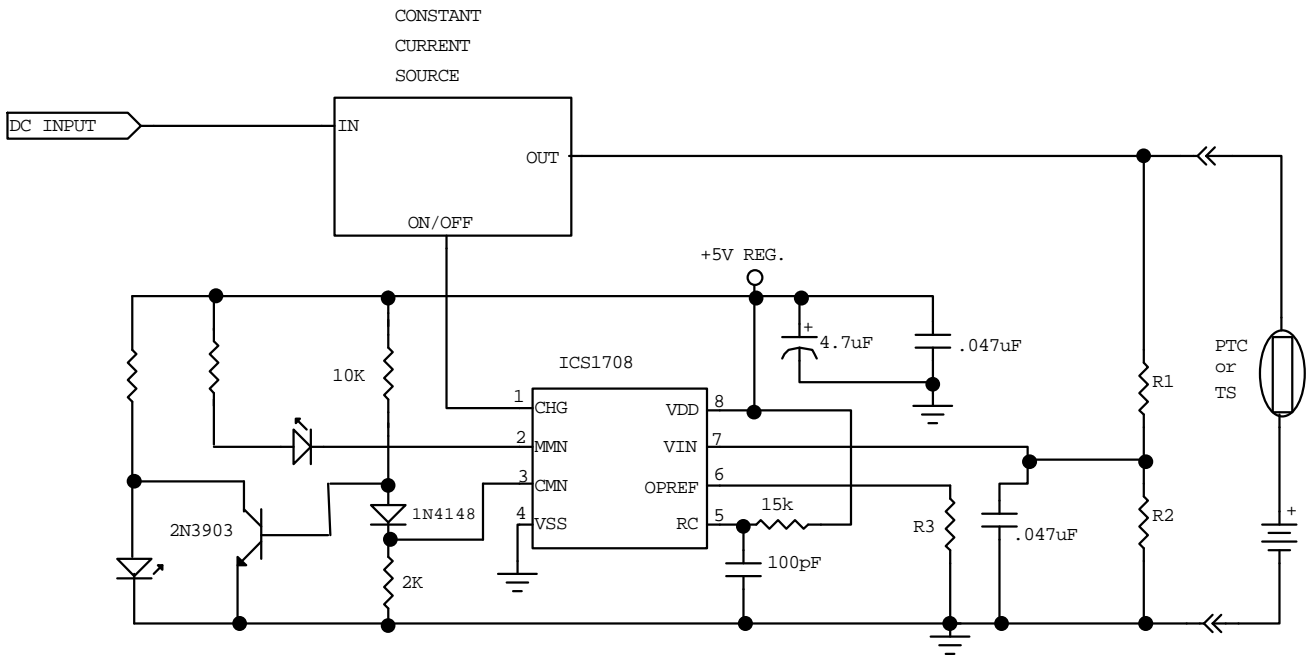

FIGURE 9A: Charging System Diagram for 1C (60 minute) Charge Rate

# ICS1708



**FIGURE 9B: Charging System Diagram for C/2.5 (150 Minute) Charge Rate**



**FIGURE 9C: Charging System Diagram for 4C (15 minute) Charge Rate**



**Data Tables**

**Table 3: Absolute Maximum Ratings**

Supply Voltage	6.5	V
Input/Output Levels	-0.5 to VDD + 0.5	V
Ambient Operating Temperature	70	°C
Storage Temperature	-55 to 150	°C

Stresses above those listed under Absolute Maximum Ratings may cause permanent damage to the device. This is a stress rating only. Functional operation of the device at the Absolute Maximum Ratings or other conditions not consistent with the characteristics shown in this document is not recommended. Exposure to absolute maximum rating conditions for extended periods affects product reliability.

**Table 4: DC Characteristics**

T<sub>amb</sub>=25°C.

Parameter	Symbol	Conditions	MIN	TYP	MAX	UNITS
Supply Voltage	V <sub>DD</sub>		4.5	5.0	5.5	V
Supply Current	I <sub>DD</sub>			7.3		mA
Internal pull-up OPREF	I <sub>IL</sub>			75		kΩ
High Level Source Current CHG	I <sub>OH</sub>	V= V <sub>DD</sub> - 0.4V		25		mA (max)
Low Level Sink Current CHG	I <sub>OL</sub>	V=0.4V		25		mA (max)
Low Level Sink Current, indicator CMN, MMN	I <sub>OL</sub>	V=0.4V		40		mA (max)
Analog/Digital Converter Range			0-2.2	0-2.3	0-2.3	V
Minimum Battery Threshold				0.5		V

**Table 5: Timing Characteristics**

R≈15kΩ, C≈100pF

PARAMETER	SYMBOL	REFERENCE	TYP	UNITS
Clock Frequency			1.0	MHz
Charge Pulse Width in Fast Charge Stage	t <sub>FCHG</sub>	see Figure A	1048	ms
Rest Time	t <sub>R</sub>	see Figure A	13.0	ms
Data Acquisition Time	t <sub>DA</sub>	see Figure A	16.4	ms
Cycle Time	t <sub>CYCLE</sub>	see Figure A	1077	ms
Polling Detect Pulse Width			100	ms
Polling Detect Pulse Period			624	ms
SoftStart Initial Pulse Width			200	ms
SoftStart Incremental Pulse Width			7.0	ms
Rate Select Read of CMN pin 3 at power-up or with battery removed after fast charge starts			1160	ms



## Timing Diagram

Figure A:

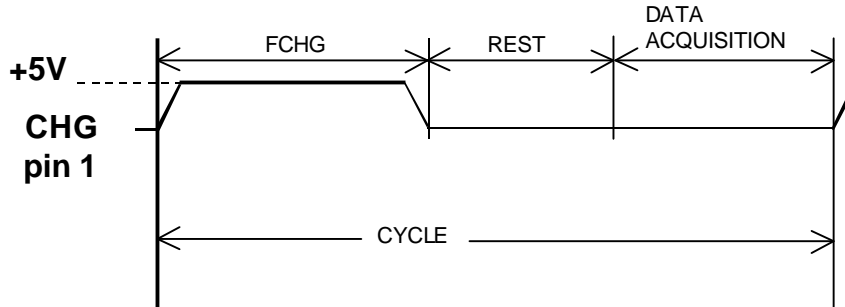

## Applications Information

To ensure proper operation of the **ICS1708**, external components must be properly selected. The external current source used must meet several important criteria to ensure adequate performance of the charging system. The charging current source amplitude should be fairly constant

### VIN and OPREF Divider Resistors

Figure 9 shows a typical application using the **ICS1708**. R1 through R3 must be selected properly to ensure that battery detection and voltage termination methods operate properly. R1 and R2 are selected to scale the battery voltage down to the voltage of one cell. The following table shows some typical values.

Cells	R1	R2
1	20k	*
2	20k	20k*
3	39k	20k
4	62k	20k
5	82k	20k
6	100k	20k
7	120k	20k
8	150k	20k
9	160k	20k
10	180k	20k
11	200k	20k
12	220k	20k
13 & Above	R1=R2 x (# cells - 1)	

\* Use 5.1V Zener as required depending on input voltage

If the current source is a switch mode type, normal ripple current does not effect the **ICS1708**. However, the effects of line frequency ripple may interfere with proper performance. R3, per Figure 9, can be used to set the open circuit (no battery) reference voltage on the OPREF pin. The function of this pin is discussed in the *Open Circuit Reference* section.

V <sub>OPREF</sub>	R3
1.68 V	43k
1.78 V	47k
1.88 V	51k
1.99 V	56k
2.11 V	62k

See Figure 8 for an alternate resistor divider approach at the OPREF pin for tight tolerance applications.



With the battery removed, the current source must be capable of raising the voltage at the VIN pin above the voltage at the OPREF pin to ensure proper polling. With the batteries installed, the current source overshoot characteristics when turned on and off must not cause the voltage at the VIN pin to approach the voltage at the OPREF pin. If the voltage at OPREF exceeds the voltage at VIN when a charge pulse is applied, the polling feature will be activated.

### *PC Board Design Considerations*

It is very important that care be taken to minimize noise coupling and ground bounce. Careful placement of wires and connectors helps minimize resistance and inductance.

When designing the printed circuit board, make sure ground and power traces are wide and bypass capacitors are used right at IC power and ground pins. Use separate heavy grounds for both signal and power circuits, connecting their grounds together close to where the negative lead of the battery connects. For power circuits, keep the physical separation between power and return (ground) to a minimum to minimize field effects. This precaution is most applicable to the constant current source, particularly if it is a switch mode type. Keep the **ICS1708** and the constant current source control circuits outside the power and return loop described above. These precautions will prevent high fields and coupled noise from disturbing normal operation. Avoid jumping across power and return with signal lines.

### *Using the Voltage Slope Termination Method*

In general the voltage slope termination method works best for products where the battery is fast charged with the product off, or the battery is removed from the product for fast charge in a charger stand.

The voltage slope termination method used by the **ICS1708** requires a nearly constant amplitude current flow into the battery during fast charge. Charging the battery in products that draw a known and fairly constant current while the battery is charging should have this current draw added to the fast charge current. Using the **ICS1708** for charging the batteries in products that randomly or periodically requires moderate current from the battery during fast charge needs evaluation. Products that randomly or periodically require high current from the battery during fast charge may cause a voltage inflection that results in termination before full charge. A voltage inflection can occur due to the charge current decreasing or fluctuating as the load changes rather than by the battery reaching full charge. The voltage slope method will terminate charge based on voltage inflections that are characteristic of a fully charged battery. The ICS1702 and ICS1712 charge controllers have temperature termination methods for products that randomly or periodically draw significant current from the battery during fast charge.

Charging sources that produce decreasing current as fast charge progresses may also cause a voltage inflection that may result in termination before full charge. For example, if the charge current is supplied through a resistor or if the charging source is a constant current type that has insufficient input voltage, the current will decrease and may cause a termination before full charge. Other current source abnormalities that may cause a voltage inflection that is characteristic of a fully charged battery are inadequate line frequency ripple attenuation capability or charge current decreasing due to thermal drift or thermal limiting. Charging sources that have any of the above characteristics need evaluation to access their suitability for the application if the use of voltage slope termination is desired.

The controller *SoftStart* stage, built-in noise filtering, and fast charge timer operate optimally when the constant amplitude current source charges the battery at the rate selected. If the actual charge current is significantly less than the rate selected, the conditioning effect of the *SoftStart* stage and the controller noise immunity are lessened. Also, the fast charge timer may cause termination based on time duration rather than by the battery reaching full charge due to inadequate charge current.

### *Charging System Status by Indicator*

The *Indicator Description List* in Table 2 contains some displays that are caused by charging system abnormalities. When the CMN indicator flashes, there may be voltage present at the charger terminals with the current source off with no battery connected. Check the current source and ensure that it produces no more than 350mV at VIN pin 7 when the current source is turned off with no battery connected. If VIN pin 7 divider resistors are not properly selected, an open circuit voltage that should produce less than 350mV with the charger off and no battery will not divide down the open circuit voltage properly and produce the CMN flash indication. Check the VIN divider and ensure that it properly scales the battery voltage to the 1 cell level at VIN pin 7. If the CMN flash indication occurs with the battery installed, there may be an open connection in the charger or the battery. Check wires, connections, battery terminals, and the battery itself for an open circuit condition.

If the MMN indicator is active at the initiation of fast charge, check the external pull-down resistor or alternate divider off 5V that sets the voltage on OPREF pin 6. If the voltage set on OPREF is greater than 2.3V but less than 4V, the start of fast charge will be inhibited until the voltage on OPREF is lowered.



# ICS1708

## Package Information

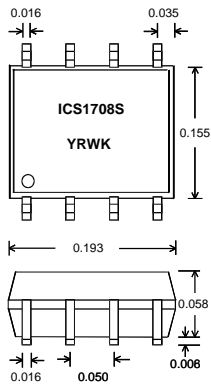

All package dimensions are in inches.  
**8-Pin SOIC Package (150 mil)**

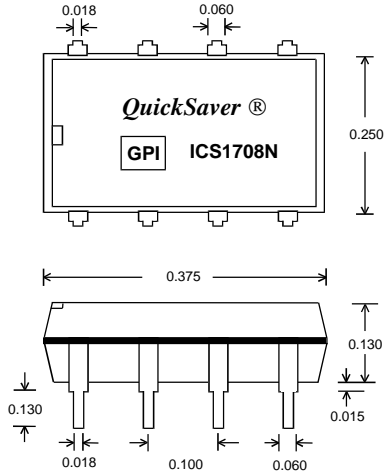
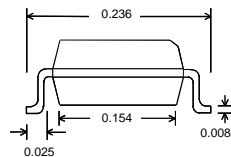

All package dimensions are in inches.  
**8-Pin DIP package (300 mil)**

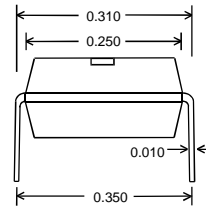

## Ordering Information

ICS1708S, ICS1708ST, ICS1708N

### Example:

ICS 1708 ST

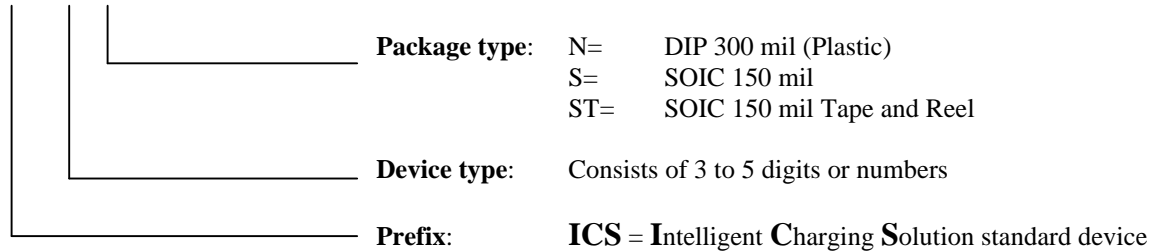



---

## IMPORTANT NOTICE

Galaxy Power Incorporated makes no claim about the capability of any particular battery (NiCd or NiMH) to accept a fast charge. GPI strongly recommends that the battery manufacturer be consulted before fast charging. GPI shall be held harmless for any misapplication of this device such as: exceeding the rated specifications of the battery manufacturer; charging batteries other than nickel-cadmium or nickel-metal hydride type; personal or product damage caused by the charging device, circuit, or system itself; unsafe use, application, and/or manufacture of a charging system using this device.

GPI reserves the right to make changes in the device data identified in this publication without further notice. GPI advises its customers to obtain the latest version of all device data to verify that any information being relied upon by the customer is current and accurate.

GPI does not assume any liability arising out of or associated with the application or use of any product or integrated circuit or component described herein. GPI does not convey any license under its patent rights or the patent rights of others described herein. In the absence of a written or prior stated agreement to the contrary, the terms and conditions stated on the back of the GPI order acknowledgment obtain.

GPI makes no warranty of any kind with regard to this material, including, but not limited to, the implied warranties of merchantability and fitness for a particular purpose.

GPI products are not designed, intended, or authorized for use as components in systems intended for surgical implant into the body, or other applications intended to support or sustain life, or for any nuclear facility application, or for any other application in which the failure of the GPI product(s) could create a situation where personal injury or death may occur. GPI will not knowingly sell its products for use in such applications, and the buyer shall indemnify and hold harmless GPI and its officers, employees, subsidiaries, affiliates, representatives and distributors against all claims, costs, damages, expenses, tort and attorney fees arising out of directly or indirectly, any claim of personal injury or death associated with such unintended or unauthorized use, even if such claim alleges that GPI was negligent regarding the design or manufacture of the part.

COPYRIGHT © 2000 Galaxy Power Incorporated

**ICS1708**



---

**Galaxy Power, Inc.**

PO Box 890

2500 Eisenhower Avenue

Valley Forge, PA 19482-0890

Phone: 610-676-0188

FAX: 610-676-0189

WWW: [www.galaxypower.com](http://www.galaxypower.com)

E-mail: [halla@galaxypower.com](mailto:halla@galaxypower.com)

---