



Description

The ICS527-01 Clock Slicer™ is the most flexible way to generate an output clock from an input clock with zero skew. The user can easily configure the device to produce nearly any output clock that is multiplied or divided from the input clock. The part supports non-integer multiplications and divisions. A SYNC pulse indicates the rising clock edges that are aligned with zero skew. Using Phase-Locked Loop (PLL) techniques, the device accepts an input clock up to 200 MHz and produces an output clock up to 160 MHz.

The ICS527-01 aligns rising edges on ICLK and FBIN at a ratio determined by the reference and feedback dividers.

For configurable clocks that do not require zero delay, use the ICS525.

Features

- Packaged as 28 pin SSOP (150 mil body) 
- Synchronizes fractional clocks rising edges
- User determines the output frequency - no software needed
- Slices frequency or period
- SYNC pulse output indicates aligned edges
- Input clock frequency of 600 kHz - 200 MHz
- Output clock frequencies up to 160 MHz
- Very low jitter
- Duty cycle of 45/55 up to 160 MHz
- Operating voltage of 3.3 V ($\pm 10\%$)
- Pin selectable double drive strength
- Multiple outputs available when combined with Buffalo clock drivers
- Zero input to output skew
- Industrial temperature version available
- Advanced, low power CMOS process

Block Diagram

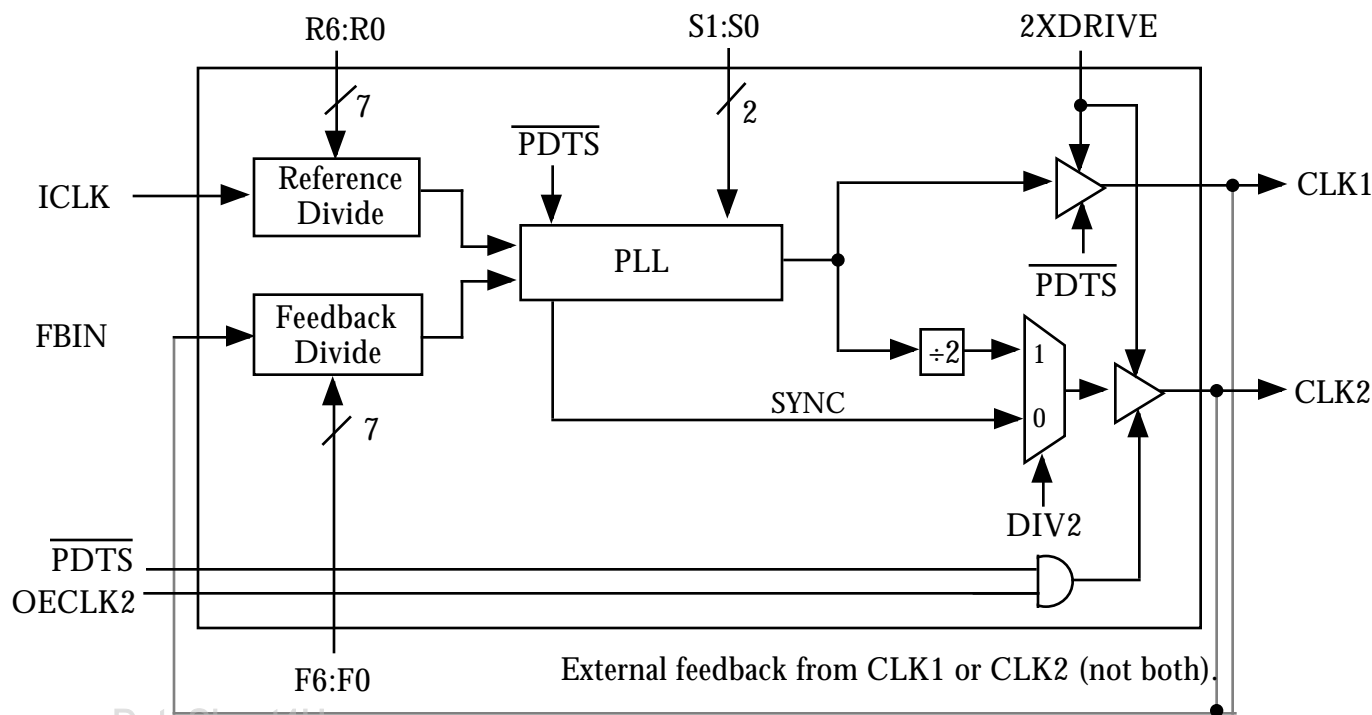



ICS527-01 Clock Slicer™ User Configurable Zero Delay Buffer

Pin Assignment

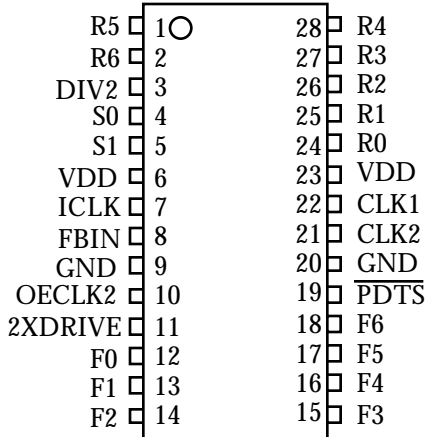

Frequency Configuration Table

S1	S0	CLK1 Output Frequency (MHz)	
pin 5	pin 4	0 to 70°	-40 to 85°
0	0	37 - 75	35 - 70
0	1	18 - 37	16 - 35
1	0	4 - 10	4 - 8
1	1	75 - 160	70 - 140

To cover the range from 10-18 MHz (0-70 °C) and 8-16 (-40-85°C), select address 01 to generate 2x your desired output frequency, then configure CLK2 to generate CLK1/2

CLK2 Operation Table

OECLK2	DIV2	CLK2
0	X	Z
1	0	SYNC
1	1	CLK1/2

Clock Drive Select Table

2XDRIVE	OUTPUT DRIVE
0	12 mA
1	25 mA

Pin Description

Pin #	Name	Type	Description
1, 2, 24-28	R5, R6, R0-R4	I(PU)	Reference divider word input pins determined by user. Forms a binary number from 0 to 127.
3	DIV2	I(PU)	Selects CLK2 function to output a SYNC signal or a divide by 2 of CLK1. See table above.
4, 5	S0, S1	I(PU)	Select pins for output divider determined by user. See table above.
6, 23	VDD	P	Connect to VDD.
7	ICLK	I	Reference clock input.
8	FBIN	I	Feedback clock input.
9, 20	GND	P	Connect to ground.
10	OECLK2	I(PU)	CLK2 Output Enable. CLK2 tri-stated when low.
11	2XDRIVE	I(PU)	Clock output drive strength doubled when high.
12-18	F0-F6	I(PU)	Feedback divider word input pins determined by user. Forms a binary number from 0 to 127.
19	P $\overline{\text{DTS}}$	I(PU)	Power Down. Active low. Turns off entire chip when low. Both Clock outputs tri-stated.
21	CLK2	O	Output Clock 2. Can be the SYNC output or a low skew divide by 2 of CLK1.
22	CLK1	O	Output Clock 1.

Key: I = Input; I(PU) = Input with internal pull-up resistor; O = Output; P = Power supply connection
DataSheet4U.com



Using the Clock Slicer™

First use DIV2 to select the function of the CLK2 output. If DIV2 is high, a divide-by-2, low skew version of CLK1 is present on CLK2. If DIV2 is low, a SYNC pulse is generated on CLK2. The SYNC pulse goes high synchronously with the rising edges of ICLK and CLK1 that are de-skewed. The SYNC function operates at CLK1 frequencies up to 66 MHz. If neither CLK1/2 or a SYNC pulse are required, then CLK2 should be disabled by connecting OECLK2 to ground, which will also give the lowest jitter on CLK1.

Next, the feedback scheme should be chosen. If CLK2 is being used as a SYNC or is tri-stated, then CLK1 must be connected to FBIN. If CLK2 is selected to be CLK1 divided-by-2 (DIV2 = 1, OECLK2 = 1), then either CLK1 or CLK2 must be connected to FBIN. The choice between CLK1 or CLK2 is illustrated by the following example where the device has been configured to generate CLK1 that is twice the frequency on ICLK.

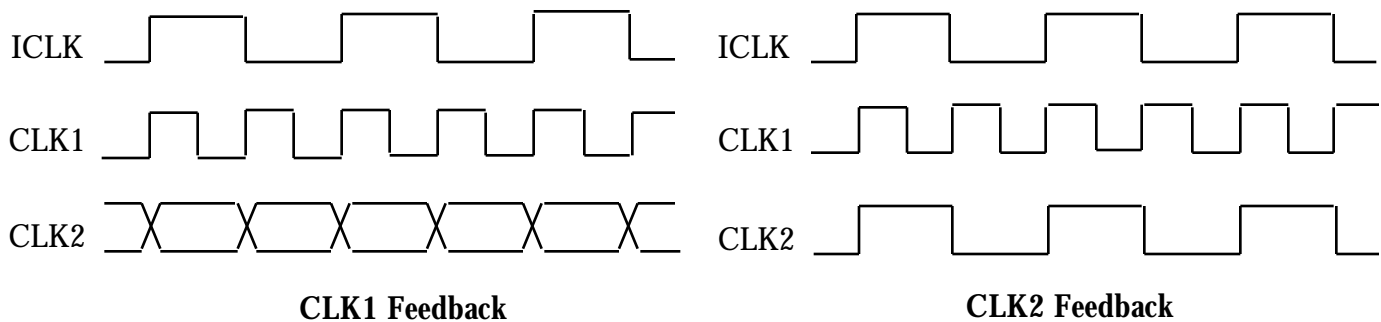

Using CLK1 as the feedback will always result in synchronized rising edges between ICLK and CLK1. But CLK2 could be a falling edge compared with ICLK. Therefore, wherever possible, we recommend the use of CLK2 feedback. This will synchronize the rising edges of all 3 clocks.

More complicated feedback schemes can be used, such as incorporating multiple output buffers in the feedback path. An example of this is given later in the datasheet. The fundamental property of the ICS527-01 is that it aligns rising edges on ICLK and FBIN at a ratio determined by the reference and feedback dividers.

The drive strength is selected by the 2XDRIVE pin. If high drive strength is not required, we recommend tying this pin low.

Lastly, the divider settings should be selected. The following section describes how the dividers can be set.



Determining (setting) the ICS527-01 Dividers

The user has full control in setting the desired output clocks over the range shown in the table on page 2. The user should connect the divider select input pins directly to ground (or VDD, although this is not required because of internal pull-ups) during Printed Circuit Board layout, so that the ICS527-01 automatically produces the correct clock when all components are soldered. It is also possible to connect the inputs to parallel I/O ports to switch frequencies.

The output of the ICS527-01 can be determined by the following simple equation:

$$\text{FB frequency} = \text{Input frequency} \cdot \frac{(\text{FDW}+2)}{(\text{RDW}+2)}$$

Where Reference Divider Word (RDW) = 0 to 127

Feedback Divider Word (FDW) = 0 to 127

FB frequency is the same as either CLK1 or CLK2 depending on feedback connection

Also, the following operating ranges should be observed:

$$300 \text{ kHz} < \frac{\text{Input Frequency}}{(\text{RDW}+2)}$$

The output divide should be selected depending on the frequency of CLK1.

The table on page 2 gives the ranges.

The dividers are expressed as integers. For example, if a 50 MHz output on CLK1 is desired from a 40 MHz input, the reference divider word (RDW) should be 2 and the feedback divider (FDW) should be 3 which gives the required 5/4 multiplication. If multiple choices of divider are available, then the lowest numbers should be used. In this example, the output divide (OD) should be selected to be 2. Then R6:R0 is 0000010, F6:F0 is 0000011 and S1:S0 is 00. Also, this example assumes CLK1 is connected to FBIN.

You may also fax this page to MicroClock/ICS at 408 295-9818, or send an e-mail to ics-mk@icst.com. Be sure to indicate the following:

Your Name _____ Company Name _____ Telephone _____

Respond by e-mail (list your e-mail address) _____ or fax number _____

Desired input clock (in MHz) _____ Desired output frequency _____



Typical Example

The following connection diagram shows the implementation of the example from the previous section. This will generate a 50 MHz clock synchronously with a 40 MHz input. A SYNC pulse is desired and the 1x output drive is selected.

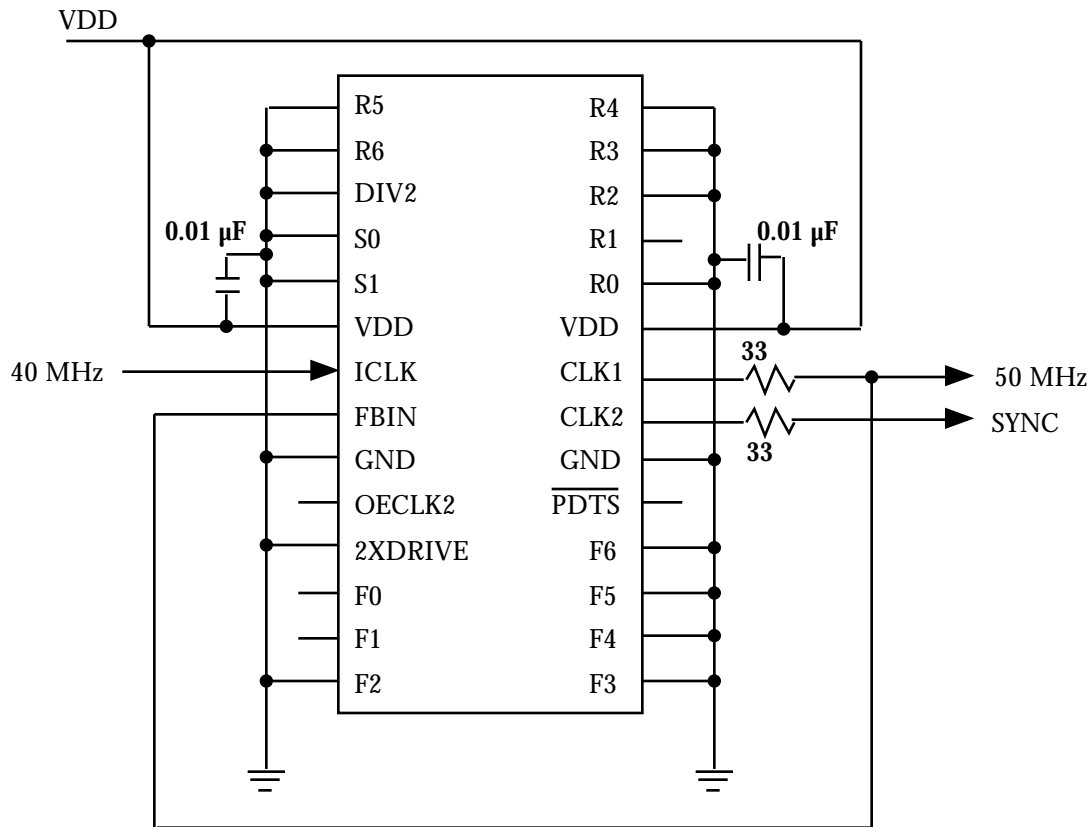

Note that the feedback is done AFTER the series termination resistor.

This will give the following waveforms:

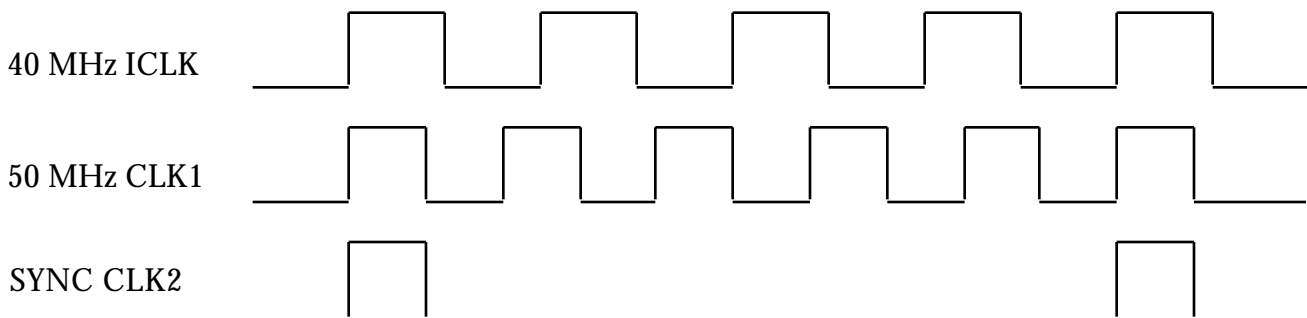



Multiple Output Example

In this example, an input clock of 125 MHz is used. Eight copies of 50 MHz are required as are eight copies of 25 MHz, de-skewed and aligned to the 125 MHz input clock. The following solution uses the MK74CB217 which has dual 1 to 8 buffers with low pin to pin skew.

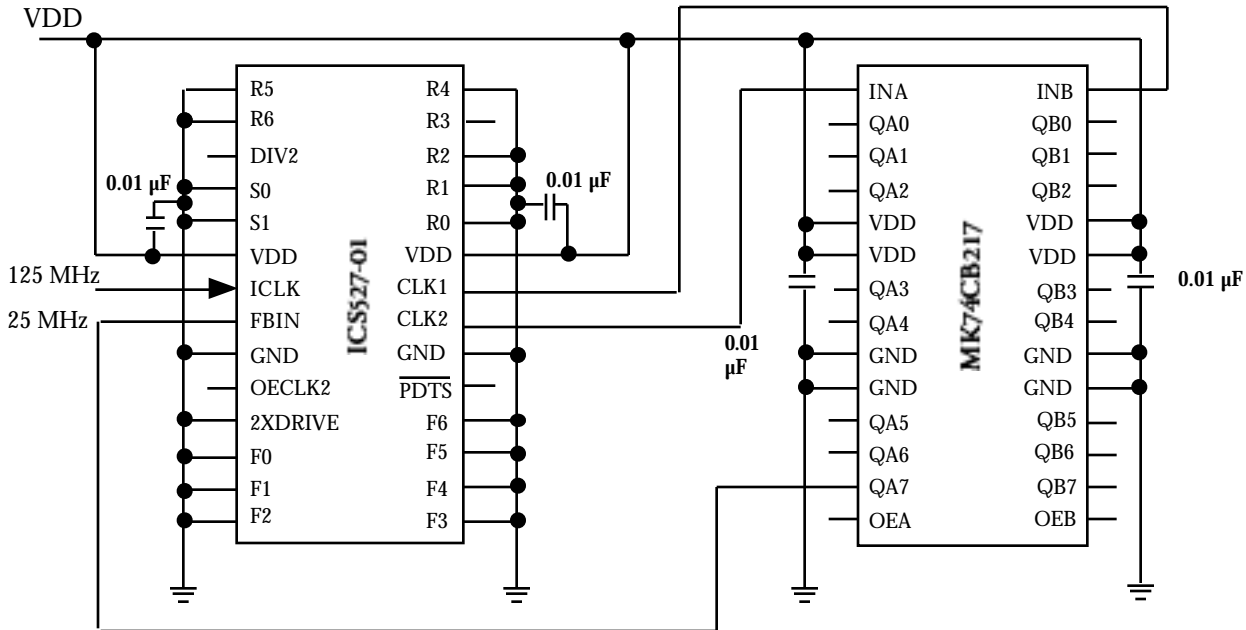

This configuration produces the following waveforms:

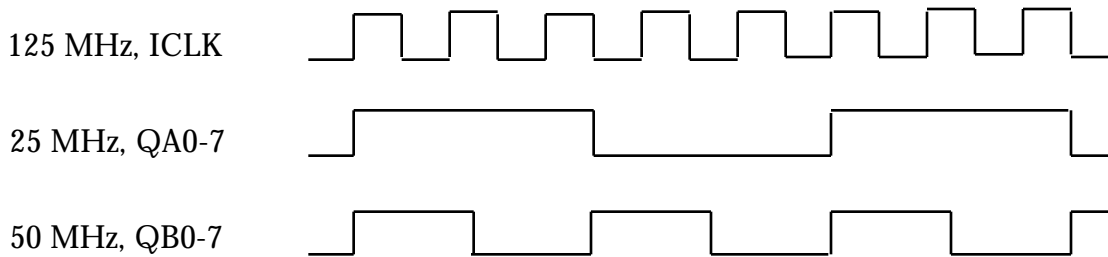

Using the equation for selecting the dividers gives:

$$25 \text{ MHz} = 125 \text{ MHz} \cdot \frac{(FDW + 2)}{(RDW + 2)}$$

If $FDW = 0$, then $RDW = 8$. This gives the required divide-by-5 function. Setting pin $DIV2 = 1$ gives both a 25 MHz and 50 MHz output from the ICS527-01. The $FBIN$ pin is connected to the $QA7$ output of the MK74CB217. This aligns all the outputs of the MK74CB217 with the 125 MHz input since the ICS527-01 aligns rising edges on the $ICLK$ and $FBIN$ pins.

In this example, series termination resistors have been omitted for clarity but should be used on all clock outputs. DataSheet4U.com



User Configurable Zero Delay Buffer

Electrical Specifications

Parameter	Conditions	Minimum	Typical	Maximum	Units
ABSOLUTE MAXIMUM RATINGS (stresses beyond these can permanently damage the device)					
Supply Voltage, VDD	Referenced to GND			7	V
Inputs	Referenced to GND	-0.5		VDD+0.5	V
Clock Output	Referenced to GND	-0.5		VDD+0.5	V
Ambient Operating Temperature	ICS527R-01	0		70	°C
	ICS527R-01I	-40		85	°C
Soldering Temperature	Max of 10 seconds			260	°C
Storage Temperature		-65		150	°C
DC CHARACTERISTICS (VDD = 3.3V unless otherwise noted)					
Operating Voltage, VDD		3		3.6	V
Input High Voltage, VIH		2			V
Input Low Voltage, VIL				0.8	V
Input High Voltage, VIH, ICLK and FBIN	pins 7, 8	(VDD/2)+1			V
Input Low Voltage, VIL, ICLK and FBIN	pins 7, 8			(VDD/2)-1	V
Output High Voltage, VOH (2X DRIVE = 0)	IOH=-12mA	2.4			V
Output Low Voltage, VOL (2X DRIVE = 0)	IOL=12mA			0.4	V
Output High Voltage, VOH (2X DRIVE = 1)	IOH=-25mA	2.4			V
Output Low Voltage, VOL (2X DRIVE = 1)	IOL=25mA			0.4	V
IDD Operating Supply Current, 15 MHz IN	60MHz out, no load		8		mA
IDD Operating Supply Current, Power Down			20		µA
Short Circuit Current (2XDRIVE = 0)	CLK outputs		±70		mA
Short Circuit Current (2XDRIVE = 1)	CLK outputs		±140		mA
On-Chip Pull-up Resistor			270		k
Input Capacitance			4		pF
AC CHARACTERISTICS (VDD = 3.3V unless otherwise noted)					
Input Frequency, clock input		0.6		200	MHz
Output Frequency, CLK1	0 C to 70 °C	4		160	MHz
	-40 C to +85 °C	4		140	MHz
CLK1 Frequency for correct SYNC operation				66	MHz
Output Clock Rise Time	0.8 to 2.0V		1		ns
Output Clock Fall Time	2.0 to 0.8V		1		ns
Output Clock Duty Cycle	at VDD/2, 15 pF load	45	50	55	%
Power Down Time, $\overline{PDT\overline{S}}$ low to clocks tri-stated				50	ns
Power Up Time, $\overline{PDT\overline{S}}$ high to clocks stable				10	ms
Absolute Clock Period Jitter	Deviation from mean		±90		ps
One Sigma Clock Period Jitter			40		ps
Skew of output clocks, CLK1 to CLK2	Note 1	-250	0	250	ps
Input to output skew, ICLK to FBIN	Note 1	-250	0	250	ps
Device to device skew, common ICLK	at FBIN		0	500	ps

Note 1: Assumes clocks with same rise time, measured from rising edges at VDD/2.

www.DataSheet4U.com



External Components

The ICS527-01 requires two 0.01μF decoupling capacitors to be connected between VDD and GND, one on each side of the chip. They must be connected close to the device to minimize lead inductance. No external power supply filtering is required for this device. A 33 series terminating resistor can be used next to the CLK1 and CLK2 pins.

Package Outline and Package Dimensions

(For current dimensional specifications, see JEDEC no. 95.)

28 pin SSOP

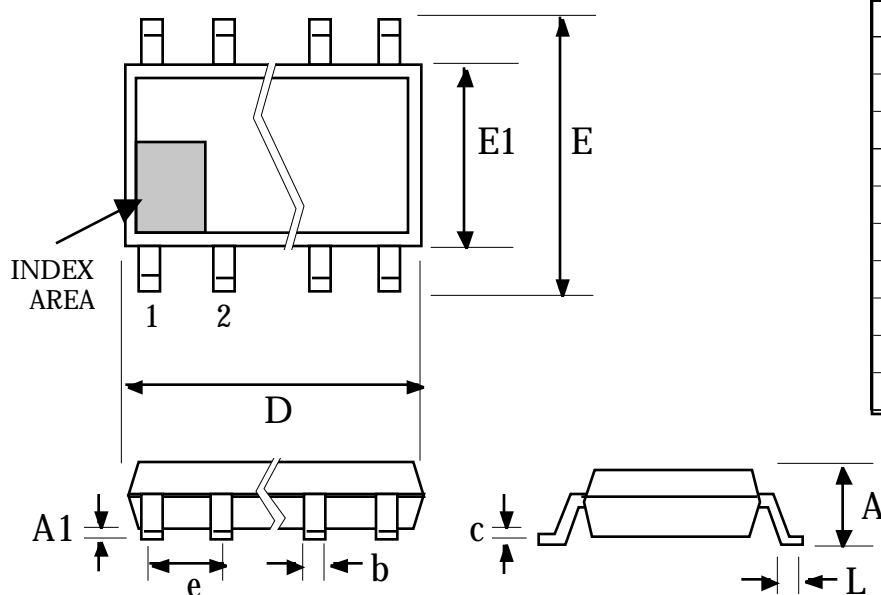

Symbol	Inches		Millimeters	
	Min	Max	Min	Max
A	0.053	0.069	1.35	1.75
A1	0.004	0.010	0.10	0.25
b	0.008	0.012	0.20	0.30
c	0.007	0.010	0.19	0.25
D	0.386	0.394	9.80	10.01
e	.025 BSC		0.635 BSC	
E	0.228	0.244	5.79	6.20
E1	0.150	0.157	3.81	3.99
L	0.016	0.050	0.41	1.27

Ordering Information

Part/Order Number	Marking	Package	Temperature
ICS527R-01	ICS527R-01	28 pin narrow SSOP	0 to 70 °C
ICS527R-01T	ICS527R-01	28 pin SSOP on tape and reel	0 to 70 °C
ICS527R-01I	ICS527R-01I	28 pin narrow SSOP	-40 to 85 °C
ICS527R-01IT	ICS527R-01I	28 pin SSOP on tape and reel	-40 to 85 °C

While the information presented herein has been checked for both accuracy and reliability, Integrated Circuit Systems assumes no responsibility for either its use or for the infringement of any patents or other rights of third parties, which would result from its use. No other circuits, patents, or licenses are implied. This product is intended for use in normal commercial applications. Any other applications such as those requiring extended temperature range, high reliability, or other extraordinary environmental requirements are not recommended without additional processing by ICS. ICS reserves the right to change any circuitry or specifications without notice. ICS does not authorize or warrant any ICS/MicroClock product for use in life support devices or critical medical instruments.

www.DataSheet4U.com