



LOW SKEW 1 TO 4 CLOCK BUFFER PECL IN, PECL OUT

Description

The ICS554-01 is a low skew clock buffer with a single complimentary PECL input to four PECL outputs. Part of ICS' Clock Blocks™ family, this is our lowest skew PECL clock buffer. For parts which do not require PECL inputs or outputs, see the ICS553 for a 1 to 4 low skew buffer, or the ICS552-02 for a 1 to 8 low skew buffer. For more than 8 outputs see the MK74CBxxx Buffalo™ series of clock drivers.

ICS makes many non-PLL and PLL based low skew output devices as well as Zero Delay Buffers to synchronize clocks. Contact us for all of your clocking needs.

Features

- Outputs are skew matched to within 50ps
- Packaged in 16 pin TSSOP
- One PECL input to 4 PECL output clock drivers
- Operating Voltages of 3.3V to 5V

Block Diagram

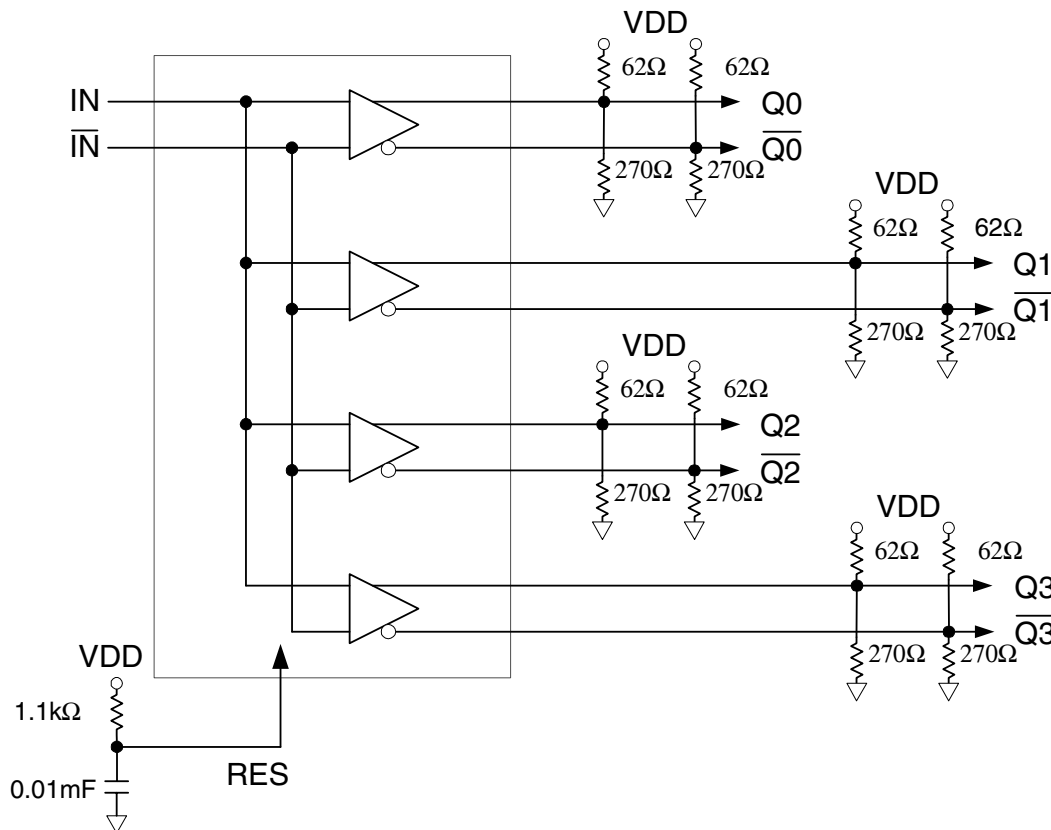



Pin Assignment

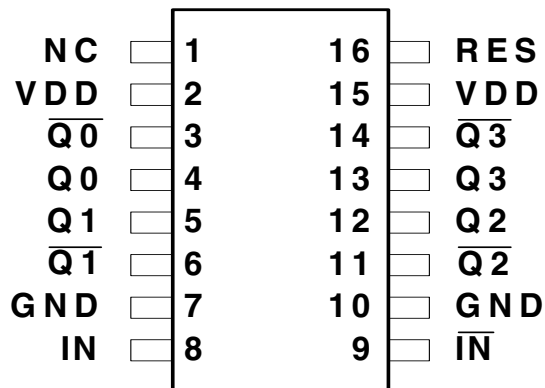

16 Pin TSSOP

Pin Descriptions

Pin Number	Pin Name	Pin Type	Pin Description
1	NC	-	No Connect.
2	VDD	Power	Connect to +2.5 V, +3.3V or +5.0V. Must be the same as pin 15.
3	$\overline{Q0}$	Output	Clock Output $\overline{Q0}$
4	Q0	Output	Clock Output Q0
5	Q1	Output	Clock Output Q1
6	$\overline{Q1}$	Output	Clock Output $\overline{Q1}$
7	GND	Power	Ground
8	IN	Input	PECL Clock Input
9	\overline{IN}	Input	Complementary PECL Clock Input
10	GND	Power	Ground
11	$\overline{Q2}$	Output	Clock Output $\overline{Q2}$
12	Q2	Output	Clock Output Q2
13	Q3	Output	Clock Output Q3
14	$\overline{Q3}$	Output	Clock Output $\overline{Q3}$
15	VDD	Power	Connect to +2.5V, +3.3V or +5.0V. Must be the same as pin 2
16	RES	Input	Bias Resistor Input.



External Components

The ICS554-01 requires a decoupling capacitor of 0.01 μ F to be connected between VDD on pin 2 and GND on pin 7, as well as between VDD on pin 15 and GND on pin 10. These decoupling capacitors should be placed as close to the device as possible. A 0.01 μ F capacitor must be placed between the RES (pin 16) and Ground, also, a resistor must be connected between the RES (pin 16) and VDD. Another eight resistors are needed for the PECL outputs as shown on the block diagram on page 1. Suggested values of these resistors are shown in the Block Diagram, but they can be varied to change the differential pair output swing, and the DC level. Refer to Application Note, MAN09.

To achieve the low output skews that the ICS554-01 is capable of, careful attention must be paid to board layout. Essentially, all 8 outputs must have identical terminations, identical loads, and identical trace geometries. If they do not, the output skew will be degraded. For example, using a 30 Ω series termination on one output (with 33 Ω on the others) will cause at least 15ps of skew.

Absolute Maximum Ratings

Stresses above the ratings listed below can cause permanent damage to the ICS554-01. These ratings, which are standard values for ICS commercially rated parts, are stress ratings only. Functional operation of the device at these or any other conditions above those indicated in the operational sections of the specifications is not implied. Exposure to absolute maximum rating conditions for extended periods can affect product reliability. Electrical parameters are guaranteed only over the recommended operating temperature range.

Item	Rating
Supply Voltage, VDD	7V
All Inputs and Outputs	-0.5V to VDD+0.5V
Ambient Operating Temperature	0 to +70°C
Storage Temperature	-65 to +150°C
Junction Temperature	175°C
Soldering Temperature	260°C

Recommended Operation Conditions

Parameter	Min.	Typ.	Max.	Units
Ambient Operating Temperature	0	–	+70	°C
Power Supply Voltage (measured in respect to GND)	+3.15		+5.25	V



DC Electrical Characteristics

VDD=3.3V \pm 5%, Ambient temperature 0 to +70°C, unless stated otherwise

Parameter	Symbol	Conditions	Min.	Typ.	Max.	Units
Operating Voltage	VDD		3.15		5.25	V
Peak to Peak Input Voltage	IN		0.3		1.0	V
Input Common Mode Range	IN	VDD=3.3V	VDD-2.0		VDD-0.6	V
Input Common Mode Range	IN	VDD=5V	VDD-3.7		VDD-0.6	V
Input High Voltage, OE	V _{IH}	–	2	–	VDD	V
Input Low Voltage, OE	V _{IL}	–	–	–	0.4	V
Output High Voltage	V _{OH}	Note 1	VDD-1.2			V
Output Low Voltage	V _{OL}	Note 1	–	–	VDD-2.0	V
Operating Supply Current	IDD	No load, 135 MHz		67		mA
Short Circuit Current, 2.5V	I _{OS}			\pm 40		mA
Short Circuit Current, 3.3V	I _{OS}			\pm 50		mA
Short Circuit Current, 5V	I _{OS}			\pm 60		mA

Notes: 1. V_{OH} and V_{OL} can be set by the external resistor values on the PECL outputs.

2. IDD includes the current through the external resistors which can be modified.

AC Electrical Characteristics

VDD = 3.3V \pm 5%, Ambient Temperature 0 to +70° C, unless stated otherwise

Parameter	Symbol	Conditions	Min.	Typ.	Max.	Units
Input Frequency			0		200	MHz
Propagation Delay (VDD=3.3V)				4		ns
Propagation Delay (VDD=5V)				3		ns
Output to output skew.		Crossing point of pair		0	50	ps

**Package Outline and Package Dimensions (16 pin TSSOP, 173 Mil. Narrow Body)**

Package dimensions are kept current with JEDEC Publication No. 95

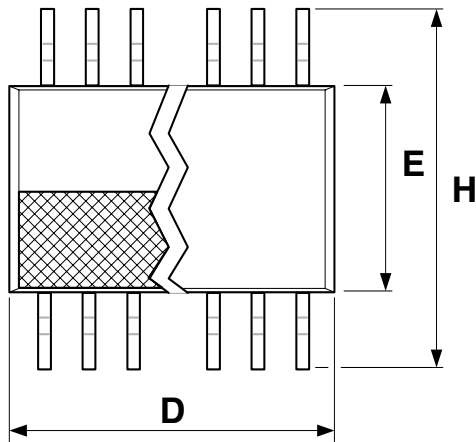

Symbol	Millimeters		Inches	
	Min	Max	Min	Max
A	--	1.20	--	0.047
a	0.05	0.15	0.002	0.006
b	0.19	0.30	0.007	0.012
c	0.09	0.20	0.0035	0.008
D	4.90	5.10	0.193	0.201
E	4.30	4.50	0.169	0.177
e	0.65 Basic		0.0256 Basic	
H	6.40 Basic		0.252 Basic	
L	0.45	0.75	0.018	0.030

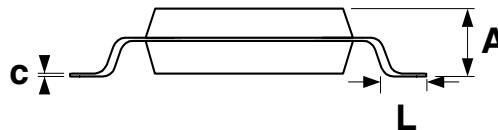
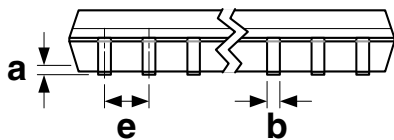
**Ordering Information**

Part / Order Number	Marking (both)	Shipping packaging	Package	Temperature
ICS554G-01	ICS (top line)	Tubes	16 pin TSSOP	0 to +70° C
ICS554G-01T	554G-01 (2nd line)	Tape and Reel	16 pin TSSOP	0 to +70° C

While the information presented herein has been checked for both accuracy and reliability, Integrated Circuit Systems (ICS) assumes no responsibility for either its use or for the infringement of any patents or other rights of third parties, which would result from its use. No other circuits, patents, or licenses are implied. This product is intended for use in normal commercial applications. Any other applications such as those requiring extended temperature range, high reliability, or other extraordinary environmental requirements are not recommended without additional processing by ICS. ICS reserves the right to change any circuitry or specifications without notice. ICS does not authorize or warrant any ICS product for use in life support devices or critical medical instruments.