

GENERAL DESCRIPTION



The ICS83026I-01 is a low skew, 1-to-2 Differential-to-LVCMOS/LVTTL Fanout Buffer and a member of the HiPerClockS™ family of High Performance Clock Solutions from IDT. The differential input can accept most differential signal types (LVPECL, LVDS, LVHSTL, HCSL and SSTL) and translate to two single-ended LVCMOS/LVTTL outputs. The small 8-lead SOIC footprint makes this device ideal for use in applications with limited board space.

www.DataSheet

FEATURES

- Two LVCMOS / LVTTL outputs
- Differential CLK, nCLK input pair
- CLK, nCLK pair can accept the following differential input levels: LVPECL, LVDS, LVHSTL, HCSL, SSTL
- Maximum output frequency: 350MHz
- Output skew: 15ps (maximum)
- Part-to-part skew: 600ps (maximum)
- Additive phase jitter, RMS: 0.03ps (typical)
- Small 8 lead SOIC package saves board space
- 3.3V core, 3.3V, 2.5V or 1.8V output operating supply
- -40°C to 85°C ambient operating temperature
- Available in both standard (RoHS 5) and lead-free RoHS (6) packages

BLOCK DIAGRAM

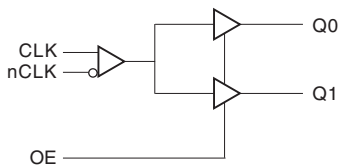

PIN ASSIGNMENT

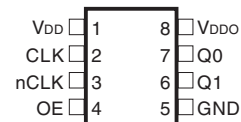

ICS83026I-01 8-Lead SOIC

3.8mm x 4.8mm, x 1.47mm package body

M Package
Top View

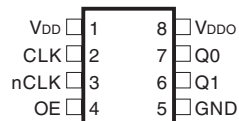

ICS83026I-01 8-Lead TSSOP

4.40mm x 3.0mm x 0.925mm package body

G Package
Top View



TABLE 1. PIN DESCRIPTIONS

Number	Name	Type	Description
1	V _{DD}	Power	Positive supply pin.
2	CLK	Input Pulldown	Non-inverting differential clock input.
3	nCLK	Input Pullup/ Pulldown	Inverting differential clock input. V _{DD} /2 default when left floating.
4	OE	Input Pullup	Output enable. When HIGH, outputs are enabled. When LOW, outputs are in High Impedance State. LVCMOS / LVTTL interface levels.
5	GND	Power	Power supply ground.
6	Q1	Output	Clock output. LVCMOS / LVTTL interface levels.
7	Q0	Output	Clock output. LVCMOS / LVTTL interface levels.
8	V _{DDO}	Power	Output supply pin.

NOTE: Pullup and Pulldown refer to internal input resistors. See Table 2, Pin Characteristics, for typical values.

TABLE 2. PIN CHARACTERISTICS

Symbol	Parameter	Test Conditions	Minimum	Typical	Maximum	Units
C _{IN}	Input Capacitance			4		pF
C _{PD}	Power Dissipation Capacitance (per output)	V _{DD} , V _{DDO} = 3.465V			17	pF
		V _{DD} = 3.465V, V _{DDO} = 2.625V			16	pF
		V _{DD} = 3.465V, V _{DDO} = 1.95V			15	pF
R _{PULLUP}	Input Pullup Resistor			51		kΩ
R _{PULLDOWN}	Input Pulldown Resistor			51		kΩ
R _{OUT}	Output Impedance	V _{DD} , V _{DDO} = 3.3V		7		Ω
		V _{DD} = 3.3V, V _{DDO} = 2.5V		8		Ω
		V _{DD} = 3.3V, V _{DDO} = 1.8V		10		Ω

TABLE 3. CONTROL FUNCTION TABLE

Input	Outputs
OE	Q0, Q1
0	HiZ
1	Active



ICS83026I-01

LOW SKEW, 1-TO-2

DIFFERENTIAL-TO-LVCMOS/LVTTL FANOUT BUFFER

ABSOLUTE MAXIMUM RATINGS

Supply Voltage, V_{DD}	4.6V
Inputs, V_I	-0.5V to $V_{DD} + 0.5V$
Outputs, V_O	-0.5V to $V_{DDO} + 0.5V$
Package Thermal Impedance, θ_{JA}	
8 Lead SOIC	112.7°C/W (0 lfpm)
8 Lead TSSOP	101.7°C/W (0 lfpm)
Storage Temperature, T_{STG}	-65°C to 150°C

NOTE: Stresses beyond those listed under Absolute Maximum Ratings may cause permanent damage to the device. These ratings are stress specifications only. Functional operation of product at these conditions or any conditions beyond those listed in the *DC Characteristics* or *AC Characteristics* is not implied. Exposure to absolute maximum rating conditions for extended periods may affect product reliability.

TABLE 3A. POWER SUPPLY DC CHARACTERISTICS, $V_{DD} = 3.3V \pm 5\%$, $V_{DDO} = 1.71V$ TO $3.465V$, $T_A = -40^\circ C$ TO $85^\circ C$

Symbol	Parameter	Test Conditions	Minimum	Typical	Maximum	Units
V_{DD}	Positive Supply Voltage		3.135	3.3	3.465	V
V_{DDO}	Output Supply Voltage		3.135	3.3	3.465	V
			2.375	2.5	2.625	V
			1.71	1.8	1.89	V
I_{DD}	Power Supply Current				10	mA
I_{DDO}	Output Supply Current				3	mA

TABLE 3B. LVCMOS / LVTTL DC CHARACTERISTICS, $V_{DD} = 3.3V \pm 5\%$, $V_{DDO} = 2.375V$ TO $3.465V$, $T_A = -40^\circ C$ TO $85^\circ C$

Symbol	Parameter	Test Conditions	Minimum	Typical	Maximum	Units
V_{IH}	Input High Voltage	OE	2		$V_{DD} + 0.3$	V
V_{IL}	Input Low Voltage	OE	-0.3		0.8	V
I_{IH}	Input High Current	OE	$V_{DD} = V_{IN} = 3.465V$		5	μA
I_{IL}	Input Low Current	OE	$V_{DD} = 3.465V, V_{IN} = 0V$		-150	μA
V_{OH}	Output High Voltage; NOTE 1		$V_{DDO} = 3.135V$		2.6	V
			$V_{DDO} = 2.375V$		1.8	V
V_{OL}	Output Low Voltage; NOTE 1				0.5	V

NOTE 1: Outputs terminated with 50Ω to $V_{DDO}/2$. See Parameter Measurement Information section, "Output Load Test Circuit" diagrams.

TABLE 3C. LVCMOS / LVTTL DC CHARACTERISTICS, $V_{DD} = 3.3V \pm 5\%$, $V_{DDO} = 1.8V \pm 5\%$, $T_A = -40^\circ C$ TO $85^\circ C$

Symbol	Parameter	Test Conditions	Minimum	Typical	Maximum	Units
V_{IH}	Input High Voltage	OE	2		$V_{DD} + 0.3$	V
V_{IL}	Input Low Voltage	OE	-0.3		0.8	V
I_{IH}	Input High Current	OE	$V_{DD} = V_{IN} = 3.465V$		5	μA
I_{IL}	Input Low Current	OE	$V_{DD} = 3.465V, V_{IN} = 0V$		-150	μA
V_{OH}	Output High Voltage		$I_{OH} = -100\mu A$	$V_{DDO} - 0.2$		V
			$I_{OH} = -2mA$	$V_{DDO} - 0.45$		V
V_{OL}	Output Low Voltage		$I_{OL} = 100\mu A$		0.2	V
			$I_{OL} = 2mA$		0.45	V



TABLE 3D. DIFFERENTIAL DC CHARACTERISTICS, $V_{DD} = 3.3V \pm 5\%$, $V_{DDO} = 1.71V$ TO $3.465V$, $T_A = -40^{\circ}C$ TO $85^{\circ}C$

Symbol	Parameter	Test Conditions	Minimum	Typical	Maximum	Units
I_{IH}	Input High Current	nCLK	$V_{IN} = V_{DD} = 3.465V$		150	μA
		CLK	$V_{IN} = V_{DD} = 3.465V$		150	μA
I_{IL}	Input Low Current	nCLK	$V_{IN} = 0V, V_{DD} = 3.465V$	-150		μA
		CLK	$V_{IN} = 0V, V_{DD} = 3.465V$	-5		μA
V_{PP}	Peak-to-Peak Input Voltage; NOTE 1		0.15		1.3	V
V_{CMR}	Common Mode Input Voltage; NOTE 2, 3		GND + 0.5		$V_{DD} - 0.85$	V

NOTE 1: V_{PP} can exceed 1.3V provided that there is sufficient offset level to keep $V_{IL} > 0V$.

NOTE 2: For single ended applications, the maximum input voltage for CLK, nCLK is $V_{DD} + 0.3V$.

NOTE 3: Common mode voltage is defined as V_{IH} .

TABLE 4A. AC CHARACTERISTICS, $V_{DD} = 3.3V \pm 5\%$, $V_{DDO} = 3.3V \pm 5\%$, $T_A = -40^{\circ}C$ TO $85^{\circ}C$

Symbol	Parameter	Test Conditions	Minimum	Typical	Maximum	Units
f_{MAX}	Output Frequency				350	MHz
t_{PD}	Propagation Delay; NOTE 1	$f \leq 350MHz$	1.3	1.9	2.5	ns
$t_{sk(o)}$	Output Skew; NOTE 2, 4				15	ps
$t_{sk(pp)}$	Part-to-Part Skew; NOTE 3, 4				900	ps
f_{jit}	Buffer Additive Phase Jitter, RMS, refer to Additive Phase Jitter Section			0.03		ps
t_R / t_F	Output Rise/Fall Time	20% to 80%	150		800	ps
odc	Output Duty Cycle	$f \leq 66MHz$	48		52	%
		$67MHz \leq f \leq 166MHz$	45		55	%
		$167MHz \leq f \leq 350MHz$	40		60	%

NOTE 1: Measured from the differential input crossing point to $V_{DDO}/2$ of the output.

NOTE 2: Defined as skew between outputs at the same supply voltage and with equal load conditions.

Measured at $V_{DDO}/2$.

NOTE 3: Defined as skew between outputs on different devices operating at the same supply voltages and with equal load conditions. Using the same type of inputs on each device, the outputs are measured at $V_{DDO}/2$.

NOTE 4: This parameter is defined in accordance with JEDEC Standard 6.



TABLE 4B. AC CHARACTERISTICS, $V_{DD} = 3.3V \pm 5\%$, $V_{DDO} = 2.5V \pm 5\%$, $T_A = -40^{\circ}C$ TO $85^{\circ}C$

Symbol	Parameter	Test Conditions	Minimum	Typical	Maximum	Units
f_{MAX}	Output Frequency				350	MHz
t_{PD}	Propagation Delay; NOTE 1	$f \leq 350MHz$	1.5	2.0	2.6	ns
$tsk(o)$	Output Skew; NOTE 2, 4				15	ps
$tsk(pp)$	Part-to-Part Skew; NOTE 3, 4				750	ps
f_{jit}	Buffer Additive Phase Jitter, RMS, refer to Additive Phase Jitter Section			0.03		ps
t_R / t_F	Output Rise/Fall Time	20% to 80%	150		800	ps
odc	Output Duty Cycle	$f \leq 66MHz$	48		52	%
		$67MHz \leq f \leq 166MHz$	46		54	%
		$167MHz \leq f \leq 350MHz$	40		60	%

NOTE 1: Measured from the differential input crossing point to $V_{DDO}/2$ of the output.

NOTE 2: Defined as skew between outputs at the same supply voltage and with equal load conditions.

Measured at $V_{DDO}/2$.

NOTE 3: Defined as skew between outputs on different devices operating at the same supply voltages and with equal load conditions. Using the same type of inputs on each device, the outputs are measured at $V_{DDO}/2$.

NOTE 4: This parameter is defined in accordance with JEDEC Standard 65.

TABLE 4C. AC CHARACTERISTICS, $V_{DD} = 3.3V \pm 5\%$, $V_{DDO} = 1.8V \pm 5\%$, $T_A = -40^{\circ}C$ TO $85^{\circ}C$

Symbol	Parameter	Test Conditions	Minimum	Typical	Maximum	Units
f_{MAX}	Output Frequency				350	MHz
t_{PD}	Propagation Delay; NOTE 1	$f \leq 350MHz$	1.9	2.5	3.1	ns
$tsk(o)$	Output Skew; NOTE 2, 4				15	ps
$tsk(pp)$	Part-to-Part Skew; NOTE 3, 4				600	ps
f_{jit}	Buffer Additive Phase Jitter, RMS, refer to Additive Phase Jitter Section			0.03		ps
t_R / t_F	Output Rise/Fall Time	20% to 80%	200		900	ps
odc	Output Duty Cycle	$f \leq 66MHz$	48		52	%
		$67MHz \leq f \leq 166MHz$	43		57	%
		$167MHz \leq f \leq 350MHz$	40		60	%

NOTE 1: Measured from the differential input crossing point to $V_{DDO}/2$ of the output.

NOTE 2: Defined as skew between outputs at the same supply voltage and with equal load conditions.

Measured at $V_{DDO}/2$.

NOTE 3: Defined as skew between outputs on different devices operating at the same supply voltages and with equal load conditions. Using the same type of inputs on each device, the outputs are measured at $V_{DDO}/2$.

NOTE 4: This parameter is defined in accordance with JEDEC Standard 65.

ADDITIVE PHASE JITTER

The spectral purity in a band at a specific offset from the fundamental compared to the power of the fundamental is called the **dBc Phase Noise**. This value is normally expressed using a Phase noise plot and is most often the specified plot in many applications. Phase noise is defined as the ratio of the noise power present in a 1Hz band at a specified offset from the fundamental frequency to the power value of the fundamental. This ratio is expressed in decibels (dBm) or a ratio of the power in

the 1Hz band to the power in the fundamental. When the required offset is specified, the phase noise is called a **dBc** value, which simply means dBm at a specified offset from the fundamental. By investigating jitter in the frequency domain, we get a better understanding of its effects on the desired application over the entire time record of the signal. It is mathematically possible to calculate an expected bit error rate given a phase noise plot.

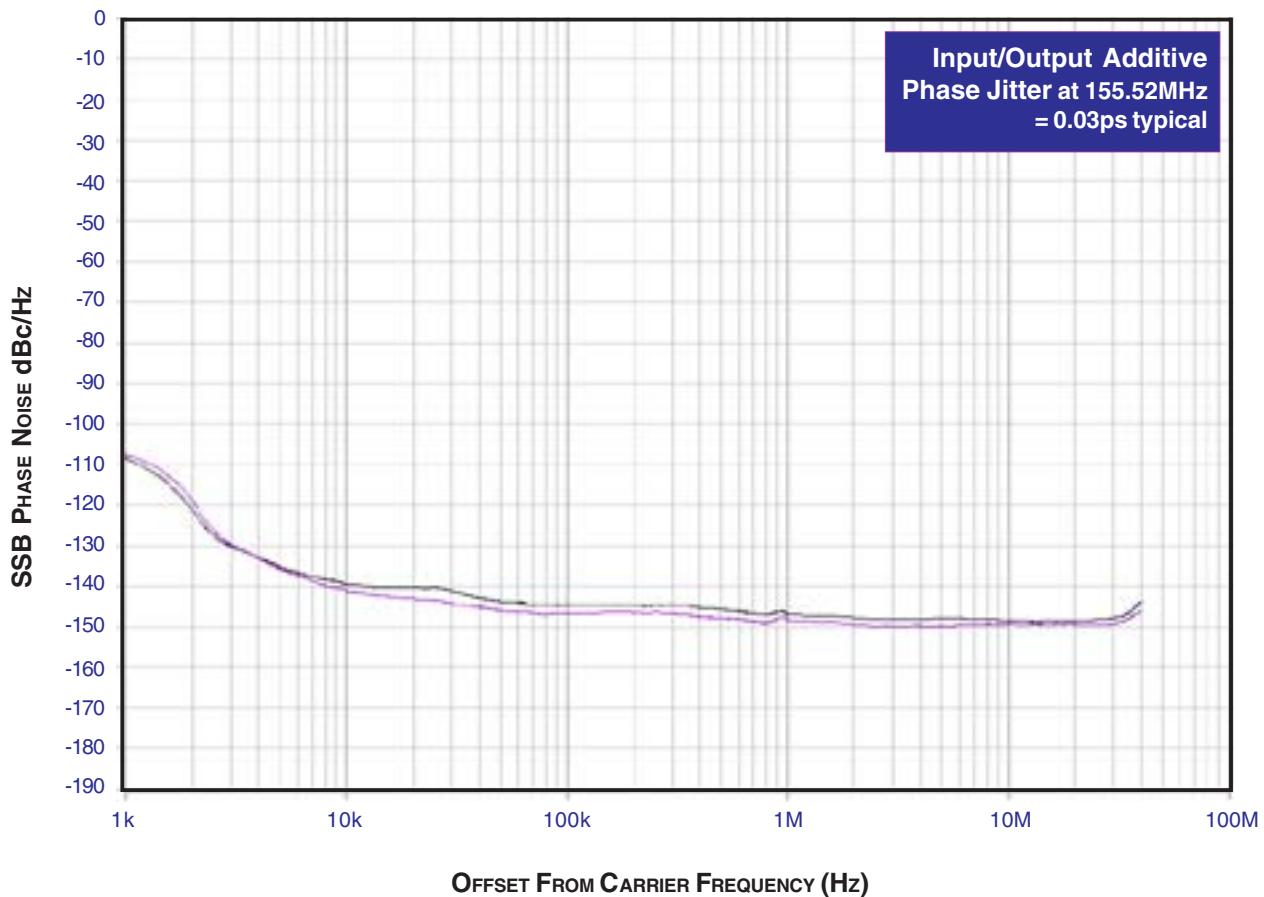

As with most timing specifications, phase noise measurements have issues. The primary issue relates to the limitations of the equipment. Often the noise floor of the equipment is higher than the noise floor of the device. This is illustrated above. The de-

vice meets the noise floor of what is shown, but can actually be lower. The phase noise is dependant on the input source and measurement equipment.

PARAMETER MEASUREMENT INFORMATION

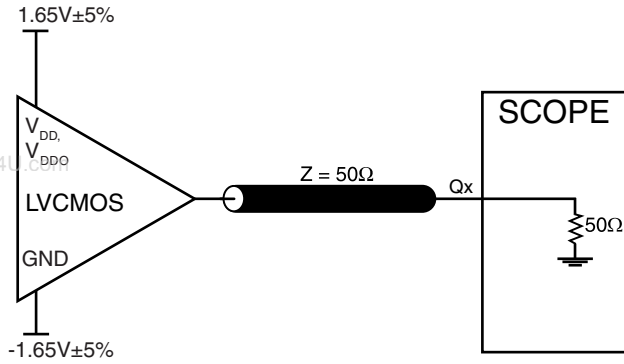

3.3V CORE/3.3V OUTPUT LOAD AC TEST CIRCUIT

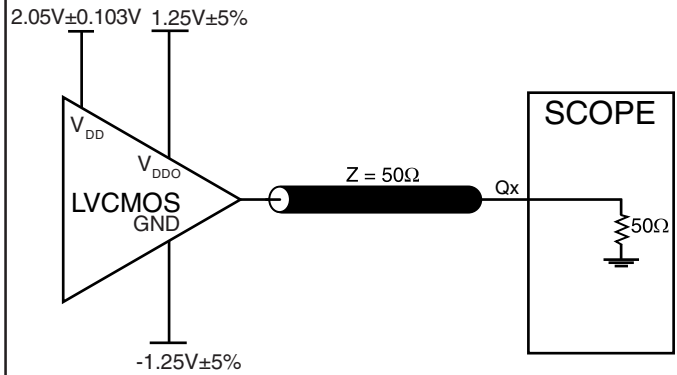

3.3V CORE/2.5V OUTPUT LOAD AC TEST CIRCUIT

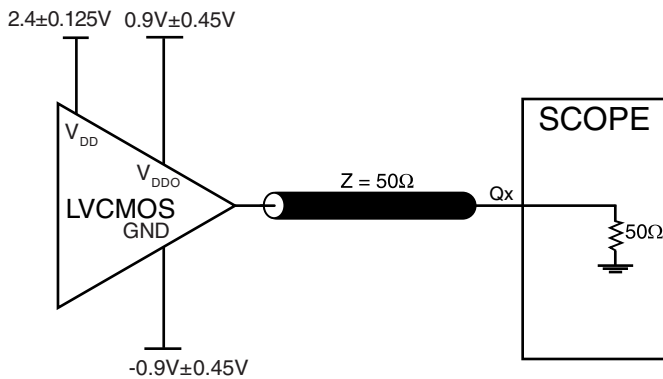

3.3V CORE/1.8V OUTPUT LOAD AC TEST CIRCUIT

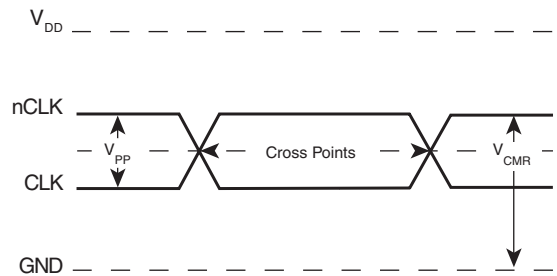

DIFFERENTIAL INPUT LEVEL

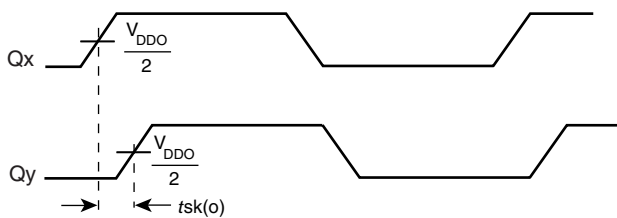

OUTPUT SKEW

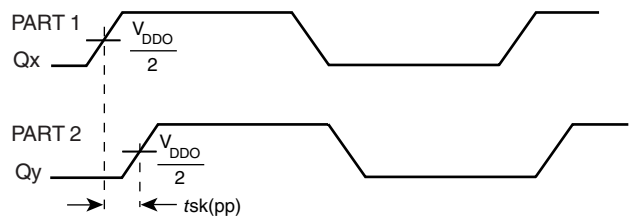

PART-TO-PART SKEW

www.DataSheet4U.com

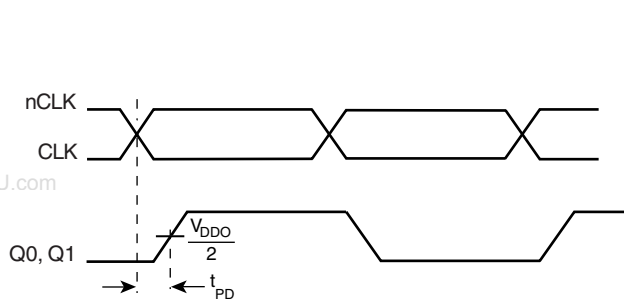

PROPAGATION DELAY

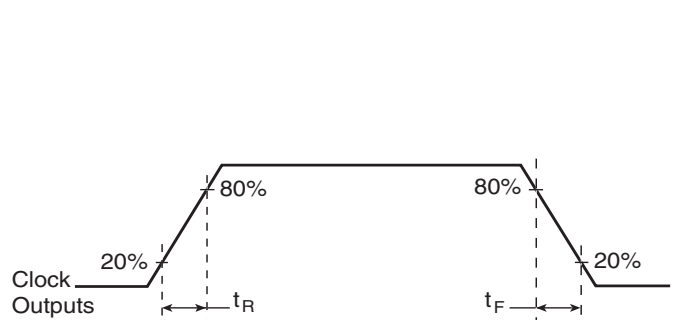

OUTPUT RISE/FALL TIME

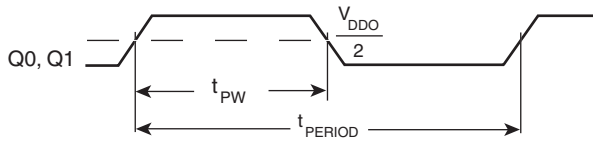

$$\text{odc} = \frac{t_{\text{PW}}}{t_{\text{PERIOD}}} \times 100\%$$

OUTPUT DUTY CYCLE/PULSE WIDTH/PERIOD

APPLICATION INFORMATION

WIRING THE DIFFERENTIAL INPUT TO ACCEPT SINGLE ENDED LEVELS

Figure 1 shows how the differential input can be wired to accept single ended levels. The reference voltage $V_{REF} = V_{DD}/2$ is generated by the bias resistors R1, R2 and C1. This bias circuit should be located as close as possible to the input pin. The ratio

of R1 and R2 might need to be adjusted to position the V_{REF} in the center of the input voltage swing. For example, if the input clock swing is only 2.5V and $V_{DD} = 3.3V$, V_{REF} should be 1.25V and $R2/R1 = 0.609$.

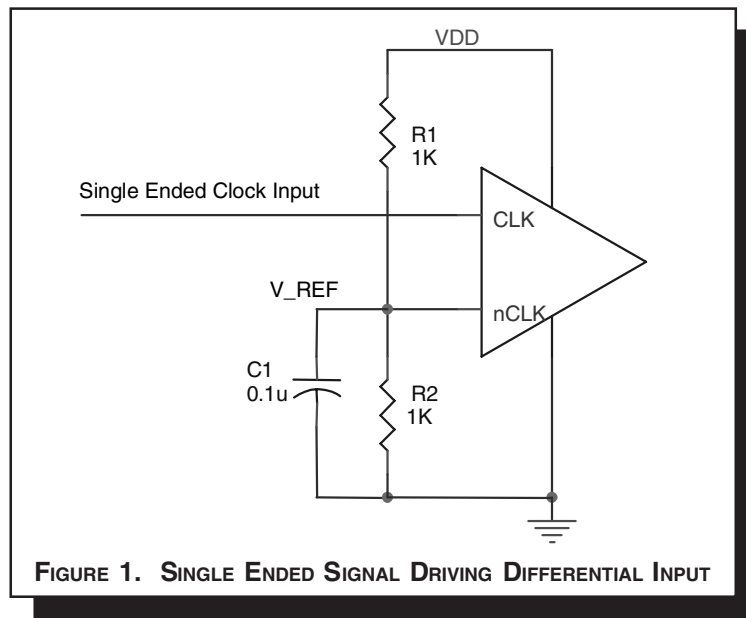

RECOMMENDATIONS FOR UNUSED OUTPUT PINS

OUTPUTS:

LVCMOS OUTPUTS

All unused LVCMOS output can be left floating. We recommend that there is no trace attached.

DIFFERENTIAL CLOCK INPUT INTERFACE

The CLK /nCLK accepts LVDS, LVPECL, LVHSTL, SSTL, HCSSL and other differential signals. Both V_{SWING} and V_{OH} must meet the V_{PP} and V_{CMR} input requirements. Figures 2A to 2E show interface examples for the HiPerClockS CLK/nCLK input driven by the most common driver types. The input interfaces suggested

here are examples only. Please consult with the vendor of the driver component to confirm the driver termination requirements. For example in *Figure 2A*, the input termination applies for ICS HiPerClockS LVHSTL drivers. If you are using an LVHSTL driver from another vendor, use their termination recommendation.

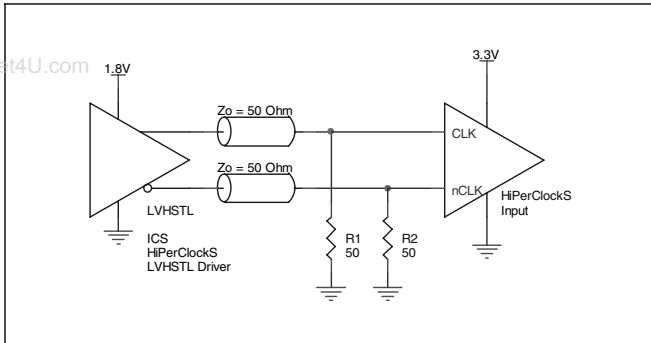

FIGURE 2A. HiPerClockS CLK/nCLK INPUT DRIVEN BY ICS HiPerClockS LVHSTL DRIVER

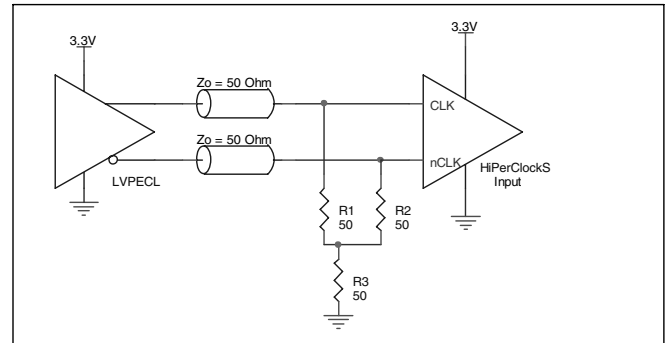

FIGURE 2B. HiPerClockS CLK/nCLK INPUT DRIVEN BY 3.3V LVPECL DRIVER

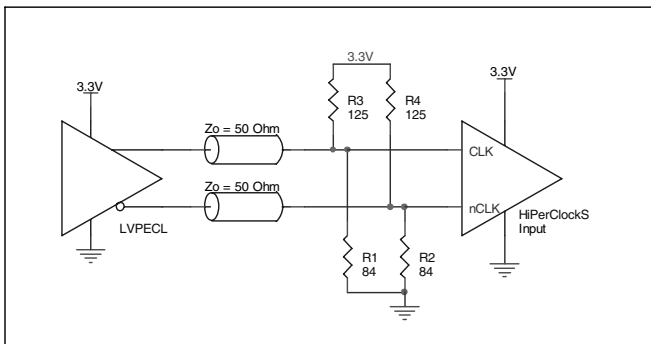

FIGURE 2C. HiPerClockS CLK/nCLK INPUT DRIVEN BY 3.3V LVPECL DRIVER

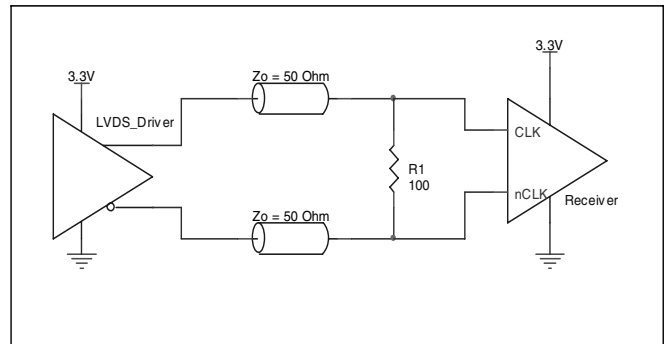

FIGURE 2D. HiPerClockS CLK/nCLK INPUT DRIVEN BY 3.3V LVDS DRIVER

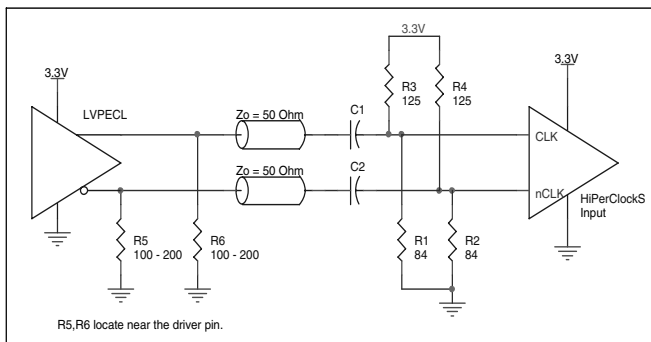

FIGURE 2E. HiPerClockS CLK/nCLK INPUT DRIVEN BY 3.3V LVPECL DRIVER WITH AC COUPLE

SCHEMATIC EXAMPLE

Figure 3 shows an application schematic example of ICS83026I-01. The ICS83026I-01 CLK/nCLK input can directly accept various types of differential signal. In this example, the input is driven by an LVDS driver. The ICS83026I-01 outputs are

LVCMOS drivers. In this example, series termination approach is shown. Additional termination approaches are shown in the LVCMOS Termination Application Note.

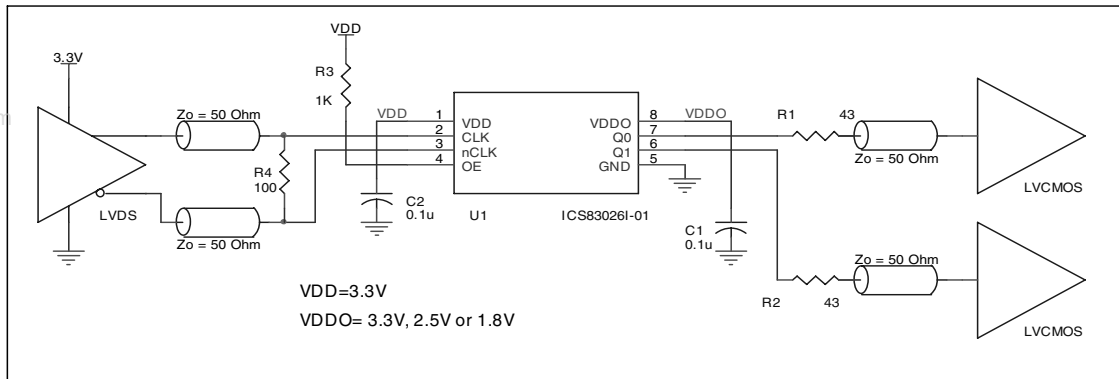

FIGURE 3. ICS83026I-01 SCHEMATIC EXAMPLE

RELIABILITY INFORMATION

TABLE 5A. θ_{JA} VS. AIR FLOW TABLE FOR 8 LEAD SOIC

θ_{JA} by Velocity (Linear Feet per Minute)			
	0	200	500
Single-Layer PCB, JEDEC Standard Test Boards	153.3°C/W	128.5°C/W	115.5°C/W
Multi-Layer PCB, JEDEC Standard Test Boards	112.7°C/W	103.3°C/W	97.1°C/W

NOTE: Most modern PCB designs use multi-layered boards. The data in the second row pertains to most designs.

TABLE 5B. θ_{JA} VS. AIR FLOW TABLE FOR 8 LEAD TSSOP

θ_{JA} by Velocity (Linear Feet per Minute)			
	0	200	500
Multi-Layer PCB, JEDEC Standard Test Boards	101.7°C/W	90.5°C/W	89.8°C/W

TRANSISTOR COUNT

The transistor count for ICS83026I-01 is: 260

PACKAGE OUTLINE - SUFFIX M FOR 8 LEAD SOIC

PACKAGE OUTLINE - G SUFFIX FOR 8 LEAD TSSOP

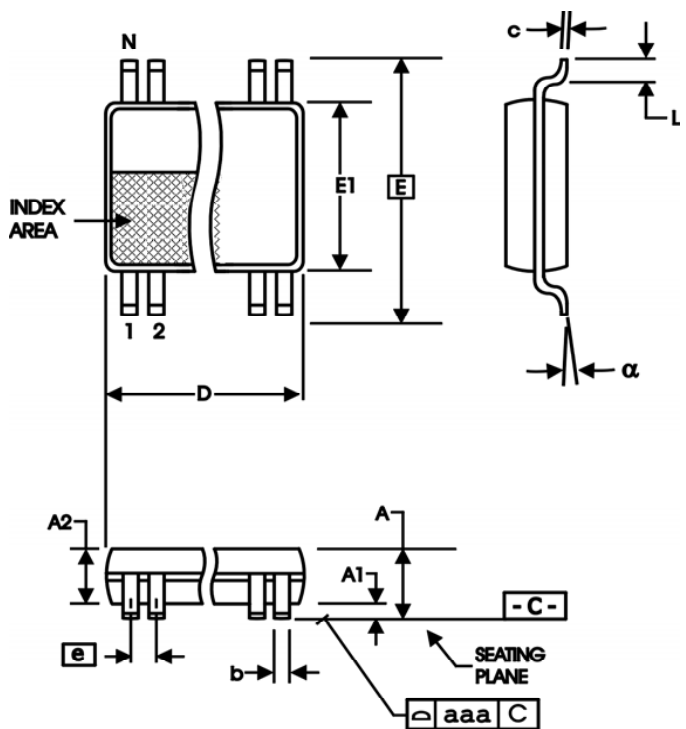
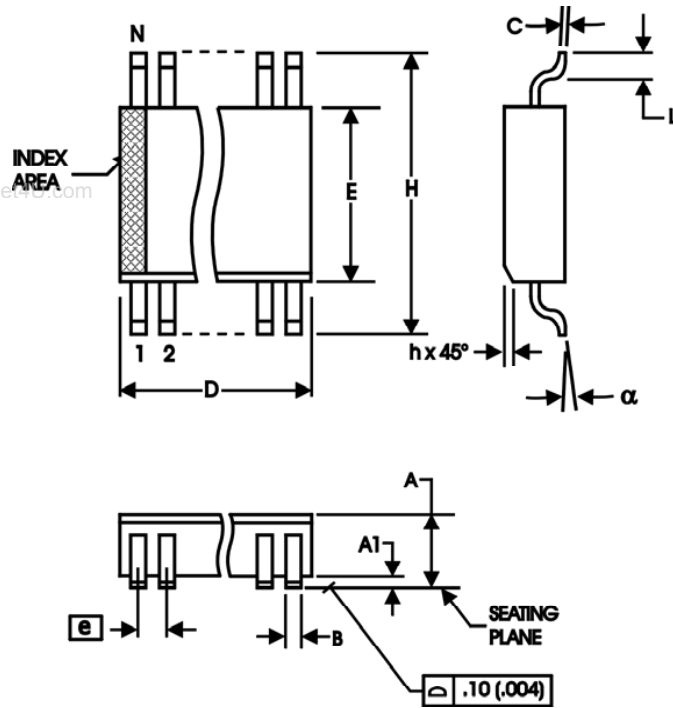

TABLE 6A. PACKAGE DIMENSIONS

SYMBOL	Millimeters	
	MINIMUM	MAXIMUM
N	8	
A	1.35	1.75
A1	0.10	0.25
B	0.33	0.51
C	0.19	0.25
D	4.80	5.00
E	3.80	4.00
e	1.27 BASIC	
H	5.80	6.20
h	0.25	0.50
L	0.40	1.27
α	0°	8°

Reference Document: JEDEC Publication 95, MS-012

TABLE 6B. PACKAGE DIMENSIONS

SYMBOL	Millimeters	
	Minimum	Maximum
N	8	
A	--	1.20
A1	0.05	0.15
A2	0.80	1.05
b	0.19	0.30
c	0.09	0.20
D	2.90	3.10
E	6.40 BASIC	
E1	4.30	4.50
e	0.65 BASIC	
L	0.45	0.75
α	0°	8°
aaa	--	0.10

Reference Document: JEDEC Publication 95, MO-153



ICS83026I-01

LOW SKEW, 1-TO-2

DIFFERENTIAL-TO-LVCMOS/LVTTL FANOUT BUFFER

TABLE 7. ORDERING INFORMATION

Part/Order Number	Marking	Package	Shipping Packaging	Temperature
ICS83026BMI-01	3026BI01	8 lead SOIC	tube	-40°C to 85°C
ICS83026BMI-01T	3026BI01	8 lead SOIC	2500 tape & reel	-40°C to 85°C
ICS83026BMI-01LF	026BI01L	8 lead "Lead-Free" SOIC	tube	-40°C to 85°C
ICS83026BMI-01LFT	026BI01L	8 lead "Lead-Free" SOIC	2500 tape & reel	-40°C to 85°C
ICS83026BGI-01	26B01	8 lead TSSOP	tube	-40°C to 85°C
ICS83026BGI-01T	26B01	8 lead TSSOP	2500 tape & reel	-40°C to 85°C
ICS83026BGI-01LF	BI01L	8 lead "Lead-Free" TSSOP	tube	-40°C to 85°C
ICS83026BGI-01LFT	BI01L	8 lead "Lead-Free" TSSOP	2500 tape & reel	-40°C to 85°C

NOTE: Parts that are ordered with an "LF" suffix to the part number are the Pb-Free configuration and are RoHS compliant.

While the information presented herein has been checked for both accuracy and reliability, Integrated Device Technology, Incorporated (IDT) assumes no responsibility for either its use or for infringement of any patents or other rights of third parties, which would result from its use. No other circuits, patents, or licenses are implied. This product is intended for use in normal commercial applications. Any other applications such as those requiring extended temperature ranges, high reliability or other extraordinary environmental requirements are not recommended without additional processing by IDT. IDT reserves the right to change any circuitry or specifications without notice. IDT does not authorize or warrant any IDT product for use in life support devices or critical medical instruments.



ICS83026I-01

LOW SKEW, 1-TO-2

DIFFERENTIAL-TO-LVCMOS/LVTTL FANOUT BUFFER

REVISION HISTORY SHEET				
Rev	Table	Page	Description of Change	Date
A	T7	1	Added 8 Lead TSSOP package to Pin Assignment.	6/25/04
		3	Absolute Maximum Ratings - added 8 Lead TSSOP to Package Thermal Impedance.	
		11	Added 8 Lead TSSOP Reliability Information table.	
		12	Added 8 Lead TSSOP Package Outline and Package Dimensions.	
		13	Ordering Information Table - added 8 Lead TSSOP ordering information.	
A		6	Additive Phase Jitter - corrected X axis on plot.	8/2/05
A	T3C	3	LVCMOS DC Characteristics - corrected Test Conditions for IIH and IIL.	8/12/05
A	T7	1	Features Section - added lead-free bullet	1/16/06
		9	Added <i>Recommendations for Unused Output Pins</i> .	
		13	Ordering Information Table - added lead-free part number, marking, and note.	
A	T7	13	Ordering Information Table - added lead-free marking	10/22/07