



### GENERAL DESCRIPTION



The ICS8343-01 is a low skew, 1-to-16 LVCMOS/LVTTTL Fanout Buffer and a member of the HiPerClockS™ family of High Performance Clock Solutions from ICS. The ICS8343-01 single ended clock input accepts LVCMOS or LVTTTL input levels.

The ICS8343-01 operates at 3.3V, 2.5V and mixed 3.3V input and 2.5V supply modes over the commercial temperature range. Guaranteed output and part-to-part skew characteristics make the ICS8343-01 ideal for those clock distribution applications demanding well defined performance and repeatability.

### FEATURES

- 16 LVCMOS/LVTTTL outputs
- 1 LVCMOS/LVTTTL clock input
- CLK can accept the following input levels: LVCMOS, LVTTTL
- Maximum output frequency: 200MHz
- Dual output enable inputs facilitates 1-to-16 or 1-to-8 input to output modes
- All inputs are 5V tolerant
- Output skew: 250ps (maximum)
- Part-to-part skew: 700ps (maximum)
- Full 3.3V and 2.5V or mixed 3.3V core/2.5V operating supply
- 0°C to 70°C ambient operating temperature
- Lead-Free package available
- Industrial temperature information available upon request

### BLOCK DIAGRAM

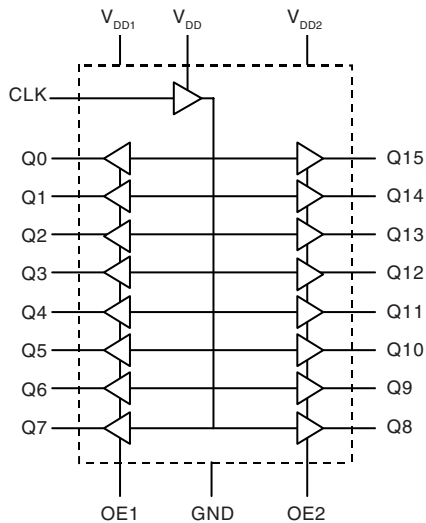

### PIN ASSIGNMENT

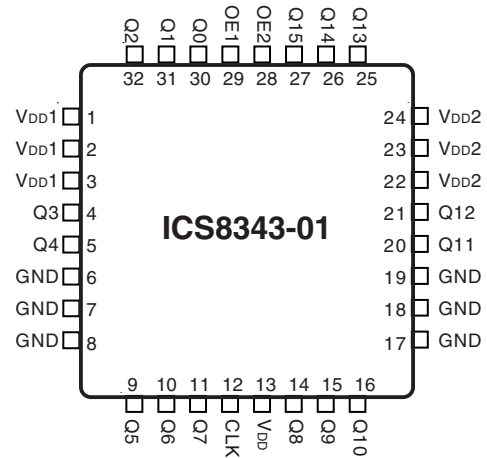

**32-Lead LQFP**  
7mm x 7mm x 1.4mm body package  
**Y Package**  
(Top View)

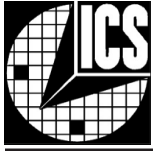

**TABLE 1. PIN DESCRIPTIONS**

Number	Name	Type		Description
1, 2, 3	$V_{DD1}$	Power		Q0 thru Q7 output supply pins.
4, 5	Q3, Q4	Output		LVCMOS/LVTTTL clock outputs. 7 $\Omega$ typical output impedance.
6, 7, 8, 17, 18, 19	GND	Power		Power supply ground.
9, 10, 11	Q5, Q6, Q7	Output		LVCMOS/LVTTTL clock outputs. 7 $\Omega$ typical output impedance.
12	CLK	Input	Pulldown	LVCMOS/LVTTTL clock input / 5V tolerant.
13	$V_{DD}$	Power		Core supply pin.
14, 15, 16	Q8, Q9, Q10	Output		LVCMOS/LVTTTL clock outputs. 7 $\Omega$ typical output impedance.
20, 21	Q11, Q12	Output		LVCMOS/LVTTTL clock outputs. 7 $\Omega$ typical output impedance.
22, 23, 24	$V_{DD2}$	Power		Q8 thru Q15 output supply pins.
25, 26, 27	Q13, Q14, Q15	Output		LVCMOS/LVTTTL clock outputs. 7 $\Omega$ typical output impedance.
28	OE2	Input	Pullup	Output enable. When low forces outputs Q8 thru Q15 to HiZ state. 5V tolerant. LVCMOS/LVTTTL interface levels.
29	OE1	Input	Pullup	Output enable. When low forces outputs Q0 thru Q7 to HiZ state. 5V tolerant. LVCMOS/LVTTTL interface levels.
30, 31, 32	Q0, Q1, Q2	Output		LVCMOS/LVTTTL clock outputs. 7 $\Omega$ typical output impedance.

NOTE: *Pullup* and *Pulldown* refer to internal input resistors. See Table 2, Pin characteristics, for typical values.

**TABLE 2. PIN CHARACTERISTICS**

Symbol	Parameter	Test Conditions	Minimum	Typical	Maximum	Units
$C_{IN}$	Input Capacitance			4		pF
$C_{PD}$	Power Dissipation Capacitance (per output)	$V_{DD}, V_{DD1}, V_{DD2} = 3.465V$		11		pF
		$V_{DD1}, V_{DD2} = 2.63V$		9		pF
$R_{PULLUP}$	Input Pullup Resistor			51		K $\Omega$
$R_{PULLDOWN}$	Input Pulldown Resistor			51		K $\Omega$
$R_{OUT}$	Output Impedance	$V_{DD}, V_{DD1}, V_{DD2} = 3.3V$	5	7	12	$\Omega$

**TABLE 3. FUNCTION TABLE**

Inputs		Outputs	
OE1	OE2	Q0:Q7	Q8:Q15
0	0	HiZ	HiZ
1	0	Active	HiZ
0	1	HiZ	Active
1	1	Active	Active

NOTE: OE1 and OE2 are 5V tolerant.



**ABSOLUTE MAXIMUM RATINGS**

Supply Voltage, $V_{DD}$	4.6V
Inputs, $V_i$	-0.5V to $V_{DD} + 0.5V$
Outputs, $V_o$	-0.5V to $V_{DDx} + 0.5V$
Package Thermal Impedance, $\theta_{JA}$	47.9°C/W (0 lfm)
Storage Temperature, $T_{STG}$	-65°C to 150°C

NOTE: Stresses beyond those listed under Absolute Maximum Ratings may cause permanent damage to the device. These ratings are stress specifications only. Functional operation of product at these conditions or any conditions beyond those listed in the *DC Characteristics* or *AC Characteristics* is not implied. Exposure to absolute maximum rating conditions for extended periods may affect product reliability.

www.DataSheet4U.com

**TABLE 4A. POWER SUPPLY DC CHARACTERISTICS,  $V_{DD} = 3.3V \pm 5\%$ ,  $V_{DD1} = V_{DD2} = 3.3V \pm 5\%$  OR  $2.5V \pm 5\%$ ,  $T_A = 0^\circ$  TO  $70^\circ C$**

Symbol	Parameter	Test Conditions	Minimum	Typical	Maximum	Units
$V_{DD}$	Core Supply Voltage		3.135	3.3	3.465	V
$V_{DDx}$	Output Supply Voltage; NOTE 1		3.135	3.3	3.465	V
			2.375	2.5	2.625	V
$I_{DD}$	Power Supply Current				35	mA
$I_{DDx}$	Output Supply Current; NOTE 2				14	mA

NOTE 1:  $V_{DDx}$  denotes  $V_{DD1}$  and  $V_{DD2}$ .

NOTE 2:  $I_{DDx}$  denotes the sum of  $I_{DD1}$  and  $I_{DD2}$ .

**TABLE 4B. POWER SUPPLY DC CHARACTERISTICS,  $V_{DD} = V_{DD1} = V_{DD2} = 2.5V \pm 5\%$ ,  $T_A = 0^\circ$  TO  $70^\circ C$**

Symbol	Parameter	Test Conditions	Minimum	Typical	Maximum	Units
$V_{DD}$	Core Supply Voltage		2.375	2.5	2.625	V
$V_{DDx}$	Output Supply Voltage; NOTE 1		2.375	2.5	2.625	V
$I_{DD}$	Power Supply Current				34	mA
$I_{DDx}$	Output Supply Current; NOTE 2				13	mA

NOTE 1:  $V_{DDx}$  denotes  $V_{DD1}$  and  $V_{DD2}$ .

NOTE 2:  $I_{DDx}$  denotes the sum of  $I_{DD1}$  and  $I_{DD2}$ .



**TABLE 4C. LVCMOS / LVTTTL DC CHARACTERISTICS,  $V_{DD} = V_{DD1} = V_{DD2} = 3.3V \pm 5\%$  OR  $2.5V \pm 5\%$ ;  
 $V_{DD} = 3.3V \pm 5\%$ ,  $V_{DD1} = V_{DD2} = 2.5V \pm 5\%$ ,  $T_A = 0^\circ$  TO  $70^\circ C$**

Symbol	Parameter	Test Conditions	Minimum	Typical	Maximum	Units
$V_{IH}$	Input High Voltage	OE1, OE2	2		$V_{DD} + 0.3$	V
		CLK	2		$V_{DD} + 0.3$	V
$V_{IL}$	Input Low Voltage	OE1, OE2	-0.3		0.8	V
		CLK	-0.3		1.3	V
$I_{IH}$	Input High Current	OE1, OE2	$V_{DD} = V_{IN} = 3.465V$ or $2.625V$		5	$\mu A$
		CLK	$V_{DD} = V_{IN} = 3.465V$ or $2.625V$		150	$\mu A$
$I_{IL}$	Input Low Current	OE1, OE2	$V_{DD} = 3.465V$ or $2.625V$ , $V_{IN} = 0V$	-150		$\mu A$
		CLK	$V_{DD} = 3.465V$ or $2.625V$ , $V_{IN} = 0V$	-5		$\mu A$
$V_{OH}$	Output High Voltage; NOTE 1	$V_{DD1} = V_{DD2} = 3.465V$	2.6			V
		$V_{DD1} = V_{DD2} = 2.625V$	1.8			V
$V_{OL}$	Output Low Voltage; NOTE 1	$V_{DD1} = V_{DD2} = 3.465V$ or $2.625V$			0.5	V
$I_{OZL}$	Output Tristate Current Low				5	$\mu A$
$I_{OZH}$	Output Tristate Current High				5	$\mu A$

NOTE 1: Outputs terminated with  $50\Omega$  to  $V_{DDX}/2$ . See Parameter Measurement Information, "Output Load Test Circuit Diagrams".

**TABLE 5A. AC CHARACTERISTICS,  $V_{DD} = V_{DD1} = V_{DD2} = 3.3V \pm 5\%$ ,  $T_A = 0^\circ$  TO  $70^\circ C$**

Symbol	Parameter	Test Conditions	Minimum	Typical	Maximum	Units
$f_{MAX}$	Output Frequency				200	MHz
$t_{PLH}$	Propagation Delay; NOTE 1	$f \leq 200MHz$	2.0		4.0	ns
$t_{sk(o)}$	Output Skew; NOTE 2, 4	Measured on rising edge @ $V_{DDX}/2$			250	ps
$t_{sk(pp)}$	Part-to-Part Skew; NOTE 3, 4	Measured on rising edge @ $V_{DDX}/2$			700	ps
$t_R / t_F$	Output Rise/Fall Time	20% to 80%	0.4		1.5	ns
odc	Output Duty Cycle	$f \leq 133MHz$	45		55	%
$t_{PW}$	Output Pulse Width	$f > 133MHz$	$t_{PERIOD}/2 - 0.25$	$t_{PERIOD}/2$	$t_{PERIOD}/2 + 0.25$	ns

All parameters measured at  $f_{MAX}$  unless noted otherwise.

NOTE 1: Measured from  $V_{DD}/2$  of the input to  $V_{DDX}/2$  of the output.

NOTE 2: Defined as skew between outputs at the same supply voltage and with equal load conditions. Measured at  $V_{DDX}/2$ .

NOTE 3: Defined as skew between outputs on different devices operating at the same supply voltages and with equal load conditions. Using the same type of inputs on each device, the outputs are measured at  $V_{DDX}/2$ .

NOTE 4: This parameter is defined in accordance with JEDEC Standard 65.





## PARAMETER MEASUREMENT INFORMATION

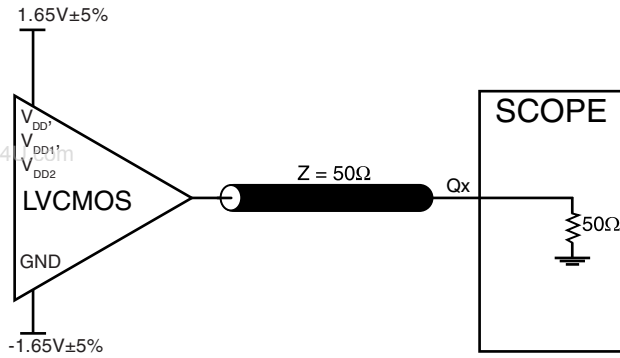

**3.3V CORE/ 3.3V OUTPUT LOAD AC TEST CIRCUIT**

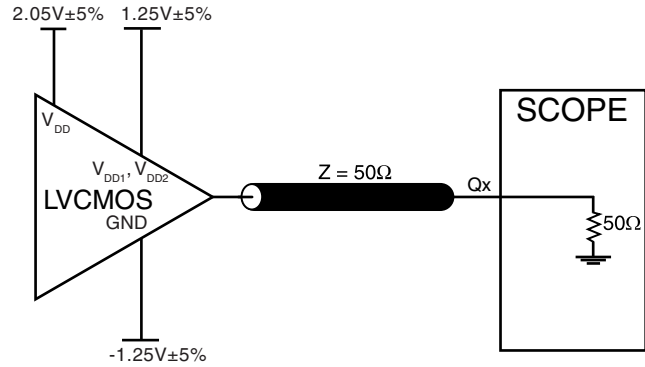

**3.3V CORE/2.5V OUTPUT LOAD AC TEST CIRCUIT**

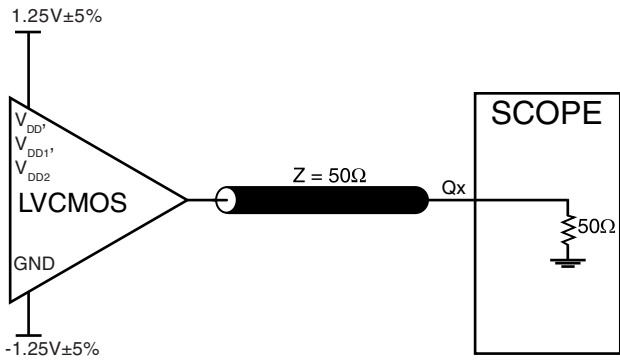

**2.5V CORE/ 2.5V OUTPUT LOAD AC TEST CIRCUIT**

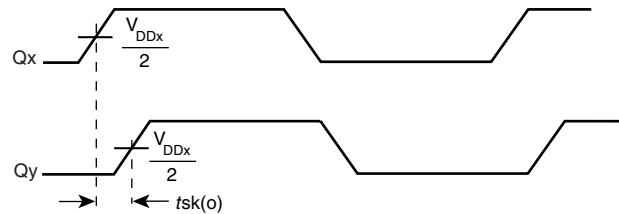

**OUTPUT SKEW**

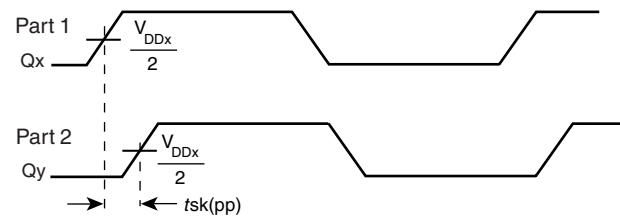

**PART-TO-PART SKEW**

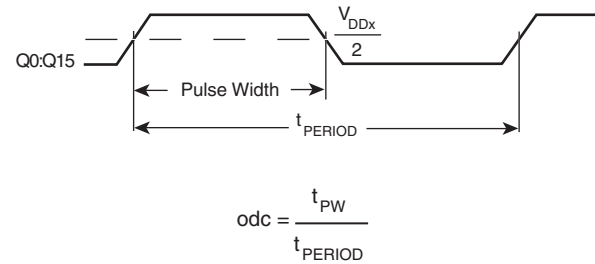

**OUTPUT DUTY CYCLE/PULSE WIDTH/PERIOD**

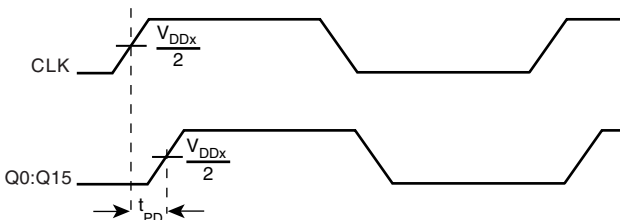

**PROPAGATION DELAY**

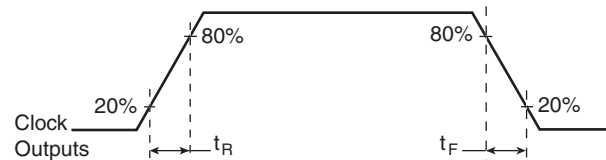

**OUTPUT RISE/FALL TIME**



## RELIABILITY INFORMATION

TABLE 6.  $\theta_{JA}$  VS. AIR FLOW TABLE FOR 32 LEAD LQFP

www.DataSheet4U.com

$\theta_{JA}$ by Velocity (Linear Feet per Minute)			
	0	200	500
Single-Layer PCB, JEDEC Standard Test Boards	67.8°C/W	55.9°C/W	50.1°C/W
Multi-Layer PCB, JEDEC Standard Test Boards	47.9°C/W	42.1°C/W	39.4°C/W

**NOTE:** Most modern PCB designs use multi-layered boards. The data in the second row pertains to most designs.

### TRANSISTOR COUNT

The transistor count for ICS8343-01 is: 985



PACKAGE OUTLINE - Y SUFFIX FOR 32 LEAD LQFP

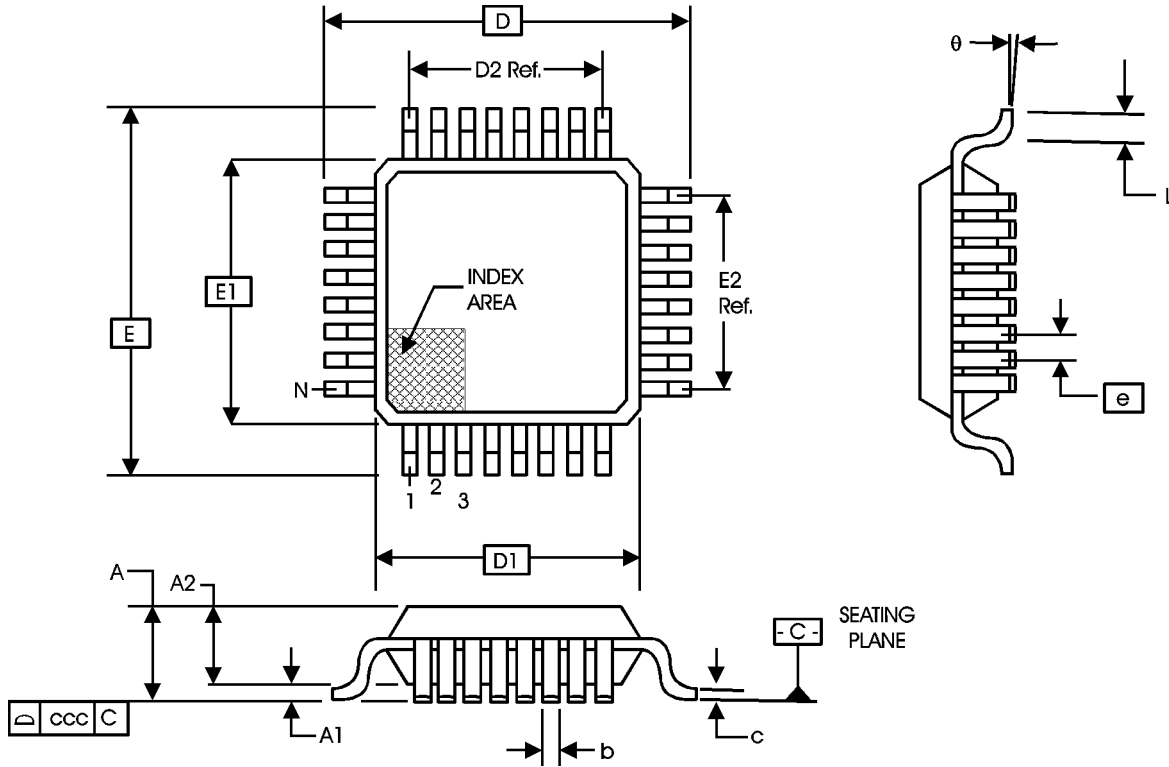

TABLE 7. PACKAGE DIMENSIONS

JEDEC VARIATION ALL DIMENSIONS IN MILLIMETERS			
SYMBOL	BBA		
	MINIMUM	NOMINAL	MAXIMUM
N	32		
A	--	--	1.60
A1	0.05	--	0.15
A2	1.35	1.40	1.45
b	0.30	0.37	0.45
c	0.09	--	0.20
D	9.00 BASIC		
D1	7.00 BASIC		
D2	5.60 Ref.		
E	9.00 BASIC		
E1	7.00 BASIC		
E2	5.60 Ref.		
e	0.80 BASIC		
L	0.45	0.60	0.75
theta	0°	--	7°
ccc	--	--	0.10

Reference Document: JEDEC Publication 95, MS-026





Integrated  
Circuit  
Systems, Inc.

# ICS8343-01

## LOW SKEW, 1-TO-16

### LVC MOS / LVTTTL FANOUT BUFFER

**TABLE 8. ORDERING INFORMATION**

Part/Order Number	Marking	Package	Count	Temperature
ICS8343AY-01	ICS8343AY-01	32 Lead LQFP	250 per tray	0°C to 70°C
ICS8343AY-01T	ICS8343AY-01	32 Lead LQFP on Tape and Reel	1000	0°C to 70°C
ICS8343AY-01LF	ICS8343AY01L	32 Lead "Lead-Free" LQFP	250 per tray	0°C to 70°C
ICS8343AY-01LFT	ICS8343AY01L	32 Lead "Lead-Free" LQFP on Tape and Reel	1000	0°C to 70°C

www.DataSheet4U.com

The aforementioned trademark, HiPerClocks™ and FemtoClocks™ is a trademark of Integrated Circuit Systems, Inc. or its subsidiaries in the United States and/or other countries.

While the information presented herein has been checked for both accuracy and reliability, Integrated Circuit Systems, Incorporated (ICS) assumes no responsibility for either its use or for infringement of any patents or other rights of third parties, which would result from its use. No other circuits, patents, or licenses are implied. This product is intended for use in normal commercial applications. Any other applications such as those requiring extended temperature range, high reliability, or other extraordinary environmental requirements are not recommended without additional processing by ICS. ICS reserves the right to change any circuitry or specifications without notice. ICS does not authorize or warrant any ICS product for use in life support devices or critical medical instruments.



Integrated  
Circuit  
Systems, Inc.

**ICS8343-01**  
LOW SKEW, 1-TO-16  
LVCMOS / LVTTTL FANOUT BUFFER

REVISION HISTORY SHEET				
Rev	Table	Page	Description of Change	Date
A	T2	2	Pin Characteristics Table - changed $C_{IN}$ 4pF max to 4pF typical. Added to $R_{OUT}$ , 5Ω min. and 12Ω max.	9/18/03
	T8	11	Ordering Information correct package column from 48 Lead to 32 Lead.	
B	T5C	5	Added Mixed AC Characteristics Table. Updated format.	8/13/04
B	T8	9	Added Lead-Free marking to Ordering Information Table.	9/16/04

www.DataSheet0.com