

General Description

The ICS840N021I-01 is a LVCMOS/LVTTL clock synthesizer designed for Ethernet applications. The device generates a 125MHz clock signal from a 25MHz crystal with excellent phase jitter performance. The device uses IDT's fourth generation FemtoClock® NG technology for an optimum of high clock frequency, low phase noise performance and low power consumption. The device supports 2.5V or 3.3V voltage supply and is packaged in a small, lead-free (RoHS 6) 8-lead TSSOP package. The extended temperature range supports wireless infrastructure, telecommunication and networking end equipment requirements.

Frequency Table

f_{XTAL} (MHz)	Output Frequency (MHz)
25	125
30.72	153.6

Function Table

Input	Output Enable
OE	
0	Output Q is disabled in high-impedance state
1 (default)	Output Q is enabled.

NOTE: OE is an asynchronous control.

Features

- Fourth generation FemtoClock® NG technology
- 125MHz output clock synthesized from a 25MHz fundamental mode crystal
- One 2.5V or 3.3V LVCMOS/LVTTL clock output
- Crystal interface designed for 25MHz, 12pF parallel resonant crystal
- RMS phase jitter @ 125MHz, using a 25MHz crystal (1.875MHz - 20MHz): 0.151ps (maximum)
- RMS phase jitter @ 125MHz, using a 25MHz crystal (12kHz - 20MHz): 0.478ps (maximum)
- LVCMOS/LVTTL interface level for the output enable input
- Full 2.5V or 3.3V supply voltage
- Available in lead-free (RoHS 6) package
- -40°C to 85°C ambient operating temperature

Block Diagram

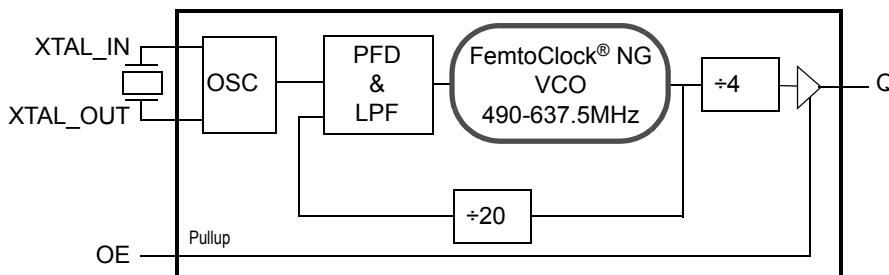

Pin Assignment

VDDA	1	8	VDD
OE	2	7	Q
XTAL_OUT	3	6	GND
XTAL_IN	4	5	DNU

ICS840N021I-01
8-lead TSSOP
4.40mm x 3.0mm x 0.925mm
package body
G Package
Top View

Table 1. Pin Descriptions

Number	Name	Type		Description
1	V _{DDA}	Power		Analog power supply.
2	OE	Input	Pullup	Output enable pin. LVCMOS interface levels.
3, 4	XTAL_OUT, XTAL_IN	Input		Crystal oscillator interface. XTAL_IN is the input, XTAL_OUT is the output.
5	DNU			Do not use.
6	GND	Power		Power supply ground.
7	Q	Output		Single-ended clock output. LVCMOS/LVTTL interface levels.
8	V _{DD}	Power		Core supply pin.

NOTE: *Pullup* refers to an internal input resistor. See Table 2, *Pin Characteristics*, for typical values.

Table 2. Pin Characteristics

Symbol	Parameter	Test Conditions	Minimum	Typical	Maximum	Units
C _{IN}	Input Capacitance			3.5		pF
C _{PD}	Power Dissipation Capacitance	V _{DD} = 3.465V		11		pF
		V _{DD} = 2.625V		9		pF
R _{PULLUP}	Input Pullup Resistor			51		kΩ
R _{OUT}	Output Impedance	V _{DD} = 3.3V		15		Ω
		V _{DD} = 2.5V		19		Ω

Absolute Maximum Ratings

NOTE: Stresses beyond those listed under *Absolute Maximum Ratings* may cause permanent damage to the device. These ratings are stress specifications only. Functional operation of product at these conditions or any conditions beyond those listed in the *DC Characteristics* or *AC Characteristics* is not implied. Exposure to absolute maximum rating conditions for extended periods may affect product reliability.

Item	Rating
Supply Voltage, V_{DD}	3.63V
Inputs, V_I XTAL_IN Other Inputs	0V to 2V -0.5V to $V_{DD} + 0.5V$
Outputs, V_O	-0.5V to $V_{DD} + 0.5V$
Package Thermal Impedance, θ_{JA}	117°C/W (0 mps)
Storage Temperature, T_{STG}	-65°C to 150°C

DC Electrical Characteristics

Table 3A. Power Supply DC Characteristics, $V_{DD} = 3.3V \pm 5\%$ or $2.5V \pm 5\%$, $T_A = -40^\circ\text{C}$ to 85°C

Symbol	Parameter	Test Conditions	Minimum	Typical	Maximum	Units
V_{DD}	Core Supply Voltage		2.375	3.3	3.465	V
V_{DDA}	Analog Supply Voltage		$V_{DD} - 0.18$	3.3	V_{DD}	V
V_{DDA}	Analog Supply Voltage		$V_{DD} - 0.18$	2.5	V_{DD}	V
I_{DDA}	Analog Supply Current				18	mA
I_{DD}	Power Supply Current				67	mA

Table 3B. LVCMOS/LVTTL DC Characteristics, $V_{DD} = 3.3V \pm 5\%$ or $2.5V \pm 5\%$, $T_A = -40^\circ\text{C}$ to 85°C

Symbol	Parameter	Test Conditions	Minimum	Typical	Maximum	Units
V_{IH}	Input High Voltage	$V_{DD} = 3.3V$	2		$V_{DD} + 0.3$	V
		$V_{DD} = 2.5V$	1.7		$V_{DD} + 0.3$	V
V_{IL}	Input Low Voltage	$V_{DD} = 3.3V$	-0.3		0.8	V
		$V_{DD} = 2.5V$	-0.3		0.7	V
I_{IH}	Input High Current	OE $V_{DD} = V_{IN} = 3.465V$ or $2.625V$			5	μA
I_{IL}	Input Low Current	OE $V_{DD} = 3.465V$ or $2.625V$, $V_{IN} = 0V$	-150			μA
V_{OH}	Output High Voltage; NOTE 1	Q $V_{DD} = 3.465V$	2.6			V
		Q $V_{DD} = 2.625V$	1.8			V
V_{OL}	Output Low Voltage; NOTE 1	Q $V_{DD} = 3.465V$ or $2.625V$			0.5	V

NOTE 1: Output terminated with 50Ω to V_{DD} / 2. See Parameter Measurement Information Section, *LVCMOS Output Load Test Circuit Diagrams*.

Table 4. Crystal Characteristics

Parameter	Test Conditions	Minimum	Typical	Maximum	Units
Mode of Oscillation		Fundamental			
Frequency		24.50	25	31.88	MHz
Equivalent Series Resistance (ESR)				80	Ω
Shunt Capacitance				7	pF

AC Characteristics

Table 5. AC Characteristics, $V_{DD} = 3.3V \pm 5\%$ or $2.5V \pm 5\%$, $T_A = -40^\circ\text{C}$ to 85°C

Symbol	Parameter	Test Conditions	Minimum	Typical	Maximum	Units
f_{OUT}	Output Frequency		122.50	125	159.38	MHz
$f_{jit}(\emptyset)$	RMS Phase Jitter (Random); NOTE 1	$f_{OUT} = 125\text{MHz}$, 25MHz Crystal, Integration Range: 1.875MHz – 20MHz		0.099	0.151	ps
		$f_{OUT} = 125\text{MHz}$, 25MHz Crystal, Integration Range: 12kHz – 20MHz		0.288	0.478	ps
Φ_N	Single-Side Band Noise Power	$f_{OUT} = 125\text{MHz}$, Offset: 10Hz		-55.5		dBc/Hz
		$f_{OUT} = 125\text{MHz}$, Offset: 100Hz		-85.9		dBc/Hz
		$f_{OUT} = 125\text{MHz}$, Offset: 1kHz		-115.4		dBc/Hz
		$f_{OUT} = 125\text{MHz}$, Offset: 10kHz		-128.2		dBc/Hz
		$f_{OUT} = 125\text{MHz}$, Offset: 100kHz		-133.2		dBc/Hz
		$f_{OUT} = 125\text{MHz}$, Offset: 1MHz		-143.8		dBc/Hz
		$f_{OUT} = 125\text{MHz}$, Offset: 10MHz		-158.3		dBc/Hz
t_R / t_F	Output Rise/Fall Time	20% to 80%	200		600	ps
odc	Output Duty Cycle		48		52	%

NOTE: Electrical parameters are guaranteed over the specified ambient operating temperature range, which is established when the device is mounted in a test socket with maintained transverse airflow greater than 500 lfm. The device will meet specifications after thermal equilibrium has been reached under these conditions.

NOTE: Characterized with a 25MHz and 30.72MHz crystal.

NOTE 1: Please refer to the phase noise plots.

Typical Phase Noise at 125MHz (1.875MHz-20MHz)

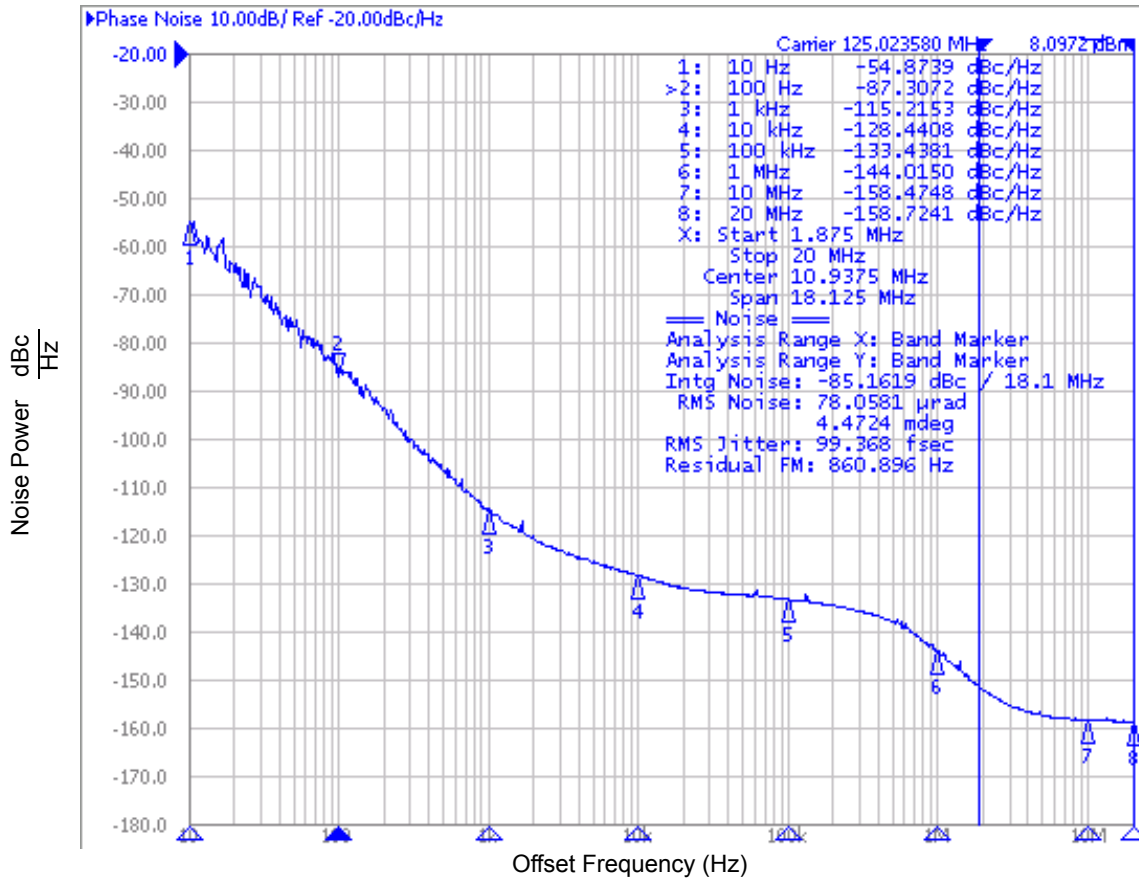

Typical Phase Noise at 125MHz (12kHz-20MHz)

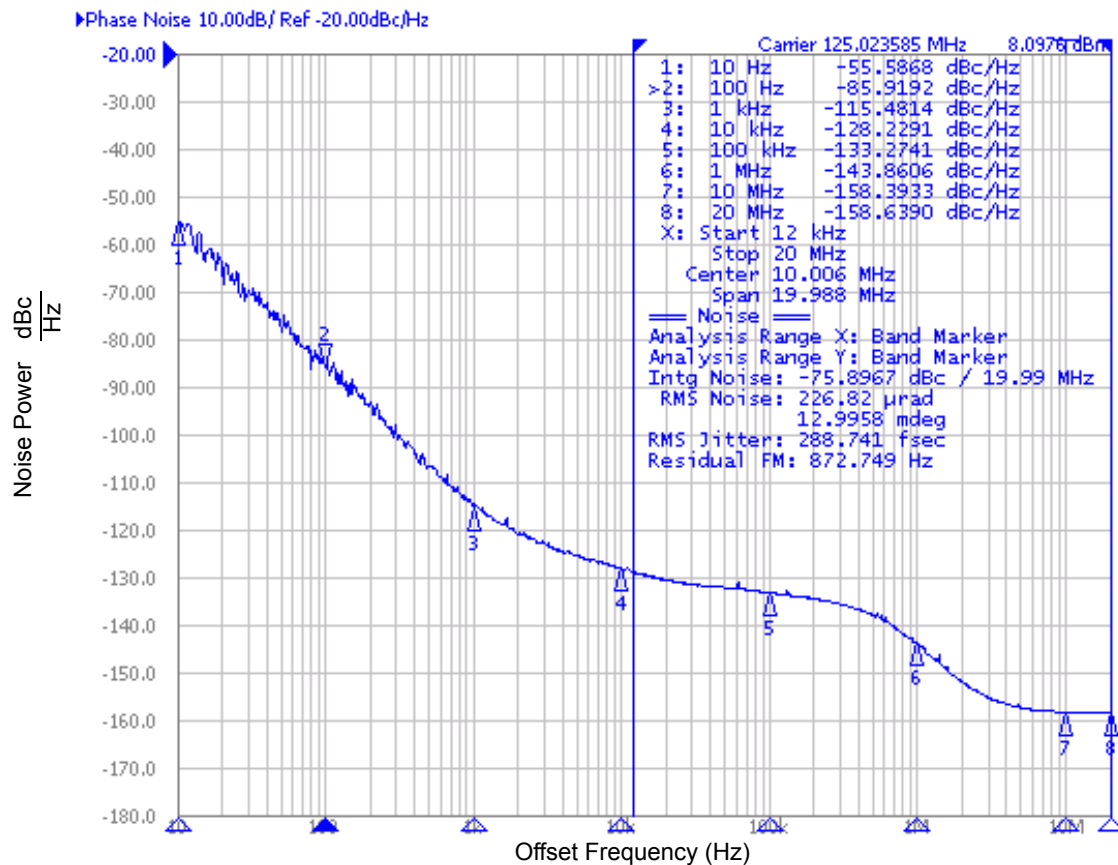

Parameter Measurement Information

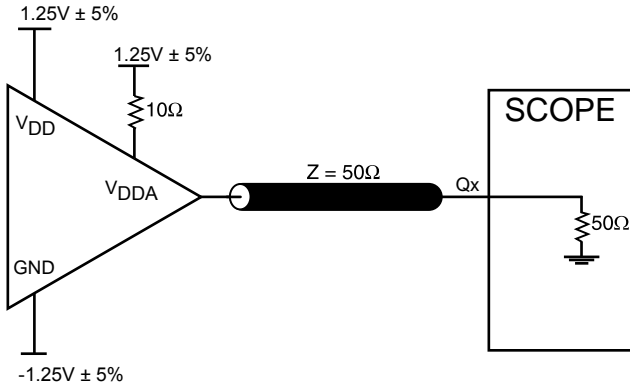

2.5V LVCMOS/LVTTL Output Load AC Test Circuit

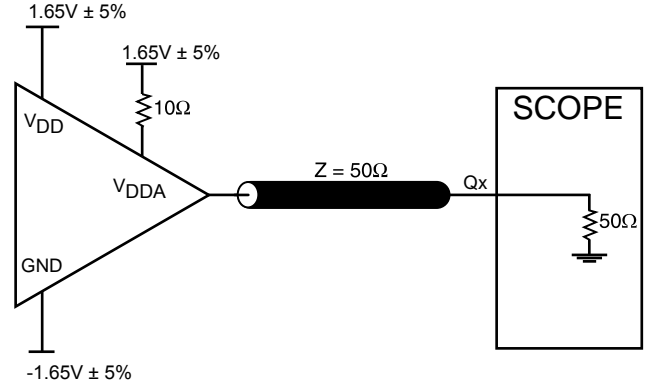

3.3V LVCMOS/LVTTL Output Load AC Test Circuit

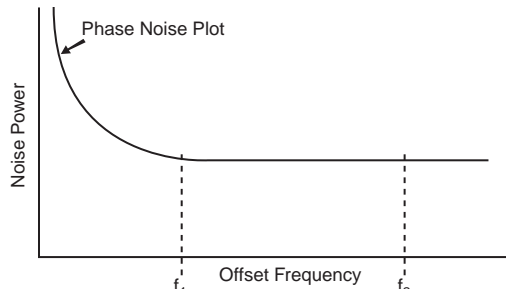

$$\text{RMS Phase Jitter} = \frac{1}{\sqrt{2} * \pi * f} * \sqrt{\text{Area Under Curve Defined by the Offset Frequency Markers}}$$

RMS Phase Jitter

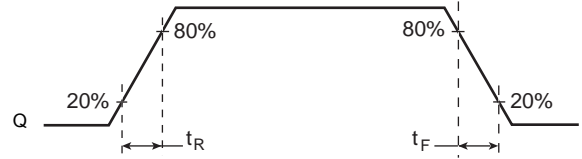

Output Rise/Fall Time

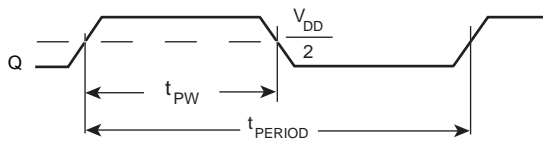

$$\text{odc} = \frac{t_{PW}}{t_{PERIOD}} * 100\%$$

Output Duty Cycle/Pulse Width/Period

Applications Information

Overdriving the XTAL Interface

The XTAL_IN input can be overdriven by an LVCMOS driver or by one side of a differential driver through an AC coupling capacitor. The XTAL_OUT pin can be left floating. The amplitude of the input signal should be between 500mV and 1.8V and the slew rate should not be less than 0.2V/nS. For 3.3V LVCMOS inputs, the amplitude must be reduced from full swing to at least half the swing in order to prevent signal interference with the power rail and to reduce internal noise. *Figure 1A* shows an example of the interface diagram for a high speed 3.3V LVCMOS driver. This configuration requires that the sum of the output impedance of the driver (R_o) and the series resistance (R_s) equals the transmission line impedance. In addition, matched termination at the crystal input will attenuate the signal in half. This

can be done in one of two ways. First, R_1 and R_2 in parallel should equal the transmission line impedance. For most 50Ω applications, R_1 and R_2 can be 100Ω . This can also be accomplished by removing R_1 and changing R_2 to 50Ω . The values of the resistors can be increased to reduce the loading for a slower and weaker LVCMOS driver. *Figure 1B* shows an example of the interface diagram for an LVPECL driver. This is a standard LVPECL termination with one side of the driver feeding the XTAL_IN input. It is recommended that all components in the schematics be placed in the layout. Though some components might not be used, they can be utilized for debugging purposes. The datasheet specifications are characterized and guaranteed by using a quartz crystal as the input.

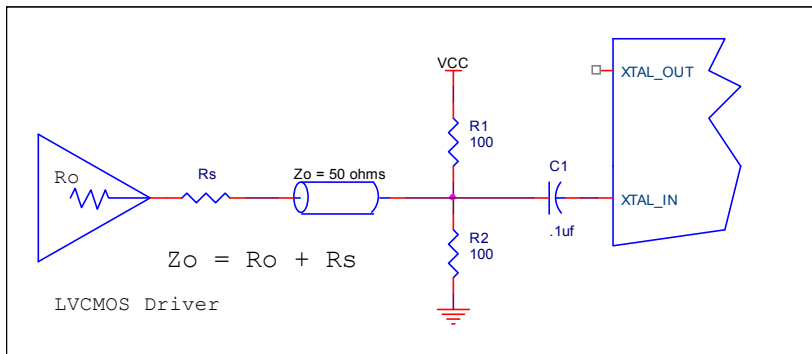

Figure 1A. General Diagram for LVCMOS Driver to XTAL Input Interface

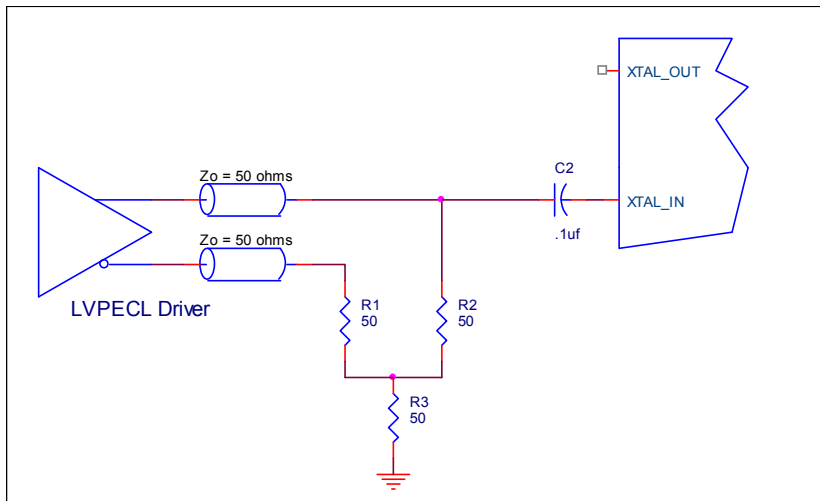

Figure 1B. General Diagram for LVPECL Driver to XTAL Input Interface

Schematic Layout

Figure 2 shows an example ICS840N021I-01 application schematic in which the device is operated at $V_{DD} = V_{DDA} = 3.3V$. The schematic example focuses on functional connections and is intended as an example only and may not represent the exact user configuration. Refer to the pin description and functional tables in the datasheet to ensure the logic control inputs are properly set. For example OE can be configured from an FPGA instead of set with a pullup resistor as shown.

As with any high speed analog circuitry, the power supply pins are vulnerable to random noise, so to achieve optimum jitter performance isolation of the V_{DD} pin from power supply is required. In order to achieve the best possible filtering, it is recommended that the placement of the filter components be on the device side of the

PCB as close to the power pins as possible. If space is limited, the $0.1\mu F$ capacitor on the V_{DD} pin must be placed on the device side with direct return to the ground plane through vias. The remaining filter components can be on the opposite side of the PCB.

Power supply filter recommendations are a general guideline to be used for reducing external noise from coupling into the devices. The filter performance is designed for wide range of noise frequencies. This low-pass filter starts to attenuate noise at approximately 10kHz. If a specific frequency noise component is known, such as switching power supply frequencies, it is recommended that component values be adjusted and if required, additional filtering be added. Additionally, good general design practices for power plane voltage stability suggests adding bulk capacitances in the local area of all devices.

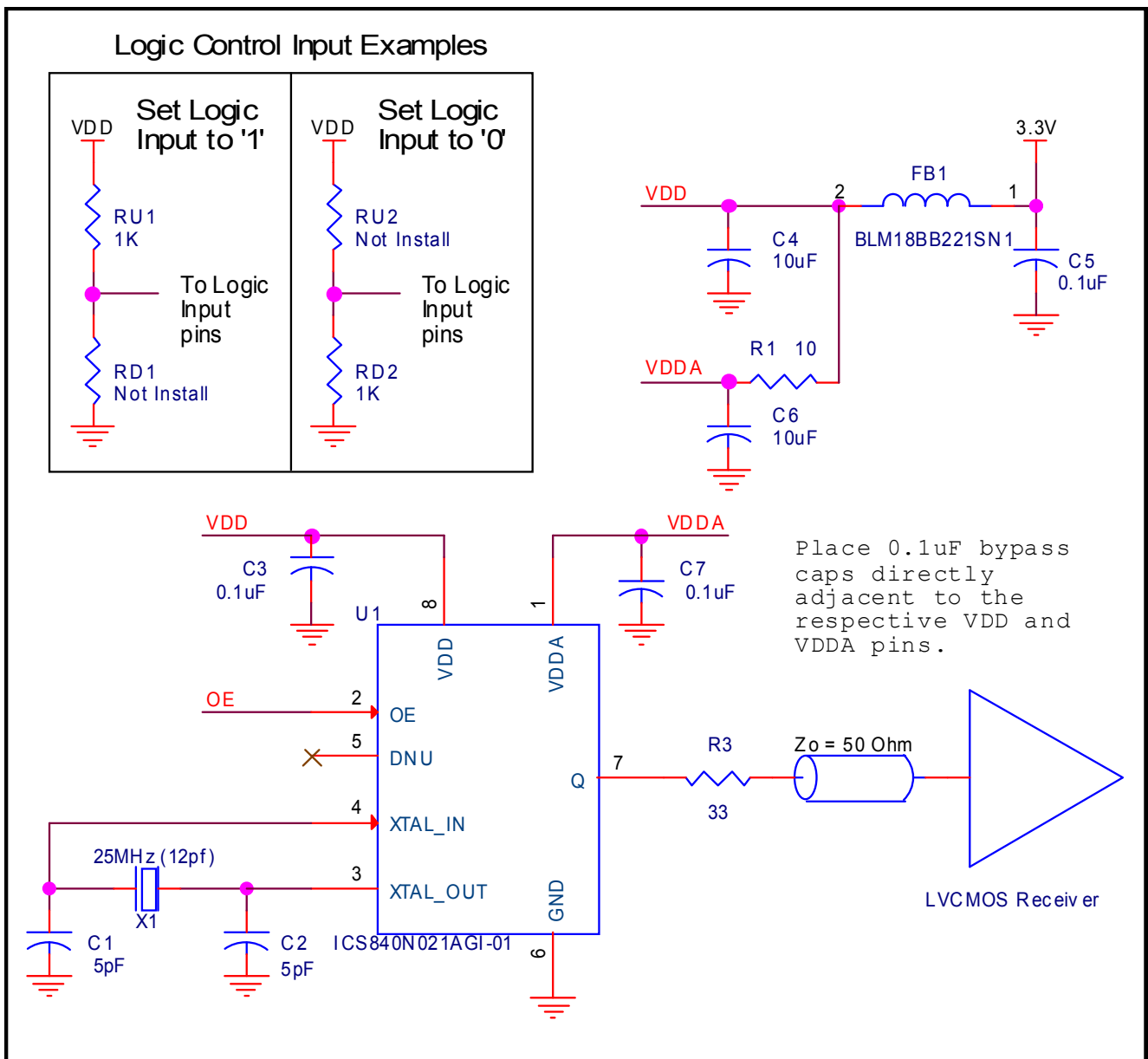

Figure 2. ICS840N021I-01 Application Schematic

Power Considerations

This section provides information on power dissipation and junction temperature for the ICS840N021I-01. Equations and example calculations are also provided.

1. Power Dissipation.

The total power dissipation for the ICS840N021I-01 is the sum of the core power plus the analog power plus the power dissipated in the load(s). The following is the power dissipation for $V_{DD} = 3.3V + 5\% = 3.465V$, which gives worst case results.

- Power (core)_{MAX} = $V_{DD_MAX} * (I_{DD} + I_{DDA}) = 3.465V * (67mA + 18mA) = \mathbf{294.53mW}$
- Output Impedance R_{OUT} Current due to Loading 50Ω to $V_{DD}/2$
Output Current $I_{OUT} = V_{DD_MAX} / [2 * (50\Omega + R_{OUT})] = 3.465V / [2 * (50\Omega + 15\Omega)] = \mathbf{26.7mA}$
- Power Dissipation on the R_{OUT} per LVCMOS output
Power (R_{OUT}) = $R_{OUT} * (I_{OUT})^2 = 15\Omega * (26.7mA)^2 = \mathbf{10.7mW}$
- Total Power (R_{OUT}) = $10.7mW * 1 = \mathbf{10.7mW}$

Dynamic Power Dissipation at 153.6MHz

$$\text{Power (153.6MHz)} = C_{PD} * \text{Frequency} * (V_{DD})^2 = 11pF * 153.6MHz * (3.465V)^2 = \mathbf{20.29mW}$$

$$\text{Total Power (153.6MHz)} = 20.29mW * 1 = \mathbf{20.29mW}$$

Total Power Dissipation

- Total Power

$$= \text{Power (core)}_{MAX} + \text{Power (R}_{OUT}) + \text{Power (153.6MHz)}$$

$$= 294.53mW + 10.7mW + 20.29mW$$

$$= \mathbf{325.52mW}$$

2. Junction Temperature.

Junction temperature, T_j , is the temperature at the junction of the bond wire and bond pad directly affects the reliability of the device. The maximum recommended junction temperature is 125°C . Limiting the internal transistor junction temperature, T_j , to 125°C ensures that the bond wire and bond pad temperature remains below 125°C .

The equation for T_j is as follows: $T_j = \theta_{JA} * Pd_total + T_A$

T_j = Junction Temperature

θ_{JA} = Junction-to-Ambient Thermal Resistance

Pd_total = Total Device Power Dissipation (example calculation is in section 1 above)

T_A = Ambient Temperature

In order to calculate junction temperature, the appropriate junction-to-ambient thermal resistance θ_{JA} must be used. Assuming no air flow and a multi-layer board, the appropriate value is 117°C/W per Table 6 below.

Therefore, T_j for an ambient temperature of 85°C with all outputs switching is:

$$85^\circ\text{C} + 0.326W * 117^\circ\text{C/W} = 123.2^\circ\text{C}. \text{ This is below the limit of } 125^\circ\text{C}.$$

This calculation is only an example. T_j will obviously vary depending on the number of loaded outputs, supply voltage, air flow and the type of board (multi-layer).

Table 6. Thermal Resistance θ_{JA} for 8 Lead TSSOP, Forced Convection

θ_{JA} by Velocity	
Meters per Second	0
Multi-Layer PCB, JEDEC Standard Test Boards	117°C/W

Reliability Information

Table 7. θ_{JA} vs. Air Flow Table for a 8-lead TSSOP

θ_{JA} vs. Air Flow	
Meters per Second	0
Multi-Layer PCB, JEDEC Standard Test Boards	117°C/W

Transistor Count

The transistor count for ICS840N021I-01 is: 24,811

Package Outline and Package Dimensions

Package Outline - G Suffix for 8 Lead TSSOP

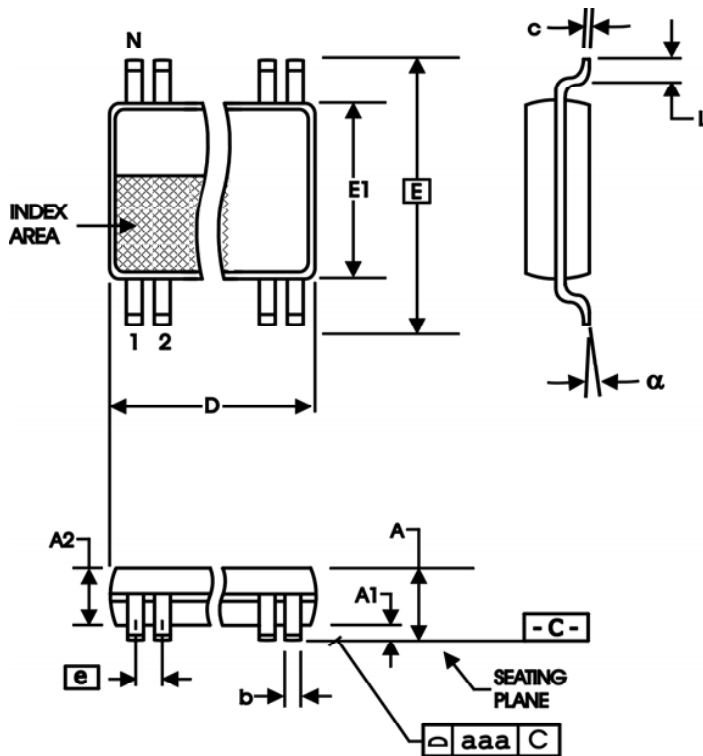

Table 8. Package Dimensions

All Dimensions in Millimeters		
Symbol	Minimum	Maximum
N	8	
A		1.20
A1	0.5	0.15
A2	0.80	1.05
b	0.19	0.30
c	0.09	0.20
D	2.90	3.10
E	6.40 Basic	
E1	4.30	4.50
e	0.65 Basic	
L	0.45	0.75
α	0°	8°
aaa		0.10

Reference Document: JEDEC Publication 95, MO-153

Table 9. Ordering Information

Part/Order Number	Marking	Package	Shipping Packaging	Temperature
840N021BGI-01LF	2BI1L	Lead-Free, 8-lead TSSOP	Tube	-40°C to 85°C
840N021BGI-01LFT	2BI1L	Lead-Free, 8-lead TSSOP	Tape & Reel	-40°C to 85°C

NOTE: Parts that are ordered with an "LF" suffix to the part number are the Pb-Free configuration and are RoHS compliant

IMPORTANT NOTICE AND DISCLAIMER

RENESAS ELECTRONICS CORPORATION AND ITS SUBSIDIARIES (“RENESAS”) PROVIDES TECHNICAL SPECIFICATIONS AND RELIABILITY DATA (INCLUDING DATASHEETS), DESIGN RESOURCES (INCLUDING REFERENCE DESIGNS), APPLICATION OR OTHER DESIGN ADVICE, WEB TOOLS, SAFETY INFORMATION, AND OTHER RESOURCES “AS IS” AND WITH ALL FAULTS, AND DISCLAIMS ALL WARRANTIES, EXPRESS OR IMPLIED, INCLUDING, WITHOUT LIMITATION, ANY IMPLIED WARRANTIES OF MERCHANTABILITY, FITNESS FOR A PARTICULAR PURPOSE, OR NON-INFRINGEMENT OF THIRD PARTY INTELLECTUAL PROPERTY RIGHTS.

These resources are intended for developers skilled in the art designing with Renesas products. You are solely responsible for (1) selecting the appropriate products for your application, (2) designing, validating, and testing your application, and (3) ensuring your application meets applicable standards, and any other safety, security, or other requirements. These resources are subject to change without notice. Renesas grants you permission to use these resources only for development of an application that uses Renesas products. Other reproduction or use of these resources is strictly prohibited. No license is granted to any other Renesas intellectual property or to any third party intellectual property. Renesas disclaims responsibility for, and you will fully indemnify Renesas and its representatives against, any claims, damages, costs, losses, or liabilities arising out of your use of these resources. Renesas' products are provided only subject to Renesas' Terms and Conditions of Sale or other applicable terms agreed to in writing. No use of any Renesas resources expands or otherwise alters any applicable warranties or warranty disclaimers for these products.

(Rev.1.0 Mar 2020)

Corporate Headquarters

TOYOSU FORESIA, 3-2-24 Toyosu,
Koto-ku, Tokyo 135-0061, Japan
www.renesas.com

Contact Information

For further information on a product, technology, the most up-to-date version of a document, or your nearest sales office, please visit:
www.renesas.com/contact/

Trademarks

Renesas and the Renesas logo are trademarks of Renesas Electronics Corporation. All trademarks and registered trademarks are the property of their respective owners.