



Integrated
Circuit
Systems, Inc.

PRELIMINARY

ICS843001I-23
FEMTOCLOCKS™ CRYSTAL-TO-3.3V LVPECL/LVCMOS
FREQUENCY SYNTHESIZER

GENERAL DESCRIPTION



The ICS843001I-23 is a highly versatile, low phase noise LVPECL/LVCMOS Synthesizer which can generate low jitter reference clocks for a variety of communication applications and is a member of the HiPerClocks™ family of high performance clock solutions from ICS.

The dual crystal interface allows the synthesizer to support up to three communication standards in a given application (i.e. SONET with a 19.44MHz crystal, 1Gb/10Gb Ethernet and Fibre Channel using a 25MHz crystal). The rms phase jitter performance is typically less than 1ps, thus making the device acceptable for use in demanding applications such as OC48 SONET, GbE/10Gb Ethernet and SAN applications. The ICS843001I-23 is packaged in a small 24-pin TSSOP package.

FEATURES

- One 3.3V LVPECL output pair and one LVCMOS/LVTTL REF_OUT output
- Selectable crystal oscillator interfaces or LVCMOS/LVTTL single-ended input
- Crystal and CLK range: 17.5MHz - 29.54MHz
- Able to generate GbE/10GbE/12GbE, Fibre Channel (1Gb/4Gb/10Gb), PCI-E and SATA from a 25MHz crystal
- VCO range: 1.12GHz - 1.3GHz
- Supports the following applications: SONET, Ethernet, Fibre Channel, Serial ATA, and HDTV
- RMS phase jitter @ 622.08MHz (12kHz - 20MHz): <1ps (typical) design target
- Supply modes:
 V_{CC}/V_{CCO}
 3.3V/3.3V
 3.3V/2.5V
 2.5V/2.5V
- -40°C to 85°C ambient operating temperature
- Available in both standard and lead-free RoHS-compliant packages

BLOCK DIAGRAM

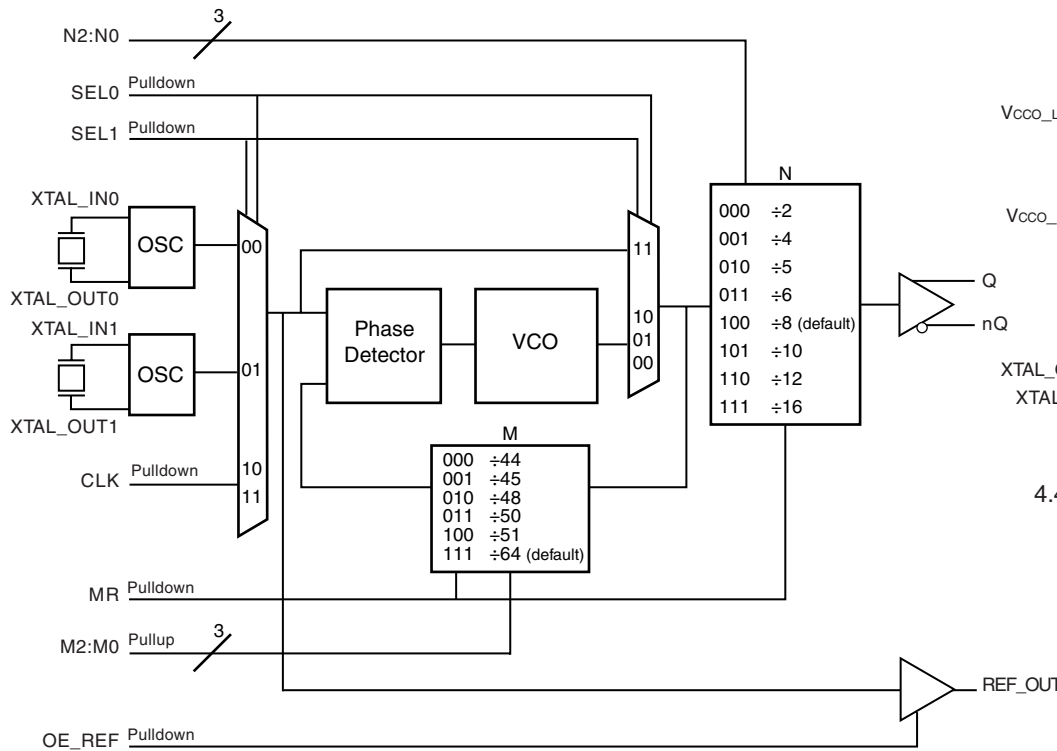

PIN ASSIGNMENT

VCCO_LVCMOS	1	24	REF_OUT
N0	2	23	VEE
N1	3	22	OE_REF
N2	4	21	M2
VCCO_LVPECL	5	20	M1
Q	6	19	M0
nQ	7	18	MR
VEE	8	17	SEL1
VCCA	9	16	SEL0
VCC	10	15	CLK
XTAL_OUT1	11	14	XTAL_IN0
XTAL_IN1	12	13	XTAL_OUT0

ICS843001I-23

24-Lead TSSOP

4.40mm x 7.8mm x 0.92mm

package body

G Package

Top View

The Preliminary Information presented herein represents a product in prototyping or pre-production. The noted characteristics are based on initial product characterization. Integrated Circuit Systems, Incorporated (ICS) reserves the right to change any circuitry or specifications without notice.



TABLE 1. PIN DESCRIPTIONS

Number	Name	Type		Description
1	V _{CCO_CMOS}	Power		Output supply pin for LVCMOS/LVTTL REF_OUT output.
2, 3	N0, N1	Input	Pulldown	Output divider select pins. See Table 3C. LVCMOS/LVTTL interface levels.
4	N2	Input	Pullup	
5	V _{CCO_LVPECL}	Power		Output supply pin for LVPECL output.
6, 7	Q, nQ	Output		Differential output pair. LVPECL interface levels.
8, 23	V _{EE}	Power		Negative supply pin.
9	V _{CCA}	Power		Analog supply pin.
10	V _{CC}	Power		Core supply pin.
11 12	XTAL_OUT1, XTAL_IN1	Input		Parallel resonant crystal interface. XTAL_OUT1 is the output, XTAL_IN1 is the input.
13 14	XTAL_OUT0, XTAL_IN0	Input		Parallel resonant crystal interface. XTAL_OUT0 is the output, XTAL_IN0 is the input.
15	CLK	Input	Pulldown	LVCMOS/LVTTL clock input.
16, 17	SEL0, SEL1	Input	Pulldown	Input MUX select pins. LVCMOS/LVTTL interface levels.
18	MR	Input	Pulldown	Active HIGH Master Reset. When logic HIGH, the internal dividers are reset causing the true output Q to go low and the inverted output nQ to go high. When logic LOW, the internal dividers and the outputs are enabled. LVCMOS/LVTTL interface levels.
19, 20, 21	M0, M1, M2	Input	Pullup	Feedback divider select pins. See Table 3B. LVCMOS/LVTTL interface levels.
22	OE_REF	Input	Pulldown	Reference clock output enable. Default Low. See Table 3E. LVCMOS/LVTTL interface levels.
24	REF_OUT	Output		Reference clock output. LVCMOS/LVTTL interface levels.

NOTE: Pullup and Pulldown refer to internal input resistors. See Table 2, Pin Characteristics, for typical values.

TABLE 2. PIN CHARACTERISTICS

Symbol	Parameter	Test Conditions	Minimum	Typical	Maximum	Units
C _{IN}	Input Capacitance			4		pF
R _{PULLDOWN}	Input Pulldown Resistor			51		kΩ
R _{PULLUP}	Input Pullup Resistor			51		kΩ
R _{out}	Output Impedance	REF_OUT	5	7	12	Ω



Integrated
Circuit
Systems, Inc.

PRELIMINARY

ICS843001I-23
FEMTOCLOCKS™ CRYSTAL-TO-3.3V LVPECL/LVCMOS
FREQUENCY SYNTHESIZER

TABLE 3A. COMMON CONFIGURATIONS TABLE

Input XTAL Input (MHz)	Feedback Divider	VCO (MHz)	N Divider Value	Output Frequency (MHz)	Application
27	44	1188	16	74.25	HDTV
24.75	48	1188	16	74.25	HDTV
19.44	64	1244.16	8	155.52	SONET
19.44	64	1244.16	2	622.08	SONET
19.44	64	1244.16	4	311.04	SONET
25	50	1250	10	125	GigE
25	50	1250	8	156.25	10 GigE
25	50	1250	5	250	GigE
25	50	1250	4	312.5	XGMII
25	50	1250	2	625	10 GigE
25	45	1125	6	187.5	12 GigE
25	48	1200	12	100	PCI Express
25	48	1200	8	150	SATA
25	48	1200	16	75	SATA
25	51	1275	12	106.25	Fibre Channel
25	51	1275	8	159.375	10 Gig Fibre Channel
25	51	1275	6	212.5	4 Gig Fibre Channel

**TABLE 3B. PROGRAMMABLE M OUTPUT DIVIDER
FUNCTION TABLE**

Inputs			M Divider Value	Input Frequency	
M2	M1	M0		Minimum	Maximum
0	0	0	44	25.5	29.54
0	0	1	45	24.9	28.88
0	1	0	48	23.3	27.08
0	1	1	50	22.4	26.0
1	0	0	51	22.0	25.49
1	1	1	64 (default)	17.5	20.31

**TABLE 3C. PROGRAMMABLE N OUTPUT DIVIDER
FUNCTION TABLE**

Inputs			N Divide Value
N2	N1	N0	
0	0	0	2
0	0	1	4
0	1	0	5
0	1	1	6
1	0	0	8 (default)
1	0	1	10
1	1	0	12
1	1	1	16

TABLE 3D. BYPASS MODE FUNCTION TABLE

Inputs		Reference Input	PLL Mode
SEL1	SEL0		
0	0	XTAL0	Active
0	1	XTAL1	Active
1	0	CLK	Active
1	1	CLK	Bypass

TABLE 3E. OE_REF OUTPUT FUNCTION TABLE

Inputs	Output
OE_REF	REF_OUT
0	Hi-Z
1	Active



ABSOLUTE MAXIMUM RATINGS

Supply Voltage, V_{CC}	4.6V
Inputs, V_i	-0.5V to $V_{CC} + 0.5V$
Outputs, I_o (LVPECL)	
Continuous Current	50mA
Surge Current	100mA
Outputs, V_o (LVCMOS)	-0.5V to $V_{CCO} + 0.5V$
Package Thermal Impedance, θ_{JA}	70°C/W (0 mps)
Storage Temperature, T_{STG}	-65°C to 150°C

NOTE: Stresses beyond those listed under Absolute Maximum Ratings may cause permanent damage to the device. These ratings are stress specifications only. Functional operation of product at these conditions or any conditions beyond those listed in the *DC Characteristics* or *AC Characteristics* is not implied. Exposure to absolute maximum rating conditions for extended periods may affect product reliability.

www.DataSheet4U.com

TABLE 4A. POWER SUPPLY DC CHARACTERISTICS, $V_{CC} = V_{CCA} = V_{CCO_LVPECL} = V_{CCO_LVCMOS} = 3.3V \pm 5\%$, $T_A = -40^\circ C$ TO $85^\circ C$

Symbol	Parameter	Test Conditions	Minimum	Typical	Maximum	Units
V_{CC}	Core Supply Voltage		3.135	3.3	3.465	V
V_{CCA}	Analog Supply Voltage		3.135	3.3	3.465	V
V_{CCO_LVPECL}	Output Supply Voltage		3.135	3.3	3.465	V
V_{CCO_LVCMOS}	Output Supply Voltage		3.135	3.3	3.465	V
I_{EE}	Power Supply Current	OE_REF = 0		TBD		mA
		OE_REF = 1, REF_OUT = 29.54MHz		TBD		mA
I_{CCA}	Analog Supply Current			5		mA
I_{CCO_LVPECL}	Output Supply Current	OE_REF = 0		TBD		mA
I_{CCO_LVCMOS}	Output Supply Current	OE_REF = 1, REF_OUT = 29.54MHz		TBD		mA

TABLE 4B. POWER SUPPLY DC CHARACTERISTICS, $V_{CC} = V_{CCA} = 3.3V \pm 5\%$, $V_{CCO_LVPECL} = V_{CCO_LVCMOS} = 2.5V \pm 5\%$, $T_A = -40^\circ C$ TO $85^\circ C$

Symbol	Parameter	Test Conditions	Minimum	Typical	Maximum	Units
V_{CC}	Core Supply Voltage		3.135	3.3	3.465	V
V_{CCA}	Analog Supply Voltage		3.135	3.3	3.465	V
V_{CCO_LVPECL}	Output Supply Voltage		2.625	2.5	2.625	V
V_{CCO_LVCMOS}	Output Supply Voltage		2.625	2.5	2.625	V
I_{EE}	Power Supply Current	OE_REF = 0		TBD		mA
		OE_REF = 1, REF_OUT = 29.54MHz		TBD		mA
I_{CCA}	Analog Supply Current			TBD		mA
I_{CCO_LVPECL}	Output Supply Current	OE_REF = 0		TBD		mA
I_{CCO_LVCMOS}	Output Supply Current	OE_REF = 1, REF_OUT = 29.54MHz		TBD		mA



Integrated
Circuit
Systems, Inc.

PRELIMINARY

ICS843001I-23
FEMTOCLOCKS™ CRYSTAL-TO-3.3V LVPECL/LVCMOS
FREQUENCY SYNTHESIZER

TABLE 4C. POWER SUPPLY DC CHARACTERISTICS, $V_{CC} = V_{CCA} = V_{CCO_LVPECL}, V_{CCO_LVCMOS} = 2.5V \pm 5\%$, $T_A = -40^\circ C$ TO $85^\circ C$

Symbol	Parameter	Test Conditions	Minimum	Typical	Maximum	Units
V_{CC}	Core Supply Voltage		2.625	2.5	2.625	V
V_{CCA}	Analog Supply Voltage		2.625	2.5	2.625	V
V_{CCO_LVPECL}	Output Supply Voltage		2.625	2.5	2.625	V
V_{CCO_LVCMOS}	Output Supply Voltage		2.625	2.5	2.625	V
I_{EE}	Power Supply Current	OE_REF = 0		TBD		mA
		OE_REF = 1, REF_OUT = 29.54MHz		TBD		mA
I_{CCA}	Analog Supply Current			5		mA
I_{CCO_LVPECL}	Output Supply Current	OE_REF = 0		TBD		mA
I_{CCO_LVCMOS}	Output Supply Current	OE_REF = 1, REF_OUT = 29.54MHz		TBD		mA

TABLE 4D. LVCMOS / LVTTTL DC CHARACTERISTICS, $V_{CC} = V_{CCA} = V_{CCO_LVCMOS} = 3.3V \pm 5\%$ OR $2.5V \pm 5\%$, OR $V_{CC} = V_{CCA} = 3.3V \pm 5\%$, $V_{CCO_LVCMOS} = 2.5V \pm 5\%$, $T_A = -40^\circ C$ TO $85^\circ C$

Symbol	Parameter	Test Conditions	Minimum	Typical	Maximum	Units
V_{IH}	Input High Voltage	$V_{CC} = 3.3V$	2		$V_{CC} + 0.3$	V
		$V_{CC} = 2.5V$	1.7		$V_{CC} + 0.3$	V
V_{IL}	Input Low Voltage	$V_{CC} = 3.3V$	-0.3		0.8	V
		$V_{CC} = 2.5V$	-0.3		0.7	V
I_{IH}	Input High Current	CLK, SEL0, SEL1, OE_REF, MR, N0, N1 $V_{CC} = V_{IN} = 3.465V$ or 2.625V			150	μA
		N2, M0:M2 $V_{CC} = V_{IN} = 3.465V$ or 2.625V			5	μA
I_{IL}	Input Low Current	CLK, SEL0, SEL1, OE_REF, MR, N0, N1 $V_{CC} = 3.465V$ or 2.625V, $V_{IN} = 0V$	-5			μA
		N2, M0:M2 $V_{CC} = 3.465V$ or 2.625V, $V_{IN} = 0V$	-150			μA
V_{OH}	Output High Voltage; NOTE 1	REF_OUT $V_{CCO_LVCMOS} = 3.465V$	2.6			V
		REF_OUT $V_{CCO_LVCMOS} = 2.625V$	1.8			V
V_{OL}	Output Low Voltage; NOTE 1	REF_OUT $V_{CCO_LVCMOS} = 3.465V$ or 2.625V			0.5	V
$\Delta V/\Delta T$	Input Edge Rate	CLK	20% - 80%		TBD	V/ns

NOTE 1: Output terminated with 50Ω to $V_{CCO_LVCMOS}/2$. See Parameter Measurement Information Section, "Output Load Test Circuit Diagram" diagrams.

TABLE 4E. LVPECL DC CHARACTERISTICS, $V_{CC} = V_{CCA} = V_{CCO_LVPECL} = 3.3V \pm 5\%$ OR $2.5V \pm 5\%$, OR

$V_{CC} = V_{CCA} = 3.3V \pm 5\%$, $V_{CCO_LVPECL} = 2.5V \pm 5\%$, $T_A = -40^\circ C$ TO $85^\circ C$

Symbol	Parameter	Test Conditions	Minimum	Typical	Maximum	Units
V_{OH}	Output High Voltage; NOTE 1		$V_{CCO_LVPECL} - 1.4$		$V_{CCO_LVPECL} - 0.9$	V
V_{OL}	Output Low Voltage; NOTE 1		$V_{CCO_LVPECL} - 2.0$		$V_{CCO_LVPECL} - 1.7$	V
V_{SWING}	Peak-to-Peak Output Voltage Swing		0.6		1.0	V

NOTE 1: Outputs terminated with 50Ω to $V_{CCO_LVPECL} - 2V$.



Integrated
Circuit
Systems, Inc.

PRELIMINARY

ICS843001I-23
FEMTOCLOCKS™ CRYSTAL-TO-3.3V LVPECL/LVCMOS
FREQUENCY SYNTHESIZER

TABLE 5. CRYSTAL CHARACTERISTICS

Parameter	Test Conditions	Minimum	Typical	Maximum	Units
Mode of Oscillation		Fundamental			MHz
Frequency		17.5		29.54	MHz
Equivalent Series Resistance (ESR)				50	Ω
Shunt Capacitance				7	pF
Drive Level				1	mW

NOTE: Characterized using an 18pF parallel resonant crystal.

www.DataSheet4U.com

TABLE 6A. AC CHARACTERISTICS, $V_{CC} = V_{CCA} = V_{CCO_LVPECL}, V_{CCO_LVCMOS} = 3.3V \pm 5\%$, $T_A = -40^\circ C$ to $85^\circ C$

Symbol	Parameter	Test Conditions	Minimum	Typical	Maximum	Units
f_{OUT}	Output Frequency		56		650	MHz
t_{PD}	Propagation Delay, NOTE 1	CLK to REF_OUT		TBD		ns
$f_{jit}(\emptyset)$	RMS Phase Jitter, (Random); NOTE 2, 3	622.08MHz (12kHz - 20MHz)		TBD		ps
f_{VCO}	PLL VCO Lock Range		1.12		1.3	GHz
t_{L_SEL}	Select Time			TBD		ms
t_{L_M}	PLL Lock Time			TBD		ms
t_R / t_F	Output Rise/Fall Time	Q/nQ	20% to 80%	500		ps
		REF_OUT	20% to 80%	500		ps
odc	Output Duty Cycle	Q/nQ		50		%
		REF_OUT		50		%

NOTE 1: Measured from the $V_{CC}/2$ of the input to $V_{CCO_LVCMOS}/2$ of the output.

NOTE 2: Phase jitter measured using a 19.44MHz quartz crystal.

NOTE 3: This parameter is defined in accordance with JEDEC Standard 65.

TABLE 6B. AC CHARACTERISTICS, $V_{CC} = V_{CCA} = 3.3V \pm 5\%$, $V_{CCO_LVPECL}, V_{CCO_LVCMOS} = 2.5V \pm 5\%$, $T_A = -40^\circ C$ to $85^\circ C$

Symbol	Parameter	Test Conditions	Minimum	Typical	Maximum	Units
f_{OUT}	Output Frequency		56		650	MHz
t_{PD}	Propagation Delay, NOTE 1	CLK to REF_OUT		TBD		ns
$f_{jit}(\emptyset)$	RMS Phase Jitter, (Random); NOTE 2, 3	622.08MHz (12kHz - 20MHz)		TBD		ps
f_{VCO}	PLL VCO Lock Range		1.12		1.3	GHz
t_{L_SEL}	Select Time			TBD		ms
t_{L_M}	PLL Lock Time			TBD		ms
t_R / t_F	Output Rise/Fall Time	Q/nQ	20% to 80%	500		ps
		REF_OUT	20% to 80%	500		ps
odc	Output Duty Cycle	Q/nQ		50		%
		REF_OUT		50		%

NOTE 1: Measured from the $V_{CC}/2$ of the input to $V_{CCO_LVCMOS}/2$ of the output.

NOTE 2: Phase jitter measured using a 19.44MHz quartz crystal.

NOTE 3: This parameter is defined in accordance with JEDEC Standard 65.



Integrated
Circuit
Systems, Inc.

PRELIMINARY

ICS843001I-23
FEMTOCLOCKS™ CRYSTAL-TO-3.3V LVPECL/LVCMOS
FREQUENCY SYNTHESIZER

TABLE 6C. AC CHARACTERISTICS, $V_{CC} = V_{CCA} = V_{CCO_LVPECL}, V_{CCO_LVCMOS} = 2.5V \pm 5\%$, $T_A = -40^\circ C$ TO $85^\circ C$

Symbol	Parameter	Test Conditions	Minimum	Typical	Maximum	Units
f_{OUT}	Output Frequency		56		650	MHz
t_{PD}	Propagation Delay, NOTE 1	CLK to REF_OUT		TBD		ns
$f_{jit}(\emptyset)$	RMS Phase Jitter, (Random); NOTE 2, 3	622.08MHz (12kHz - 20MHz)		TBD		ps
f_{VCO}	PLL VCO Lock Range		1.12		1.3	GHz
t_{L_SEL}	Select Time			TBD		ms
t_{L_PLL}	PLL Lock Time			TBD		ms
t_R / t_F	Output Rise/Fall Time	Q/nQ	20% to 80%	500		ps
		REF_OUT	20% to 80%	500		ps
odc	Output Duty Cycle	Q/nQ		50		%
		REF_OUT		50		%

NOTE 1: Measured from the $V_{CC}/2$ of the input to $V_{CCO_LVCMOS}/2$ of the output.

NOTE 2: Phase jitter measured using a 19.44MHz quartz crystal.

NOTE 3: This parameter is defined in accordance with JEDEC Standard 65.



PARAMETER MEASUREMENT INFORMATION

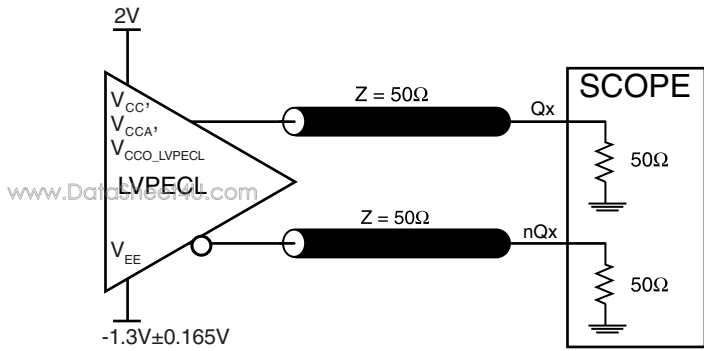

3.3V LVPECL OUTPUT LOAD AC TEST CIRCUIT

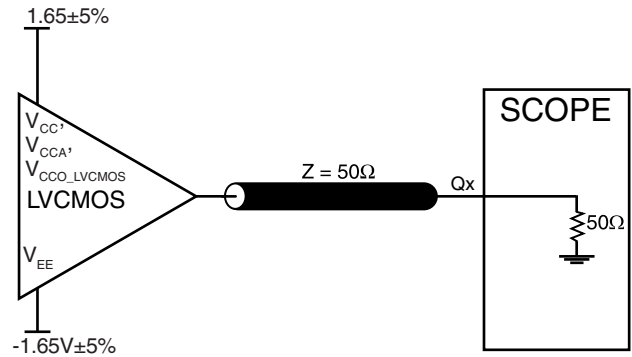

3.3V LVCMOS OUTPUT LOAD AC TEST CIRCUIT

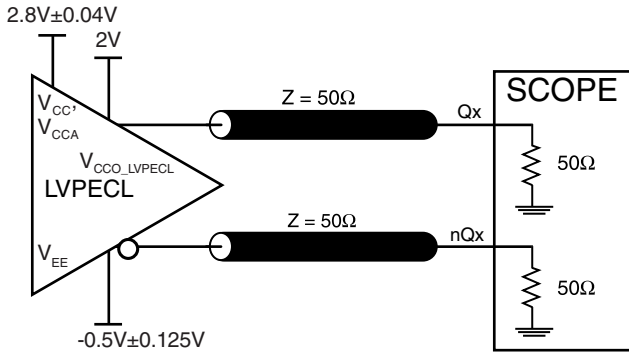

3.3V CORE/2.5V LVPECL OUTPUT LOAD AC TEST CIRCUIT

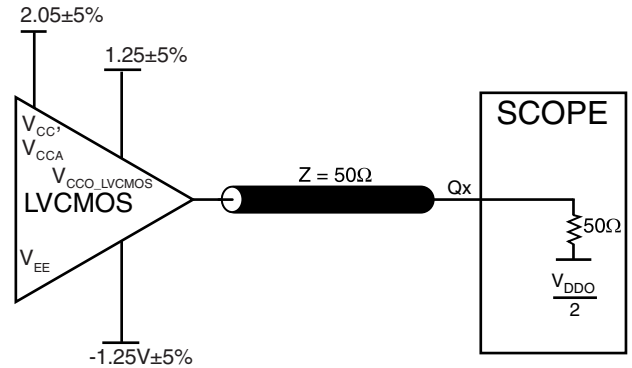

3.3V CORE/2.5V LVCMOS OUTPUT LOAD AC TEST CIRCUIT

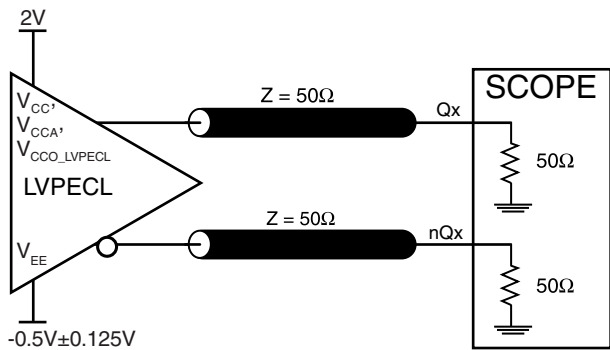

2.5V LVPECL OUTPUT LOAD AC TEST CIRCUIT

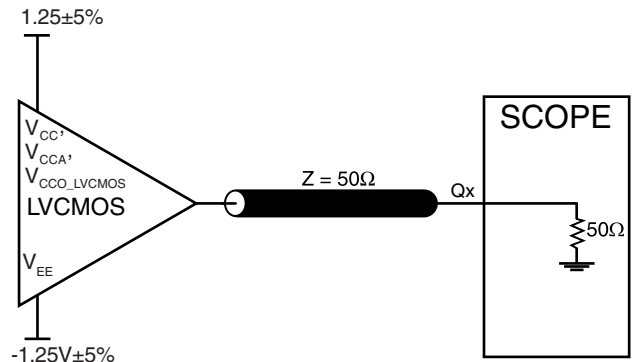

2.5V LVCMOS OUTPUT LOAD AC TEST CIRCUIT

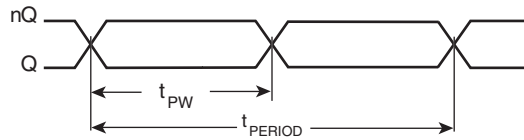
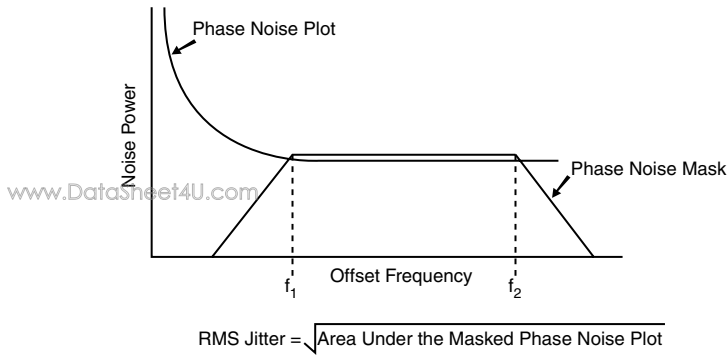

$$\text{odc} = \frac{t_{PW}}{t_{PERIOD}} \times 100\%$$

RMS PHASE JITTER

LVPECL OUTPUT DUTY CYCLE/PULSE WIDTH/PERIOD

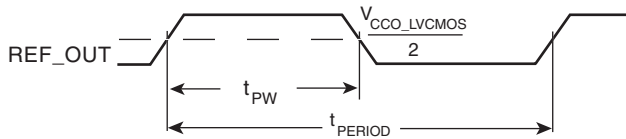

$$\text{odc} = \frac{t_{PW}}{t_{PERIOD}} \times 100\%$$

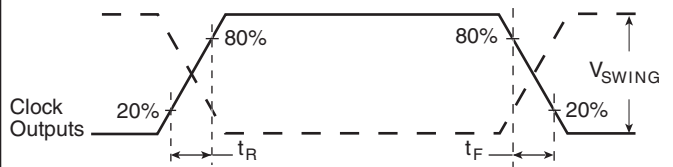

LVCMOS OUTPUT DUTY CYCLE/PULSE WIDTH/PERIOD

OUTPUT RISE/FALL TIME

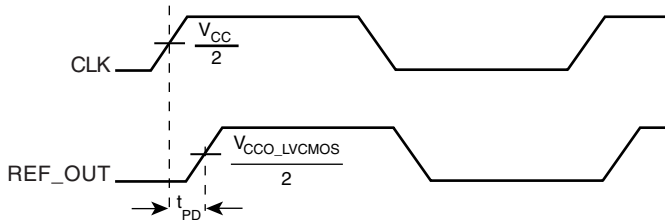

PROPAGATION DELAY



APPLICATION INFORMATION

POWER SUPPLY FILTERING TECHNIQUES

As in any high speed analog circuitry, the power supply pins are vulnerable to random noise. The ICS843001I-23 provides separate power supplies to isolate any high switching noise from the outputs to the internal PLL. V_{CC} , V_{CCA} , and V_{CCO_X} should be individually connected to the power supply plane through vias, and bypass capacitors should be used for each pin. To achieve optimum jitter performance, power supply isolation is required. *Figure 1* illustrates how a 10Ω resistor along with a $10\mu\text{F}$ and a $.01\mu\text{F}$ bypass capacitor should be connected to each V_{CCA} .

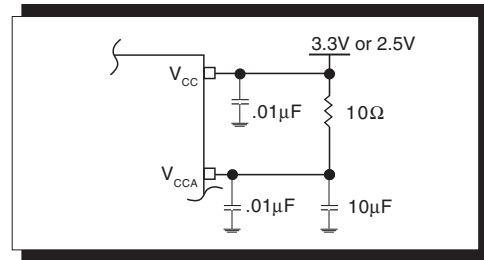

FIGURE 1. POWER SUPPLY FILTERING

RECOMMENDATIONS FOR UNUSED INPUT AND OUTPUT PINS

INPUTS:

CRYSTAL INPUT:

For applications not requiring the use of the crystal oscillator input, both XTAL_IN and XTAL_OUT can be left floating. Though not required, but for additional protection, a $1\text{k}\Omega$ resistor can be tied from XTAL_IN to ground.

CLK INPUT:

For applications not requiring the use of the test clock, it can be left floating. Though not required, but for additional protection, a $1\text{k}\Omega$ resistor can be tied from the CLK input to ground.

CONTROL PINS:

All control pins have internal pull-ups or pull-downs; additional resistance is not required but can be added for additional protection. A $1\text{k}\Omega$ resistor can be used.

OUTPUTS:

LVCMOS OUTPUT:

All unused LVCMOS output can be left floating. We recommend that there is no trace attached.

LVPECL OUTPUT

All unused LVPECL outputs can be left floating. We recommend that there is no trace attached. Both sides of the differential output pair should either be left floating or terminated.



CRYSTAL INPUT INTERFACE

The ICS843001I-23 has been characterized with 18pF parallel resonant crystals. The capacitor values shown in

Figure 2 below were determined using an 18pF parallel resonant crystal and were chosen to minimize the ppm error.

www.DataSheet4U.com

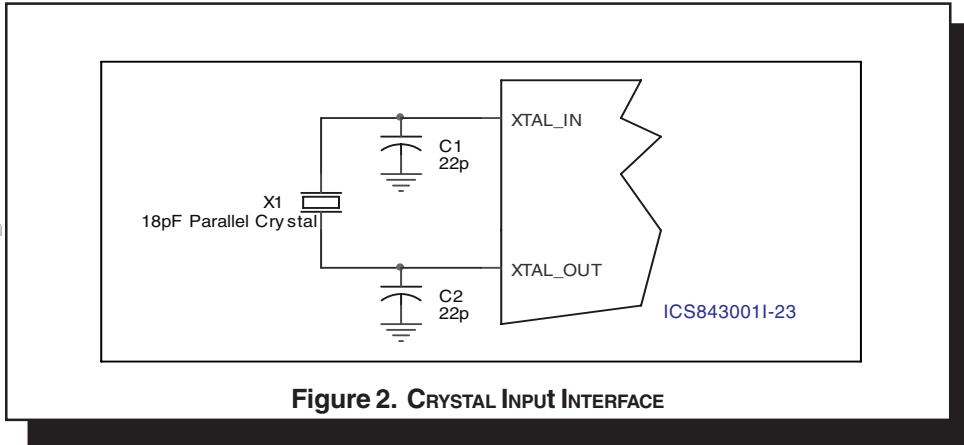

Figure 2. CRYSTAL INPUT INTERFACE

TERMINATION FOR 3.3V LVPECL OUTPUT

The clock layout topology shown below is a typical termination for LVPECL outputs. The two different layouts mentioned are recommended only as guidelines.

FOUT and nFOUT are low impedance follower outputs that generate ECL/LVPECL compatible outputs. Therefore, terminating resistors (DC current path to ground) or current sources must be used for functionality. These

outputs are designed to drive 50Ω transmission lines. Matched impedance techniques should be used to maximize operating frequency and minimize signal distortion. Figures 3A and 3B show two different layouts which are recommended only as guidelines. Other suitable clock layouts may exist and it would be recommended that the board designers simulate to guarantee compatibility across all printed circuit and clock component process variations.

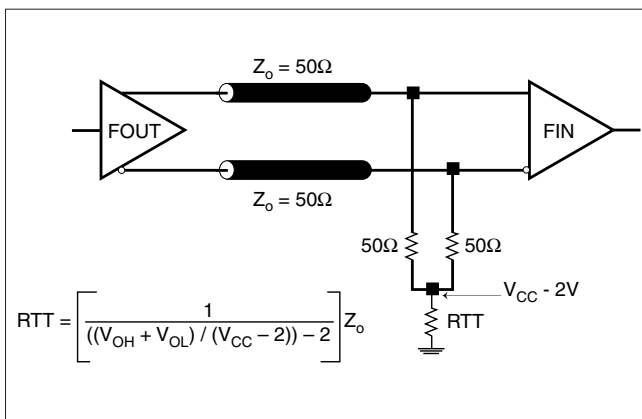

FIGURE 3A. LVPECL OUTPUT TERMININATION

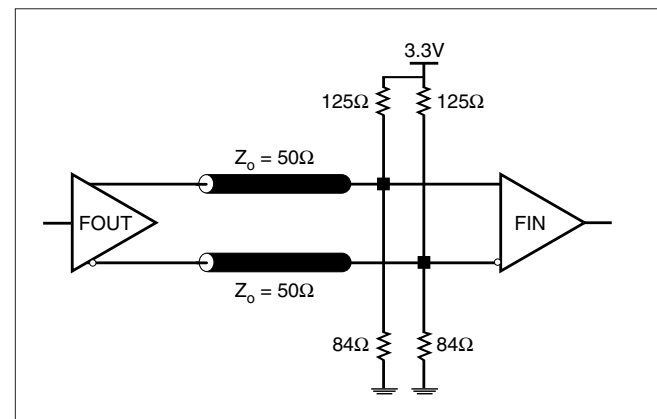

FIGURE 3B. LVPECL OUTPUT TERMININATION



TERMINATION FOR 2.5V LVPECL OUTPUT

Figure 4A and Figure 4B show examples of termination for 2.5V LVPECL driver. These terminations are equivalent to terminating 50Ω to $V_{CC} - 2V$. For $V_{CC} = 2.5V$, the $V_{CC} - 2V$ is very

close to ground level. The R3 in Figure 4B can be eliminated and the termination is shown in Figure 4C.

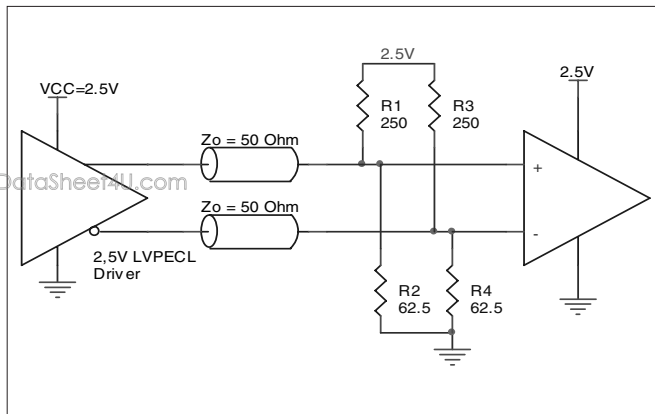

FIGURE 4A. 2.5V LVPECL DRIVER TERMINATION EXAMPLE

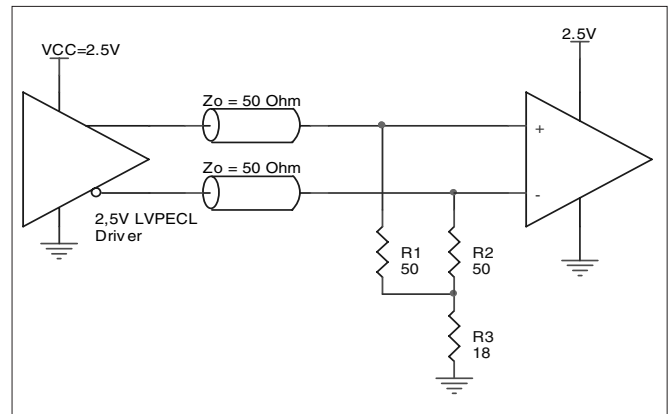

FIGURE 4B. 2.5V LVPECL DRIVER TERMINATION EXAMPLE

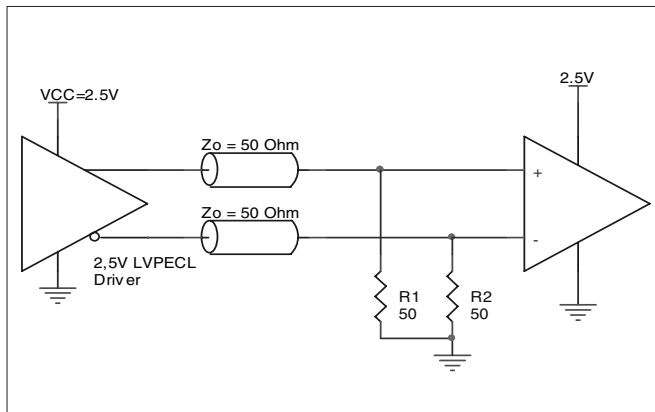

FIGURE 4C. 2.5V LVPECL TERMINATION EXAMPLE



Integrated
Circuit
Systems, Inc.

PRELIMINARY

ICS843001I-23
FEMTOCLOCKS™ CRYSTAL-TO-3.3V LVPECL/LVCMOS
FREQUENCY SYNTHESIZER

RELIABILITY INFORMATION

TABLE 7. θ_{JA} vs. AIR FLOW TABLE FOR 24 LEAD TSSOP

θ_{JA} by Velocity (Meters per Second)			
	0	1	2.5
Multi-Layer PCB, JEDEC Standard Test Boards	70°C/W	65°C/W	62°C/W

TRANSISTOR COUNT

The transistor count for ICS843001I-23 is: 4165



PACKAGE OUTLINE - G SUFFIX FOR 24 LEAD TSSOP

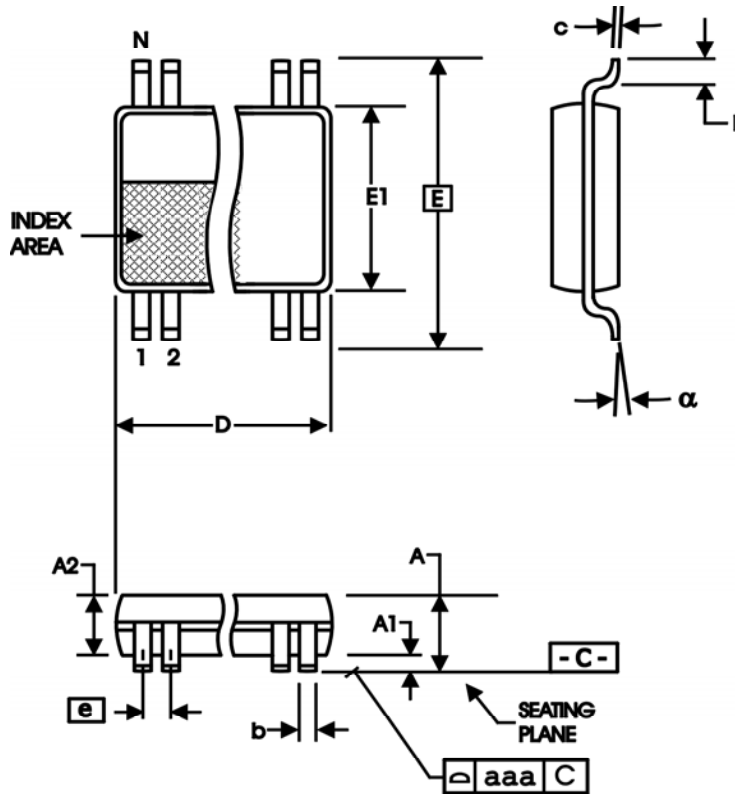

www.DataSheet4U.com

TABLE 8. PACKAGE DIMENSIONS

SYMBOL	Millimeters	
	Minimum	Maximum
N	24	
A	--	1.20
A1	0.05	0.15
A2	0.80	1.05
b	0.19	0.30
c	0.09	0.20
D	7.70	7.90
E	6.40 BASIC	
E1	4.30	4.50
e	0.65 BASIC	
L	0.45	0.75
α	0°	8°
aaa	--	0.10

Reference Document: JEDEC Publication 95, MO-153



Integrated
Circuit
Systems, Inc.

PRELIMINARY

ICS843001I-23
FEMTOCLOCKS™ CRYSTAL-TO-3.3V LVPECL/LVCMOS
FREQUENCY SYNTHESIZER

TABLE 9. ORDERING INFORMATION

Part/Order Number	Marking	Package	Shipping Packaging	Temperature
ICS843001AGI-23	ICS843001AI23	24 Lead TSSOP	tube	-40°C to 85°C
ICS843001AGI-23T	ICS843001AI23	24 Lead TSSOP	2500 tape & reel	-40°C to 85°C
ICS843001AGI-23LF	TBD	24 Lead "Lead-Free" TSSOP	tube	-40°C to 85°C
ICS843001AGI-23LFT	TBD	24 Lead "Lead-Free" TSSOP	2500 tape & reel	-40°C to 85°C

NOTE: Parts that are ordered with an "LF" suffix to the part number are the Pb-Free configuration and are RoHS compliant.

www.DataSheet4U.com

The aforementioned trademarks, HiPerClockS and FemtoClocks are trademarks of Integrated Circuit Systems, Inc. or its subsidiaries in the United States and/or other countries.

While the information presented herein has been checked for both accuracy and reliability, Integrated Circuit Systems, Incorporated (ICS) assumes no responsibility for either its use or for infringement of any patents or other rights of third parties, which would result from its use. No other circuits, patents, or licenses are implied. This product is intended for use in normal commercial and industrial applications. Any other applications such as those requiring high reliability or other extraordinary environmental requirements are not recommended without additional processing by ICS. ICS reserves the right to change any circuitry or specifications without notice. ICS does not authorize or warrant any ICS product for use in life support devices or critical medical instruments.