



Integrated  
Circuit  
Systems, Inc.

**PRELIMINARY**

# ICS8432-51K

## 700MHz, CRYSTAL-TO-3.3V DIFFERENTIAL LVPECL FREQUENCY SYNTHESIZER

### GENERAL DESCRIPTION



The ICS8432-51K is a general purpose, dual output Crystal-to-3.3V Differential LVPECL High Frequency Synthesizer and a member of the HiPerClockS™ family of High Performance Clock Solutions from ICS. The ICS8432-51K has a selectable TEST\_CLK or crystal input. The VCO operates at a frequency range of 250MHz to 700MHz. The VCO frequency is programmed in steps equal to the value of the input reference or crystal frequency. The VCO and output frequency can be programmed using the serial or parallel interface to the configuration logic. The low phase noise characteristics of the ICS8432-51K make it an ideal clock source for Gigabit Ethernet, Fibre Channel 1 and 2, and Infiniband applications.

### FEATURES

- Dual differential 3.3V LVPECL outputs
- Selectable crystal oscillator interface or LVCMOS/LVTTL TEST\_CLK
- Output frequency range: 31.25MHz to 700MHz
- Crystal input frequency range: 12MHz to 25MHz
- VCO range: 250MHz to 700MHz
- Parallel or serial interface for programming counter and output dividers
- RMS period jitter: 3.5ps (maximum)
- Cycle-to-cycle jitter: 25ps (maximum)
- 3.3V supply voltage
- 0°C to 70°C ambient operating temperature
- Replaces the ICS8432-01

### BLOCK DIAGRAM

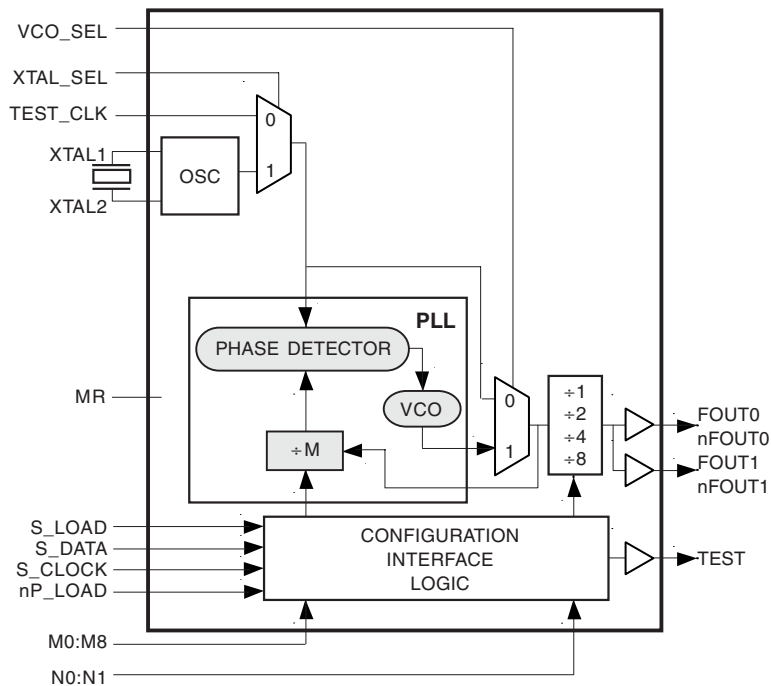

### PIN ASSIGNMENT

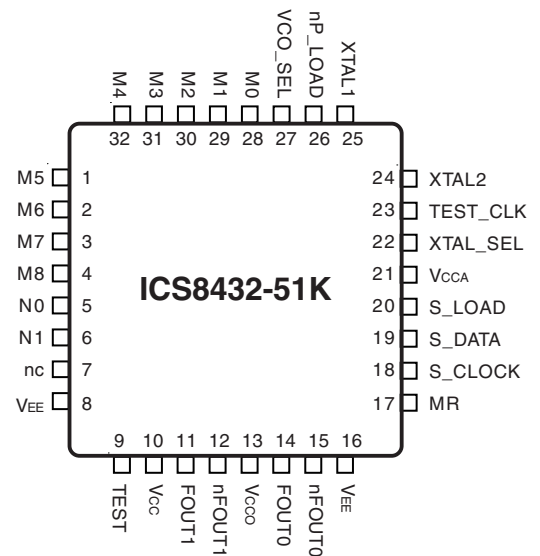

**32-Lead VFQFN**  
5mm x 5mm x 0.95mm package body  
**K Package**  
Top View

The Preliminary Information presented herein represents a product in prototyping or pre-production. The noted characteristics are based on initial product characterization. Integrated Circuit Systems, Incorporated (ICS) reserves the right to change any circuitry or specifications without notice.



**FUNCTIONAL DESCRIPTION**

*NOTE: The functional description that follows describes operation using a 25MHz crystal. Valid PLL loop divider values for different crystal or input frequencies are defined in the Input Frequency Characteristics, Table 5, NOTE 1.*

The ICS8432-51K features a fully integrated PLL and therefore requires no external components for setting the loop bandwidth. A fundamental crystal is used as the input to the on-chip oscillator. The output of the oscillator is fed into the phase detector. A 25MHz crystal provides a 25MHz phase detector reference frequency. The VCO of the PLL operates over a range of 250MHz to 700MHz. The output of the M divider is also applied to the phase detector.

The phase detector and the M divider force the VCO output frequency to be M times the reference frequency by adjusting the VCO control voltage. Note that for some values of M (either too high or too low), the PLL will not achieve lock. The output of the VCO is scaled by a divider prior to being sent to each of the LVPECL output buffers. The divider provides a 50% output duty cycle.

The programmable features of the ICS8432-51K support two input modes to program the M divider and N output divider. The two input operational modes are parallel and serial. *Figure 1* shows the timing diagram for each mode. In parallel mode, the nP\_LOAD input is initially LOW. The data on inputs M0 through M8 and N0 and N1 is passed directly to the M divider and N output divider. On the LOW-to-HIGH transition of the nP\_LOAD input, the data is latched and the M divider remains loaded until the next LOW transition on nP\_LOAD or until a serial event occurs. As a result, the M and N bits can be hardwired to set the

M divider and N output divider to a specific default state that will automatically occur during power-up. The TEST output is LOW when operating in the parallel input mode. The relationship between the VCO frequency, the crystal frequency and the M divider is defined as follows:  $f_{VCO} = f_{xtal} \times M$

The M value and the required values of M0 through M8 are shown in Table 3B, Programmable VCO Frequency Function Table. Valid M values for which the PLL will achieve lock for a 25MHz reference are defined as  $10 \leq M \leq 28$ . The frequency out is defined as follows:  $f_{OUT} = \frac{f_{VCO}}{N} = f_{xtal} \times \frac{M}{N}$

Serial operation occurs when nP\_LOAD is HIGH and S\_LOAD is LOW. The shift register is loaded by sampling the S\_DATA bits with the rising edge of S\_CLOCK. The contents of the shift register are loaded into the M divider and N output divider when S\_LOAD transitions from LOW-to-HIGH. The M divide and N output divide values are latched on the HIGH-to-LOW transition of S\_LOAD. If S\_LOAD is held HIGH, data at the S\_DATA input is passed directly to the M divider and N output divider on each rising edge of S\_CLOCK. The serial mode can be used to program the M and N bits and test bits T1 and T0. The internal registers T0 and T1 determine the state of the TEST output as follows:

T1	T0	TEST Output
0	0	LOW
0	1	S_Data, Shift Register Input
1	0	Output of M divider
1	1	CMOS Fout

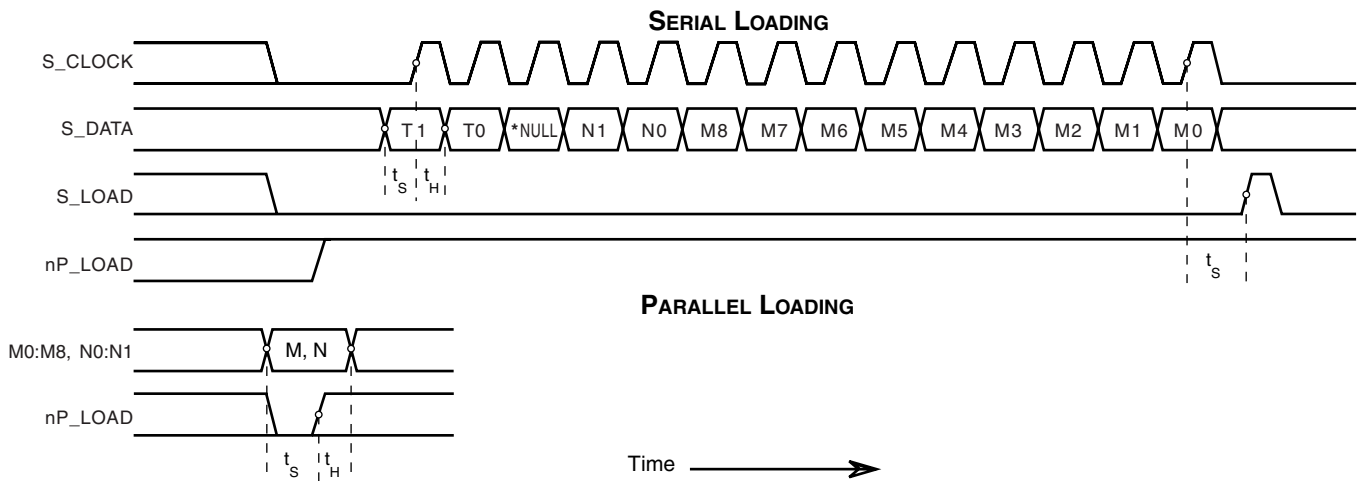

**FIGURE 1. PARALLEL & SERIAL LOAD OPERATIONS**

\*NOTE: The NULL timing slot must be observed.



**TABLE 1. PIN DESCRIPTIONS**

Number	Name	Type		Description
1	M5	Input	Pullup	M divider inputs. Data latched on LOW-to-HIGH transition of nP_LOAD input. LVCMOS / LVTTTL interface levels.
2, 3, 4, 28, 29, 30, 31, 32	M6, M7, M8, M0, M1, M2, M3, M4	Input	Pulldown	
5, 6	N0, N1	Input	Pulldown	Determines output divider value as defined in Table 3C, Function Table. LVCMOS / LVTTTL interface levels.
7	nc	Unused		No connect.
8, 16	V <sub>EE</sub>	Power		Negative supply pins.
9	TEST	Output		Test output which is ACTIVE in the serial mode of operation. Output driven LOW in parallel mode. LVCMOS / LVTTTL interface levels.
10	V <sub>CC</sub>	Power		Core supply pin.
11, 12	FOUT1, nFOUT1	Output		Differential output for the synthesizer. 3.3V LVPECL interface levels.
13	V <sub>CCO</sub>	Power		Output supply pin.
14, 15	FOUT0, nFOUT0	Output		Differential output for the synthesizer. 3.3V LVPECL interface levels.
17	MR	Input	Pulldown	Active High Master Reset. When logic HIGH, the internal dividers are reset causing the true outputs FOUTx to go low and the inverted outputs nFOUTx to go high. When logic LOW, the internal dividers and the outputs are enabled. Assertion of MR does not effect loaded M, N, and T values. LVCMOS / LVTTTL interface levels.
18	S_CLOCK	Input	Pulldown	Clocks in serial data present at S_DATA input into the shift register on the rising edge of S_CLOCK. LVCMOS / LVTTTL interface levels.
19	S_DATA	Input	Pulldown	Shift register serial input. Data sampled on the rising edge of S_CLOCK. LVCMOS / LVTTTL interface levels.
20	S_LOAD	Input	Pulldown	Controls transition of data from shift register into the dividers. LVCMOS / LVTTTL interface levels.
21	V <sub>CCA</sub>	Power		Analog supply pin.
22	XTAL_SEL	Input	Pullup	Selects between crystal or test inputs as the PLL reference source. Selects XTAL inputs when HIGH. Selects TEST_CLK when LOW. LVCMOS / LVTTTL interface levels
23	TEST_CLK	Input	Pulldown	Test clock input. LVCMOS / LVTTTL interface levels.
24, 25	XTAL2, XTAL1	Input		Crystal oscillator interface. XTAL1 is the input. XTAL2 is the output.
26	nP_LOAD	Input	Pulldown	Parallel load input. Determines when data present at M8:M0 is loaded into M divider, and when data present at N1:N0 sets the N output divider value. LVCMOS / LVTTTL interface levels.
27	VCO_SEL	Input	Pullup	Determines whether synthesizer is in PLL or bypass mode. LVCMOS / LVTTTL interface levels.

NOTE: *Pullup* and *Pulldown* refer to internal input resistors. See Table 2, Pin Characteristics, for typical values.

**TABLE 2. PIN CHARACTERISTICS**

Symbol	Parameter	Test Conditions	Minimum	Typical	Maximum	Units
C <sub>IN</sub>	Input Capacitance			4		pF
R <sub>PULLUP</sub>	Input Pullup Resistor			51		KΩ
R <sub>PULLDOWN</sub>	Input Pulldown Resistor			51		KΩ



**TABLE 3A. PARALLEL AND SERIAL MODE FUNCTION TABLE**

Inputs							Conditions
MR	nP_LOAD	M	N	S_LOAD	S_CLOCK	S_DATA	
H	X	X	X	X	X	X	Reset. Forces outputs LOW.
L	L	Data	Data	X	X	X	Data on M and N inputs passed directly to the M divider and N output divider. TEST output forced LOW.
L	↑	Data	Data	L	X	X	Data is latched into input registers and remains loaded until next LOW transition or until a serial event occurs.
L	H	X	X	L	↑	Data	Serial input mode. Shift register is loaded with data on S_DATA on each rising edge of S_CLOCK.
L	H	X	X	↑	L	Data	Contents of the shift register are passed to the M divider and N output divider.
L	H	X	X	↓	L	Data	M divider and N output divider values are latched.
L	H	X	X	L	X	X	Parallel or serial input do not affect shift registers.
L	H	X	X	H	↑	Data	S_DATA passed directly to M divider as it is clocked.

NOTE: L = LOW  
H = HIGH  
X = Don't care  
↑ = Rising edge transition  
↓ = Falling edge transition

**TABLE 3B. PROGRAMMABLE VCO FREQUENCY FUNCTION TABLE**

VCO Frequency (MHz)	M Divide	256	128	64	32	16	8	4	2	1
		M8	M7	M6	M5	M4	M3	M2	M1	M0
250	10	0	0	0	0	0	1	0	1	0
275	11	0	0	0	0	0	1	0	1	1
•	•	•	•	•	•	•	•	•	•	•
•	•	•	•	•	•	•	•	•	•	•
650	26	0	0	0	0	1	1	0	1	0
675	27	0	0	0	0	1	1	0	1	1
700	28	0	0	0	0	1	1	1	0	0

NOTE 1: These M divide values and the resulting frequencies correspond to crystal or TEST\_CLK input frequency of 25MHz.

**TABLE 3C. PROGRAMMABLE OUTPUT DIVIDER FUNCTION TABLE**

Inputs		N Divider Value	Output Frequency (MHz)	
N1	N0		Minimum	Maximum
0	0	1	250	700
0	1	2	125	350
1	0	4	62.5	175
1	1	8	31.25	87.5



**ABSOLUTE MAXIMUM RATINGS**

Supply Voltage, $V_{CC}$	4.6V
Inputs, $V_I$	-0.5V to $V_{CC} + 0.5V$
Outputs, $I_O$	
Continuous Current	50mA
Surge Current	100mA
Package Thermal Impedance, $\theta_{JA}$	41.07°C/W (0 lfpm)
Storage Temperature, $T_{STG}$	-65°C to 150°C

NOTE: Stresses beyond those listed under Absolute Maximum Ratings may cause permanent damage to the device. These ratings are stress specifications only. Functional operation of product at these conditions or any conditions beyond those listed in the *DC Characteristics* or *AC Characteristics* is not implied. Exposure to absolute maximum rating conditions for extended periods may affect product reliability.

**TABLE 4A. POWER SUPPLY DC CHARACTERISTICS,  $V_{CC} = V_{CCA} = V_{CCO} = 3.3V \pm 5\%$ ,  $T_A = 0^\circ C$  TO  $70^\circ C$**

Symbol	Parameter	Test Conditions	Minimum	Typical	Maximum	Units
$V_{CC}$	Core Supply Voltage		3.135	3.3	3.465	V
$V_{CCA}$	Analog Supply Voltage		3.135	3.3	3.465	V
$V_{CCO}$	Output Supply Voltage		3.135	3.3	3.465	V
$I_{EE}$	Power Supply Current				135	mA
$I_{CCA}$	Analog Supply Current				15	mA

**TABLE 4B. LVCMOS / LVTTTL DC CHARACTERISTICS,  $V_{CC} = V_{CCA} = V_{CCO} = 3.3V \pm 5\%$ ,  $T_A = 0^\circ C$  TO  $70^\circ C$**

Symbol	Parameter	Test Conditions	Minimum	Typical	Maximum	Units
$V_{IH}$	Input High Voltage	VCO_SEL, XTAL_SEL, MR, S_LOAD, nP_LOAD, N0:N1, S_DATA, S_CLOCK, M0:M8	2		$V_{CC} + 0.3$	V
		TEST_CLK	2		$V_{CC} + 0.3$	V
$V_{IL}$	Input Low Voltage	VCO_SEL, XTAL_SEL, MR, S_LOAD, nP_LOAD, N0:N1, S_DATA, S_CLOCK, M0:M8	-0.3		0.8	V
		TEST_CLK	-0.3		1.3	V
$I_{IH}$	Input High Current	M0-M4, M6-M8, N0, N1, MR, S_CLOCK, TEST_CLK, S_DATA, S_LOAD, nP_LOAD	$V_{CC} = V_{IN} = 3.465V$		150	$\mu A$
		M5, XTAL_SEL, VCO_SEL	$V_{CC} = V_{IN} = 3.465V$		5	$\mu A$
$I_{IL}$	Input Low Current	M0-M4, M6-M8, N0, N1, MR, S_CLOCK, TEST_CLK, S_DATA, S_LOAD, nP_LOAD	$V_{CC} = 3.465V,$ $V_{IN} = 0V$	-5		$\mu A$
		M5, XTAL_SEL, VCO_SEL	$V_{CC} = 3.465V,$ $V_{IN} = 0V$	-150		$\mu A$
$V_{OH}$	Output High Voltage	TEST; NOTE 1	2.6			V
$V_{OL}$	Output Low Voltage	TEST; NOTE 1			0.5	V

NOTE 1: Outputs terminated with 50Ω to  $V_{CCO}/2$ .



**TABLE 4C. LVPECL DC CHARACTERISTICS,  $V_{CC} = V_{CCA} = V_{CCO} = 3.3V \pm 5\%$ ,  $T_A = 0^\circ C$  TO  $70^\circ C$**

Symbol	Parameter	Test Conditions	Minimum	Typical	Maximum	Units
$V_{OH}$	Output High Voltage; NOTE 1		$V_{CCO} - 1.4$		$V_{CCO} - 0.9$	V
$V_{OL}$	Output Low Voltage; NOTE 1		$V_{CCO} - 2.0$		$V_{CCO} - 1.7$	V
$V_{SWING}$	Peak-to-Peak Output Voltage Swing		0.6		1.0	V

NOTE 1: Outputs terminated with  $50 \Omega$  to  $V_{CCO} - 2V$ . See "Parameter Measurement Information" section, figure "3.3V Output Load Test Circuit".

**TABLE 5. INPUT FREQUENCY CHARACTERISTICS,  $V_{CC} = V_{CCA} = V_{CCO} = 3.3V \pm 5\%$ ,  $T_A = 0^\circ C$  TO  $70^\circ C$**

Symbol	Parameter	Test Conditions	Minimum	Typical	Maximum	Units
$f_{IN}$	Input Frequency	TEST_CLK; NOTE 1	12		25	MHz
		XTAL1, XTAL2; NOTE 1	12		25	MHz
		S_CLOCK			50	MHz

NOTE 1: For the input crystal and TEST\_CLK frequency range, the M value must be set for the VCO to operate within the 250MHz to 700MHz range. Using the minimum input frequency of 12MHz, valid values of M are  $21 \leq M \leq 58$ . Using the maximum frequency of 25MHz, valid values of M are  $10 \leq M \leq 28$ .

**TABLE 6. CRYSTAL CHARACTERISTICS**

Parameter	Test Conditions	Minimum	Typical	Maximum	Units
Mode of Oscillation		Fundamental			
Frequency		12		25	MHz
Equivalent Series Resistance (ESR)				70	$\Omega$
Shunt Capacitance				7	pF

**TABLE 7. AC CHARACTERISTICS,  $V_{CC} = V_{CCA} = V_{CCO} = 3.3V \pm 5\%$ ,  $T_A = 0^\circ C$  TO  $70^\circ C$**

Symbol	Parameter	Test Conditions	Minimum	Typical	Maximum	Units
$F_{OUT}$	Output Frequency		31.25		700	MHz
$f_{jit(cc)}$	Cycle-to-Cycle Jitter; NOTE 1, 3	$f_{VCO} > 350MHz$			25	ps
$f_{jit(per)}$	Period Jitter, RMS; NOTE 1				3.5	ps
$t_{sk(o)}$	Output Skew; NOTE 2, 3				15	ps
$t_R / t_F$	Output Rise/Fall Time	20% to 80%	200		700	ps
$t_s$	Setup Time	M, N to nP_LOAD	5			ns
		S_DATA to S_CLOCK	5			ns
		S_CLOCK to S_LOAD	5			ns
$t_H$	Hold Time	M, N to nP_LOAD	5			ns
		S_DATA to S_CLOCK	5			ns
		S_CLOCK to S_LOAD	5			ns
odc	Output Duty Cycle	$N > 1$	48		52	%
$t_{PW}$	Output Pulse Width	$N = 1$	$t_{PERIOD} / 2 - 150$		$t_{PERIOD} / 2 + 150$	ps
$t_{LOCK}$	PLL Lock Time				1	ms

See Parameter Measurement Information section.

NOTE 1: Jitter performance using XTAL inputs.

NOTE 2: Defined as skew between outputs at the same supply voltage and with equal load conditions. Measured at the output differential cross points.

NOTE 3: This parameter is defined in accordance with JEDEC Standard 65.



**PARAMETER MEASUREMENT INFORMATION**

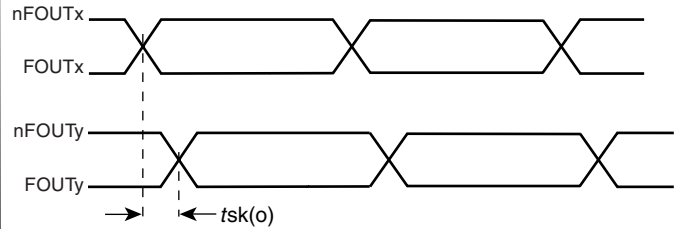
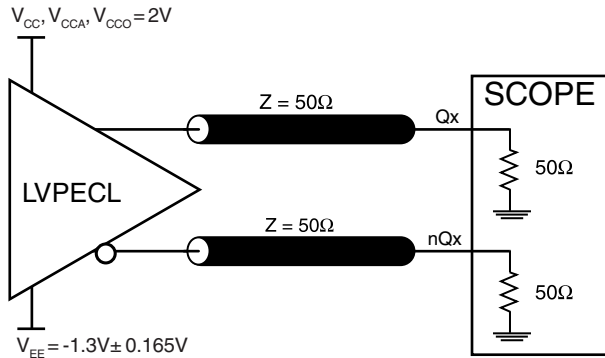

**3.3V OUTPUT LOAD AC TEST CIRCUIT**

**OUTPUT SKEW**

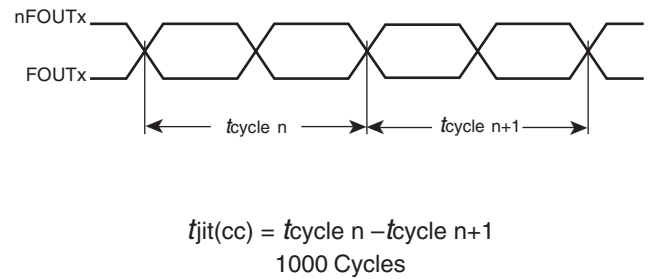
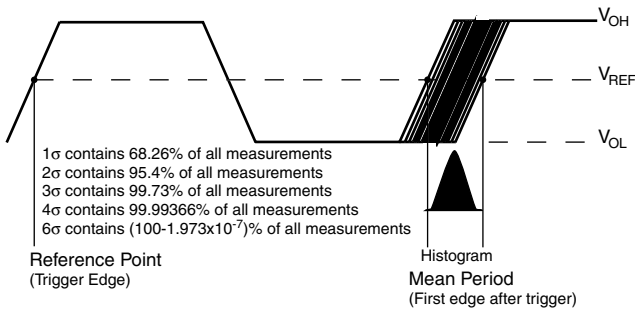

**PERIOD JITTER**

**CYCLE-TO-CYCLE JITTER**

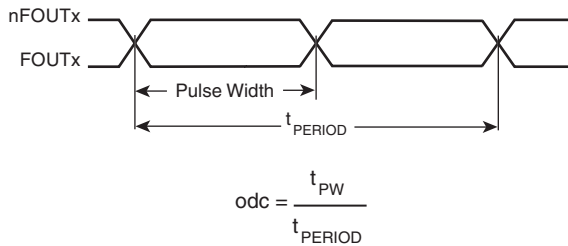

**odc &  $t_{PERIOD}$**

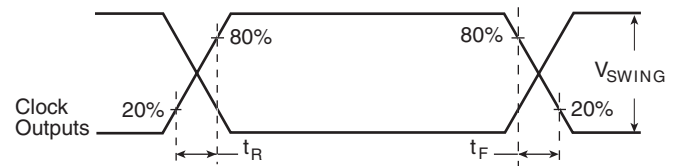

**OUTPUT RISE/FALL TIME**





**APPLICATION INFORMATION**

**STORAGE AREA NETWORKS**

A variety of technologies are used for interconnection of the elements within a SAN. The tables below lists the common frequencies used as well as the settings for the ICS8432-51K to generate the appropriate frequency.

**Table 8. Common SANs Application Frequencies**

Interconnect Technology	Clock Rate	Reference Frequency to SERDES (MHz)	Crystal Frequency (MHz)
Gigabit Ethernet	1.25 GHz	125, 250, 156.25	25, 19.53125
Fibre Channel	FC1 1.0625 GHz FC2 2.1250 GHz	106.25, 53.125, 132.8125	16.6015625, 25
Infiniband	2.5 GHz	125, 250	25

**Table 9. Configuration Details for SANs Applications**

Interconnect Technology	Crystal Frequency (MHz)	ICS8432-51K Output Frequency to SERDES (MHz)	ICS8432-51K M & N Settings										
			M8	M7	M6	M5	M4	M3	M2	M1	M0	N1	N0
Gigabit Ethernet	25	125	0	0	0	0	1	0	1	0	0	1	0
	25	250	0	0	0	0	1	0	1	0	0	0	1
	25	156.25	0	0	0	0	1	1	0	0	1	1	0
	19.53125	156.25	0	0	0	1	0	0	0	0	0	1	0
Fiber Channel 1	25	53.125	0	0	0	0	1	0	0	0	1	1	1
	25	106.25	0	0	0	0	1	0	0	0	1	1	0
Fiber Channel 2	16.6015625	132.8125	0	0	0	1	0	0	0	0	0	1	0
Infiniband	25	125	0	0	0	0	1	0	1	0	0	1	0
	25	250	0	0	0	0	1	0	1	0	0	0	1

**POWER SUPPLY FILTERING TECHNIQUES**

As in any high speed analog circuitry, the power supply pins are vulnerable to random noise. The ICS8432-51K provides separate power supplies to isolate any high switching noise from the outputs to the internal PLL.  $V_{CC}$ ,  $V_{CCA}$ , and  $V_{CCO}$  should be individually connected to the power supply plane through vias, and bypass capacitors should be used for each pin. To achieve optimum jitter performance, power supply isolation is required. Figure 2 illustrates how a 10Ω resistor along with a 10μF and a .01μF bypass capacitor should be connected to each  $V_{CCA}$  pin.

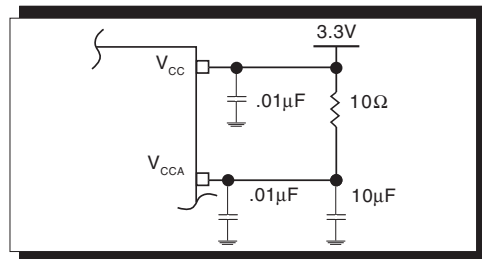

**FIGURE 2. POWER SUPPLY FILTERING**





**CRYSTAL INPUT INTERFACE**

The ICS8432-51K has been characterized with 18pF parallel resonant crystals. The capacitor values, C1 and C2, shown in *Figure 3* below were determined using a 25MHz, 18pF parallel resonant crystal and

were chosen to minimize the ppm error. The optimum C1 and C2 values can be slightly adjusted for different board layouts.

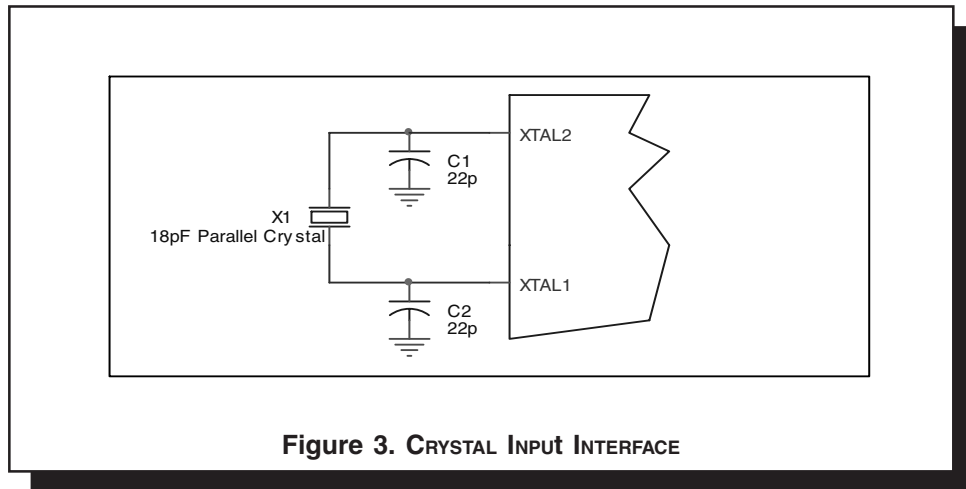

**Figure 3. CRYSTAL INPUT INTERFACE**

**TERMINATION FOR LVPECL OUTPUTS**

The clock layout topology shown below is a typical termination for LVPECL outputs. The two different layouts mentioned are recommended only as guidelines.

FOUTx and nFOUTx are low impedance follower outputs that generate ECL/LVPECL compatible outputs. Therefore, terminating resistors (DC current path to ground) or current sources must be used for functionality. These outputs are designed to

drive 50Ω transmission lines. Matched impedance techniques should be used to maximize operating frequency and minimize signal distortion. *Figures 4A and 4B* show two different layouts which are recommended only as guidelines. Other suitable clock layouts may exist and it would be recommended that the board designers simulate to guarantee compatibility across all printed circuit and clock component process variations.

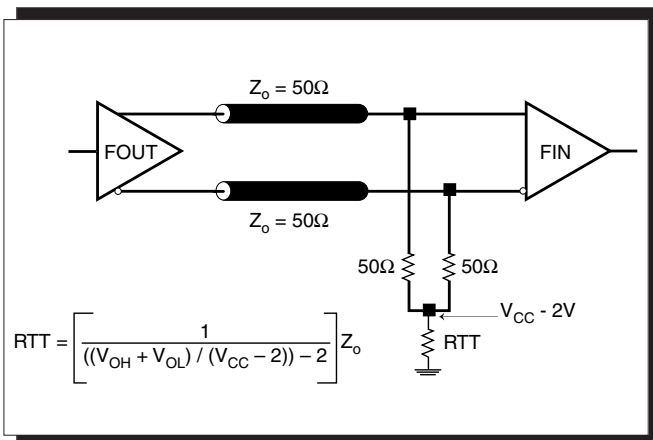

**FIGURE 4A. LVPECL OUTPUT TERMININATION**

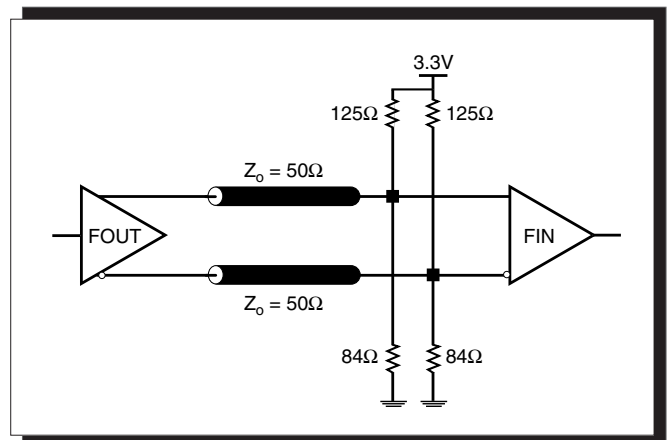

**FIGURE 4B. LVPECL OUTPUT TERMININATION**



**LAYOUT GUIDELINE**

The schematic of the ICS8432-51K layout example used in this layout guideline is shown in Figure 5A. The ICS8432-51K recommended PCB board layout for this example is shown in Figure 5B. This layout example is used as a general guideline.

The layout in the actual system will depend on the selected component types, the density of the components, the density of the traces, and the stack up of the P.C. board.

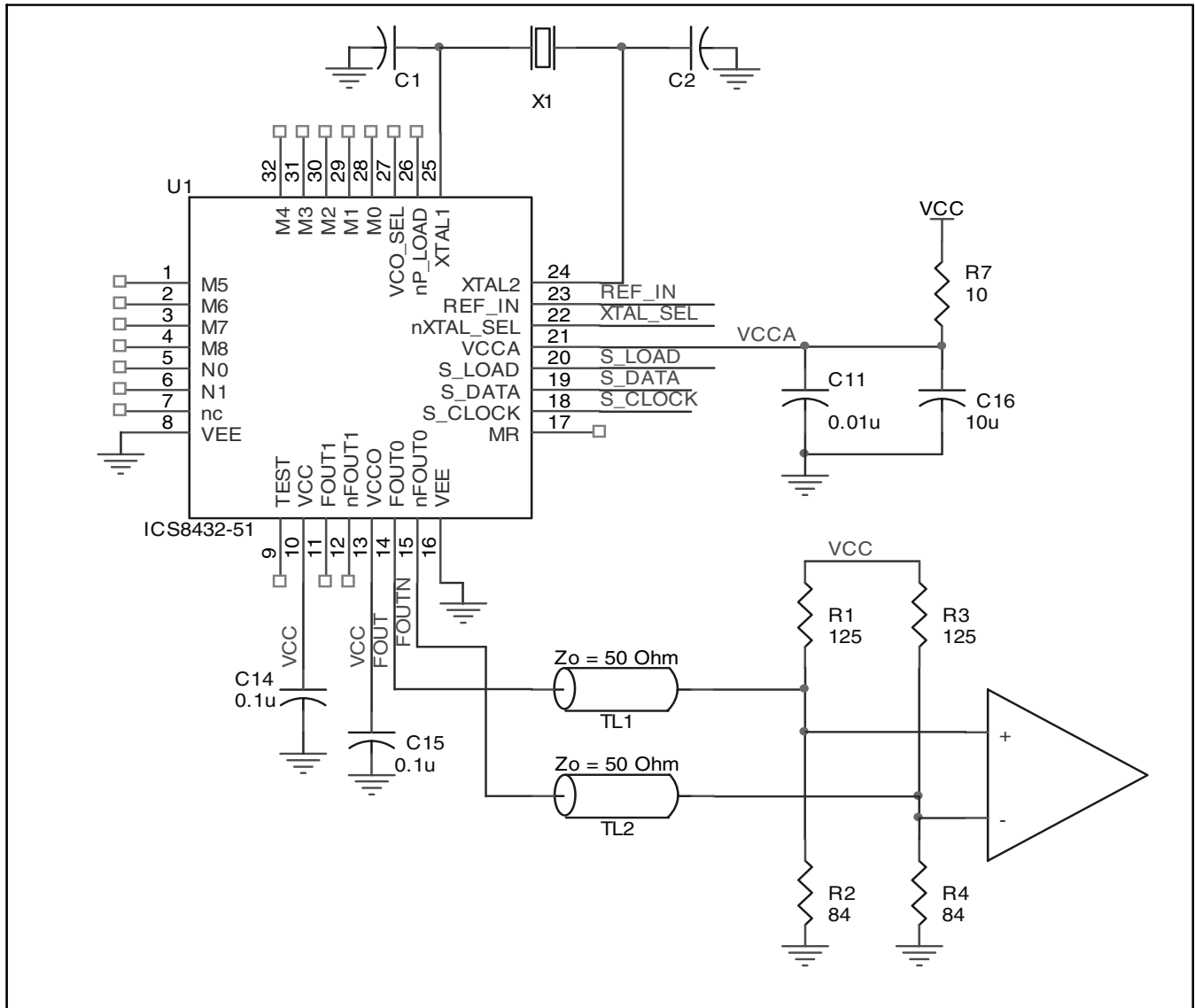

**FIGURE 5A. SCHEMATIC OF RECOMMENDED LAYOUT**



The following component footprints are used in this layout example:

All the resistors and capacitors are size 0603.

**POWER AND GROUNDING**

Place the decoupling capacitors C14 and C15, as close as possible to the power pins. If space allows, placement of the decoupling capacitor on the component side is preferred. This can reduce unwanted inductance between the decoupling capacitor and the power pin caused by the via.

Maximize the power and ground pad sizes and number of vias capacitors. This can reduce the inductance between the power and ground planes and the component power and ground pins.

The RC filter consisting of R7, C11, and C16 should be placed as close to the V<sub>CCA</sub> pin as possible.

**CLOCK TRACES AND TERMINATION**

Poor signal integrity can degrade the system performance or cause system failure. In synchronous high-speed digital systems, the clock signal is less tolerant to poor signal integrity than other signals. Any ringing on the rising or falling edge or excessive ring back can cause system failure. The shape of the trace and the trace delay might be restricted by the available space on the board and the component location. While routing the traces, the clock signal traces should be routed first and should be locked prior to routing other signal traces.

- The differential 50Ω output traces should have the same length.
- Avoid sharp angles on the clock trace. Sharp angle turns cause the characteristic impedance to change on the transmission lines.
- Keep the clock traces on the same layer. Whenever possible, avoid placing vias on the clock traces. Placement of vias on the traces can affect the trace characteristic impedance and hence degrade signal integrity.
- To prevent cross talk, avoid routing other signal traces in parallel with the clock traces. If running parallel traces is unavoidable, allow a separation of at least three trace widths between the differential clock trace and the other signal trace.
- Make sure no other signal traces are routed between the clock trace pair.
- The matching termination resistors should be located as close to the receiver input pins as possible.

**CRYSTAL**

The crystal X1 should be located as close as possible to the pins 24 (XTAL2) and 25 (XTAL1). The trace length between the X1 and U1 should be kept to a minimum to avoid unwanted parasitic inductance and capacitance. Other signal traces should not be routed near the crystal traces.

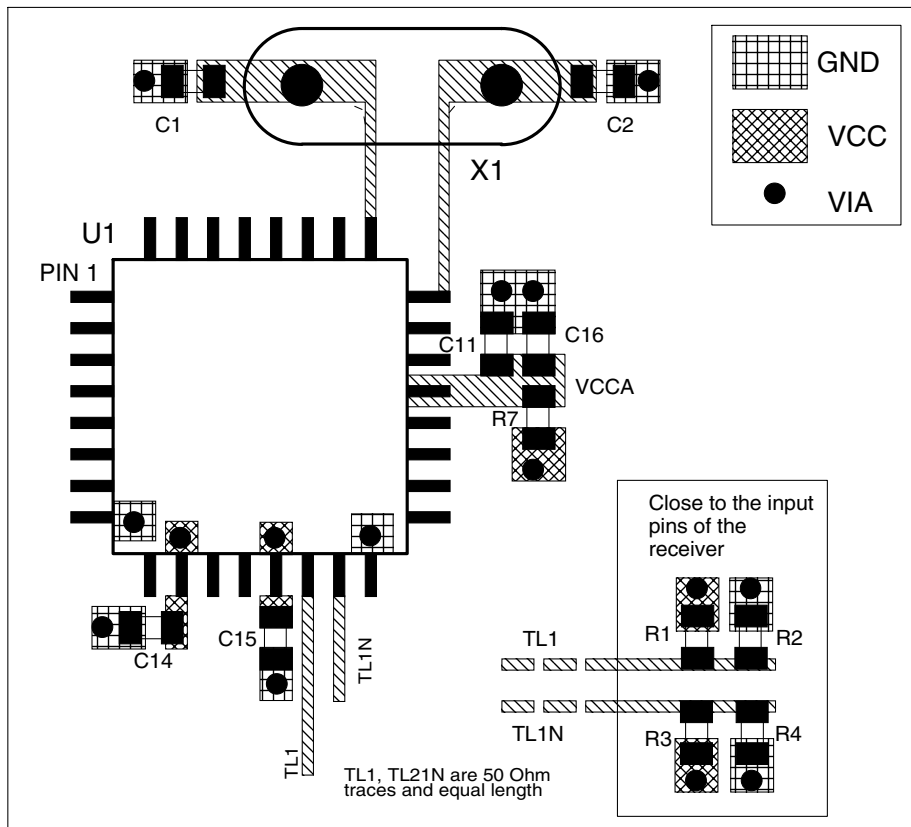

**FIGURE 5B. PCB BOARD LAYOUT FOR ICS8432-51K**



## POWER CONSIDERATIONS

This section provides information on power dissipation and junction temperature for the ICS8432-51K. Equations and example calculations are also provided.

### 1. Power Dissipation.

The total power dissipation for the ICS8432-51K is the sum of the core power plus the power dissipated in the load(s). The following is the power dissipation for  $V_{CC} = 3.3V + 5\% = 3.465V$ , which gives worst case results.

**NOTE:** Please refer to Section 3 for details on calculating power dissipated in the load.

- Power (core)<sub>MAX</sub> =  $V_{CC\_MAX} * I_{EE\_MAX} = 3.465V * 135mA = 467.8mW$
- Power (outputs)<sub>MAX</sub> = **30mW/Loaded Output pair**  
If all outputs are loaded, the total power is  $2 * 30mW = 60mW$

$$\text{Total Power}_{MAX} (3.465V, \text{ with all outputs switching}) = 467.8mW + 60mW = 527.8mW$$

### 2. Junction Temperature.

Junction temperature,  $T_j$ , is the temperature at the junction of the bond wire and bond pad and directly affects the reliability of the device. The maximum recommended junction temperature for HiPerClockS™ devices is 125°C.

The equation for  $T_j$  is as follows:  $T_j = \theta_{JA} * Pd_{total} + T_A$

$T_j$  = Junction Temperature

$\theta_{JA}$  = Junction-to-Ambient Thermal Resistance

$Pd_{total}$  = Total Device Power Dissipation (example calculation is in section 1 above)

$T_A$  = Ambient Temperature

In order to calculate junction temperature, the appropriate junction-to-ambient thermal resistance  $\theta_{JA}$  must be used. Assuming 0 air flow and a multi-layer board, the appropriate value is 41.07°C/W per Table 10 below.

Therefore,  $T_j$  for an ambient temperature of 70°C with all outputs switching is:

$$70^\circ C + 0.528W * 41.07^\circ C/W = 91.7^\circ C. \text{ This is well below the limit of } 125^\circ C.$$

This calculation is only an example.  $T_j$  will obviously vary depending on the number of loaded outputs, supply voltage, air flow, and the type of board (single layer or multi-layer).

**TABLE 10. THERMAL RESISTANCE  $\theta_{JA}$  FOR 32-PIN VFQFN, FORCED CONVECTION**

$\theta_{JA}$ by Velocity (Linear Feet per Minute)			
	0	200	500
Multi-Layer PCB, JEDEC Standard Test Boards	41.07°C/W	TBD	TBD



3. Calculations and Equations.

The purpose of this section is to derive the power dissipated into the load.

LVPECL output driver circuit and termination are shown in Figure 6.

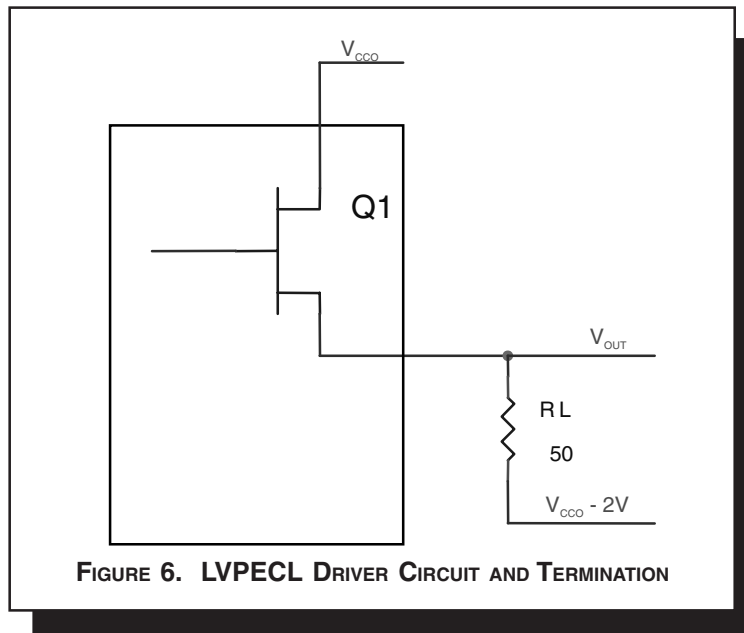

**FIGURE 6. LVPECL DRIVER CIRCUIT AND TERMINATION**

To calculate worst case power dissipation into the load, use the following equations which assume a 50Ω load, and a termination voltage of  $V_{CCO} - 2V$ .

- For logic high,  $V_{OUT} = V_{OH\_MAX} = V_{CCO\_MAX} - 0.9V$

$$(V_{CCO\_MAX} - V_{OH\_MAX}) = 0.9V$$

- For logic low,  $V_{OUT} = V_{OL\_MAX} = V_{CCO\_MAX} - 1.7V$

$$(V_{CCO\_MAX} - V_{OL\_MAX}) = 1.7V$$

Pd\_H is power dissipation when the output drives high.  
Pd\_L is the power dissipation when the output drives low.

$$Pd\_H = [(V_{OH\_MAX} - (V_{CCO\_MAX} - 2V))/R_L] * (V_{CCO\_MAX} - V_{OH\_MAX}) = [(2V - (V_{CCO\_MAX} - V_{OH\_MAX}))/R_L] * (V_{CCO\_MAX} - V_{OH\_MAX}) = [(2V - 0.9V)/50\Omega] * 0.9V = 19.8mW$$

$$Pd\_L = [(V_{OL\_MAX} - (V_{CCO\_MAX} - 2V))/R_L] * (V_{CCO\_MAX} - V_{OL\_MAX}) = [(2V - (V_{CCO\_MAX} - V_{OL\_MAX}))/R_L] * (V_{CCO\_MAX} - V_{OL\_MAX}) = [(2V - 1.7V)/50\Omega] * 1.7V = 10.2mW$$

Total Power Dissipation per output pair = Pd\_H + Pd\_L = **30mW**



Integrated  
Circuit  
Systems, Inc.

**PRELIMINARY**

**ICS8432-51K**  
700MHz, CRYSTAL-TO-3.3V DIFFERENTIAL  
LVPECL FREQUENCY SYNTHESIZER

**RELIABILITY INFORMATION**

**TABLE 11.  $\theta_{JA}$  VS. AIR FLOW TABLE FOR 32 LEAD K PACKAGE**

$\theta_{JA}$ by Velocity (Linear Feet per Minute)			
	0	200	500
Multi-Layer PCB, JEDEC Standard Test Boards	41.07C/W	TBD	TBD

**TRANSISTOR COUNT**

The transistor count for ICS8432-51K is: TBD



**PACKAGE OUTLINE - 32 LEAD K PACKAGE**

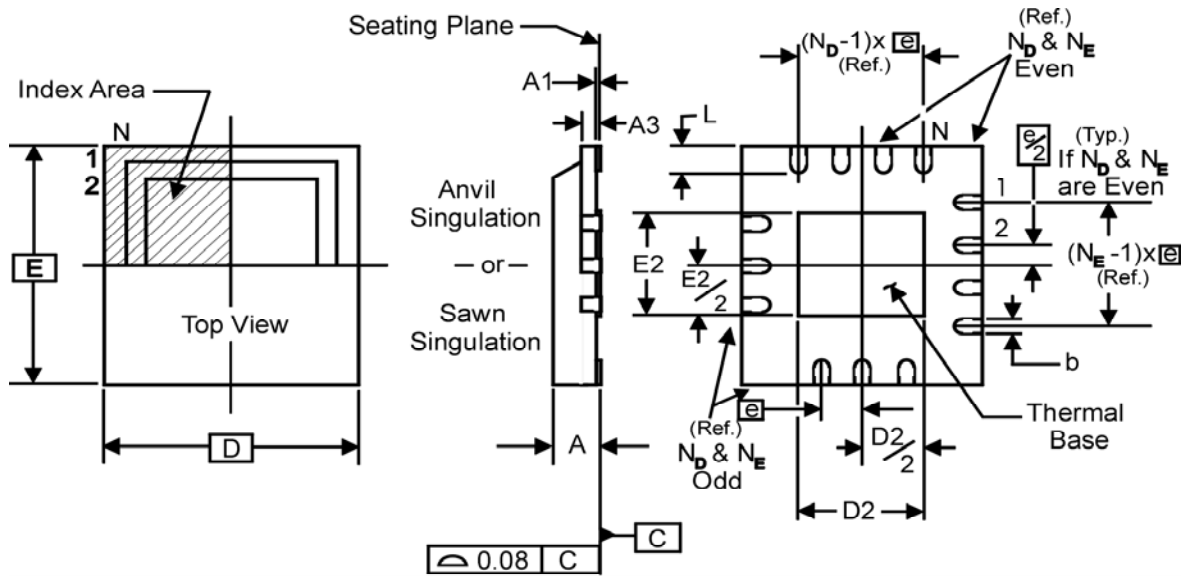

**TABLE 12. PACKAGE DIMENSIONS**

JEDEC VARIATION ALL DIMENSIONS IN MILLIMETERS		
SYMBOL	Minimum	Maximum
N	32	
A	0.80	1.0
A1	0	0.05
A3	0.25 Reference	
b	0.18	0.30
e	0.50 BASIC	
$N_D$	8	
$N_E$	8	
D	5.0	
D2	1.25	3.25
E	5.0	
E2	1.25	3.25
L	0.30	0.50

Reference Document: JEDEC Publication 95, MO-220





Integrated  
Circuit  
Systems, Inc.

**PRELIMINARY**

**ICS8432-51K**  
700MHz, CRYSTAL-TO-3.3V DIFFERENTIAL  
LVPECL FREQUENCY SYNTHESIZER

**TABLE 13. ORDERING INFORMATION**

Part/Order Number	Marking	Package	Count	Temperature
ICS8432BK-51	ICS8432BK-51	32 Lead VFQFN	60 per tube 490 per tray	0°C to 70°C
ICS8432BK-51T	ICS8432BK-51	32 Lead VFQFN on Tape and Reel	2500	0°C to 70°C

While the information presented herein has been checked for both accuracy and reliability, Integrated Circuit Systems, Incorporated (ICS) assumes no responsibility for either its use or for infringement of any patents or other rights of third parties, which would result from its use. No other circuits, patents, or licenses are implied. This product is intended for use in normal commercial applications. Any other applications such as those requiring extended temperature range, high reliability, or other extraordinary environmental requirements are not recommended without additional processing by ICS. ICS reserves the right to change any circuitry or specifications without notice. ICS does not authorize or warrant any ICS product for use in life support devices or critical medical instruments.