

### General Description

The ICS853S54I is a dual 2:1 and 1:2 Multiplexer. The 2:1 Multiplexer allows one of 2 inputs to be selected onto one output pin and the 1:2 MUX switches one input to one of two outputs. This device is useful for multiplexing multi-rate Ethernet PHYs which have 100 M bit and 1000 bit transmit/receive pairs onto an optical SFP module which has a single transmit/receive pair. See Application Section for further information.

The ICS853S54I is optimized for applications requiring very high performance and has a maximum operating frequency of 2.5GHz. The device is packaged in a small, 3mm x 3mm VFQFN package, making it ideal for use on space-constrained boards.

### Features

- Three differential LVPECL output pairs
- Three differential LVPECL clock inputs
- PCLKx/nPCLKx pairs can accept the following differential input levels: LVPECL, LVDS, CML
- Maximum output frequency: 2.5GHz
- Part-to-part skew: 200ps (maximum)
- Propagation delay: QA, nQA: 450ps (maximum)  
QBx, nQBx: 420ps (maximum)
- LVPECL mode operating voltage supply range:  $V_{CC} = 2.375V$  to  $3.465V$ ,  $V_{EE} = 0V$
- ECL mode operating voltage supply range:  $V_{CC} = 0V$ ,  $V_{EE} = -3.465V$  to  $-2.375V$
- $-40^{\circ}C$  to  $85^{\circ}C$  ambient operating temperature
- Available in lead-free (RoHS 6) packaging

### Block Diagram

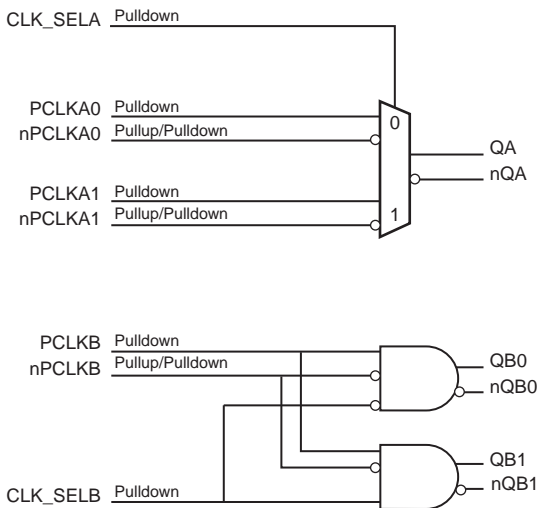

### Pin Assignment

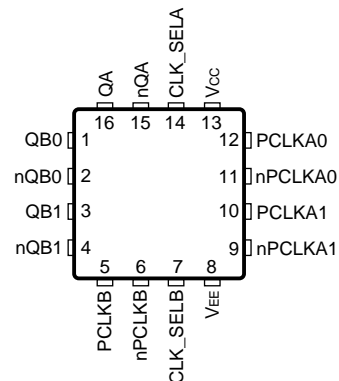

### ICS853S54I

16-Lead VFQFN  
Top View

**Table 1. Pin Descriptions**

Number	Name	Type		Description
1, 2	QB0, nQB0	Output		Differential output pair. LVPECL/ECL interface levels.
3, 4	QB1, nQB1	Output		Differential output pair. LVPECL/ECL interface levels.
5	PCLKB	Input	Pulldown	Non-inverting LVPECL/ECL differential clock input.
6	nPCLKB	Input	Pullup/ Pulldown	Inverting differential LVPECL clock input. $V_{CC}/2$ default when left floating.
7	CLK_SELB	Input	Pulldown	Clock select pin for QBx outputs. When HIGH, selects QB1/nQB1 outputs. When LOW, selects QB0/nQB0 outputs. LVCMOS/LVTTL interface levels.
8	$V_{EE}$	Power		Negative supply pin.
9	nPCLKA1	Input	Pullup/ Pulldown	Inverting differential LVPECL clock input. $V_{CC}/2$ default when left floating.
10	PCLKA1	Input	Pulldown	Non-inverting LVPECL/ECL differential clock input.
11	nPCLKA0	Input	Pullup/ Pulldown	Inverting differential LVPECL clock input. $V_{CC}/2$ default when left floating.
12	PCLKA0	Input	Pulldown	Non-inverting LVPECL/ECL differential clock input.
13	$V_{CC}$	Power		Positive supply pin.
14	CLK_SELA	Input	Pulldown	Clock select pin for QA output. When HIGH, selects QA output. When LOW, selects nQA output. LVCMOS/LVTTL interface levels.
15, 16	nQA, QA	Output		Differential output pair. LVPECL/ECL interface levels.

NOTE: Pullup and Pulldown refer to internal input resistors. See Table 2, *Pin Characteristics*, for typical values.

**Table 2. Pin Characteristics**

Symbol	Parameter	Test Conditions	Minimum	Typical	Maximum	Units
$C_{IN}$	Input Capacitance			2		pF
$R_{PULLDOWN}$	Input Pullup Resistor			37.5		k $\Omega$
$R_{VCC/2}$	RPullup/Pulldown Resistor			37.5		k $\Omega$

**Function Tables****Table 3A. Control Input Function Table, (Bank A)**

Bank A	
Control Input	Outputs
<b>CLK_SELA</b>	<b>QA, nQA</b>
0 (default)	Selects PCLKA0, nPCLKA0
1	Selects PCLKA1, nPCLKA1

**Table 3B. Control Input Function Table, (Bank B)**

Bank B		
Control Input	Outputs	
<b>CLK_SELB</b>	<b>QB0, nQB0</b>	<b>QB1, nQB1</b>
0 (default)	Follows PCLKB input	Logic Low
1	Logic Low	Follows PCLKB input

## Absolute Maximum Ratings

NOTE: Stresses beyond those listed under *Absolute Maximum Ratings* may cause permanent damage to the device. These ratings are stress specifications only. Functional operation of product at these conditions or any conditions beyond those listed in the *DC Characteristics* or *AC Characteristics* is not implied. Exposure to absolute maximum rating conditions for extended periods may affect product reliability.

Item	Rating
Supply Voltage, $V_{CC}$	4.6V (LVPECL mode, $V_{EE} = 0V$ )
Negative Supply Voltage, $V_{EE}$	-4.6V (ECL mode, $V_{CC} = 0V$ )
Inputs, $V_I$ (LVPECL mode)	-0.5V to $V_{CC} + 0.5V$
Inputs, $V_I$ (ECL mode)	0.5V to $V_{EE} - 0.5V$
Outputs, $I_O$ Continuous Current Surge Current	50mA 100mA
Operating Temperature Range, $T_A$	-40°C to 85°C
Storage Temperature, $T_{STG}$	-65°C to 150°C
Package Thermal Impedance, $\theta_{JA}$	74.7°C/W (0 mps)

## DC Electrical Characteristics

**Table 4A. Power Supply DC Characteristics,  $V_{CC} = 2.375V$  to  $3.465V$ ,  $V_{EE} = 0V$ ,  $T_A = -40^\circ C$  to  $85^\circ C$**

Symbol	Parameter	Test Conditions	Minimum	Typical	Maximum	Units
$V_{CC}$	Positive Supply Voltage		3.135	3.3	3.465	V
			2.375	2.5	2.625	V
$I_{EE}$	Power Supply Current				45	mA

**Table 4B. LVCMOS/LVTTL DC Characteristics,  $V_{CC} = 2.375V$  to  $3.465V$ ,  $V_{EE} = 0V$ ,  $T_A = -40^\circ C$  to  $85^\circ C$**

Symbol	Parameter	Test Conditions	Minimum	Typical	Maximum	Units
$V_{IH}$	Input High Voltage		$0.7V_{CC}$		$V_{CC} + 0.3$	V
$V_{IL}$	Input Low Voltage		-0.3		$0.3V_{CC}$	V
$I_{IH}$	Input High Current	CLK_SELA, CLK_SELB $V_{CC} = V_{IN}$			150	$\mu A$
$I_{IL}$	Input Low Current	CLK_SELA, CLK_SELB $V_{CC} = V_{IN}$			-150	$\mu A$

**Table 4C. LVCMOS/LVTTL DC Characteristics,  $V_{CC} = 0V$ ,  $V_{EE} = -3.465V$  to  $-2.375V$ ,  $T_A = -40^\circ C$  to  $85^\circ C$**

Symbol	Parameter	Test Conditions	Minimum	Typical	Maximum	Units
$V_{IH}$	Input High Voltage		$0.3V_{EE}$		0.3	V
$V_{IL}$	Input Low Voltage		$V_{EE} - 0.3$		$0.7V_{EE}$	V
$I_{IH}$	Input High Current	CLK_SELA, CLK_SELB $V_{CC} = V_{IN}$			150	$\mu A$
$I_{IL}$	Input Low Current	CLK_SELA, CLK_SELB $V_{CC} = V_{IN}$			-150	$\mu A$

**Table 4D. LVPECL DC Characteristics,  $V_{CC} = 2.375V$  to  $3.465V$ ,  $V_{EE} = 0V$ ,  $T_A = -40^{\circ}C$  to  $85^{\circ}C$** 

Symbol	Parameter	Test Conditions	Minimum	Typical	Maximum	Units
$I_{IH}$	Input High Current	PCLKA[0:1], PCLKB	$V_{CC} = V_{IN}$		200	$\mu A$
		nPCLKA[0:1], nPCLKB	$V_{CC} = V_{IN}$		200	$\mu A$
$I_{IL}$	Input Low Current	PCLKA[0:1], PCLKB	$V_{CC} = 3.465V$ , $V_{IN} = 0V$	-200		$\mu A$
		nPCLKA[0:1], nPCLKB	$V_{CC} = 3.465V$ , $V_{IN} = 0V$	-200		$\mu A$
$V_{PP}$	Peak-to-Peak Input Voltage; NOTE 1		0.15		1.2	V
$V_{CMR}$	Common Mode Input Voltage; NOTE 1, 2		1.2		$V_{CC}$	V
$V_{OH}$	Output High Current; NOTE 3		$V_{CC} - 1.125$	$V_{CC} - 1.005$	$V_{CC} - 0.875$	V
$V_{OL}$	Output Low Current; NOTE 3		$V_{CC} - 1.895$	$V_{CC} - 1.78$	$V_{CC} - 1.62$	V
$V_{SWING}$	Peak-to-Peak Output Voltage Swing		0.6		1.0	V

NOTE 1:  $V_{IL}$  should not be less than  $-0.3V$ .

NOTE 2: Common mode input voltage is defined as  $V_{IH}$ .

NOTE 3: Outputs terminated with  $50\Omega$  to  $V_{CC} - 2V$ .

## AC Electrical Characteristics

**Table 5. AC Characteristics,  $V_{CC} = 2.375V$  to  $3.465V$ ,  $V_{EE} = 0V$  or  $V_{CC} = 0V$ ,  $V_{EE} = -3.465V$  to  $-2.375V$ ,  $T_A = -40^{\circ}C$  to  $85^{\circ}C$** 

Symbol	Parameter	Test Conditions	Minimum	Typical	Maximum	Units
$f_{OUT}$	Output Frequency				2.5	GHz
$t_{PD}$	Propagation Delay; NOTE 1	QA, nQA	225	335	445	ps
		QBx, nQBx	195	305	420	ps
$t_{sk(pp)}$	Part-to-Part Skew; NOTE 2, 3				200	ps
$t_{jit}$	Buffer Additive Phase Jitter, RMS; refer to Additive Phase Jitter Section; NOTE 4	622.08MHz Integration Range: 12kHz - 20MHz		0.035		ps
MUX_ISOLATION	MUX Isolation; NOTE 5	$f_{OUT} = 622.08MHz$ , $V_{PP} = 800mV$		65		dB
$t_R / t_F$	Output Rise/Fall Time	20% to 80%	75	155	250	ps

NOTE: Electrical parameters are guaranteed over the specified ambient operating temperature range, which is established when the device is mounted in a test socket with maintained transverse airflow greater than 500 lfpm. The device will meet specifications after thermal equilibrium has been reached under these conditions.

NOTE: All parameters are measured  $\leq 1GHz$  unless otherwise noted.

NOTE 1: Measured from the differential input crossing point to the differential output crossing point.

NOTE 2: Defined as skew between outputs on different devices operating at the same supply voltage, same temperature, same frequency and with equal load conditions. Using the same type of inputs on each device, the outputs are measured at the differential cross points.

NOTE 3: This parameter is defined in accordance with JEDEC Standard 65.

NOTE 4: Measured using clock input at 622.08MHz.

NOTE 5: Q/nQ output measured differentially. See *Parameter Measurement Information* for MUX Isolation diagram.

## Additive Phase Jitter

The spectral purity in a band at a specific offset from the fundamental compared to the power of the fundamental is called the **dBc Phase Noise**. This value is normally expressed using a Phase noise plot and is most often the specified plot in many applications. Phase noise is defined as the ratio of the noise power present in a 1Hz band at a specified offset from the fundamental frequency to the power value of the fundamental. This ratio is expressed in decibels (dBm)

or a ratio of the power in the 1Hz band to the power in the fundamental. When the required offset is specified, the phase noise is called a **dBc** value, which simply means dBm at a specified offset from the fundamental. By investigating jitter in the frequency domain, we get a better understanding of its effects on the desired application over the entire time record of the signal. It is mathematically possible to calculate an expected bit error rate given a phase noise plot.

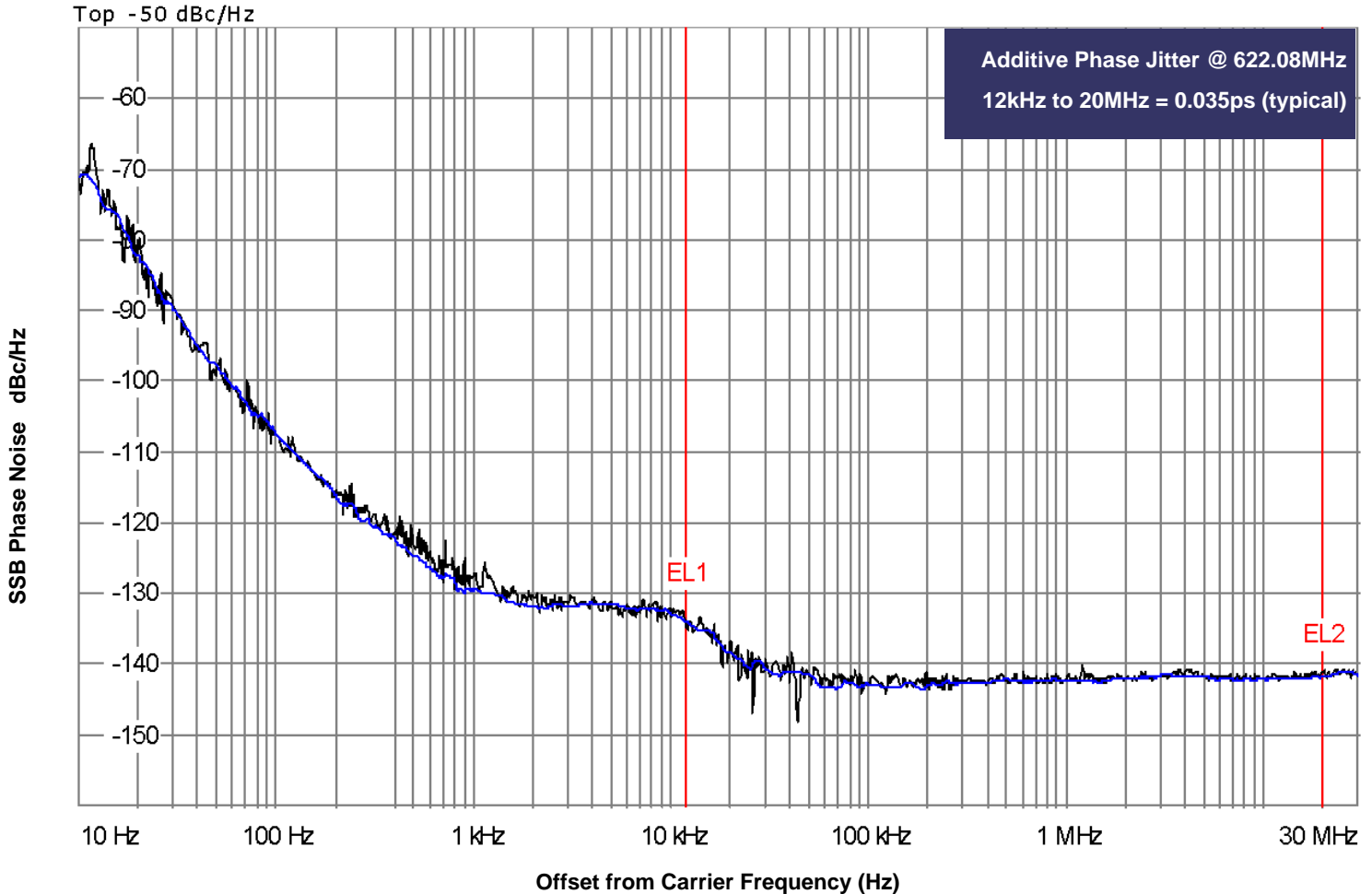

As with most timing specifications, phase noise measurements has issues relating to the limitations of the equipment. Often the noise floor of the equipment is higher than the noise floor of the device. This is illustrated above. The device meets the noise floor of what is shown, but can actually be lower. The phase noise is dependent on the input source and measurement equipment.

The source generator “IFR2042 10kHz – 56.4GHz Low Noise Signal Generator as external input to an Agilent 8133A 3GHz Pulse Generator”.

### Parameter Measurement Information

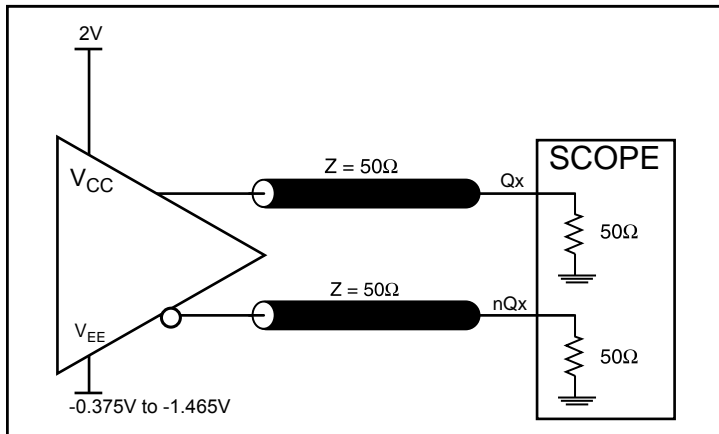

LVPECL Output Load AC Test Circuit

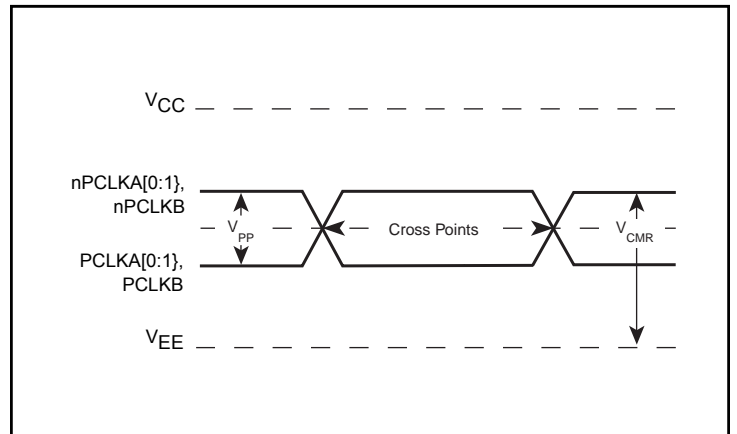

Differential Input Level

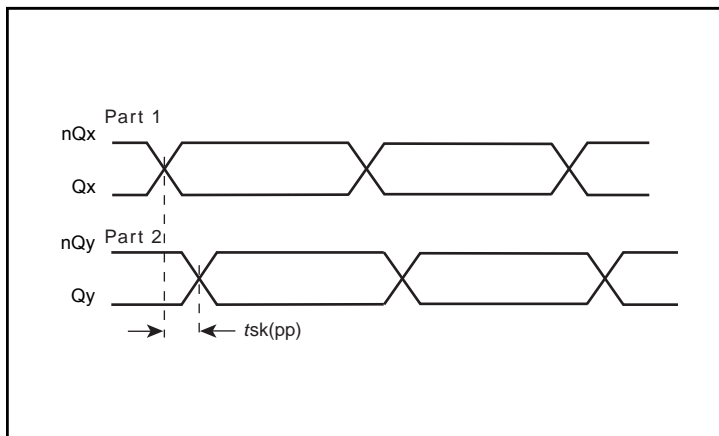

Part-to-Part Skew

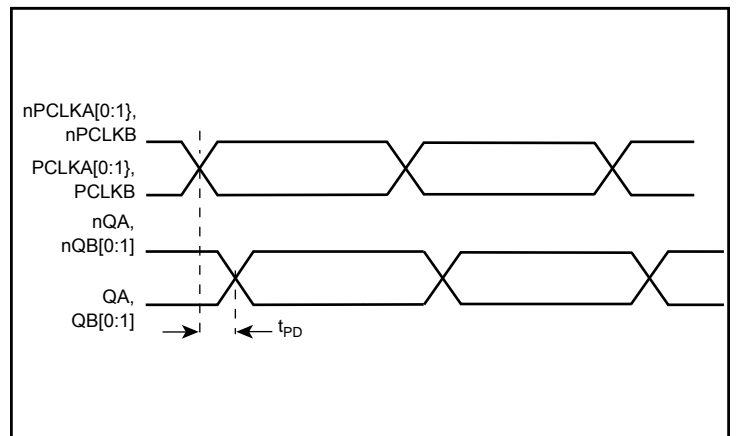

Propagation Delay

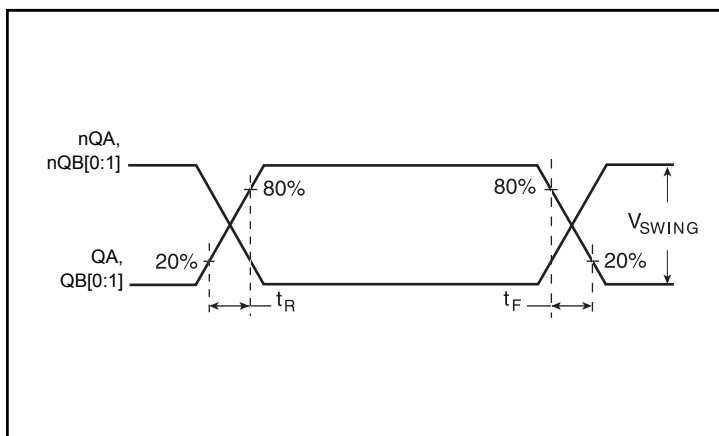

Output Rise/Fall Time

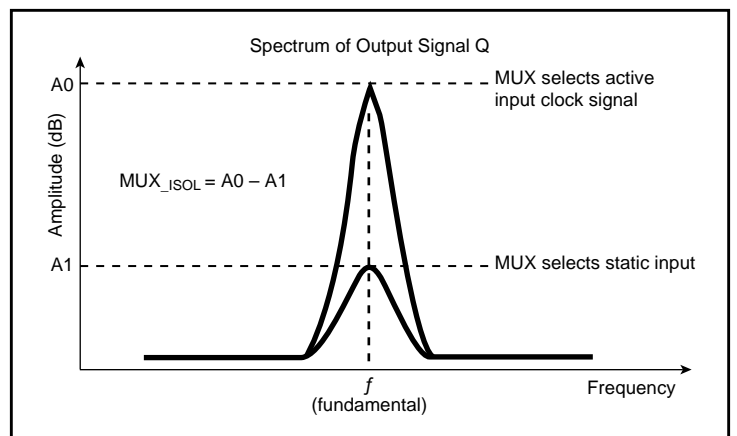

MUX Isolation

## Application Information

### Wiring the Differential Input to Accept Single Ended Levels

Figure 1 shows how the differential input can be wired to accept single ended levels. The reference voltage  $V_{REF} = V_{CC}/2$  is generated by the bias resistors R1, R2 and C1. This bias circuit should be located as close as possible to the input pin. The ratio of R1 and R2 might need to be adjusted to position the  $V_{REF}$  in the center of the input voltage swing. For example, if the input clock swing is only 2.5V and  $V_{CC} = 3.3V$ ,  $V_{REF}$  should be 1.25V and  $R2/R1 = 0.609$ .

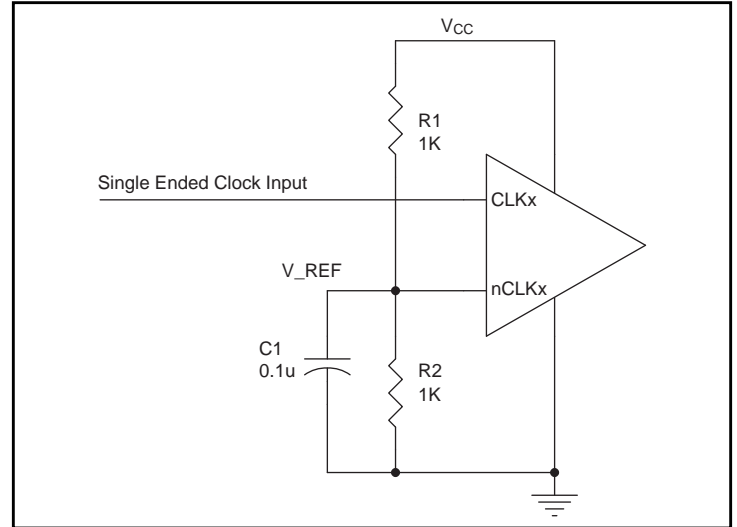

Figure 1. Single-Ended Signal Driving Differential Input

## Recommendations for Unused Input and Output Pins

### Inputs:

#### LVC MOS Control Pins

All control pins have internal pulldowns; additional resistance is not required but can be added for additional protection. A 1k $\Omega$  resistor can be used.

#### PCLK/nPCLK Inputs

For applications not requiring the use of the differential input, both PCLK and nPCLK can be left floating. Though not required, but for additional protection, a 1k $\Omega$  resistor can be tied from PCLK to ground.

### Outputs:

#### LVPECL Outputs

All unused LVPECL outputs can be left floating. We recommend that there is no trace attached. Both sides of the differential output pair should either be left floating or terminated.

### LVPECL Differential Clock Input Interface (3.3V)

The PCLK /nPCLK accepts LVDS, LVPECL, and other differential signals. Both  $V_{SWING}$  and  $V_{OH}$  must meet the  $V_{PP}$  and  $V_{CMR}$  input requirements. Figures 2A to 2C show interface examples for the PCLK/nPCLK input driven by the most common driver types. The

input interfaces suggested here are examples only. If the driver is from another vendor, use their termination recommendation. Please consult with the vendor of the driver component to confirm the driver termination requirements.

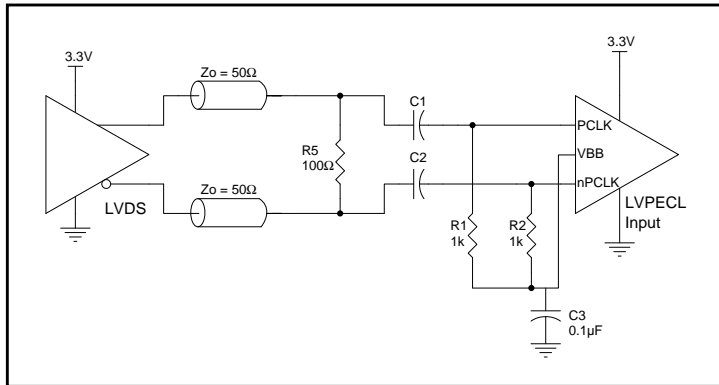

Figure 2A. PCLK/nPCLK Input Driven by a 3.3V LVDS Driver

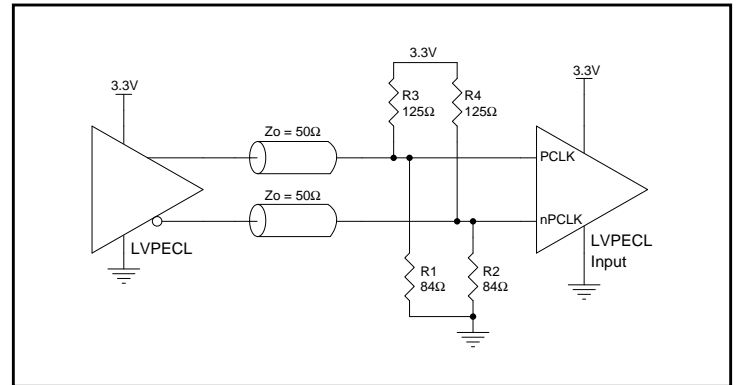

Figure 2B. PCLK/nPCLK Input Driven by a 3.3V LVPECL Driver

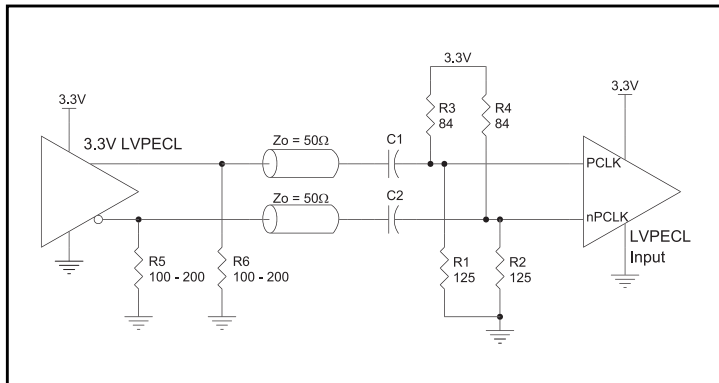

Figure 2C. PCLK/nPCLK Input Driven by a 3.3V LVPECL Driver with AC Couple

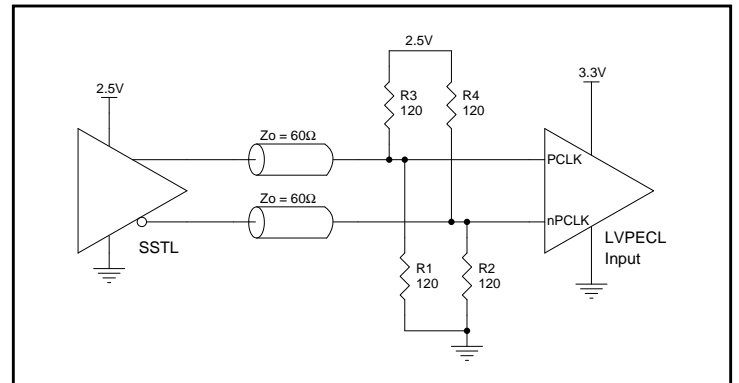

Figure 2D. PCLK/nPCLK Input Driven by an SSTL Driver

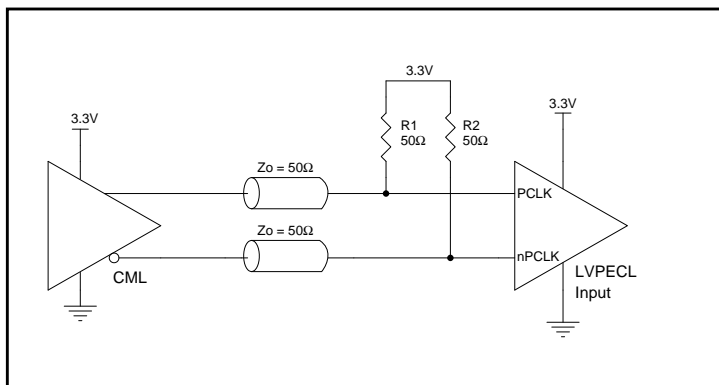

Figure 2E. PCLK/nPCLK Input Driven by a CML Driver

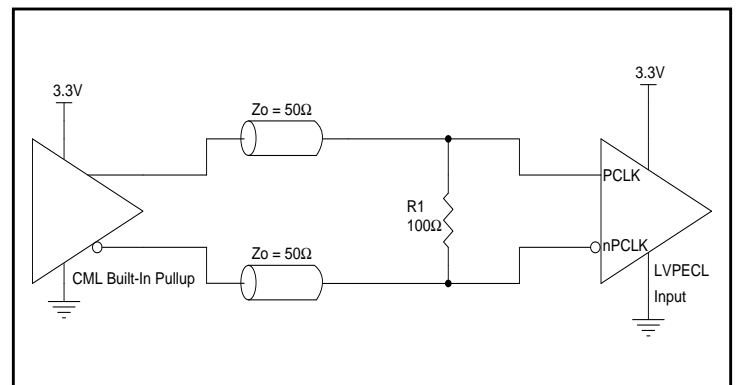

Figure 2F. PCLK/nPCLK Input Driven by a Built-In Pullup CML Driver



### LVPECL Clock Input Interface (2.5V)

The PCLK /nPCLK accepts LVPECL, LVDS and other differential signals. The differential signal must meet the  $V_{PP}$  and  $V_{CMR}$  input requirements. *Figures 2A to 2C* show interface examples for the PCLK/nPCLK input driven by the most common driver types. The

input interfaces suggested here are examples only. If the driver is from another vendor, use their termination recommendation. Please consult with the vendor of the driver component to confirm the driver termination requirements.

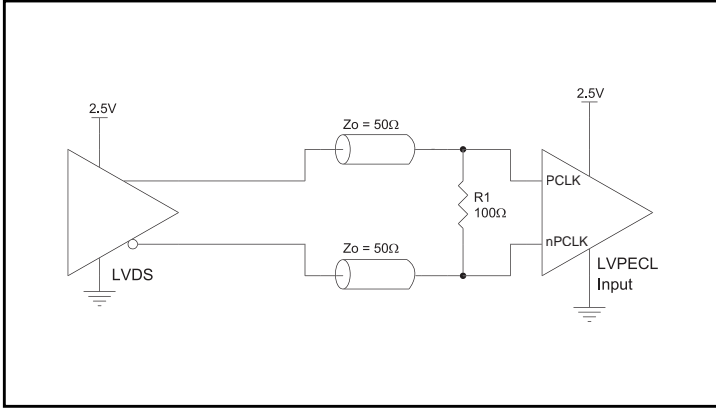

**Figure 2A. PCLK/nPCLK Input Driven by a 2.5V LVDS Driver**

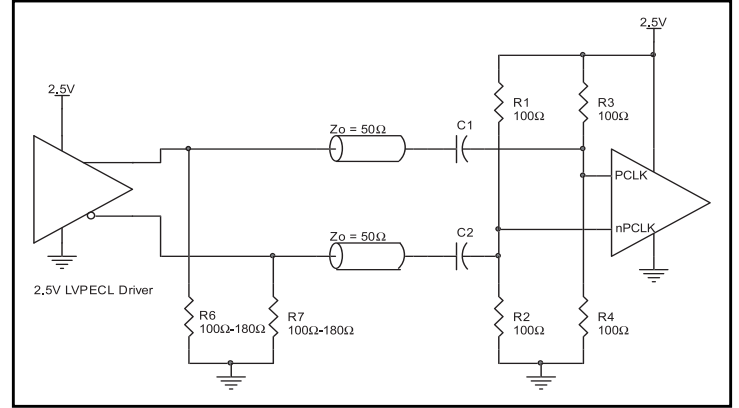

**Figure 2B. PCLK/nPCLK Input Driven by a 3.3V LVPECL Driver with AC Couple**

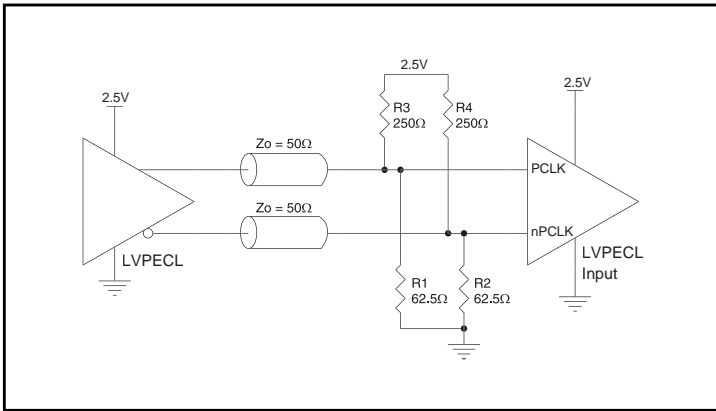

**Figure 2C. PCLK/nPCLK Input Driven by a 2.5V LVPECL Driver**

## VFQFN EPAD Thermal Release Path

In order to maximize both the removal of heat from the package and the electrical performance, a land pattern must be incorporated on the Printed Circuit Board (PCB) within the footprint of the package corresponding to the exposed metal pad or exposed heat slug on the package, as shown in *Figure 4*. The solderable area on the PCB, as defined by the solder mask, should be at least the same size/shape as the exposed pad/slug area on the package to maximize the thermal/electrical performance. Sufficient clearance should be designed on the PCB between the outer edges of the land pattern and the inner edges of pad pattern for the leads to avoid any shorts.

While the land pattern on the PCB provides a means of heat transfer and electrical grounding from the package to the board through a solder joint, thermal vias are necessary to effectively conduct from the surface of the PCB to the ground plane(s). The land pattern must be connected to ground through these vias. The vias act as “heat pipes”. The number of vias (i.e. “heat pipes”) are application specific

and dependent upon the package power dissipation as well as electrical conductivity requirements. Thus, thermal and electrical analysis and/or testing are recommended to determine the minimum number needed. Maximum thermal and electrical performance is achieved when an array of vias is incorporated in the land pattern. It is recommended to use as many vias connected to ground as possible. It is also recommended that the via diameter should be 12 to 13mils (0.30 to 0.33mm) with 1oz copper via barrel plating. This is desirable to avoid any solder wicking inside the via during the soldering process which may result in voids in solder between the exposed pad/slug and the thermal land. Precautions should be taken to eliminate any solder voids between the exposed heat slug and the land pattern. Note: These recommendations are to be used as a guideline only. For further information, please refer to the Application Note on the Surface Mount Assembly of Amkor’s Thermally/Electrically Enhance Leadframe Base Package, Amkor Technology.

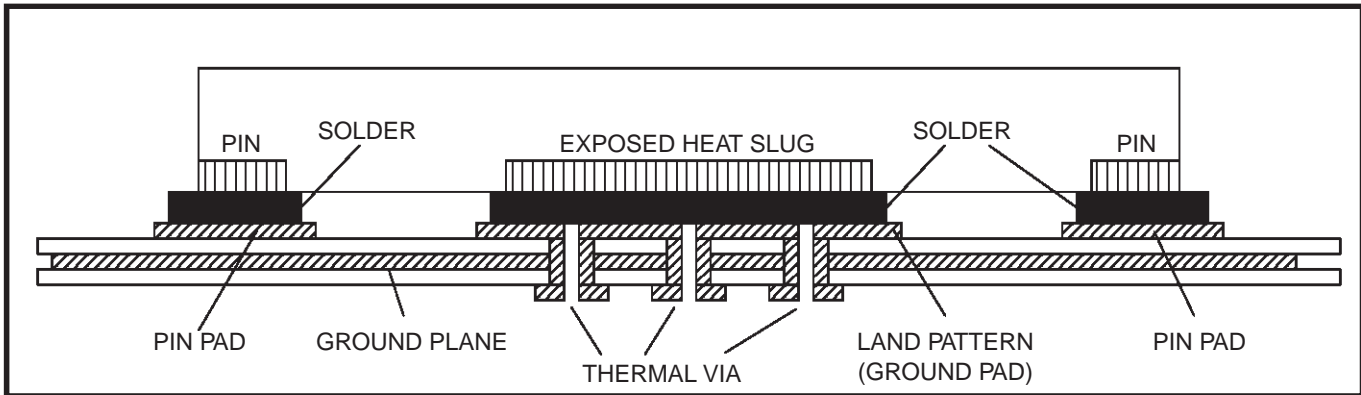

**Figure 4. P.C. Assembly for Exposed Pad Thermal Release Path – Side View (drawing not to scale)**



## Termination for 2.5V LVPECL Outputs

Figure 6A and Figure 6B show examples of termination for 2.5V LVPECL driver. These terminations are equivalent to terminating  $50\Omega$  to  $V_{CC} - 2V$ . For  $V_{CC} = 2.5V$ , the  $V_{CC} - 2V$  is very close to ground

level. The R3 in Figure 6B can be eliminated and the termination is shown in Figure 6C.

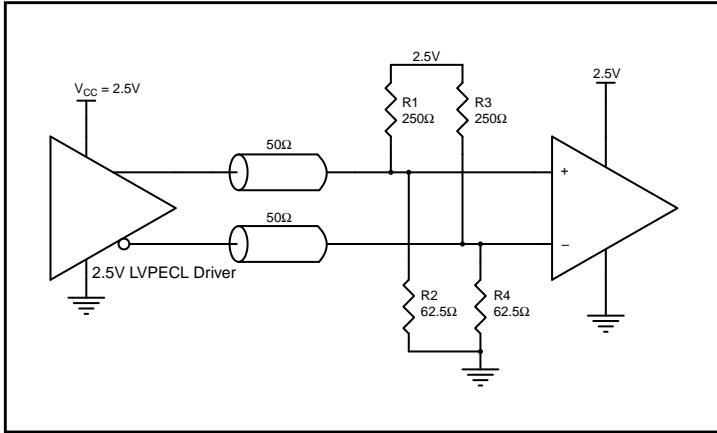

Figure 6A. 2.5V LVPECL Driver Termination Example

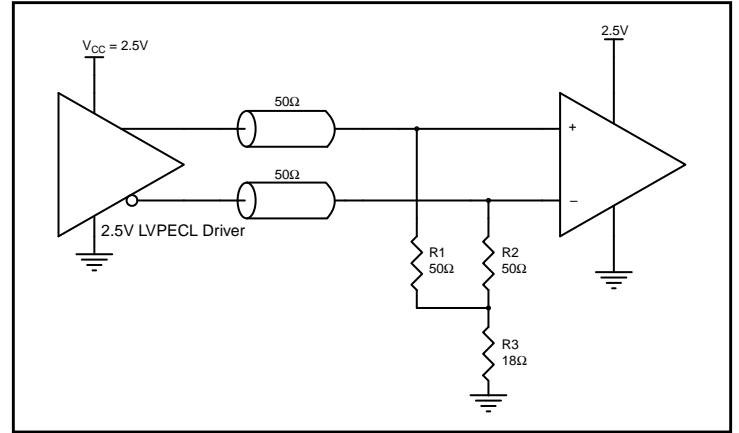

Figure 6B. 2.5V LVPECL Driver Termination Example

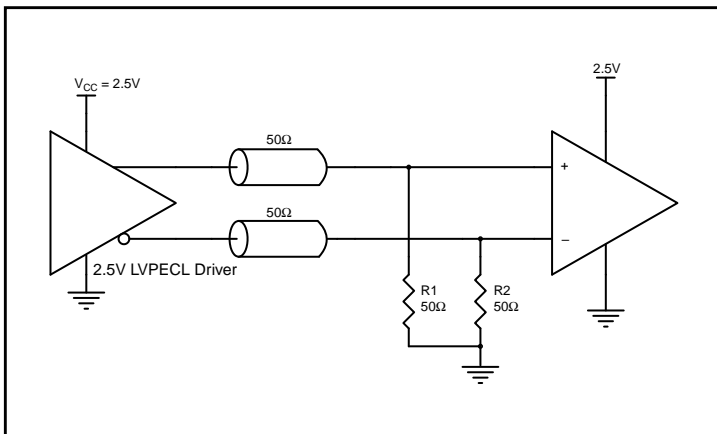
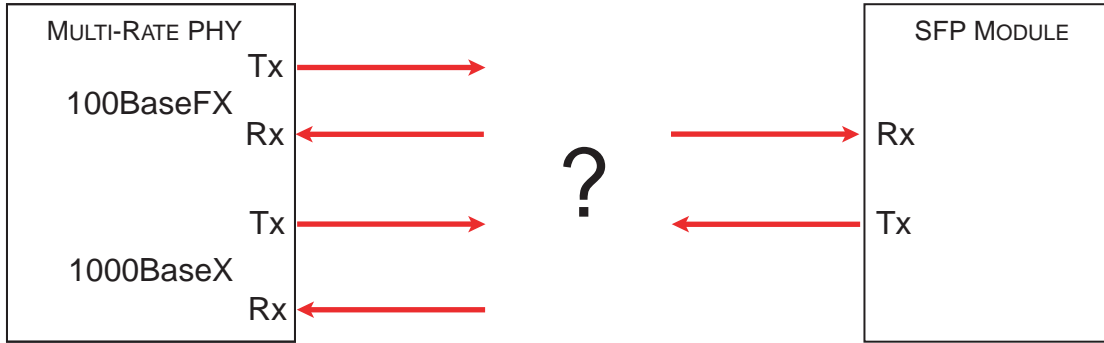

Figure 6C. 2.5V LVPECL Driver Termination Example

### A Typical Application for the ICS853S54I

Used to connect a multi-rate PHY with the Tx/Rx pins of an SFP Module.

Problem Addressed: How to map the 2 Tx/Rx pairs of the multi-rate PHY to the single Tx/Rx pair on the SFP Module.



### Mode 1, 100BaseX Connected to SFP

All lines are differential pairs, but drawn as single-ended to simplify the drawing.

Bold red lines are active connections highlighting the signal path.

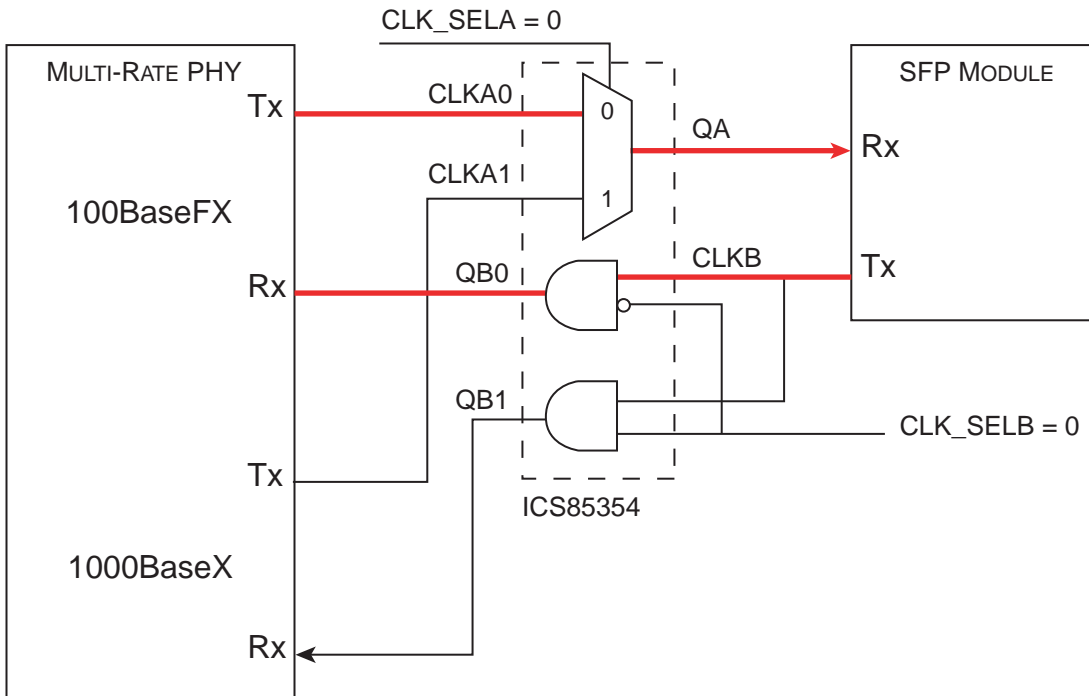

### Mode 2, 100BaseX Connected to SFP

All lines are differential pairs, but drawn as single-ended to simplify the drawing.

Bold red lines are active connections highlighting the signal path.

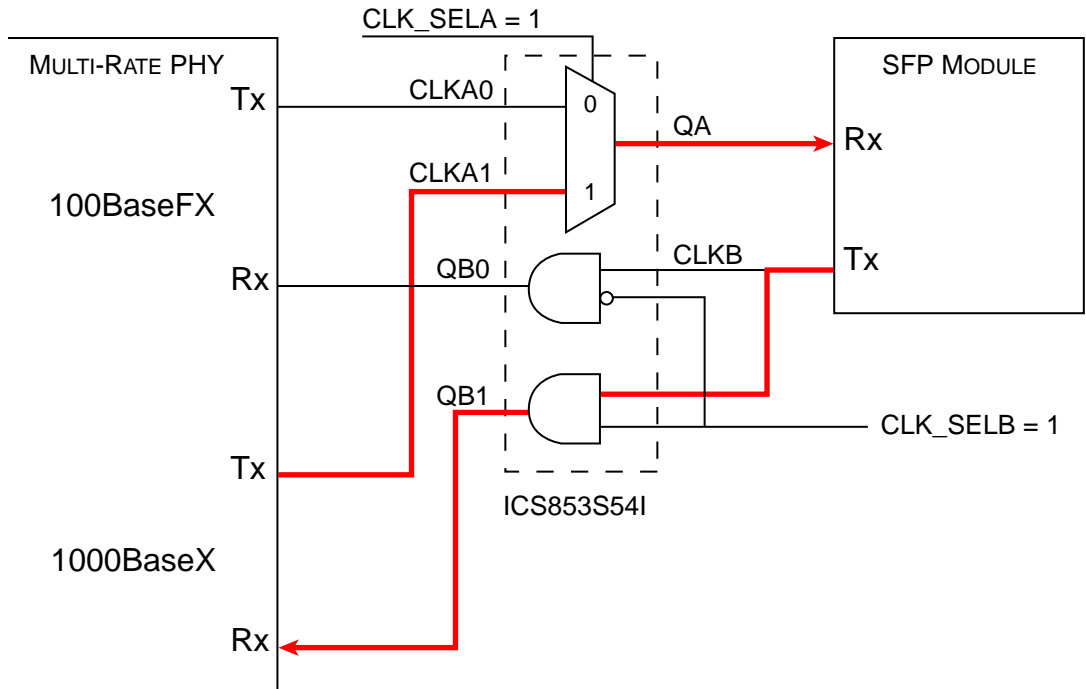

## Power Considerations

This section provides information on power dissipation and junction temperature for the ICS853S54I. Equations and example calculations are also provided.

### 1. Power Dissipation.

The total power dissipation for the ICS853S54I is the sum of the core power plus the power dissipation in the load(s). The following is the power dissipation for  $V_{CC} = 3.3V + 5\% = 3.465V$ , which gives worst case results.

NOTE: Please refer to Section 3 for details on calculating power dissipation in the load.

- Power (core)<sub>MAX</sub> =  $V_{CC\_MAX} * I_{EE\_MAX} = 3.465V * 45mA = 155.925mW$
- Power (outputs)<sub>MAX</sub> = **32mW/Loaded Output pair**  
If all outputs are loaded, the total power is  $3 * 32mW = 96mW$

**Total Power**<sub>MAX</sub> (3.3V, with all outputs switching) =  $155.925mW + 96mW = 251.925mW$

### 2. Junction Temperature.

Junction temperature,  $T_j$ , is the temperature at the junction of the bond wire and bond pad, and directly affects the reliability of the device. The maximum recommended junction temperature is 125°C. Limiting the internal transistor junction temperature,  $T_j$ , to 125°C ensures that the bond wire and bond pad temperature remains below 125°C.

The equation for  $T_j$  is as follows:  $T_j = \theta_{JA} * Pd\_total + T_A$

$T_j$  = Junction Temperature

$\theta_{JA}$  = Junction-to-Ambient Thermal Resistance

$Pd\_total$  = Total Device Power Dissipation (example calculation is in section 1 above)

$T_A$  = Ambient Temperature

In order to calculate junction temperature, the appropriate junction-to-ambient thermal resistance  $\theta_{JA}$  must be used. Assuming no air flow and a multi-layer board, the appropriate value is 74.7°C/W per Table 6 below.

Therefore,  $T_j$  for an ambient temperature of 85°C with all outputs switching is:

$$85^\circ C + 0.252W * 74.7^\circ C/W = 103.8^\circ C. \text{ This is well below the limit of } 125^\circ C.$$

This calculation is only an example.  $T_j$  will obviously vary depending on the number of loaded outputs, supply voltage, air flow and the type of board (single layer or multi-layer).

**Table 6. Thermal Resistance  $\theta_{JA}$  for 16 Lead VFQFN, Forced Convection**

$\theta_{JA}$ by Velocity			
Meters per Second	0		
Multi-Layer PCB, JEDEC Standard Test Boards	74.7°C/W	65.3°C/W	58.5°C/W

### 3. Calculations and Equations.

The purpose of this section is to calculate the power dissipation for the LVPECL output pair.

The LVPECL output driver circuit and termination are shown in *Figure 7*.

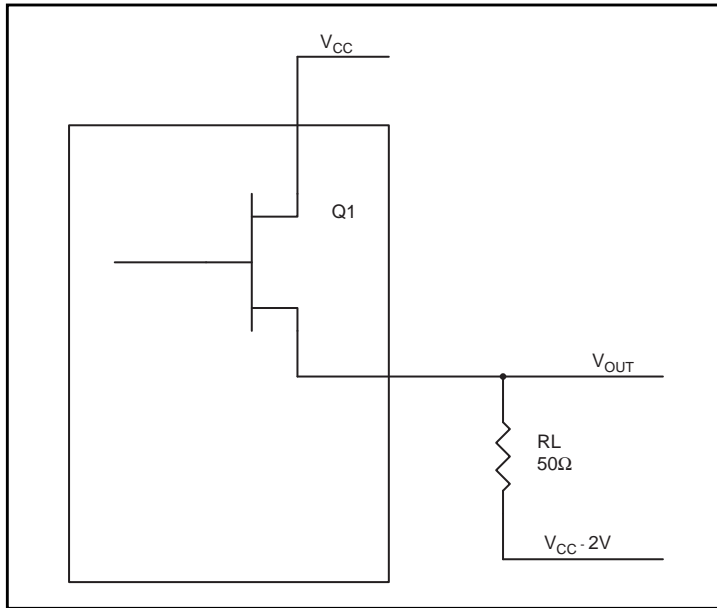

**Figure 7. LVPECL Driver Circuit and Termination**

To calculate worst case power dissipation into the load, use the following equations which assume a 50Ω load, and a termination voltage of  $V_{CC} - 2V$ .

- For logic high,  $V_{OUT} = V_{OH\_MAX} = V_{CC\_MAX} - 0.875V$   
( $V_{CC\_MAX} - V_{OH\_MAX}$ ) = **0.875V**
- For logic low,  $V_{OUT} = V_{OL\_MAX} = V_{CC\_MAX} - 1.62V$   
( $V_{CC\_MAX} - V_{OL\_MAX}$ ) = **1.62V**

$Pd\_H$  is power dissipation when the output drives high.

$Pd\_L$  is the power dissipation when the output drives low.

$$Pd\_H = [(V_{OH\_MAX} - (V_{CC\_MAX} - 2V))/R_L] * (V_{CC\_MAX} - V_{OH\_MAX}) = [(2V - (V_{CC\_MAX} - V_{OH\_MAX}))/R_L] * (V_{CC\_MAX} - V_{OH\_MAX}) = [(2V - 0.875V)/50\Omega] * 0.875V = \mathbf{19.69mW}$$

$$Pd\_L = [(V_{OL\_MAX} - (V_{CC\_MAX} - 2V))/R_L] * (V_{CC\_MAX} - V_{OL\_MAX}) = [(2V - (V_{CC\_MAX} - V_{OL\_MAX}))/R_L] * (V_{CC\_MAX} - V_{OL\_MAX}) = [(2V - 1.62V)/50\Omega] * 1.62V = \mathbf{12.31mW}$$

Total Power Dissipation per output pair =  $Pd\_H + Pd\_L = \mathbf{32mW}$



## Reliability Information

**Table 7.  $\theta_{JA}$  vs. Air Flow Table for a 16 Lead VFQFN**

$\theta_{JA}$ by Velocity			
Meters per Second	<b>0</b>		
Multi-Layer PCB, JEDEC Standard Test Boards	74.7°C/W	65.3°C/W	58.5°C/W

## Transistor Count

The transistor count for ICS853S54I is: 296

This is a suggested replacement for ICS85354

# Package Outline Drawings (Sheet 1)

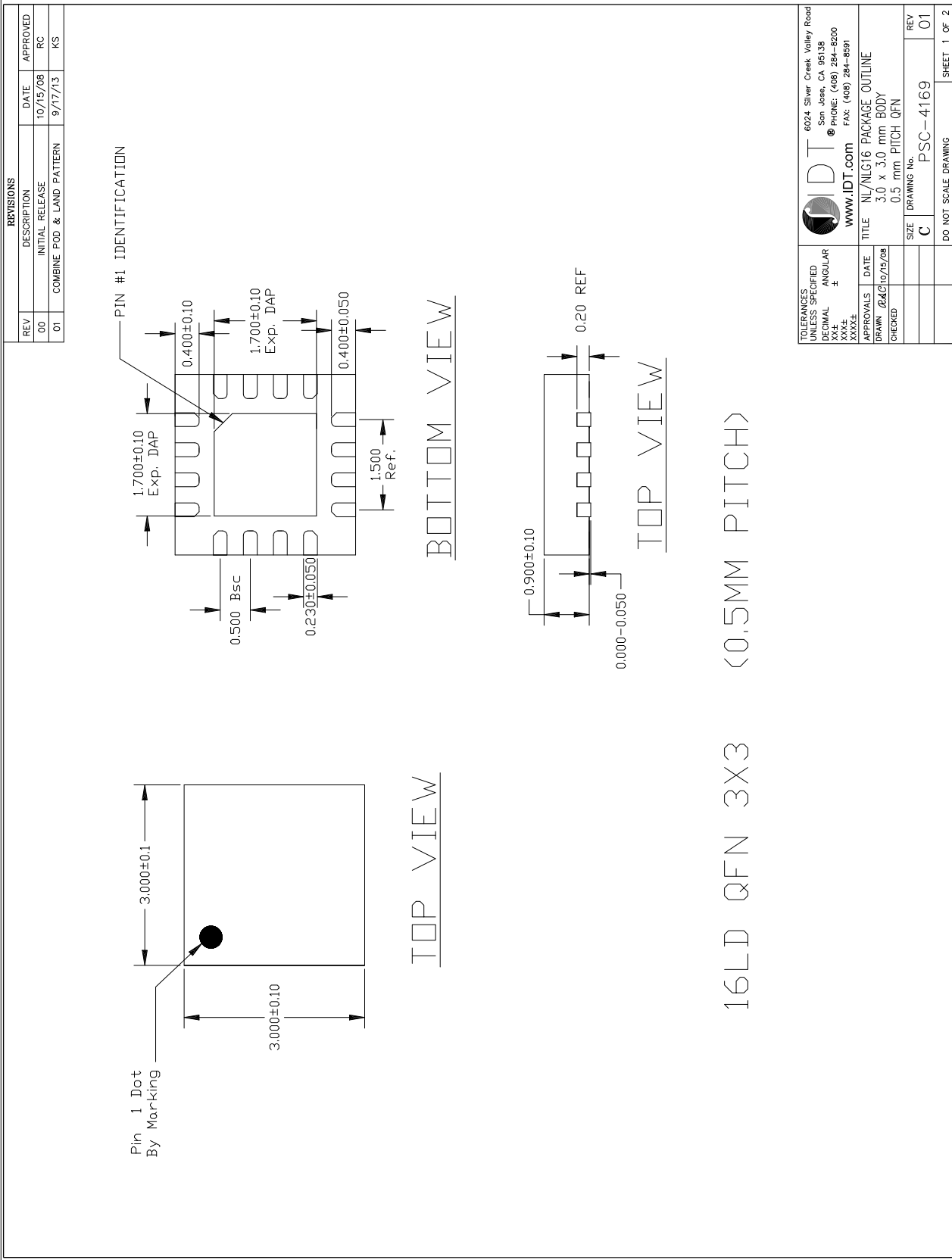

TOLERANCES UNLESS SPECIFIED	JIDT 6024 Silver Creek Valley Road San Jose, CA 95138		
DECIMAL	±	PHONE: (408) 284-8200	
XXX.		FAX: (408) 284-8591	
XXXX.		WWW.IDT.COM	
APPROVALS	DATE	TITLE	REV
DRAWN	06/10/15/08	NL/NLG16 PACKAGE OUTLINE	
CHECKED		3.0 x 3.0 mm BODY	
		0.5 mm PITCH QFN	
		SIZE	DRAWING No.
		C	PSC-4169
			DO NOT SCALE DRAWING
			SHEET 1 OF 2

# Package Outline Drawings (Sheet 2)

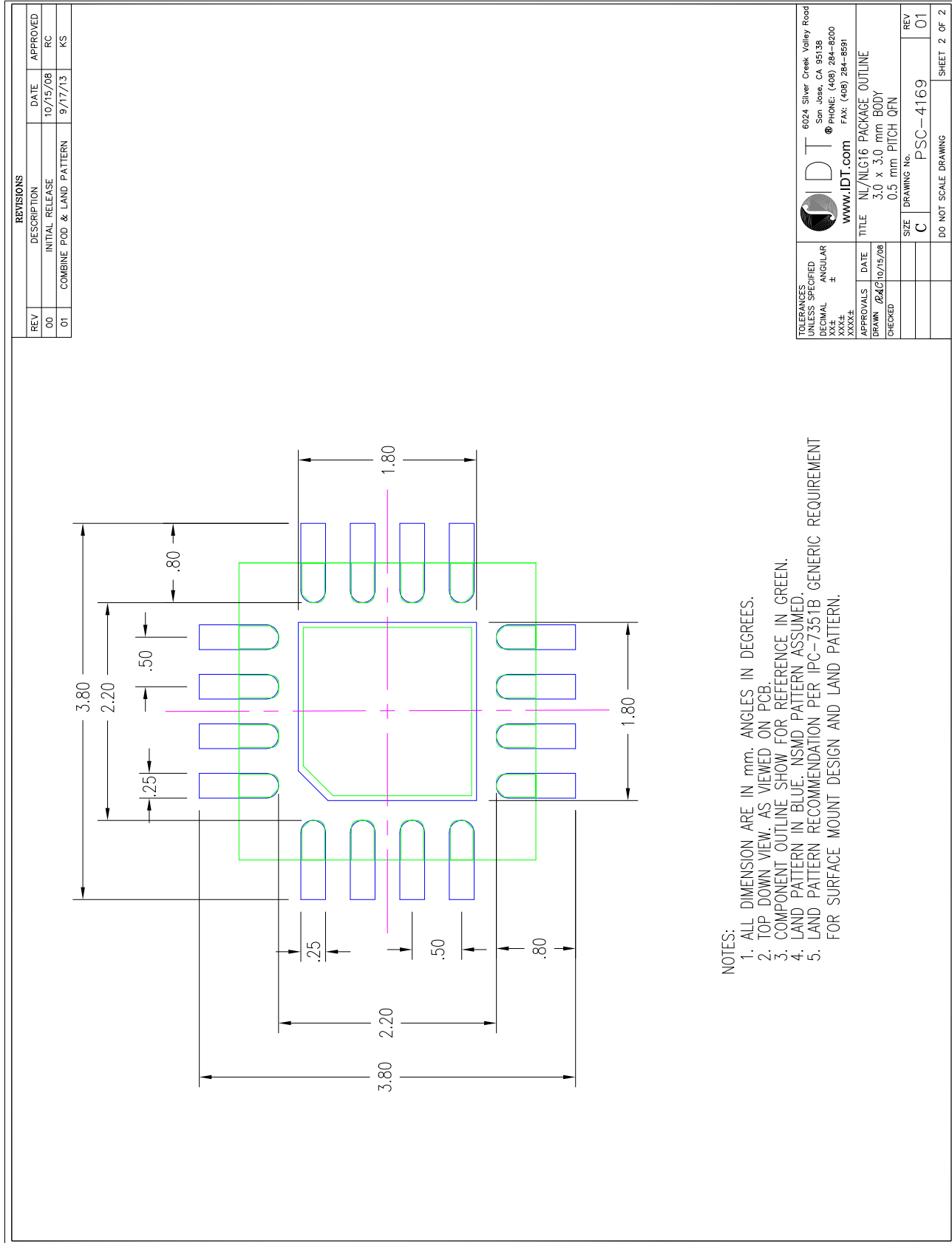

## Ordering Information

**Table 9. Ordering Information**

<b>Part/Order Number</b>	<b>Marking</b>	<b>Package</b>	<b>Shipping Packaging</b>	<b>Temperature</b>
853S54AKILF	S54A	“Lead-Free” 16 Lead VFQFN	Tube	-40°C to 85°C
853S54AKILFT	S54A	“Lead-Free” 16 Lead VFQFN	Tape & Reel	-40°C to 85°C

NOTE: Parts that are ordered with an “LF” suffix to the part number are the Pb-Free configuration and are RoHS compliant.

## Revision History Sheet

Rev	Table	Page	Description of Change	Date
A	T9	1 8 19	Deleted HiperClockS Logo. Added CML to 3rd bullet. Added figures 2D, 2E and 2F. Deleted quantity from tape and reel.	10/30/2012
B	-	18	Updated the package outline drawings.	5/27/2017



Corporate Headquarters  
6024 Silver Creek Valley Road  
San Jose, CA 95138 USA  
[www.IDT.com](http://www.IDT.com)

Sales  
1-800-345-7015 or 408-284-8200  
Fax: 408-284-2775  
[www.IDT.com/go/sales](http://www.IDT.com/go/sales)

Tech Support  
[www.IDT.com/go/support](http://www.IDT.com/go/support)

DISCLAIMER Integrated Device Technology, Inc. (IDT) and its affiliated companies (herein referred to as "IDT") reserve the right to modify the products and/or specifications described herein at any time, without notice, at IDT's sole discretion. Performance specifications and operating parameters of the described products are determined in an independent state and are not guaranteed to perform the same way when installed in customer products. The information contained herein is provided without representation or warranty of any kind, whether express or implied, including, but not limited to, the suitability of IDT's products for any particular purpose, an implied warranty of merchantability, or non-infringement of the intellectual property rights of others. This document is presented only as a guide and does not convey any license under intellectual property rights of IDT or any third parties.

IDT's products are not intended for use in applications involving extreme environmental conditions or in life support systems or similar devices where the failure or malfunction of an IDT product can be reasonably expected to significantly affect the health or safety of users. Anyone using an IDT product in such a manner does so at their own risk, absent an express, written agreement by IDT.

Integrated Device Technology, IDT and the IDT logo are trademarks or registered trademarks of IDT and its subsidiaries in the United States and other countries. Other trademarks used herein are the property of IDT or their respective third party owners. For datasheet type definitions and a glossary of common terms, visit [www.idt.com/go/glossary](http://www.idt.com/go/glossary). Integrated Device Technology, Inc.. All rights reserved.