



## Frequency Generator for Digital Video Systems

### General Description

The ICS9118-03 and ICS9118-04 are low-cost, high-performance clock generators designed to support digital video systems. 1.8MHz UART and AUDIO clocks are generated from the recovered 27MHz reference signal. The -03 supports 256x audio oversampling, and the -04 supports 384x audio oversampling.

The audio clock is synthesized from 27 MHz using a high accuracy, low jitter PLL to meet the synchronization and -96dB signal-to-noise ratios required by 16-bit DSP systems. Fast output clock edge rates minimize board-induced jitter.

### Features

- Generates AUDIO codec and UART clocks synchronized to the 27MHz recovered video clock
- Selectable AUDIO clock supports 256x and 384x over-sampling of 16.00, 22.05, 24.00, 32.00, 44.10 and 48.00 kHz
- 80ps one sigma jitter maintains 16 bit performance
- Output rise/fall times less than 1.5nS
- On chip loop filter components
- 3.0V - 5.5V supply range
- 8-pin, 150-mil SOIC package

### Pin Configuration

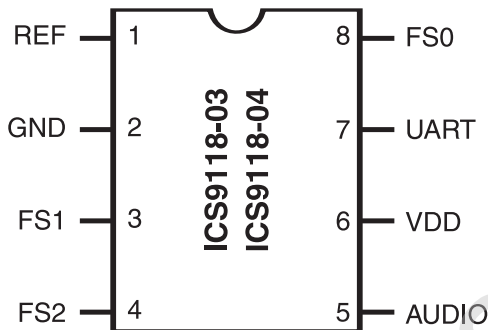

**8-Pin SOIC  
ICS9118-04 Obsolete**

### Block Diagram

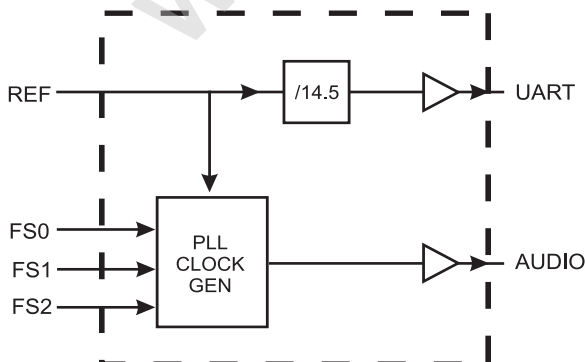

### Applications

- Specifically designed to support the high performance clocking requirements of digital video set-top and multi-media systems

### Functionality

VDD=3.0-5.5V, TEMP=0-70°

REF (MHz)	FS [2:0]	AUDIO 03 (MHz)	AUDIO 04 (MHz)	UART (MHz)
27.00	000	Tristate	Tristate	Tristate
27.00	001	256*16.00	384*16.00	1.8620
27.00	010	256*22.05	384*22.05	1.8620
27.00	011	256*24.00	384*24.00	1.8620
27.00	100	256*32.00	384*32.00	1.8620
27.00	101	256*44.10	384*44.10	1.8620
27.00	110	256*48.00	384*48.00	1.8620
27.00	111	Low	Low	Low

**ICS9118-03**  
**ICS9118-04 Obsolete**



---

**Pin Descriptions for ICS9118-01/02**

<b>PIN NUMBER</b>	<b>PIN NAME</b>	<b>TYPE</b>	<b>DESCRIPTION</b>
1	REF	IN	27.0MHz Reference input clock
2	GND	PWR	Grond for logic, output buffers
3, 4, 8	FS(0:2)	IN	Frequency multipler select pins. See Functionality table. These inputs have internal pullup devices.
5	AUDIO	OUT	Audio clock output. See Functionality table.
6	VDD	PWR	Power for logic, PCLK and fixed frequency output buffers.
7	UART	OUT	UART clock output fixed out 1.8620MHz.



## Absolute Maximum Ratings

AVDD, VDD referenced to GND .....	7V
Operating temperature under bias .....	0°C to +70°C
Storage temperature .....	-65°C to +150°C
Voltage on I/O pins referenced to GND .....	GND-0.5V to VDD+0.5V
Power dissipation .....	0.5 Watts

Stresses above those listed under Absolute Maximum Ratings may cause permanent damage to the device. This is a stress rating only and functional operation of the device at these or any other conditions above those indicated in the operational sections of the specifications is not implied. Exposure to absolute maximum rating conditions for extended periods may affect product reliability.

## Electrical Characteristics at 5V

Operation  $V_{DD} = +4.5$  to  $+5.5$  V,  $T_A = 0$  to  $70^\circ\text{C}$  unless otherwise stated

DC Characteristics						
PARAMETER	SYMBOL	TEST CONDITIONS	MIN	TYP	MAX	UNITS
Input Low Voltage	$V_{IL}$		-	-	0.8	V
Input High Voltage	$V_{IH}$		2.0	-	-	V
Input Low Current	$I_{IL}$	$V_{IN}=0V$	-	8.3	-18.0	$\mu\text{A}$
Input High Current	$I_{IH}$	$V_{IN}=V_{DD}$	-	-	5.0	$\mu\text{A}$
Output Low Voltage	$V_{OL}^*$	$I_{OL}=+10\text{mA}$	-	0.15	0.4	V
Output High Voltage	$V_{OH}^*$	$I_{OH}=-30\text{mA}$	2.7	4.1	-	V
Output Low Current	$I_{OL}^*$	$V_{OL}=0.8V$	25.0	45.0	-	mA
Output High Current	$I_{OH}^*$	$V_{OH}=2.4V$	-	-53.0	-35.0	mA
Supply Current	$I_{DD}^*$	Unloaded	-	22.0	30.0	mA
Pull-up Resistor Value	$R_{pu}^*$		-	400.0	800.0	k ohm
AC Characteristics						
Rise Time	$T_r^*$	15pF load 0.8 to 2.0V		1.0	1.5	ns
Fall Time	$T_f^*$	15pF load 2.0 to 0.8V		1.0	1.5	ns
Lock Time	$T_L^*$	15pF load, 20% to 80%			10.0	ms
Duty Cycle	$D_i^*$	15pF load @ 50% of $V_{DD}$ ; Except UART	45.0	50.0	55.0	%
Duty Cycle	$D_i^*$	15pF load @ 50% of $V_{DD}$ ; UART only	40.0	45.0	50.0	%
Jitter, One Sigma	$T_{jis}^*$	Audio		50.0	80.0	ps
Jitter, Absolute	$T_{jab}^*$	Audio	-300		+300	ps
Jitter, One Sigma	$T_{jis}^*$	REFCLK, UART		1.0	3.0	ps
Jitter Absolute	$T_{jab}^*$	REFCLK, UART	-5.0		+5.0	ns
Power-up Time	$T_{pu}^*$	0 to 33.8MHz	-	2.5	4.8	ms
Crystal Input Capacitance	$C_{inx}^*$	X1 (Pin 1), X2 (Pin 8)	-	18	-	pF

\*Parameter is guaranteed by design and characterization. Not 100% tested in production.

# ICS9118-03

## ICS9118-04 Obsolete



### Electrical Characteristics at 3.3V

Operation  $V_{DD} = +3.0$  to  $+3.7$  V,  $T_A = 0$  to  $70^\circ\text{C}$  unless otherwise stated

DC Characteristics						
PARAMETER	SYMBOL	TEST CONDITIONS	MIN	TYP	MAX	UNITS
Input Low Voltage	$V_{IL}$		-	-	0.8	V
Input High Voltage	$V_{IH}$		2.0	-	-	V
Input Low Current	$I_{IL}$	$V_{IN}=0\text{V}$	-	8.3	-18.0	$\mu\text{A}$
Input High Current	$I_{IH}$	$V_{IN}=V_{DD}$	-	-	5.0	$\mu\text{A}$
Output Low Voltage	$V_{OL}^*$	$I_{OL}=+10\text{mA}$	-	0.15	0.4	V
Output High Voltage	$V_{OH}^*$	$I_{OH}=-10\text{mA}$	2.7	3.0	-	V
Output Low Current	$I_{OL}^*$	$V_{OL}=0.8\text{V}$	25.0	45.0	-	mA
Output High Current	$I_{OH}^*$	$V_{OH}=2.4\text{V}$	-	-53.0	-10.0	mA
Supply Current	$I_{DD}^*$	Unloaded	-	14.0	25.0	mA
Pull-up Resistor Value	$R_{pu}^*$		-	400.0	800.0	k ohm
AC Characteristics						
Rise Time	$T_r^*$	15pF load 0.8 to 2.0V		1.0	1.5	ns
Fall Time	$T_f^*$	15pF load 2.0 to 0.8V		1.0	1.5	ns
Lock Time	$T_L^*$	15pF load, 20% to 80%			10.0	ms
Duty Cycle	$D_t^*$	15pF load @ 50% of $V_{DD}$ ; Except UART	45.0	50.0	55.0	%
Duty Cycle	$D_t^*$	15pF load @ 50% of $V_{DD}$ ; UART only	40.0	45.0	50.0	%
Jitter, One Sigma	$T_{jis}^*$	Audio		50.0	80.0	ps
Jitter, Absolute	$T_{jab}^*$	Audio	-300		+300	ps
Jitter, One Sigma	$T_{jis}^*$	REFCLK, UART		1.0	3.0	ps
Jitter Absolute	$T_{jab}^*$	REFCLK, UART	-5.0		+5.0	%
Power-up Time	$T_{pu}^*$	0 to 33.8MHz	-	2.5	4.5	%
Crystal Input Capacitance	$C_{inx}^*$	X1 (Pin 1), X2 (Pin 8)	-	18	-	pF

\*Parameter is guaranteed by design and characterization. Not 100% tested in production.

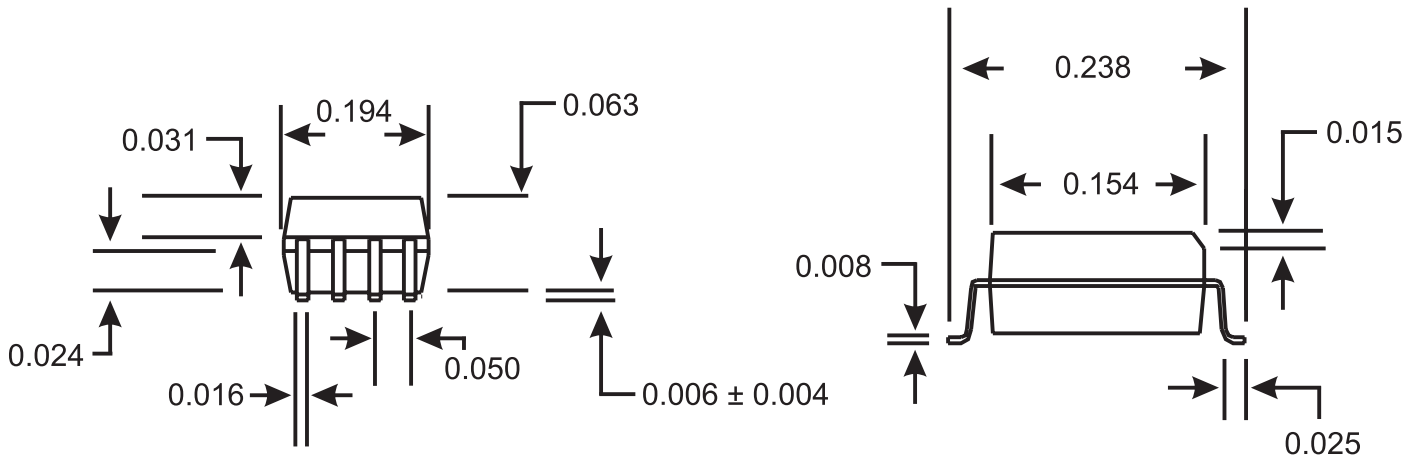

**8 Pin SOIC Package**

## Ordering Information

**ICS9118M-03**

Example:

**ICS XXXX M-PPP**

