



Frequency Generator & Integrated Buffers for PENTIUM/Pro™

General Description

The ICS9248-127 is the single chip clock solution for Desktop designs using the VIA MVP4 and Aladdin 7 style chipset. It provides all necessary clock signals for such a system.

Spread spectrum may be enabled through I²C programming. Spread spectrum typically reduces system EMI by 8dB to 10dB. This simplifies EMI qualification without resorting to board design iterations or costly shielding. The ICS9248-127 employs a proprietary closed loop design, which tightly controls the percentage of spreading over process and temperature variations.

Features

- Up to 124MHz frequency support.
- Spread Spectrum for EMI control 0 to -0.5% down spread and ±0.25% center spread
- Serial I²C interface for Power Management, Frequency Select, Spread Spectrum.
- Provides the following system clocks
 - 4-CPU's @ 3.3V, up to 124MHz.
 - 13-SDRAMs @3.3V, up to 124MHz (including SDRAM_F)
 - 6-PCI (including 1 free running, PCICLK_F) @3.3V, CPU/2 or CPU/3.
 - 1-24MHz @3.3V fixed.
 - 1-48MHz @3.3V fixed.
 - 2-REF @3.3V, 14.318MHz.
- Efficient Power management scheme through PCI and STOP CLOCKS.

Block Diagram

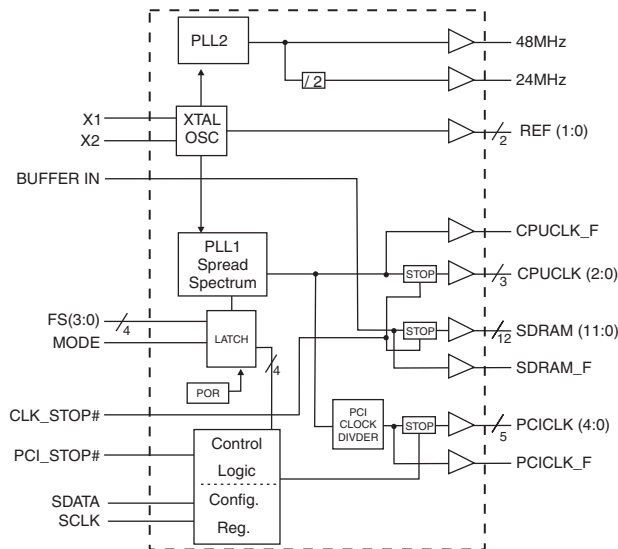

Pin Configuration

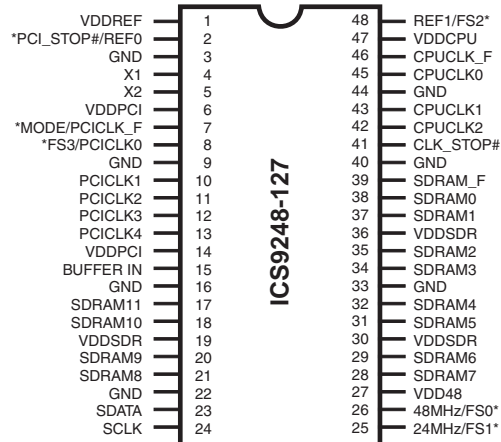

48-Pin SSOP

* Internal Pull-up Resistor of 240K to VDD

Power Groups

VDDCPU, GNDCPU = CPUCLKS, CPUCLK_F
 VDDSDR, GNDSDR = SDRAMCLKS, SDRAM_F
 VDDPCI, GNDDPCI = PCICLKs, PCICLK_F
 VDD48 = 48MHz, 24MHz
 VDDREF, GNDREF = REF, X1, X2

Pentium is a trademark of Intel Corporation
 I²C is a trademark of Philips Corporation

ICS9248-127



Pin Descriptions

PIN NUMBER	PIN NAME	TYPE	DESCRIPTION
1, 6, 14, 19, 27, 30, 36, 47	VDD	PWR	3.3V power supply
2	REF0	OUT	14.318 Mhz reference clock. This REF output is the STRONGER buffer for ISA BUS loads
	PCI_STOP# ¹	IN	Halts PCICLK clocks at logic 0 level, when input low (In mobile mode, MODE=0)
3,9,16,22, 33,40,44	GND	PWR	Ground
4	X1	IN	Crystal input, has internal load cap (36pF) and feedback resistor from X2
5	X2	OUT	Crystal output, nominally 14.318MHz.
7	PCICLK_F	OUT	Free running PCI clock not affected by PCI_STOP# for power management.
	MODE ^{1,2}	IN	pin 2 function select pin, 1=Desktop Mode, 0=Mobile Mode. Latched Input.
8	FS3 ¹	IN	Frequency select pin. Latched Input.
	PCICLK0	OUT	PCI clock outputs. Synchrous to CPU clocks with 1-4ns skew (CPU early)
13, 12, 11, 10	PCICLK (4:1)	OUT	PCI clock outputs. Synchrous to CPU clocks with 1-4ns skew (CPU early)
15	BUFFER IN	IN	Input to Fanout Buffers for SDRAM outputs.
17, 18, 20, 21, 28, 29, 31, 32, 34, 35, 37, 38	SDRAM (11:0)	OUT	SDRAM clock outputs, Fanout Buffer outputs from BUFFER IN pin (controlled by chipset).
23	SDATA	I/O	Data pin for I ² C circuitry 5V tolerant
24	SCLK	IN	Clock pin of I ² C circuitry 5V tolerant
25	24MHz	OUT	24MHz output clock
	FS1 ^{1,2}	IN	Frequency select pin. Latched Input.
26	48MHz	OUT	48MHz output clock
	FS0 ^{1,2}	IN	Frequency select pin. Latched Input
39	SDRAM_F	OUT	Free running SDRAM clock output. Not affected by CPU_STOP#
41	CLK_STOP#	IN	This asynchronous input halts CPUCLK & SDRAM at logic "0" level when driven low.
42, 43, 45	CPUCLK (2:0)	OUT	CPU clock outputs, powered by VDDCPU
46	CPUCLK_F	OUT	Free running CPU clock. Not affected by the CPU_STOP#
48	REF1	OUT	14.318 MHz reference clock.
	FS2 ^{1,2}	IN	Frequency select pin. Latched Input

Notes:

- 1: Internal Pull-up Resistor of 240K to 3.3V on indicated inputs
- 2: Bidirectional input/output pins, input logic levels are latched at internal power-on-reset. Use 10Kohm resistor to program logic Hi to VDD or GND for logic low.



Mode Pin - Power Management Input Control

MODE (Latched Input)	Pin 2
0	PCI_STOP# (Input)
1	REF0 (Output)

Functionality

V_{DD1,2,3} = 3.3V±5%, TA=0 to 70°C
Crystal (X1, X2) = 14.31818MHz

FS3	FS2	FS1	FS0	CPU (MHz)	PCI (MHz)
0	0	0	0	124.00	41.33
0	0	0	1	120.00	40.00
0	0	1	0	114.99	38.33
0	0	1	1	109.99	36.66
0	1	0	0	105.00	35.00
0	1	0	1	83.31	41.65
0	1	1	0	80.00	40.00
0	1	1	1	75.00	37.50
1	0	0	0	100.00	33.33
1	0	0	1	95.19	31.73
1	0	1	0	83.31	27.77
1	0	1	1	97.00	32.33
1	1	0	0	90.00	30.00
1	1	0	1	70.00	35.00
1	1	1	0	66.82	33.41
1	1	1	1	60.00	30.00



Serial Configuration Command Bitmap

Byte0: Functionality and Frequency Select Register (default = 0)

Bit	Description			PWD
Bit 7	0 - $\pm 0.25\%$ Center Spread Spectrum Modulation 1 - 0 to -0.5% Down Spread Spectrum Modulation			1
Bit [2, 6:4]	Bit [2, 6:4]	CPUCLK (MHz)	PCICLK (MHz)	Note1 0,010
	0000	124.00	41.33	
	0001	120.00	40.00	
	0010	114.99	38.33	
	0011	109.99	36.66	
	0100	105.00	35.00	
	0101	83.31	41.65	
	0110	80.00	40.00	
	0111	75.00	37.50	
	1000	100.00	33.33	
	1001	95.19	31.73	
	1010	83.31	27.77	
	1011	97.00	32.33	
	1100	90.00	30.00	
	1101	70.00	35.00	
	1110	66.82	33.41	
1111	60.00	30.00		
Bit 3	0 - Frequency is selected by hardware select, latched inputs 1 - Frequency is selected by Bit [2, 6:4]			0
Bit 1	0 - Normal 1 - Spread Spectrum Enabled			Note 2 1
Bit 0	0 - Running 1 - Tristate all outputs			0

Note 1. Default at Power-up will be for latched logic inputs to define frequency.

I²C readback of the power up default indicate the revision ID code in bit 2, 6:4 as shown.

Note 2. To ensure normal operation, Bit 7 needs to be "0" when in non - spread spectrum mode (Bit 1 = 0).

Note: PWD = Power-Up Default.



Byte 1: CPU, Active/Inactive Register (1 = enable, 0 = disable)

Bit	Pin #	PWD	Description
Bit 7	-	X	Latched FS2#
Bit 6	46	1	CPUCLK_F (Act/Inact)
Bit 5	-	1	(Reserved)
Bit 4	-	1	(Reserved)
Bit 3	39	1	SDRAM_F (Act/Inact)
Bit 2	42	1	CPUCLK2 (Act/Inact)
Bit 1	43	1	CPUCLK1 (Act/Inact)
Bit 0	45	1	CPUCLK0 (Act/Inact)

Byte 2: PCI Active/Inactive Register (1 = enable, 0 = disable)

Bit	Pin #	PWD	Description
Bit 7	-	X	Latched FS0#
Bit 6	7	1	PCICLK_F (Act/Inact)
Bit 5	-	1	(Reserved)
Bit 4	13	1	PCICLK4 (Act/Inact)
Bit 3	12	1	PCICLK3 (Act/Inact)
Bit 2	11	1	PCICLK2 (Act/Inact)
Bit 1	10	1	PCICLK1 (Act/Inact)
Bit 0	8	1	PCICLK0 (Act/Inact)

Byte 3: SDRAM Active/Inactive Register (1 = enable, 0 = disable)

Bit	Pin #	PWD	Description
Bit 7	17	1	SDRAM11 (Active/Inactive)
Bit 6	18	1	SDRAM10 (Active/Inactive)
Bit 5	20	1	SDRAM9 (Active/Inactive)
Bit 4	21	1	SDRAM8 (Active/Inactive)
Bit 3	28	1	SDRAM7 (Active/Inactive)
Bit 2	29	1	SDRAM6 (Active/Inactive)
Bit 1	31	1	SDRAM5 (Active/Inactive)
Bit 0	32	1	SDRAM4 (Active/Inactive)

Notes:

1. Inactive means outputs are held LOW and are disabled from switching.
2. Latched Frequency Selects (FS#) will be inverted logic load of the input frequency select pin conditions.

ICS9248-127



Byte 4: Reserved Active/Inactive Register (1 = enable, 0 = disable)

Bit	Pin #	PWD	Description
Bit 7	-	1	(Reserved)
Bit 6	-	1	(Reserved)
Bit 5	-	1	(Reserved)
Bit 4	-	1	(Reserved)
Bit 3	-	X	Latched FS1#
Bit 2	-	1	(Reserved)
Bit 1	-	X	Latched FS3#
Bit 0	-	1	(Reserved)

Byte 5: Peripheral Active/Inactive Register (1 = enable, 0 = disable)

Bit	Pin #	PWD	Description
Bit 7	34	1	SDRAM3 (Act/Inact)
Bit 6	35	1	SDRAM2 (Act/Inact)
Bit 5	37	1	SDRAM1 (Act/Inact)
Bit 4	38	1	SDRAM0 (Act/Inact)
Bit 3	26	1	48MHz (Act/Inact)
Bit 2	25	1	24MHz (Act/Inact)
Bit 1	48	1	REF1 (Act/Inact)
Bit 0	2	1	REF0 (Act/Inact)

Notes:

1. Inactive means outputs are held LOW and are disabled from switching.
2. Latched Frequency Selects (FS#) will be inverted logic load of the input frequency select pin conditions.



Absolute Maximum Ratings

- Supply Voltage 5.5 V
- Logic Inputs GND–0.5 V to V_{DD}+0.5 V
- Ambient Operating Temperature 0°C to +70°C
- Case Temperature 115°C
- Storage Temperature –65°C to +150°C

Stresses above those listed under *Absolute Maximum Ratings* may cause permanent damage to the device. These ratings are stress specifications only and functional operation of the device at these or any other conditions above those listed in the operational sections of the specifications is not implied. Exposure to absolute maximum rating conditions for extended periods may affect product reliability.

Electrical Characteristics - Input/Supply/Common Output Parameters

T_A = 0 - 70C; Supply Voltage V_{DD} = 3.3 V +/-5% (unless otherwise stated)

PARAMETER	SYMBOL	CONDITIONS	MIN	TYP	MAX	UNITS
Input High Voltage	V _{IH}		2		V _{DD} +0.3	V
Input Low Voltage	V _{IL}		V _{SS} -0.3		0.8	V
Supply Current	I _{DD3.3}	C _L = 0 pF; Select @ 66M		77	180	mA
Input frequency	F _i	V _{DD} = 3.3 V;		14.318		MHz
Input Capacitance ¹	C _{IN}	Logic Inputs			5	pF
	C _{INX}	X1 & X2 pins	27	36	45	pF
Transition Time ¹	T _{trans}	To 1st crossing of target Freq.		1.5	3	ms
Settling Time ¹	T _s	From 1st crossing to 1% target Freq.				ms
Clk Stabilization ¹	T _{STAB}	From V _{DD} = 3.3 V to 1% target Freq.			3	ms
Skew ¹	T _{CPU-BUS}	V _T = 1.5 V;	1.0	2.2	4.0	ns

¹Guarenteed by design, not 100% tested in production.

ICS9248-127



Electrical Characteristics - CPU

T_A = 0 - 70C; V_{DD}=3.3V +/-5%; C_L = 20 pF (unless otherwise specified)

PARAMETER	SYMBOL	CONDITIONS	MIN	TYP	MAX	UNITS
Output Impedance	R _{DSP2B} ¹	V _O =V _{DD} *(0.5)	10		20	Ω
Output Impedance	R _{DSN2B} ¹	V _O =V _{DD} *(0.5)	10		20	Ω
Output High Voltage	V _{OH2B}	I _{OH} = -12 mA	2.0	2.3		V
Output Low Voltage	V _{OL2B}	I _{OL} = 12 mA		0.2	0.4	V
Output High Current	I _{OH2B}	V _{OH} = 1.7 V		-41	-19	mA
Output Low Current	I _{OL2B}	V _{OL} = 0.7 V	19.0	37.0		mA
Rise Time ¹	t _{r2B}	V _{OL} = 0.4 V, V _{OH} = 2.4 V	0.4	1.28	2.0	ns
Fall Time ¹	t _{f2B}	V _{OH} = 2.4 V, V _{OL} = 0.4 V	0.4	1.49	2.0	ns
Duty Cycle ¹	d _{t2B}	V _T = 1.5 V	48.0	54.8	58.0	%
Skew window ¹	t _{sk2B}	V _T = 1.5 V		222	250	ps
Jitter, Cycle-to-cycle ¹	t _{jycyc-cyc2B}	V _T = 1.5 V		152	250	ps

¹Guaranteed by design, not 100% tested in production.

Electrical Characteristics - 24MHz, 48MHz, REF

T_A = 0 - 70C; V_{DD}=3.3V +/-5%; C_L = 20 pF (unless otherwise specified)

PARAMETER	SYMBOL	CONDITIONS	MIN	TYP	MAX	UNITS
Output Impedance	R _{DSP5} ¹	V _O =V _{DD} *(0.5)	20		60	Ω
Output Impedance	R _{DSN5} ¹	V _O =V _{DD} *(0.5)	20		60	Ω
Output High Voltage	V _{OH5}	I _{OH} = -14 mA	2.4	2.9		V
Output Low Voltage	V _{OL5}	I _{OL} = 6.0 mA		0.25	0.4	V
Output High Current	I _{OH5}	V _{OH} = 2.0 V		-42	-20	mA
Output Low Current	I _{OL5}	V _{OL} = 0.8 V	10	18		mA
Rise Time ¹	t _{r5}	V _{OL} = 0.4 V, V _{OH} = 2.4 V		1.74	4.0	ns
Fall Time ¹	t _{f5}	V _{OH} = 2.4 V, V _{OL} = 0.4 V		2.05	4.0	ns
Duty Cycle ¹	d _{t5}	V _T = 1.5 V,	45	53.2	55	%
Jitter ¹	t _{jabs5}	V _T = 1.5 V		307	800	ps

¹Guaranteed by design, not 100% tested in production.



Electrical Characteristics - PCI

T_A = 0 - 70°C; V_{DD}=3.3V +/-5%; C_L = 30 pF (unless otherwise specified)

PARAMETER	SYMBOL	CONDITIONS	MIN	TYP	MAX	UNITS
Output Impedance	R _{DSP1} ¹	V _O =V _{DD} *(0.5)	12	23	55	Ω
Output Impedance	R _{DSN1} ¹	V _O =V _{DD} *(0.5)	12	20	55	Ω
Output High Voltage	V _{OH1}	I _{OH} = -18 mA	2.4	2.9		V
Output Low Voltage	V _{OL1}	I _{OL} = 9.4 mA		0.2	0.4	V
Output High Current	I _{OH1}	V _{OH} = 2.0 V		-58	-22	mA
Output Low Current	I _{OL1}	V _{OL} = 0.8 V	25	52		mA
Rise Time ¹	t _{r1}	V _{OL} = 0.4 V, V _{OH} = 2.4 V		1.38	2.0	ns
Fall Time ¹	t _{f1}	V _{OH} = 2.4 V, V _{OL} = 0.4 V		1.65	2.0	ns
Duty Cycle ¹	d _{t1}	V _T = 1.5 V	45	51.1	55	%
Skew window ¹	t _{sk1}	V _T = 1.5 V		236	500	ps
Jitter	t _{jabs1} ¹	V _T = 1.5 V		214	500	ps

¹Guaranteed by design, not 100% tested in production.

Electrical Characteristics - SDRAM

T_A = 0 - 70°C; V_{DD}=3.3V +/-5%; C_L = 30 pF (unless otherwise specified)

PARAMETER	SYMBOL	CONDITIONS	MIN	TYP	MAX	UNITS
Output Impedance	R _{DSP2A} ¹	V _O =V _{DD} *(0.5)	10		20	Ω
Output Impedance	R _{DSN2A} ¹	V _O =V _{DD} *(0.5)	10		20	Ω
Output High Voltage	V _{OH2A}	I _{OH} = -28 mA	2.4	2.8		V
Output Low Voltage	V _{OL2A}	I _{OL} = 19 mA		0.3	0.4	V
Output High Current	I _{OH2A}	V _{OH} = 2.0 V		-72	-42	mA
Output Low Current	I _{OL2A}	V _{OL} = 0.8 V	33	50		mA
Rise Time ¹	t _{r2A}	V _{OL} = 0.4 V, V _{OH} = 2.4 V	0.5	0.97	1.6	ns
Fall Time ¹	t _{f2A}	V _{OH} = 2.4 V, V _{OL} = 0.4 V	0.5	1.07	1.6	ns
Duty Cycle ¹	d _{t2A}	V _T = 1.5 V	45	49.1	55	%
Skew Window ¹	t _{sk2A}	V _T = 1.5 V		145	250	ps
Skew (Buffer-In to SDRAM) ¹	t _{sk2A}	V _T = 1.5 V		3.5	5	ps

¹Guaranteed by design, not 100% tested in production.



General I²C serial interface information

The information in this section assumes familiarity with I²C programming.
For more information, contact ICS for an I²C programming application note.

How to Write:

- Controller (host) sends a start bit.
- Controller (host) sends the write address D2_(H)
- ICS clock will **acknowledge**
- Controller (host) sends a dummy command code
- ICS clock will **acknowledge**
- Controller (host) sends a dummy byte count
- ICS clock will **acknowledge**
- Controller (host) starts sending first byte (Byte 0) through byte 5
- ICS clock will **acknowledge** each byte *one at a time*.
- Controller (host) sends a Stop bit

How to Write:	
Controller (Host)	ICS (Slave/Receiver)
Start Bit	
Address D2 _(H)	
	ACK
Dummy Command Code	
	ACK
Dummy Byte Count	
	ACK
Byte 0	
	ACK
Byte 1	
	ACK
Byte 2	
	ACK
Byte 3	
	ACK
Byte 4	
	ACK
Byte 5	
	ACK
Stop Bit	

How to Read:

- Controller (host) will send start bit.
- Controller (host) sends the read address D3_(H)
- ICS clock will **acknowledge**
- ICS clock will send the **byte count**
- Controller (host) acknowledges
- ICS clock sends first byte (**Byte 0**) through **byte 5**
- Controller (host) will need to acknowledge each byte
- Controller (host) will send a stop bit

How to Read:	
Controller (Host)	ICS (Slave/Receiver)
Start Bit	
Address D3 _(H)	
	ACK
	Byte Count
ACK	
	Byte 0
ACK	
	Byte 1
ACK	
	Byte 2
ACK	
	Byte 3
ACK	
	Byte 4
ACK	
	Byte 5
ACK	
Stop Bit	

Notes:

1. The ICS clock generator is a slave/receiver, I²C component. It can read back the data stored in the latches for verification. **Read-Back will support Intel PIIX4 "Block-Read" protocol.**
2. The data transfer rate supported by this clock generator is 100K bits/sec or less (standard mode)
3. The input is operating at 3.3V logic levels.
4. The data byte format is 8 bit bytes.
5. To simplify the clock generator I²C interface, the protocol is set to use only "**Block-Writes**" from the controller. The bytes must be accessed in sequential order from lowest to highest byte with the ability to stop after any complete byte has been transferred. The Command code and Byte count shown above must be sent, but the data is ignored for those two bytes. The data is loaded until a Stop sequence is issued.
6. At power-on, all registers are set to a default condition, as shown.



Shared Pin Operation - Input/Output Pins

The I/O pins designated by (input/output) on the ICS9248-127 serve as dual signal functions to the device. During initial power-up, they act as input pins. The logic level (voltage) that is present on these pins at this time is read and stored into a 5-bit internal data latch. At the end of Power-On reset, (see AC characteristics for timing values), the device changes the mode of operations for these pins to an output function. In this mode the pins produce the specified buffered clocks to external loads.

To program (load) the internal configuration register for these pins, a resistor is connected to either the VDD (logic 1) power supply or the GND (logic 0) voltage potential. A 10 Kilohm (10K) resistor is used to provide both the solid CMOS programming voltage needed during the power-up programming period and to provide an insignificant load on the output clock during the subsequent operating period.

Figure 1 shows a means of implementing this function when a switch or 2 pin header is used. With no jumper is installed the pin will be pulled high. With the jumper in place the pin will be pulled low. If programmability is not necessary, than only a single resistor is necessary. The programming resistors should be located close to the series termination resistor to minimize the current loop area. It is more important to locate the series termination resistor close to the driver than the programming resistor.

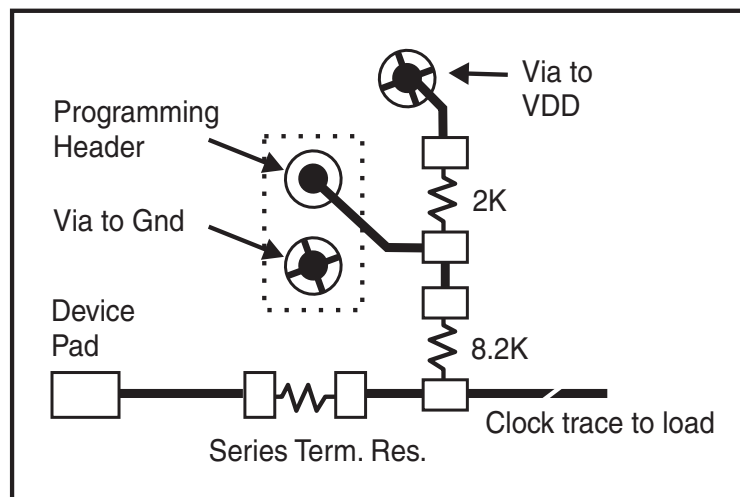
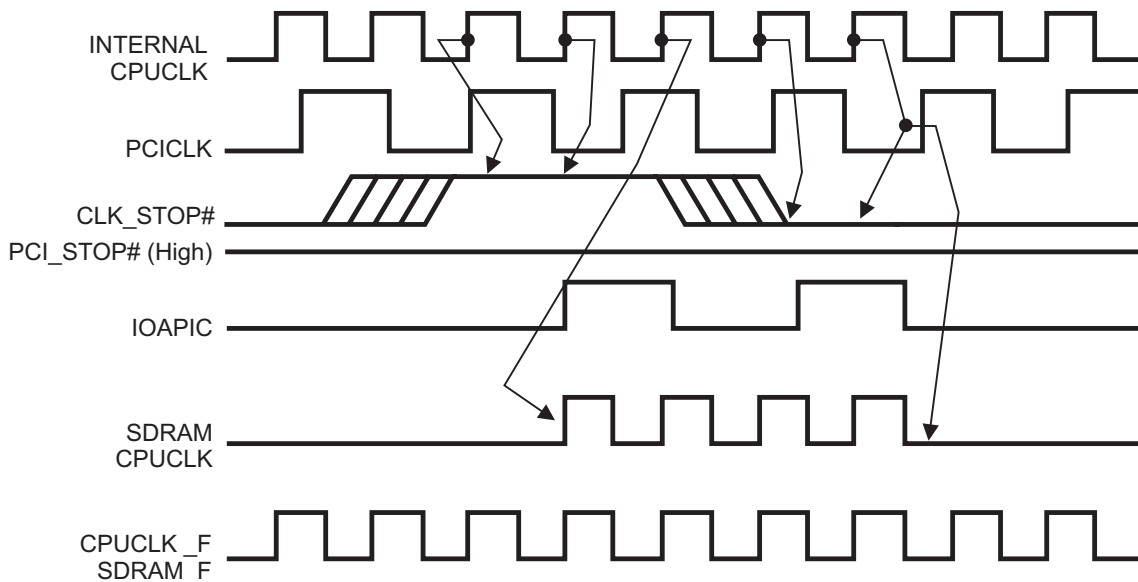

Fig. 1



CLK_STOP# Timing Diagram

CLK_STOP# is an asynchronous input to the clock synthesizer. It is used to turn off the CPU clocks for low power operation. CLK_STOP# is synchronized by the ICS9248-127. The minimum that the CPU clock is enabled (CPU_STOP# high pulse) is 100 CPU clocks. All other clocks will continue to run while the CPU clocks are disabled. The CPU clocks will always be stopped in a low state and start in such a manner that guarantees the high pulse width is a full pulse. CPU clock on latency is less than 4 CPU clocks and CPU clock off latency is less than 4 CPU clocks.



Notes:

1. All timing is referenced to the internal CPU clock.
2. CLK_STOP# is an asynchronous input and metastable conditions may exist. This signal is synchronized to the CPU clocks inside the ICS9248-127.
3. IOAPIC output is Stopped Glitch Free by CPUSTOP# going low.
4. SDRAM-F output is controlled by Buffer in signal, not affected by the ICS9248-127 CLK_STOP# signal. SDRAM (0:11) are controlled as shown.
5. All other clocks continue to run undisturbed.



PCI_STOP# Timing Diagram

PCI_STOP# is an asynchronous input to the ICS9248-127. It is used to turn off the PCICLK [4:0] clocks for low power operation. PCI_STOP# is synchronized by the ICS9248-127 internally. The minimum that the PCICLK [4:0] clocks are enabled (PCI_STOP# high pulse) is at least 10 PCICLK [4:0] clocks. PCICLK [4:0] clocks are stopped in a low state and started with a full high pulse width guaranteed. PCICLK [4:0] clock on latency cycles are only one rising PCICLK clock off latency is one PCICLK clock.

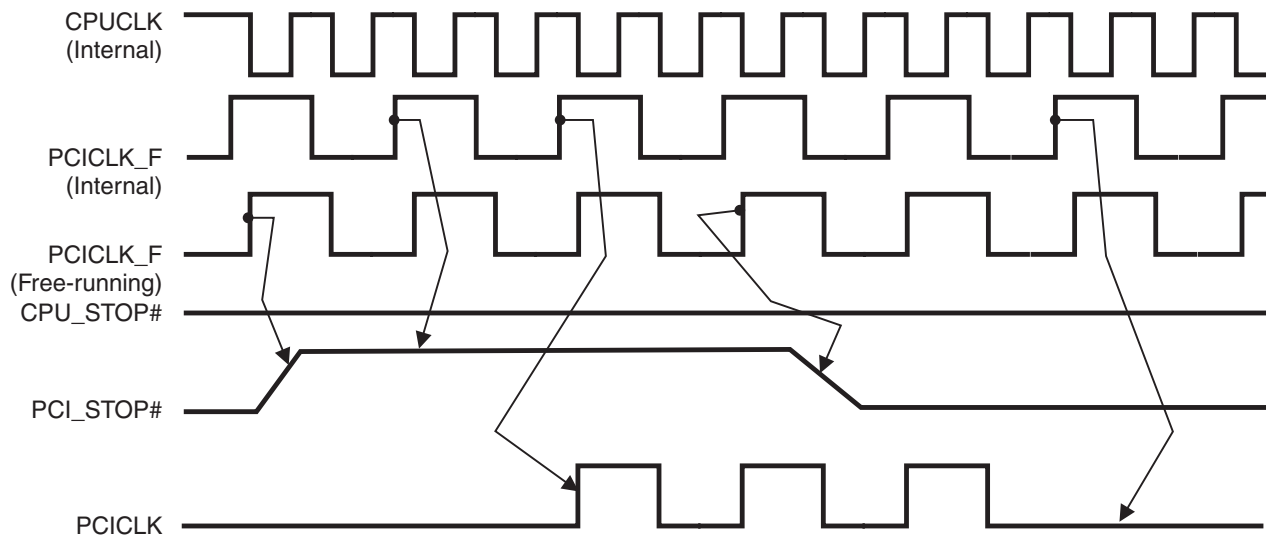

Notes:

1. All timing is referenced to the Internal CPUCLK (defined as inside the ICS9248 device.)
2. PCI_STOP# is an asynchronous input, and metastable conditions may exist. This signal is required to be synchronized inside the ICS9248.
3. All other clocks continue to run undisturbed.
4. CPU_STOP# is shown in a high (true) state.

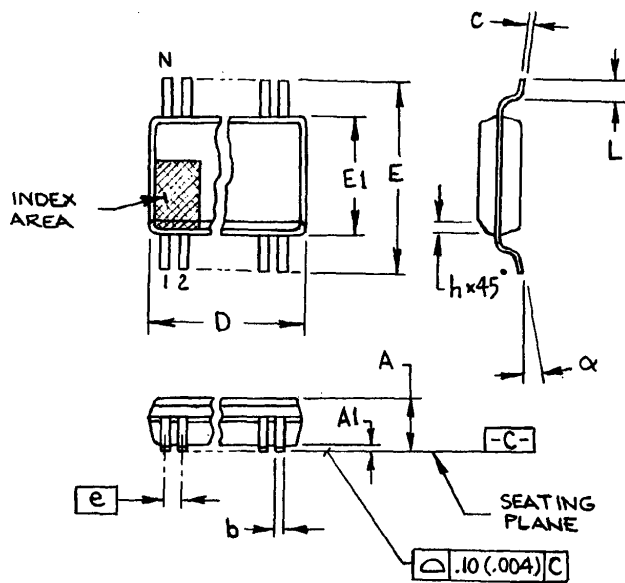

300 mil SSOP

SYMBOL	In Millimeters COMMON DIMENSIONS		In Inches COMMON DIMENSIONS	
	MIN	MAX	MIN	MAX
A	2.413	2.794	.095	.110
A1	0.203	0.406	.008	.016
b	0.203	0.343	.008	.0135
c	0.127	0.254	.005	.010
D	SEE VARIATIONS		SEE VARIATIONS	
E	10.033	10.668	.395	.420
E1	7.391	7.595	.291	.299
e	0.635 BASIC		0.025 BASIC	
h	0.381	0.635	.015	.025
L	0.508	1.016	.020	.040
N	SEE VARIATIONS		SEE VARIATIONS	
α	0°	8°	0°	8°

VARIATIONS

N	D mm.		D (inch)	
	MIN	MAX	MIN	MAX
28	9.398	9.652	.370	.380
34	11.303	11.557	.445	.455
48	15.748	16.002	.620	.630
56	18.288	18.542	.720	.730
64	20.828	21.082	.820	.830

Ordering Information

ICS9248yF-127-T

Example:

ICS XXXX y F - PPP - T

