

# Frequency Timing Generator for Pentium II Systems

**Recommended Application:**

ALI1621/1632M style chipsets

**Output Features:**

- 2 - CPUs @2.5V, up to 140MHz.
- 7 - PCI @3.3V, (including one free running)
- 1 - 48MHz, @3.3V fixed.
- 2 - REF @3.3V, 14.318MHz.

**Features:**

- Up to 140 MHz frequency support
- Support power management: CPU, PCI stop and Power down.
- Spread spectrum for EMI control (0.5% down spread).
- Uses external 14.318MHz crystal
- FS pins for frequency select

**Key Specifications:**

- CPU – CPU: <175ps
- PCI – PCI: <250ps
- CPU(early)-PCI: 1.5ns - 4ns
- PCI\_E (early) - PCI: 2.1ns

**Pin Configuration**

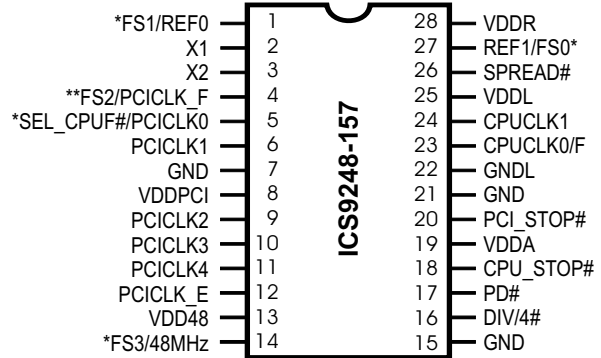

**28 Pin 209mil SSOP**

\*These inputs have a 120K pull up to VDD  
\*\*These inputs have a 120K pull down to GND

**Block Diagram**

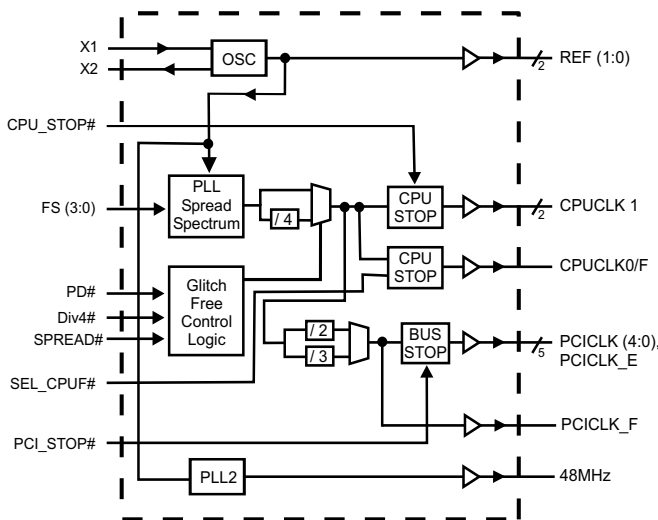

**Functionality**

FS3	FS2	FS1	FS0	CPU	PCI
0	0	0	0	33.33	16.66
0	0	0	1	63.33	31.66
0	0	1	0	69.99	35.00
0	0	1	1	66.66	33.33
0	1	0	0	97.00	32.33
0	1	0	1	96.22	32.07
0	1	1	0	91.50	30.50
0	1	1	1	83.33	27.77
1	0	0	0	50.00	16.66
1	0	0	1	95.25	31.75
1	0	1	0	105.00	35.00
1	0	1	1	100.00	33.33
1	1	0	0	66.66	16.66
1	1	0	1	126.35	31.66
1	1	1	0	139.65	35.00
1	1	1	1	133.33	33.33



## General Description

The **ICS9248-157** is the Main clock solution for Notebook designs using the Intel ALI1621/1632M style chipset. Along with an SDRAM buffer such as the ICS9179-03, it provides all necessary clock signals for such a system.

Spread spectrum may be enabled by driving pin 26, SPREAD# active (Low) at power-on. Spread spectrum typically reduces system EMI by 8dB to 10dB. This simplifies EMI qualification without resorting to board design iterations or costly shielding. The **ICS9248-157** employs a proprietary closed loop design, which tightly controls the percentage of spreading over process and temperature variations.

## Pin Descriptions

Pin number	Pin name	Type	Description
1	FS1	Input	Frequency select pin
	REF0	Output	3.3V, 14.318 MHz reference clock output.
2	X1	Input	14.318 MHz crystal input
3	X2	Output	14.318 MHz crystal output
4	FS2	Input	Frequency select pin
	PCICLK_F	Output	3.3 V free running PCI clock output, will not be stopped by the PCI_STOP#
5	SEL_CPUF#	Input	Active low input to select CPUCLK0/F (pin 23) either normal CPUCLK or Free running (not stoppable through CPU_STOP#) clock.
	PCICLK0	Output	3.3V PCI clock output
11, 10, 9, 6	PCICLK (4:1)	Output	3.3 V PCI clock outputs, generating timing requirements
7, 15, 21	GND	Power	Ground for clock outputs
8	VDDPCI	Power	3.3 V power for the PCI clock outputs
12	PCICLK_E	Output	Early PCICLK output, offset from other PCICLKs, stopped by PCI-STOP#
13	VDD48	Power	3.3 V power for 48 MHz clocks
14	FS3	Input	Frequency select pin
	48MHz	Output	Fixed 48MHz clock.
16	DIV4#	Input	Active low input, enables the CPUCLK and the PCICLK to run at 1/4 of the regular frequencies
17	PD#	Input	Asynchronous active low input pin used to power down the device into a low power state. The internal clocks are disabled and the VCO and the crystal are stopped. The latency of the power down will not be greater than 3ms.
18	CPU_STOP#	Input	Asynchronous active low input pin used to stop the CPUCLK in active low state, all other clocks will continue to run. The CPUCLK will have a "Turnon " latency of at least 3 CPU clocks.
19	VDDA	Power	3.3 V power for the core
20	PCI-STOP#	Input	Synchronous active low input used to stop the PCICLK in active low state. It will not effect PCICLK_F or any other outputs.
22	GNDL	Power	Ground for the CPU and Host clock outputs
23	CPUCLK0/F	Output	2.5V CPU clock output; can be selected to be free running by driving SEL_CPUF# low
24	CPUCLK1	Output	2.5 V CPU and Host clock outputs
25	VDDL	Power	2.5 V power for the CPU and Host clock outputs
26	SPREAD#	Input	power-on spread spectrum enable option. Active low = spread spectrum clocking enable. Active high = spread spectrum clocking disable.
27	FS0	Input	Frequency select pin
	REF1	Output	3.3V, 14.318 MHz reference clock output.
28	VDDR	Power	3.3 V power for the REFCLK and crystal clock outputs



## Power Management

### Clock Enable Configuration

CPU_STOP#	PCI_STOP#	PWR_DWN#	CPUCLK	PCICLK	PCICLK_F	REF	Crystal	VCOs
X	X	0	Low	Low	Low	Stopped	Off	Off
0	0	1	Low	Low	Running	Running	Running	Running
0	1	1	Low	Running	Running	Running	Running	Running
1	0	1	Running	Low	Running	Running	Running	Running
1	1	1	Running	Running	Running	Running	Running	Running

Full clock cycle timing is guaranteed at all times after the system has initially powered up except where noted. During power up and power down operations using the PD# pin will not cause clocks of a short or longer pulse than that of the running clock. The first clock pulse coming out of a stopped clock condition may be slightly distorted due to clock network charging circuitry. Board routing and signal loading may have a large impact on the initial clock distortion also.

### Power Management Requirements

SIGNAL	SIGNAL STATE	Latency No. of rising edges of free running PCICLK
CPU_STOP#	0 (Disabled) <sup>2</sup>	1
	1 (Enabled) <sup>1</sup>	1
PCI_STOP#	0 (Disabled) <sup>2</sup>	1
	1 (Enabled) <sup>1</sup>	1
PD#	1 (Normal Operation) <sup>3</sup>	3ms
	0 (Power Down) <sup>4</sup>	2max

#### Notes.

1. Clock on latency is defined from when the clock enable goes active to when the first valid clock comes out of the device.
2. Clock off latency is defined from when the clock enable goes inactive to when the last clock is driven low out of the device.
3. Power up latency is when PD# goes inactive (high) to when the first valid clocks are output by the device.
4. Power down has controlled clock counts applicable to CPUCLK, PCICLK only.  
The REF will be stopped independant of these.

#### Power Groups:

VDDA = PLL Core  
VDD48 = 48MHz Core  
VDDPCI = PCICLK  
VDDL = CPUCLK  
VDDR = Xtal & REF



## Absolute Maximum Ratings

Supply Voltage .....	5.5 V
Logic Inputs .....	GND -0.5 V to V <sub>DD</sub> +0.5 V
Ambient Operating Temperature .....	0°C to +70°C
Storage Temperature .....	-65°C to +150°C

Stresses above those listed under *Absolute Maximum Ratings* may cause permanent damage to the device. These ratings are stress specifications only and functional operation of the device at these or any other conditions above those listed in the operational sections of the specifications is not implied. Exposure to absolute maximum rating conditions for extended periods may affect product reliability.

## Electrical Characteristics - Input/Supply/Common Output Parameters

T<sub>A</sub> = 0 - 70°C; Supply Voltage V<sub>DD</sub> = 3.3 V +/-5% V<sub>DDL</sub> = 2.5 V +/-5% (unless otherwise stated)

PARAMETER	SYMBOL	CONDITIONS	MIN	TYP	MAX	UNITS
Input High Voltage	V <sub>IH</sub>		2		V <sub>DD</sub> +0.3	V
Input Low Voltage	V <sub>IL</sub>		V <sub>SS</sub> -0.3		0.8	V
Input High Current	I <sub>IH</sub>	V <sub>IN</sub> = V <sub>DD</sub>		0.1	5	μA
Input Low Current	I <sub>IL1</sub>	V <sub>IN</sub> = 0 V; Inputs with no pull-up resistors	-5	2.0		μA
Input Low Current	I <sub>IL2</sub>	V <sub>IN</sub> = 0 V; Inputs with pull-up resistors	-200	-100		μA
Operating Supply Current	I <sub>DD3.3OP66</sub>	C <sub>L</sub> = 0 pF; Select @ 66MHz		60	180	mA
	I <sub>DD3.3OP100</sub>	C <sub>L</sub> = 0 pF; Select @ 100MHz		66	180	mA
Power Down Supply Current	I <sub>DD3.3PD</sub>	C <sub>L</sub> = 0 pF; With input address to V <sub>DD</sub> or GND		70	600	μA
Input frequency	F <sub>i</sub>	V <sub>DD</sub> = 3.3 V;	11	14.318	16	MHz
Input Capacitance <sup>1</sup>	C <sub>IN</sub>	Logic Inputs			5	pF
	C <sub>INX</sub>	X1 & X2 pins	27	36	45	pF
Transition Time <sup>1</sup>	T <sub>trans</sub>	To 1st crossing of target Freq.			3	ms
Clk Stabilization <sup>1</sup>	T <sub>STAB</sub>	From V <sub>DD</sub> = 3.3 V to 1% target Freq.			3	ms
Skew <sup>1</sup>	T <sub>CPU-PCI1</sub>	V <sub>T</sub> = 1.5 V;	1.5	2.3	4	ns

<sup>1</sup>Guaranteed by design, not 100% tested in production.

## Electrical Characteristics - Input/Supply/Common Output Parameters

T<sub>A</sub> = 0 - 70°C; Supply Voltage V<sub>DD</sub> = 3.3 V +/-5%, V<sub>DDL</sub> = 2.5 V +/-5% (unless otherwise stated)

PARAMETER	SYMBOL	CONDITIONS	MIN	TYP	MAX	UNITS
Operating Supply Current	I <sub>DD2.5OP66</sub>	C <sub>L</sub> = 0 pF; Select @ 66.8 MHz		16	72	mA
	I <sub>DD2.5OP100</sub>	C <sub>L</sub> = 0 pF; Select @ 100 MHz		23	100	mA
Skew <sup>1</sup>	t <sub>CPU-PCI2</sub>	V <sub>T</sub> = 1.5 V; V <sub>TL</sub> = 1.25 V	1.5	3	4	ns

<sup>1</sup>Guaranteed by design, not 100% tested in production.



**Electrical Characteristics - CPUCLK**

T<sub>A</sub> = 0 - 70C; V<sub>DD</sub> = 3.3 V +/-5%, V<sub>DDL</sub> = 2.5 V +/-5%; C<sub>L</sub> = 10 - 20 pF (unless otherwise stated)

PARAMETER	SYMBOL	CONDITIONS	MIN	TYP	MAX	UNITS
Output High Voltage	V <sub>OH2B</sub>	I <sub>OH</sub> = -12.0 mA	2	2.3		V
Output Low Voltage	V <sub>OL2B</sub>	I <sub>OL</sub> = 12 mA		0.2	0.4	V
Output High Current	I <sub>OH2B</sub>	V <sub>OH</sub> = 1.7 V		-41	-19	mA
Output Low Current	I <sub>OL2B</sub>	V <sub>OL</sub> = 0.7 V	19	37		mA
Rise Time	t <sub>r2B</sub> <sup>1</sup>	V <sub>OL</sub> = 0.4 V, V <sub>OH</sub> = 2.0 V		0.99	1.6	ns
Fall Time	t <sub>f2B</sub> <sup>1</sup>	V <sub>OH</sub> = 2.0 V, V <sub>OL</sub> = 0.4 V		1.05	1.6	ns
Duty Cycle	d <sub>l2B</sub> <sup>1</sup>	V <sub>T</sub> = 1.25 V	45	50.3	55	%
Skew	t <sub>sk2B</sub> <sup>1</sup>	V <sub>T</sub> = 1.25 V		34	175	ps
Jitter, Cycle-to-cycle	t <sub>j<sub>cyc-cyc2B</sub></sub> <sup>1</sup>	V <sub>T</sub> = 1.25 V		203	250	ps
Jitter, One Sigma	t <sub>j<sub>1s2B</sub></sub> <sup>1</sup>	V <sub>T</sub> = 1.25 V			150	ps
Jitter, Absolute	t <sub>j<sub>abs2B</sub></sub> <sup>1</sup>	V <sub>T</sub> = 1.25 V	-250		+250	ps

<sup>1</sup>Guaranteed by design, not 100% tested in production.

**Electrical Characteristics - PCICLK**

T<sub>A</sub> = 0 - 70C; V<sub>DD</sub> = 3.3 V +/-5% VDDL = 2.5 V +/-5%; C<sub>L</sub> = 30 pF

PARAMETER	SYMBOL	CONDITIONS	MIN	TYP	MAX	UNITS
Output High Voltage	V <sub>OH1</sub>	I <sub>OH</sub> = -11 mA	2.4	3.1		V
Output Low Voltage	V <sub>OL1</sub>	I <sub>OL</sub> = 9.4 mA		0.1	0.4	V
Output High Current	I <sub>OH1</sub>	V <sub>OH</sub> = 2.0 V		-62	-22	mA
Output Low Current	I <sub>OL1</sub>	V <sub>OL</sub> = 0.8 V	16	57		mA
Rise Time <sup>1</sup>	t <sub>r1</sub>	V <sub>OL</sub> = 0.4 V, V <sub>OH</sub> = 2.4 V		1.5	2	ns
Fall Time <sup>1</sup>	t <sub>f1</sub>	V <sub>OH</sub> = 2.4 V, V <sub>OL</sub> = 0.4 V		1.1	2	ns
Duty Cycle <sup>1</sup>	d <sub>l1</sub>	V <sub>T</sub> = 1.5 V	45	50	55	%
Skew <sup>1</sup>	t <sub>sk1</sub>	V <sub>T</sub> = 1.5 V		290	500	ps
Jitter, Cycle-to-cycle	t <sub>j<sub>cyc-cyc1</sub></sub>	V <sub>T</sub> = 1.25 V		200	500	ps
Jitter, One Sigma <sup>1</sup>	t <sub>j<sub>1s1</sub></sub>	V <sub>T</sub> = 1.5 V			150	ps
Jitter, Absolute <sup>1</sup>	t <sub>j<sub>abs1</sub></sub>	V <sub>T</sub> = 1.5 V	-250		250	ps

<sup>1</sup>Guaranteed by design, not 100% tested in production.



## Electrical Characteristics - REF/48MHz

$T_A = 0 - 70^\circ\text{C}$ ;  $V_{DDL} = 2.5\text{V} \pm 5\%$ ;  $V_{DD} = 3.3\text{V} \pm 5\%$ ;  $C_L = 10 - 20\text{ pF}$  (unless otherwise stated)

PARAMETER	SYMBOL	CONDITIONS	MIN	TYP	MAX	UNITS
Output High Voltage	$V_{OH5}$	$I_{OH} = -12\text{ mA}$	2.6	3.1		V
Output Low Voltage	$V_{OL5}$	$I_{OL} = 9\text{ mA}$		0.17	0.4	V
Output High Current	$I_{OH5}$	$V_{OH} = 2.0\text{ V}$		-44	-22	mA
Output Low Current	$I_{OL5}$	$V_{OL} = 0.8\text{ V}$	16	42		mA
Rise Time <sup>1</sup>	$t_{r5}$	$V_{OL} = 0.4\text{ V}, V_{OH} = 2.4\text{ V}$		1.03	4	ns
Fall Time <sup>1</sup>	$t_{f5}$	$V_{OH} = 2.4\text{ V}, V_{OL} = 0.4\text{ V}$		0.9	4	ns
Duty Cycle <sup>1</sup>	$d_{15}$	$V_T = 1.5\text{ V}$	45	52.9	55	%
Jitter, One Sigma <sup>1</sup>	$t_{j1s5}$	$V_T = 1.5\text{ V}$			3	%
Jitter, Absolute <sup>1</sup>	$t_{jabs5}$	$V_T = 1.5\text{ V}$			5	%

<sup>1</sup>Guaranteed by design, not 100% tested in production.



## Shared Pin Operation - Input/Output Pins

The I/O pins designated by (input/output) on the ICS9248-157 serve as dual signal functions to the device. During initial power-up, they act as input pins. The logic level (voltage) that is present on these pins at this time is read and stored into a 5-bit internal data latch. At the end of Power-On reset, (see AC characteristics for timing values), the device changes the mode of operations for these pins to an output function. In this mode the pins produce the specified buffered clocks to external loads.

To program (load) the internal configuration register for these pins, a resistor is connected to either the VDD (logic 1) power supply or the GND (logic 0) voltage potential. A 10 Kilohm (10K) resistor is used to provide both the solid CMOS programming voltage needed during the power-up programming period and to provide an insignificant load on the output clock during the subsequent operating period.

Figure 1 shows a means of implementing this function when a switch or 2 pin header is used. With no jumper is installed the pin will be pulled high. With the jumper in place the pin will be pulled low. If programmability is not necessary, than only a single resistor is necessary. The programming resistors should be located close to the series termination resistor to minimize the current loop area. It is more important to locate the series termination resistor close to the driver than the programming resistor.

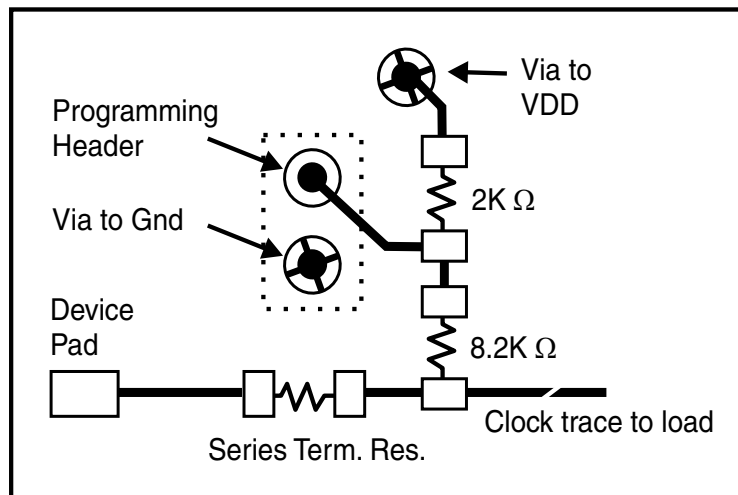
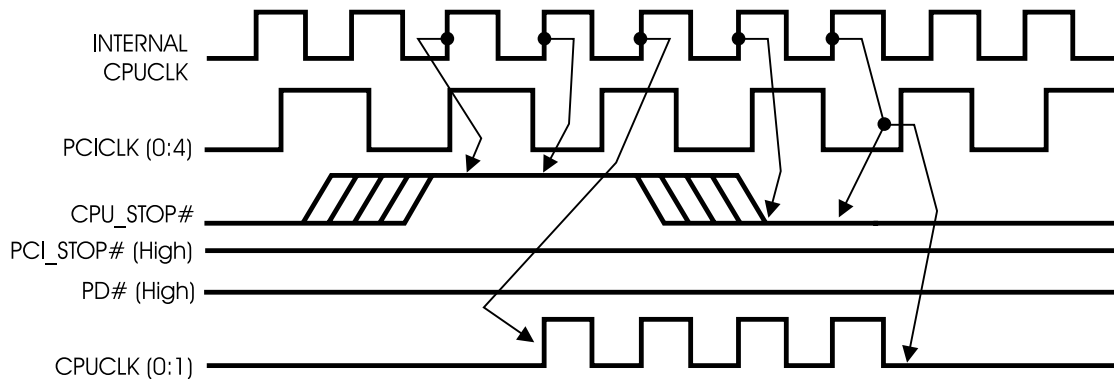

Fig. 1



## CPU\_STOP# Timing Diagram

CPUSTOP# is an asynchronous input to the clock synthesizer. It is used to turn off the CPUCLKs for low power operation. CPU\_STOP# is synchronized by the **ICS9248-157**. The minimum that the CPUCLK is enabled (CPU\_STOP# high pulse) is 100 CPUCLKs. All other clocks will continue to run while the CPUCLKs are disabled. The CPUCLKs will always be stopped in a low state and start in such a manner that guarantees the high pulse width is a full pulse. CPUCLK on latency is less than 4 CPUCLKs and CPUCLK off latency is less than 4 CPUCLKs.



### Notes:

1. All timing is referenced to the internal CPUCLK.
2. CPU\_STOP# is an asynchronous input and metastable conditions may exist. This signal is synchronized to the CPUCLKs inside the **ICS9248-157**.
3. All other clocks continue to run undisturbed.
4. PD# and PCI\_STOP# are shown in a high (true) state.





## PCI\_STOP# Timing Diagram

PCI\_STOP# is an asynchronous input to the **ICS9248-157**. It is used to turn off the PCICLK clocks for low power operation. PCI\_STOP# is synchronized by the **ICS9248-157** internally. The minimum that the PCICLK clocks are enabled (PCI\_STOP# high pulse) is at least 10 PCICLK clocks. PCICLK clocks are stopped in a low state and started with a full high pulse width guaranteed. PCICLK clock on latency cycles are only one rising PCICLK clock off latency is one PCICLK clock.

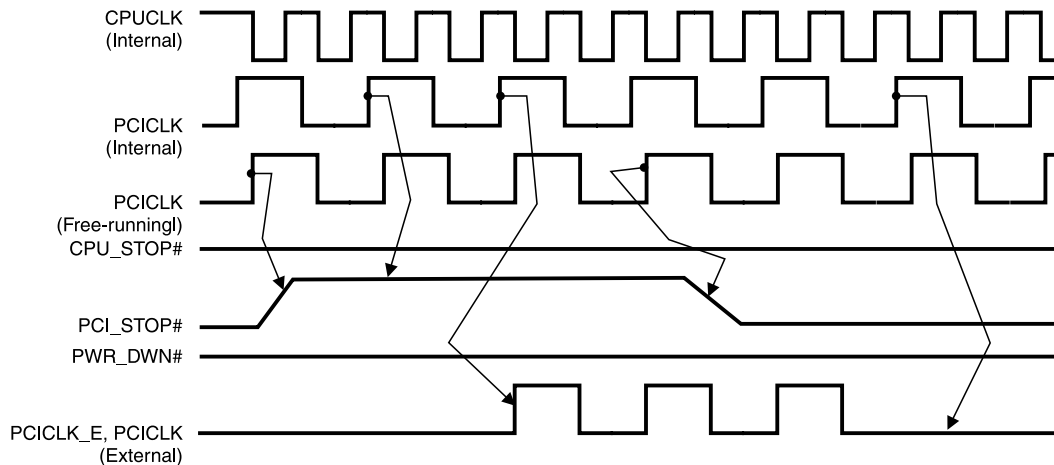

### Notes:

1. All timing is referenced to the Internal CPUCLK (defined as inside the ICS9248 device.)
2. PCI\_STOP# is an asynchronous input, and metastable conditions may exist. This signal is required to be synchronized inside the ICS9248.
3. All other clocks continue to run undisturbed.
4. PD# and CPU\_STOP# are shown in a high (true) state.



## PD# Timing Diagram

The power down selection is used to put the part into a very low power state without turning off the power to the part. PD# is an asynchronous active low input. This signal is synchronized internally by the **ICS9248-157** prior to its control action of powering down the clock synthesizer. Internal clocks will not be running after the device is put in power down state. When PD# is active (low) all clocks are driven to a low state and held prior to turning off the VCOs and the crystal oscillator. The power on latency is guaranteed to be less than 3ms. The power down latency is less than three CPUCLK cycles. PCI\_STOP# and CPU\_STOP# are don't care signals during the power down operations.

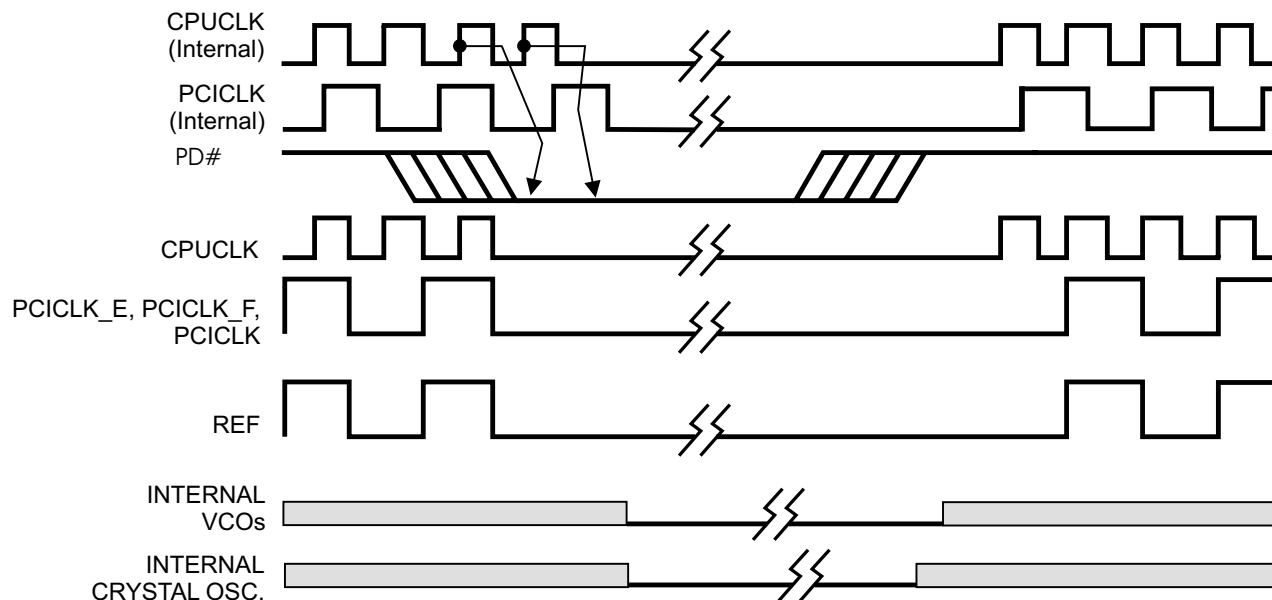

### Notes:

1. All timing is referenced to the Internal CPUCLK (defined as inside the ICS9248 device).
2. PD# is an asynchronous input and metastable conditions may exist. This signal is synchronized inside the ICS9248.
3. The shaded sections on the VCO and the Crystal signals indicate an active clock is being generated.

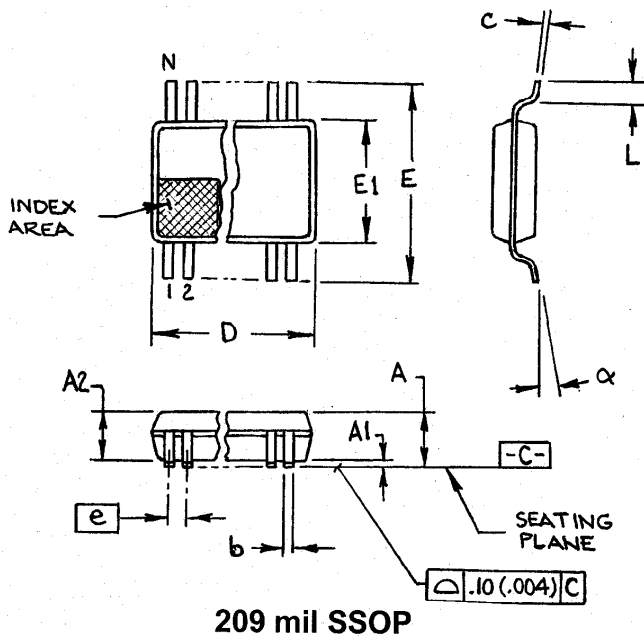

SYMBOL	In Millimeters COMMON DIMENSIONS		In Inches COMMON DIMENSIONS	
	MIN	MAX	MIN	MAX
A	-	2.00	-	.079
A1	0.05	-	.002	-
A2	1.65	1.85	.065	.073
b	0.22	0.38	.009	.015
c	0.09	0.25	.0035	.010
D	SEE VARIATIONS		SEE VARIATIONS	
E	7.40	8.20	.291	.323
E1	5.00	5.60	.197	.220
e	0.65 BASIC		0.0256 BASIC	
L	0.55	0.95	.022	.037
N	SEE VARIATIONS		SEE VARIATIONS	
$\alpha$	0°	8°	0°	8°

VARIATIONS

N	D mm.		D (inch)	
	MIN	MAX	MIN	MAX
28	9.90	10.50	.390	.413

MO-150 JEDEC 67 1/00 Rev B  
Doc. # 10-0033

### Ordering Information

ICS9248yF-157-T

Example:

**ICS XXXX y F - PPP - T**

