

BUFFER/CLOCK DRIVER

ICSLV810

Description

The ICSLV810 is a low skew 1.5 V to 2.5 V, 1:10 fanout buffer. This device is specifically designed for data communications clock management. The large fanout from a single input line reduces loading on the input clock. The TTL level outputs reduce noise levels on the part. Typical applications are clock and signal distribution.

Features

- Packaged in 20-pin QSOP/SSOP
- Split 1:10 fanout Buffer
- Maximum skew between outputs of different packages 0.75 ns
- Max propagation delay of 3.8 ns
- Operating voltage of 1.5 V to 2.5 V on Bank A
- Operating voltage of 1.5 V to 2.5 V on Banks B and C
- Advanced, low power, CMOS process
- Industrial temperature range -40° C to +85° C
- 3.3 V tolerant input when VDDA=2.5 V
- Pb (lead) free packaging

Block Diagram

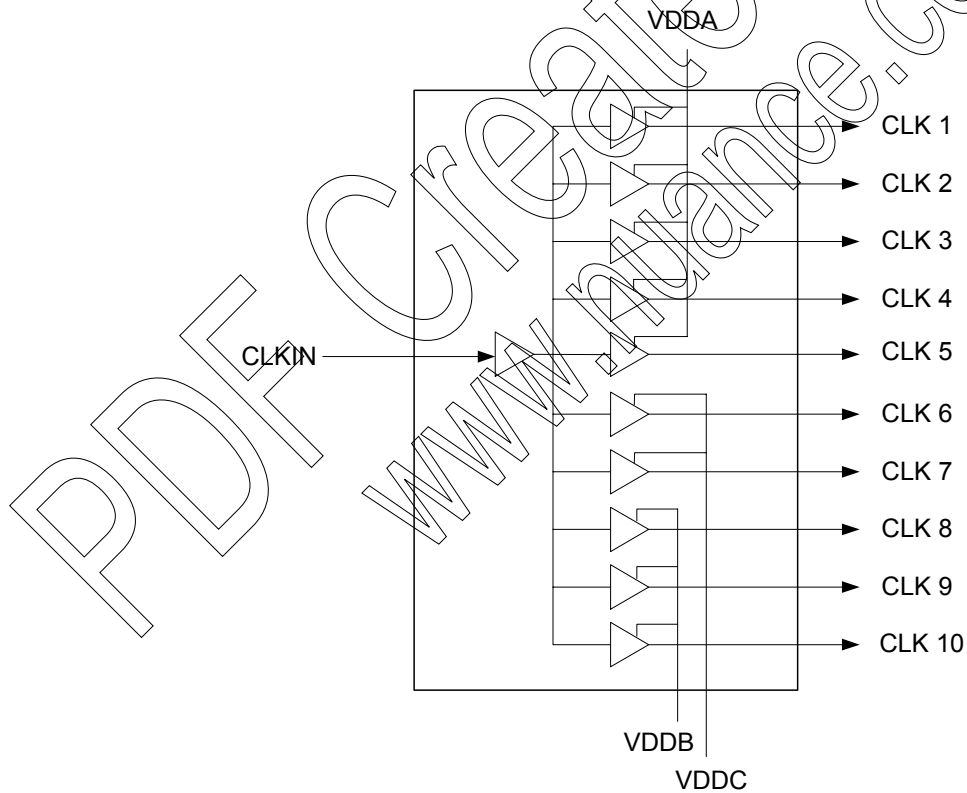

Pin Assignment

CLKIN	1	20	VDDB
GND	2	19	CLK 10
CLK 1	3	18	CLK 9
VDDA	4	17	GND
CLK 2	5	16	CLK 8
GND	6	15	VDDC
CLK 3	7	14	CLK 7
VDDA	8	13	GND
CLK 4	9	12	CLK 6
GND	10	11	CLK 5

20 pin (150mil) SSOP

Pin Descriptions

Pin Number	Pin Name	Pin Type	Pin Description
1	CLKIN	Input	Clock input.
2	GND	Power	Connect to ground.
3	CLK1	Output	Clock output.
4	VDDA	Power	Connect to +1.5 - +2.5 V.
5	CLK2	Output	Clock output.
6	GND	Power	Connect to ground.
7	CLK3	Output	Clock output.
8	VDDA	Power	Connect to +1.5 - +2.5 V.
9	CLK4	Output	Clock output.
10	GND	Power	Connect to ground.
11	CLK5	Output	Clock output.
12	CLK6	Output	Clock output.
13	GND	Power	Connect to ground.
14	CLK7	Output	Clock output.
15	VDDC	Power	Connect to +1.5 - 2.5 V.
16	CLK8	Output	Clock output.
17	GND	Power	Connect to ground.
18	CLK9	Output	Clock output.
19	CLK10	Output	Clock output.
20	VDDB	Power	Connect to +1.5 - 2.5 V.

External Components

The ICSLV810 requires a minimum number of external components for proper operation.

Decoupling Capacitors

Decoupling capacitors of 0.01 μ F must be connected between VDD and GND, as close to these pins as possible. For optimum device performance, the decoupling capacitors should be mounted on the component side of the PCB. Avoid the use of vias in the decoupling circuit.

Series Termination Resistor

When the PCB trace between the clock outputs and the loads are over 1 inch, series termination should be used. To series terminate a 50 Ω trace (a commonly used trace impedance) place a 33 Ω resistor in series with the clock line,

as close to the clock output pin as possible. The nominal impedance of the clock output is 20 Ω .

PCB Layout Recommendations

For optimum device performance and lowest output phase noise, the following guidelines should be observed.

- 1) The 0.01 μ F decoupling capacitors should be mounted on the component side of the board as close to the VDD pins as possible. No vias should be used between the decoupling capacitors and VDD pins. The PCB trace to VDD pin should be kept as short as possible, as should the PCB trace to the ground via.
- 2) To minimize EMI the 33 Ω series termination resistor, if needed, should be placed close to the clock output.

Absolute Maximum Ratings

Stresses above the ratings listed below can cause permanent damage to the ICSLV810. These ratings, which are standard values for ICS commercially rated parts, are stress ratings only. Functional operation of the device at these or any other conditions above those indicated in the operational sections of the specifications is not implied. Exposure to absolute maximum rating conditions for extended periods can affect product reliability. Electrical parameters are guaranteed only over the recommended operating temperature range.

Item	Rating
Supply Voltage, VDD MAX	7 V
All Inputs and Outputs	-0.5 V to VDDA + 1.2 V
Ambient Operating Temperature	-40 to +85° C
Storage Temperature	-65 to +150° C
Junction Temperature	125° C
Soldering Temperature	260° C

Recommended Operation Conditions

Parameter	Min.	Typ.	Max.	Units
Ambient Operating Temperature	-40		+85	°C
Power Supply Voltage (measured with respect to GND), VDDA	1.425		2.625	V
Power Supply Voltage (measured with respect to GND), VDDB	1.425		2.625	V
Power Supply Voltage (measured with respect to GND), VDDC	1.425		2.625	V

DC Electrical Characteristics—CLKIN and Bank A

VDDA = 2.5 V, Ambient Temperature -40° C to +85° C

Parameter	Symbol	Conditions	Min.	Typ.	Max.	Units
Operating Voltage	VDDA		1.425		2.625	V
Quiescent Power Supply Current	IDDA	No Load F = 40 MHz		15		mA
Short Circuit Current	I _{OS}	CLK 1 - 5		±80		mA
Input High Voltage, CLKIN	V _{IH}	Guaranteed Logic Level High	1.6			V
Input Low Voltage, CLKIN	V _{IL}	Guaranteed Logic Level Low			0.8	V
Output High Voltage	V _{OH}	V _{IN} = V _{IH} or V _{IL} I _{OH} = -7 mA	1.8			V
Output Low Voltage	V _{OL}	V _{IN} = V _{IH} or V _{IL} I _{OL} = 12 mA			0.4	V
Input High Current	I _{IH}	VDD = max V _{IN} = 2.4 V			1	μA
Input Low Current	I _{IL}	VDD = max V _{IN} = 0.5 V			-1	μA
Input High Current	I _I	VDD = max V _{IN} = VDD (max)			20	μA
Input Capacitance	C _{IN}	V _{IN} = 0V, Note1		5	6.0	pF
Output Capacitance	C _{OUT}	V _{OUT} = 0V, Note1		5.5	8.0	pF

Note1: This parameter is not tested, guaranteed by design.

DC Electrical Characteristics—Bank B

VDDB = 2.5 V, Ambient Temperature -40° C to +85° C, unless otherwise noted

Parameter	Symbol	Conditions	Min.	Typ.	Max.	Units
Operating Voltage	VDDB		1.425		2.625	V
Quiescent Power Supply Current	IDDB	VDDB = 2.5 V No Load F = 40 MHz		7m		A
		VDDB = 1.5 V No Load F = 40 MHz		3m		A
Short Circuit Current	I _{OS}	VDDB = 1.5 V CLK8-10		±35		mA
		VDDB = 2.5 V CLK8-10		±80		mA

Parameter	Symbol	Conditions	Min.	Typ.	Max.	Units	
Output High Voltage	V_{OH}	$V_{DDB} = 1.5\text{ V}$ $V_{IN} = V_{IH}$ or V_{IL}	$I_{OH} = -7\text{ mA}$	1.1			V
		$V_{DDB} = 2.5\text{ V}$ $V_{IN} = V_{IH}$ or V_{IL}	$I_{OH} = -7\text{ mA}$	1.8			V
Output Low Voltage	V_{OL}	$V_{DDB} = 1.5\text{ V}$ $V_{IN} = V_{IH}$ or V_{IL}	$I_{OL} = 12\text{ mA}$			0.42	V
		$V_{DDB} = 2.5\text{ V}$ $V_{IN} = V_{IH}$ or V_{IL}	$I_{OL} = 12\text{ mA}$			0.4	V
Input High Current	I_{IH}	$V_{DDB} = \text{max}$			1	μA	
Input Low Current	I_{IL}	$V_{DDB} = \text{max}$			-1	μA	
Input High Current	I_I	$V_{DDB} = \text{max}$, $V_{IN} = V_{DD}$ (max)			20	μA	
Input Capacitance	C_{IN}	$V_{IN} = 0\text{ V}$, Note 1		5	6.0	pF	
Output Capacitance	C_{OUT}	$V_{OUT} = 0\text{ V}$, Note 1		5.5	8.0	pF	

Note1: This parameter is not tested, guaranteed by design.

DC Electrical Characteristics—Bank C

$V_{DDC} = 2.5\text{ V}$, Ambient Temperature -40° C to $+85^\circ\text{ C}$, unless otherwise noted

Parameter	Symbol	Conditions	Min.	Typ.	Max.	Units	
Operating Voltage	V_{DDC}		1.425		2.625	V	
Quiescent Power Supply Current	I_{DDC}	$V_{DDC} = 2.5\text{ V}$ No Load $F = 40\text{ MHz}$		3m		A	
		$V_{DDC} = 1.5\text{ V}$ No Load $F = 40\text{ MHz}$		2m		A	
Short Circuit Current	I_{OS}	$V_{DDC} = 1.5\text{ V}$ CLK6-7		± 35		mA	
		$V_{DDC} = 2.5\text{ V}$ CLK6-7		± 80		mA	
Output High Voltage	V_{OH}	$V_{DDC} = 1.5\text{ V}$ $V_{IN} = V_{IH}$ or V_{IL}	$I_{OH} = -7\text{ mA}$	1.1		V	
		$V_{DDC} = 2.5\text{ V}$ $V_{IN} = V_{IH}$ or V_{IL}	$I_{OH} = -7\text{ mA}$	1.8		V	
Output Low Voltage	V_{OL}	$V_{DDC} = 1.5\text{ V}$ $V_{IN} = V_{IH}$ or V_{IL}	$I_{OL} = 12\text{ mA}$			0.42	V
		$V_{DDC} = 2.5\text{ V}$ $V_{IN} = V_{IH}$ or V_{IL}	$I_{OL} = 12\text{ mA}$			0.4	V
Input High Current	I_{IH}	$V_{DDC} = \text{max}$			1	μA	
Input Low Current	I_{IL}	$V_{DDC} = \text{max}$			-1	μA	

Parameter	Symbol	Conditions	Min.	Typ.	Max.	Units
Input High Current	I _I	V _{DDC} = max, V _{IN} = V _{DD} (max)			20	μA
Input Capacitance	C _{IN}	V _{IN} = 0V, Note1		5	6.0	pF
Output Capacitance	C _{OUT}	V _{OUT} = 0V, Note 1		5.5	8.0	pF

Note1: This parameter is not tested, guaranteed by design.

AC Electrical Characteristics—Bank A

V_{DDA} = 2.5 V, Ambient Temperature -40° C to +85° C

Parameter	Symbol	Conditions	Min.	Typ.	Max.	Units
Output Skew: skew between outputs of same package	t _{sk(o)}	CL = 3 pF, RL = 500Ω Figure 3	-200		200	ps
Pulse Skew: skew between opposite transitions of same output (t _{PLH} -t _{PHL})	t _{sk(p)}	CL = 3 pF, RL = 500Ω Figure 4	-200		200	ps
Propagation Delay	t _{pLH} / t _{pHL}	CL = 3 pF, RL = 500Ω Figure 2	1.5	2.6	3.5	ns
Part to Part Skew	t _{sk(t)}	CL = 3 pF, RL = 500Ω Figure 5	-650		650	ps
Output Rise Time 20% to 80%	t _{r(o)}	CL = 3 pF, RL = 500Ω		0.8		ns
Output Fall Time 80% to 20%	t _{f(o)}	CL = 3 pF, RL = 500Ω		0.8		ns
Additive Jitter	t _j	All Outputs			50	ps
Duty Cycle Measured at V _{DD} /2	DC	CL = 3 pF, RL = 500Ω	45		55	%
Duty Cycle, V _{DDA} =1.8V	DC		40	50	60	%
Output Frequency Range			1		133	MHz

AC Electrical Characteristics—Bank B

VDDB = 2.5 V, Ambient Temperature -40° C to +85° C, unless otherwise noted

Parameter	Symbol	Conditions	Min.	Typ.	Max.	Units
Output Skew: skew between outputs of same package	$t_{sk(o)C}$	$L = 3 \text{ pF}$, $R_L = 500\Omega$ Figure 3	-200		200	ps
Pulse Skew: skew between opposite transitions of same output (tPLH-tPHL)	$t_{sk(P)}$	$C_L = 3 \text{ pF}$, $R_L = 500\Omega$ Figure 4	-200		200	ps
Propagation Delay	t_{pLH} / t_{pHL}	$C_L = 3 \text{ pF}$, $R_L = 500\Omega$, VDDB = 1.5 V Figure 2		5.5		ns
		$C_L = 3 \text{ pF}$, $R_L = 500\Omega$, VDDB = 2.5 V Figure 2	1.5	2.6	3.5	ns
Part to Part Skew		$C_L = 3 \text{ pF}$, $R_L = 500\Omega$ VDDB = 1.5 V Figure 5	-1		1	ns
		$C_L = 3 \text{ pF}$, $R_L = 500\Omega$ VDDB = 2.5 V Figure 5	-650		650	ps
Output Rise Time 20% to 80%	$t_{r(o)}$	$C_L = 3 \text{ pF}$, $R_L = 500\Omega$ VDDB = 1.5 V		1.0		ns
		$C_L = 3 \text{ pF}$, $R_L = 500\Omega$ VDDB = 2.5 V		0.8		ns
Output Fall Time 80% to 20%	$t_{f(o)}$	$C_L = 3 \text{ pF}$, $R_L = 500\Omega$ VDDB = 1.5 V		1.0		ns
		$C_L = 3 \text{ pF}$, $R_L = 500\Omega$ VDDB = 2.5 V		0.8		ns
Additive Jitter	t_j	All Outputs, VDDB = 1.5 V			34	ps
		All Outputs, VDDB = 2.5 V			50	ps
Duty Cycle Measured at VDD/2	DC	$C_L = 3 \text{ pF}$, $R_L = 500\Omega$	45		55	%
Duty Cycle, VDDB = 1.8V	DC		40	50	60	%
Output Frequency Range			1		133	MHz

AC Electrical Characteristics—Bank C

VDDC = 2.5 V, Ambient Temperature -40° C to +85° C, unless otherwise noted

Parameter	Symbol	Conditions	Min.	Typ.	Max.	Units
Output Skew: skew between outputs of same package	$t_{SK(O)C}$	$L = 3 \text{ pF}$, $R_L = 500\Omega$ Figure 3	-200		200	ps
Pulse Skew: skew between opposite transitions of same output (tPLH-tPHL)	$t_{SK(P)}$	$C_L = 3 \text{ pF}$, $R_L = 500\Omega$ Figure 4	-200		200	ps
Propagation Delay	t_{pLH} / t_{pHL}	$C_L = 3 \text{ pF}$, $R_L = 500\Omega$, VDDC = 1.5 V Figure 2		5.5		ns
		$C_L = 3 \text{ pF}$, $R_L = 500\Omega$, VDDC = 2.5 V Figure 2	1.5	2.6	3.5	ns
Part to Part Skew		$C_L = 3 \text{ pF}$, $R_L = 500\Omega$ VDDC = 1.5 V Figure 5	-1		1	ns
		$C_L = 3 \text{ pF}$, $R_L = 500\Omega$ VDDC = 2.5 V Figure 5	-650		650	ps
Output Rise Time 20% to 80%	$t_{r(o)}$	$C_L = 3 \text{ pF}$, $R_L = 500\Omega$ VDDC = 1.5 V		1.0		ns
		$C_L = 3 \text{ pF}$, $R_L = 500\Omega$ VDDC = 2.5 V		0.8		ns
Output Fall Time 80% to 20%	$t_{f(o)}$	$C_L = 3 \text{ pF}$, $R_L = 500\Omega$ VDDC = 1.5 V		1.0		ns
		$C_L = 3 \text{ pF}$, $R_L = 500\Omega$ VDDC = 2.5 V		0.8		ns
Additive Jitter	t_j	All Outputs, VDDC = 1.5 V			34	ps
		All Outputs, VDDC = 2.5 V			50	ps
Duty Cycle Measured at VDD/2	DC	$C_L = 3 \text{ pF}$, $R_L = 500\Omega$	45		55	%
Duty Cycle, VDDC=1.8V	DC		40	50	60	%
Output Frequency Range			1		133	MHz

Thermal Characteristics for 20QSOP

Parameter	Symbol	Conditions	Min.	Typ.	Max.	Units
Thermal Resistance Junction to Ambient	θ_{JA}	Still air		135		°C/W
	θ_{JA}	1 m/s air flow		93		°C/W
	θ_{JA}	3 m/s air flow		78		°C/W
Thermal Resistance Junction to Case	θ_{JC}			60		°C/W

Thermal Characteristics for 20SOIC

Parameter	Symbol	Conditions	Min.	Typ.	Max.	Units
Thermal Resistance Junction to Ambient	θ_{JA}	Still air		83		°C/W
	θ_{JA}	1 m/s air flow		71		°C/W
	θ_{JA}	3 m/s air flow		58		°C/W
Thermal Resistance Junction to Case	θ_{JC}			46		°C/W

PDF Create @ www.nuance.com

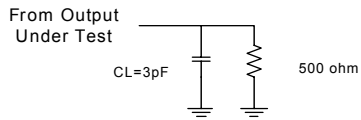

Figure 1. Load Circuit

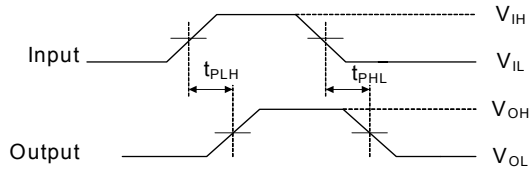

Figure 2. Propagation Delay

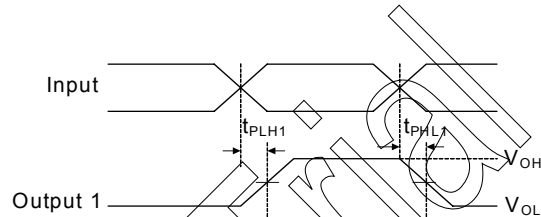
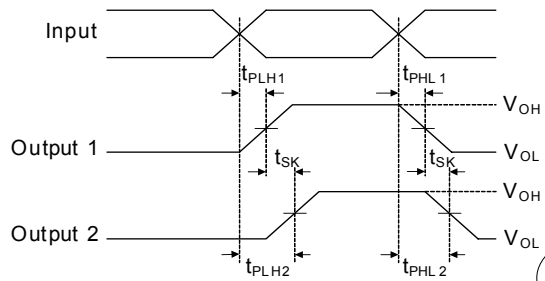
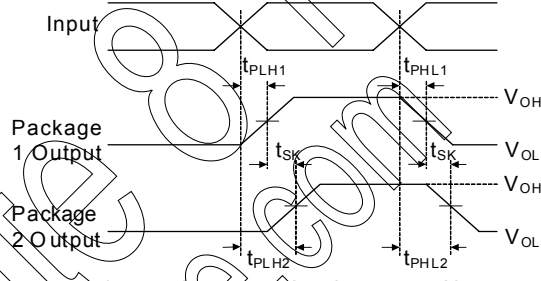

Figure 4. Pulse Skew ($t_{sk(p)} = |t_{pLH} - t_{pHL}|$)



($t_{sk(o)} = |t_{pLH2} - t_{pHL2}|$ or $|t_{pLH1} - t_{pHL1}|$)

Figure 3. Output Skew



($t_{sk(o)} = |t_{pLH2} - t_{pHL2}|$ or $|t_{pLH1} - t_{pHL1}|$)

Figure 5. Part-to-Part Skew

PDF Creator
 www.nuance.com

Package Outline and Package Dimensions (20-pin QSOP, 150 Mil. Body)

Package dimensions are kept current with JEDEC Publication No. 95

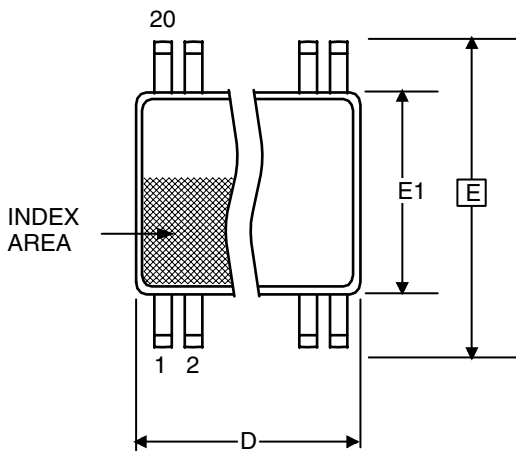

Symbol	Millimeters		Inches*	
	Min	Max	Min	Max
A	1.351	.75	.053	.069
A1	0.10	0.25	.0040	.010
A2	--	1.50	--	.059
b	0.20	0.30	0.008	0.012
C	0.180	.25	.007	.010
D	8.558	.75	.337	.344
E	5.806	.20	.228	.244
E1	3.80	4.00	.150	.157
e	0.635 Basic		0.025 Basic	
L	0.401	.27	.016	.050
α	0°	8°	0°	8°

*For reference only. Controlling dimensions in mm.

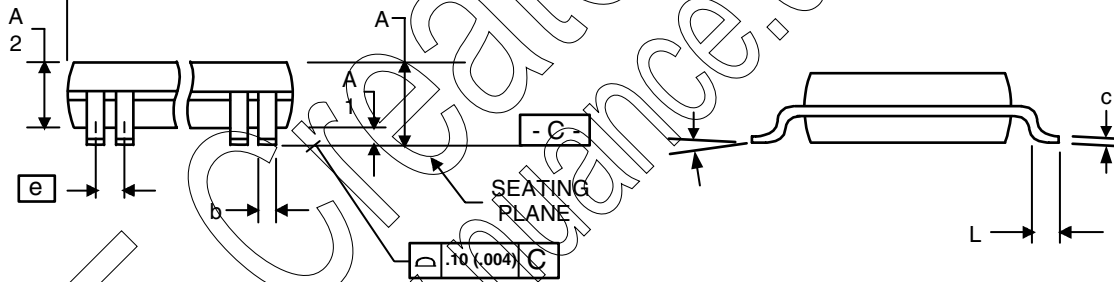

Package Outline and Package Dimensions (20-pin SSOP, 209 Mil. Body)

Package dimensions are kept current with JEDEC Publication No. 95

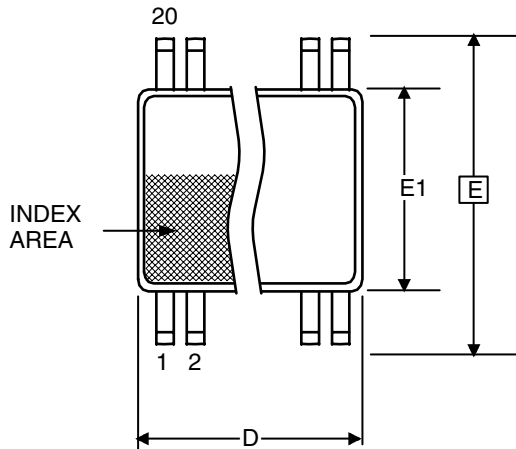

Symbol	Millimeters		Inches*	
	Min	Max	Min	Max
A	—	2.00	—	.079
A1	0.05	—	.002	—
A2	1.65	1.85	.065	.073
b	0.22	0.38	0.009	0.015
c	0.09	0.25	.0035	.010
D	6.907	.50	.271	.295
E	7.408	.20	.291	.323
E1	5.00	5.60	.197	.220
e	0.65 Basic		0.0256 Basic	
L	0.550	.95	.022	.037
α	0°	8°	0°	8°

*For reference only. Controlling dimensions in mm.

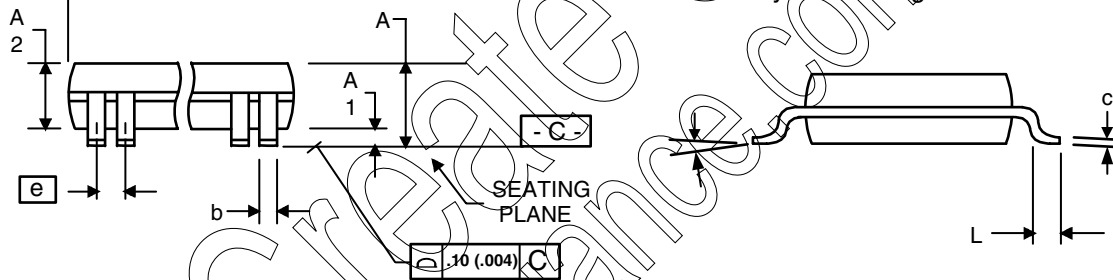

Ordering Information

Part / Order Number	Marking	Shipping Packaging	Package	Temperature
LV810RILF	LV810RILF	Tubes	20-pin QSOP	-40 to +85° C
LV810RILFT	LV810RILF	Tape and Reel	20-pin QSOP	-40 to +85° C
LV810FILF	LV810FILF	Tubes	20-pin SSOP	-40 to +85° C
LV810FILFT	LV810FILF	Tape and Reel	20-pin SSOP	-40 to +85° C

NOTE: EOL for non-green parts to occur on 5/13/10 per PDN U-09-01

"LF" suffix to the part number are the Pb-Free configuration and are RoHS compliant.

While the information presented herein has been checked for both accuracy and reliability, Integrated Device Technology (IDT) assumes no responsibility for either its use or for the infringement of any patents or other rights of third parties, which would result from its use. No other circuits, patents, or licenses are implied. This product is intended for use in normal commercial applications. Any other applications such as those requiring extended temperature range, high reliability, or other extraordinary environmental requirements are not recommended without additional processing by IDT. IDT reserves the right to change any circuitry or specifications without notice. IDT does not authorize or warrant any IDT product for use in life support devices or critical medical instruments.

Revision History

Rev.	Originator	Date	Description of Change
A	P.Griffith	03/25/05	New device/datasheet.
B	P.Griffith	05/02/05	Released from Preliminary to final; changed Short Circuit Current parameter in 2.5 V DC Char table to ± 80 mA; changed Short Circuit Current parameter in 1.5 V DC Char table to ± 35 mA
C	P.Griffith	05/12/05	Added bullet in "Features" for operating voltage of 2.5 V on Bank A and specified that operating voltages of 1.5 and 2.5 V are on Banks B and C; changed block diagram input and pin 1 from IN to CLKIN; removed +1.5 V spec from pin 4 and pin 8 descriptions; added "VDDA + 1.2 V" to "All Inputs and Outputs" section of Absolute Maximum Ratings; added min and max values for Banks A, B, and C "Power Supply Voltage" in Recommended Operating Conditions; expanded DC Electrical Char tables in to include a separate table for Banks A, B, and C; expanded AC Electrical Char tables in to include a separate table for Banks A, B, and C;
D	P.Griffith	06/21/05	Added 209 mil 20-pin SSOP package and ordering info.
E	K. Beckmeyer	07/27/05	Specified operating voltage on Bank A from 1.5V to 2.5V; Added figures 4 and 5 on page 10 to explain Pulse Skew and Part-to-Part Skew; Changed Output Frequency Max Specification to 133MHz in AC Electrical Char tables for Banks A, B, and C; Added Duty Cycle Spec for VDD = 1.5V in AC Electrical Char tables for Banks A, B, C; Changed CLK conditions in DC Electrical Char tables on Banks B and C; removed SOIC package.
F	K. Beckmeyer	10/13/05	Added "LF" packaging and ordering info to both "R" and "F" packages.
G		12/17/09	Added EOL note for non-green parts.
H		05/13/10	Removed EOL note and non-green orderables.

PDF Create & Trial
www.nuance.com

Innovate with IDT and accelerate your future networks. Contact:

www.IDT.com

For Sales

800-345-7015
408-284-8200
Fax: 408-284-2775

For Tech Support

www.idt.com/go/clockhelp

Corporate Headquarters

Integrated Device Technology, Inc.
www.idt.com



www.IDT.com