



25-Bit Configurable Registered Buffer

Recommended Application:

- DDR2 Memory Modules
- Provides complete DDR DIMM logic solution with ICS97U877

Product Features:

- 25-bit 1:1 or 14-bit 1:2 configurable registered buffer
- Supports SSTL_18 JEDEC specification on data inputs and outputs
- Supports LVCMOS switching levels on CSR# and RESET# inputs
- Low voltage operation
V_{DD} = 1.7V to 1.9V
- Available in 96 BGA package

Pin Configuration

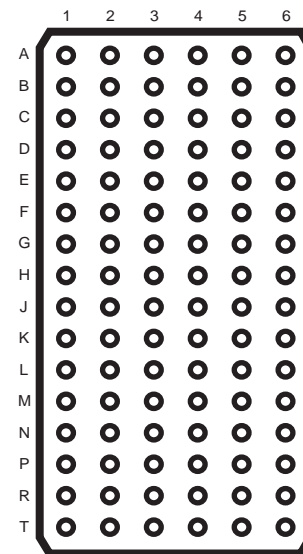

**96 Ball BGA
(Top View)**

Truth Table

Inputs						Outputs		
RST#	DCS#	CSR#	CK	CK#	Dn, DODT, DCKE	Qn	QCS#	QODT, QCKE
H	L	L	↑	↓	L	L	L	L
H	L	L	↑	↓	H	H	L	H
H	L	L	L or H	L or H	X	Q ₀	Q ₀	Q ₀
H	L	H	↑	↓	L	L	L	L
H	L	H	↑	↓	H	H	L	H
H	L	H	L or H	L or H	X	Q ₀	Q ₀	Q ₀
H	H	L	↑	↓	L	L	H	L
H	H	L	↑	↓	H	H	H	H
H	H	L	L or H	L or H	X	Q ₀	Q ₀	Q ₀
H	H	H	↑	↓	L	Q ₀	H	L
H	H	H	↑	↓	H	Q ₀	H	H
H	H	H	L or H	L or H	X	Q ₀	Q ₀	Q ₀
L	X or Floating	X or Floating	X or Floating	X or Floating	X or Floating	L	L	L

Ball Assignments

	DCKE	NC	V _{REF}	V _{DD}	QCKE	NC
A	D2	D15	GND	GND	Q2	Q15
B	D3	D16	V _{DD}	V _{DD}	Q3	Q16
C	DODT	NC	GND	GND	QODT	NC
D	D5	D17	V _{DD}	V _{DD}	Q5	Q17
E	D6	D18	GND	GND	Q6	Q18
F	NC	RST#	V _{DD}	V _{DD}	C1	C0
G	CK	DCS#	GND	GND	QCS#	NC
H	CK#	CSR#	V _{DD}	V _{DD}	ZOH	ZOL
J	D8	D19	GND	GND	Q8	Q19
K	D9	D20	V _{DD}	V _{DD}	Q9	Q20
L	D10	D21	GND	GND	Q10	Q21
M	D11	D22	V _{DD}	V _{DD}	Q11	Q22
N	D12	D23	GND	GND	Q12	Q23
P	D13	D24	V _{DD}	V _{DD}	Q13	Q24
R	D14	D25	V _{REF}	V _{DD}	Q14	Q25
T						
	1	2	3	4	5	6

1:1 Register (C0 = 0, C1 = 0)



Ball Assignments

A	DCKE	NC	V _{REF}	V _{DD}	QCKEA	QCKEB
B	D2	NC	GND	GND	Q2A	Q2B
C	D3	NC	V _{DD}	V _{DD}	Q3A	Q3B
D	DODT	NC	GND	GND	QODTA	QODTB
E	D5	NC	V _{DD}	V _{DD}	Q5A	Q5B
F	D6	NC	GND	GND	Q6A	Q6B
G	NC	RST#	V _{DD}	V _{DD}	C1	C0
H	CK	DCS#	GND	GND	QCSA#	QCSB#
J	CK#	CSR#	V _{DD}	V _{DD}	ZOH	ZOL
K	D8	NC	GND	GND	Q8A	Q8B
L	D9	NC	V _{DD}	V _{DD}	Q9A	Q9B
M	D10	NC	GND	GND	Q10A	Q10B
N	D11	NC	V _{DD}	V _{DD}	Q11A	Q11B
P	D12	NC	GND	GND	Q12A	Q12B
R	D13	NC	V _{DD}	V _{DD}	Q13A	Q13B
T	D14	NC	V _{REF}	V _{DD}	Q14A	Q14B
	1	2	3	4	5	6

1:2 Register A (C0 = 0, C1 = 1)

Ball Assignments

A	D1	NC	V _{REF}	V _{DD}	Q1A	Q1B
B	D2	NC	GND	GND	Q2A	Q2B
C	D3	NC	V _{DD}	V _{DD}	Q3A	Q3B
D	D4	NC	GND	GND	Q4A	Q4B
E	D5	NC	V _{DD}	V _{DD}	Q5A	Q5B
F	D6	NC	GND	GND	Q6A	Q6B
G	NC	RST#	V _{DD}	V _{DD}	C1	C0
H	CK	DCS#	GND	GND	QCSA#	QCSB#
J	CK#	CSR#	V _{DD}	V _{DD}	ZOH	ZOL
K	D8	NC	GND	GND	Q8A	Q8B
L	D9	NC	V _{DD}	V _{DD}	Q9A	Q9B
M	D10	NC	GND	GND	Q10A	Q10B
N	DODT	NC	V _{DD}	V _{DD}	QODTA	QODTB
P	D12	NC	GND	GND	Q12A	Q12B
R	D13	NC	V _{DD}	V _{DD}	Q13A	Q13B
T	DCKE	NC	V _{REF}	V _{DD}	QCKEA	QCKEB
	1	2	3	4	5	6

1:2 Register B (C0 = 1, C1 = 1)

General Description

This 25-bit 1:1 or 14-bit 1:2 configurable registered buffer is designed for 1.7-V to 1.9-V VDD operation.

All clock and data inputs are compatible with the JEDEC standard for SSTL_18. The control inputs are LVCMOS. All outputs are 1.8-V CMOS drivers that have been optimized to drive the DDR-II DIMM load. **ICSSSTU32864** operates from a differential clock (CK and CK#). Data are registered at the crossing of CK going high, and CK# going low.

The C0 input controls the pinout configuration of the 1:2 pinout from A configuration (when low) to B configuration (when high). The C1 input controls the pinout configuration from 25-bit 1:1 (when low) to 14-bit 1:2 (when high).

The device supports low-power standby operation. When the reset input (RST#) is low, the differential input receivers are disabled, and undriven (floating) data, clock and reference voltage (VREF) inputs are allowed. In addition, when RST# is low all registers are reset, and all outputs are forced low. The LVCMOS RST# and Cn inputs must always be held at a valid logic high or low level. To ensure defined outputs from the register before a stable clock has been supplied, RST# must be held in the low state during power up.

In the DDR-II RDIMM application, RST# is specified to be completely asynchronous with respect to CK and CK#. Therefore, no timing relationship can be guaranteed between the two. When entering reset, the register will be cleared and the outputs will be driven low quickly, relative to the time to disable the differential input receivers. However, when coming out of reset, the register will become active quickly, relative to the time to enable the differential input receivers. As long as the data inputs are low, and the clock is stable during the time from the low-to-high transition of RST# until the input receivers are fully enabled, the design of the **ICSSSTU32864** must ensure that the outputs will remain low, thus ensuring no glitches on the output.

The device monitors both DCS# and CSR# inputs and will gate the Qn outputs from changing states when both DCS# and CSR# inputs are high. If either DCS# or CSR# input is low, the Qn outputs will function normally. The RST input has priority over the DCS# and CSR# control and will force the outputs low. If the DCS#-control functionality is not desired, then the CSR# input can be hardwired to ground, in which case, the setup-time requirement for DCS# would be the same as for the other D data inputs. Package options include 96-ball LFBGA (MO-205CC).

**Ball Assignment**

Terminal Name	Description	Electrical Characteristics
GND	Ground	Ground input
V _{DD}	Power supply voltage	1.8V nominal
V _{REF}	Input reference voltage	0.9V nominal
Z _{OH}	Reserved for future use	Input
Z _{OL}	Reserved for future use	Input
CK	Positive master clock input	Differential input
CK	Negative master clock input	Differential input
C0, C1	Configuration control inputs	LVC MOS inputs
RST#	Asynchronous reset input - resets registers and disables V _{REF} data and clock differential-input receivers	LVC MOS input
CSR#, DCS#	Chip select inputs - disables D1 - D24 outputs switching when both inputs are high	SSTL ₁₈ input
D1 - D25	Data input - clock in on the crossing of the rising edge of CK and the falling edge of CK#	SSTL ₁₈ input
DODT	The outputs of this register bit will not be suspended by the DCS# and CSR# control	SSTL ₁₈ input
DCKE	The outputs of this register bit will now be suspended by the DCS# and CSR# control	SSTL ₁₈ input
Q1 - Q25	Data outputs that are suspended by the DCS# and CSR# control	1.8V CMOS
QCS#	Data output that will not be suspended by the DCS# and CSR# control	1.8V CMOS
QODT	Data output that will not be suspended by the DCS# and CSR# control	1.8V CMOS
QCKE	Data output that will not be suspended by the DCS# and CSR# control	1.8V CMOS



Block Diagram for 1:1 mode (positive logic)

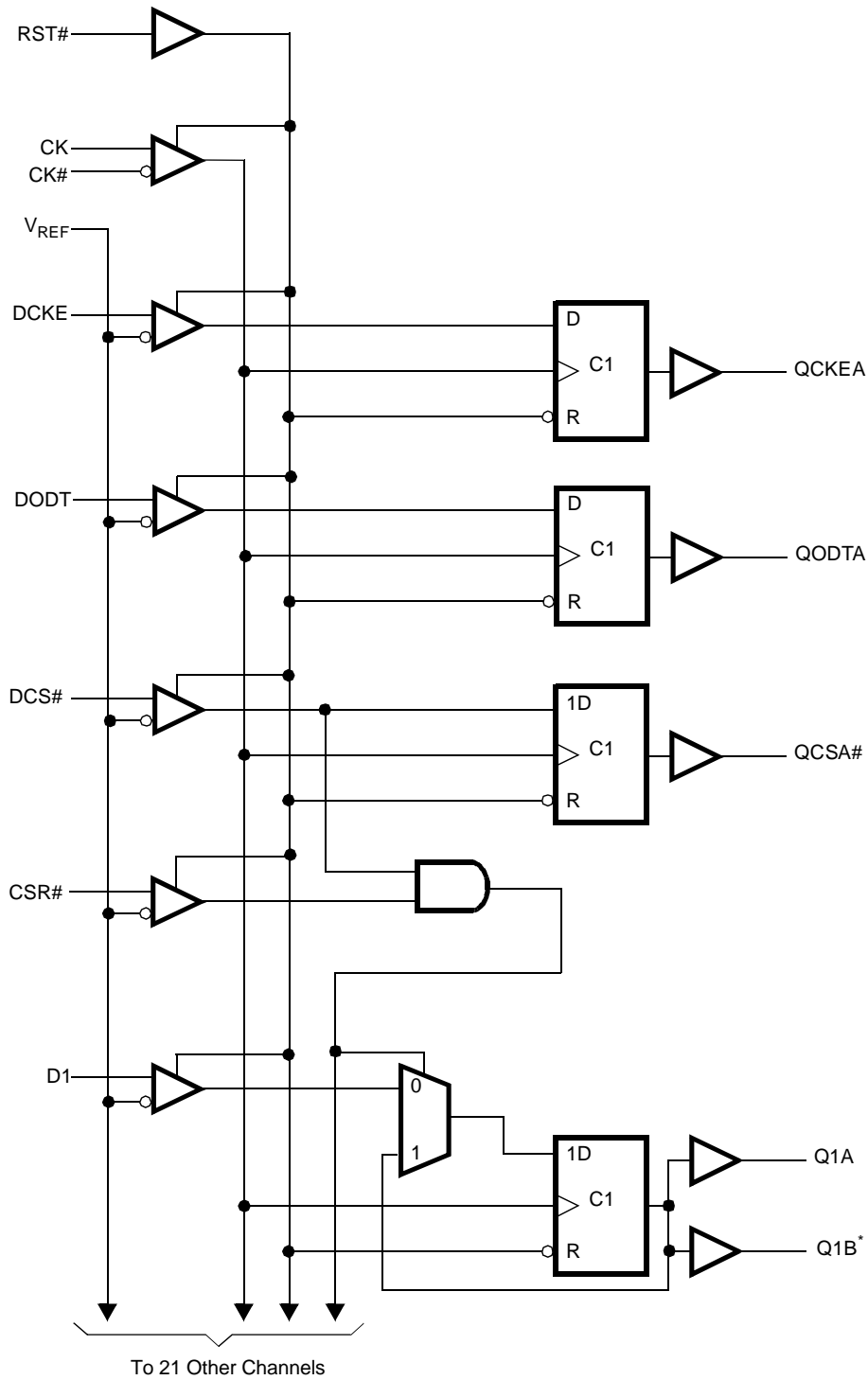



Block Diagram for 1:2 mode (positive logic)

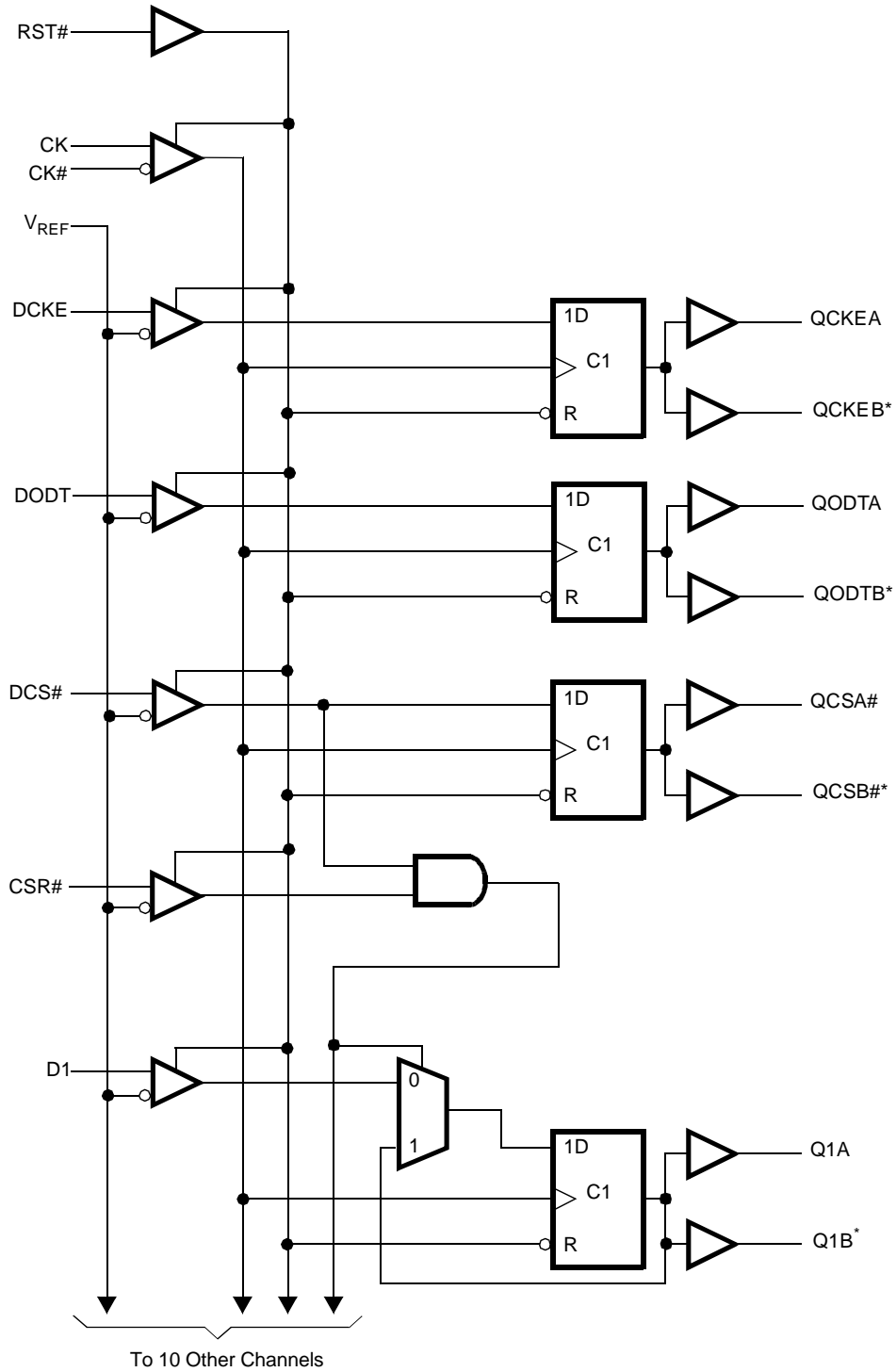

*Note: Disabled in 1:1 configuration



Absolute Maximum Ratings

Storage Temperature	-65°C to +150°C
Supply Voltage	-0.5 to 2.5V
Input Voltage ¹	-0.5 to VDD + 2.5V
Output Voltage ^{1,2}	-0.5 to VDDQ + 0.5
Input Clamp Current	±50 mA
Output Clamp Current	±50mA
Continuous Output Current	±50mA
VDDQ or GND Current/Pin	±100mA
Package Thermal Impedance ³	36°C

Notes:

1. The input and output negative voltage ratings may be excluded if the input and output clamp ratings are observed.
2. This current will flow only when the output is in the high state level $V_0 > V_{DDQ}$.
3. The package thermal impedance is calculated in accordance with JESD 51.

Stresses above those listed under *Absolute Maximum Ratings* may cause permanent damage to the device. These ratings are stress specifications only and functional operation of the device at these or any other conditions above those listed in the operational sections of the specifications is not implied. Exposure to absolute maximum rating conditions for extended periods may affect product reliability.

Recommended Operating Conditions

PARAMETER	DESCRIPTION		MIN	TYP	MAX	UNITS
V _{DDQ}	I/O Supply Voltage		1.7	1.8	1.9	V
V _{REF}	Reference Voltage		0.49 x V _{DD}	0.5 x V _{DD}	0.51 x V _{DD}	
V _{TT}	Termination Voltage		V _{REF} - 0.04	V _{REF}	V _{REF} + 0.04	
V _I	Input Voltage		0		V _{DDQ}	
V _{IH (DC)}	DC Input High Voltage	Data Inputs	V _{REF} + 0.125			
V _{IH (AC)}	AC Input High Voltage		V _{REF} + 0.250			
V _{IL (DC)}	DC Input Low Voltage				V _{REF} - 0.125	
V _{IL (DC)}	AC Input Low Voltage		V _{REF} + 0.250			
V _{IH}	Input High Voltage Level	RESET#, C0, C1	0.65 x V _{DDQ}			
V _{IL}	Input Low Voltage Level				0.35 x V _{DDQ}	
V _{ICR}	Common mode Input Range	CLK, CLK#	0.675		1.125	
V _{ID}	Differential Input Voltage		0.600			
I _{OH}	High-Level Output Current				-8	
I _{OL}	Low-Level Output Current				8	
T _A	Operating Free-Air Temperature		0		70	°C

¹Guaranteed by design, not 100% tested in production.

Note: Reset# and Cn inputs must be held at valid logic levels (not floating) to ensure proper device operation. The differential inputs must not be floating unless Reset# is low.



Electrical Characteristics - DC

$T_A = 0 - 70^\circ\text{C}$; $V_{DD} = 2.5 \pm 0.2\text{V}$, $V_{DDQ} = 2.5 \pm 0.2\text{V}$; (unless otherwise stated)

SYMBOL	PARAMETERS	CONDITIONS	V_{DDQ}	MIN	TYP	MAX	UNITS
V_{IK}		$I_I = -18\text{mA}$				-1.2	V
V_{OH}		$I_{OH} = -100\mu\text{A}$	1.7V - 1.9V	$V_{DDQ} - 0.2$			
		$I_{OH} = -16\text{mA}$	1.7V	1.95			
V_{OL}		$I_{OL} = 100\mu\text{A}$	1.7V - 1.9V			0.2	
		$I_{OL} = 16\text{mA}$	1.7V			0.35	
I_I	All Inputs	$V_I = V_{DD}$ or GND		1.9V		± 5	μA
I_{DD}	Standby (Static)	RESET# = GND	1.9V			0.01	μA
	Operating (Static)	$V_I = V_{IH(AC)}$ or $V_{IL(AC)}$, RESET# = V_{DD}			TBD		
I_{DDD}	Dynamic operating (clock only)	RESET# = V_{DD} , $V_I = V_{IH(AC)}$ or $V_{IL(AC)}$, CLK and CLK# switching 50% duty cycle.	1.8V		TBD		μ/clock MHz
	Dynamic Operating (per each data input)	RESET# = V_{DD} , $V_I = V_{IH(AC)}$ or $V_{IL(AC)}$, CLK and CLK# switching 50% duty cycle. One data input switching at half clock frequency, 50% duty cycle		$I_O = 0$		TBD	
r_{OH}	Output High	$I_{OH} = -20\text{mA}$					Ω
r_{OL}	Output Low	$I_{OL} = 20\text{mA}$					Ω
$r_{O(D)}$	[$r_{OH} - r_{OL}$] each separate bit	$I_O = 20\text{mA}$, $T_A = 25^\circ\text{C}$				4	Ω
C_i	Data Inputs	$V_I = V_{REF} \pm 350\text{mV}$		2.5		3.5	pF
	CLK and CLK#	$V_{ICR} = 1.25\text{V}$, $V_{I(PP)} = 360\text{mV}$		2		3	
	RESET#	$V_I = V_{DDQ}$ or GND			2.5		

Notes:

1 - Guaranteed by design, not 100% tested in production.



Timing Requirements

(over recommended operating free-air temperature range, unless otherwise noted)

SYMBOL	PARAMETERS		V _{DD} = 1.8V ±0.1V		UNITS
			MIN	MAX	
f _{clock}	Clock frequency			300	MHz
t _S	Setup time	Data before CLK↑, CLK#↓	0.75		ns
			0.9		ns
T _h	Hold time, fast slew rate ^{2, 4}	Data after CLK↑, CLK#↓	0.50		ns
	Hold time, slow slew rate ^{3, 4}		0.70		ns

- Notes:**
- 1 - Guaranteed by design, not 100% tested in production.
 - 2 - For data signal input slew rate of 1V/ns.
 - 3 - For data signal input slew rate of 0.5V/ns and < 1V/ns.
 - 4 - CLK/CLK# signal input slew rate of 1V/ns.

Switching Characteristics

(over recommended operating free-air temperature range, unless otherwise noted)

SYMBOL	From (Input)	To (Output)	V _{DD} = 1.8V ±0.1V			UNITS
			MIN	TYP	MAX	
f _{max}			270			MHz
t _{PDM} ¹	CLK, CLK#	Q	1.41		1.85	ns
t _{PDMSS} ²	CLK, CLK#	Q				
t _{phl}	RESET#	Q			3	ns

- Notes: 1. Includes 350ps test-load transmission-line delay
 2. Guaranteed by design, not 100% tested in production.

Output Buffer Characteristics

Output edge rates over recommended operating free-air temperature range (See figure 7)

PARAMETER	V _{DD} = 1.8V ± 0.1V		UNIT
	MIN	MAX	
dV/dt _r	1	4	V/ns
dV/dt _f	1	4	V/ns
dV/dt _Δ ¹		1	V/ns

1. Difference between dV/dt_r (rising edge rate) and dV/dt_f (falling edge rate)

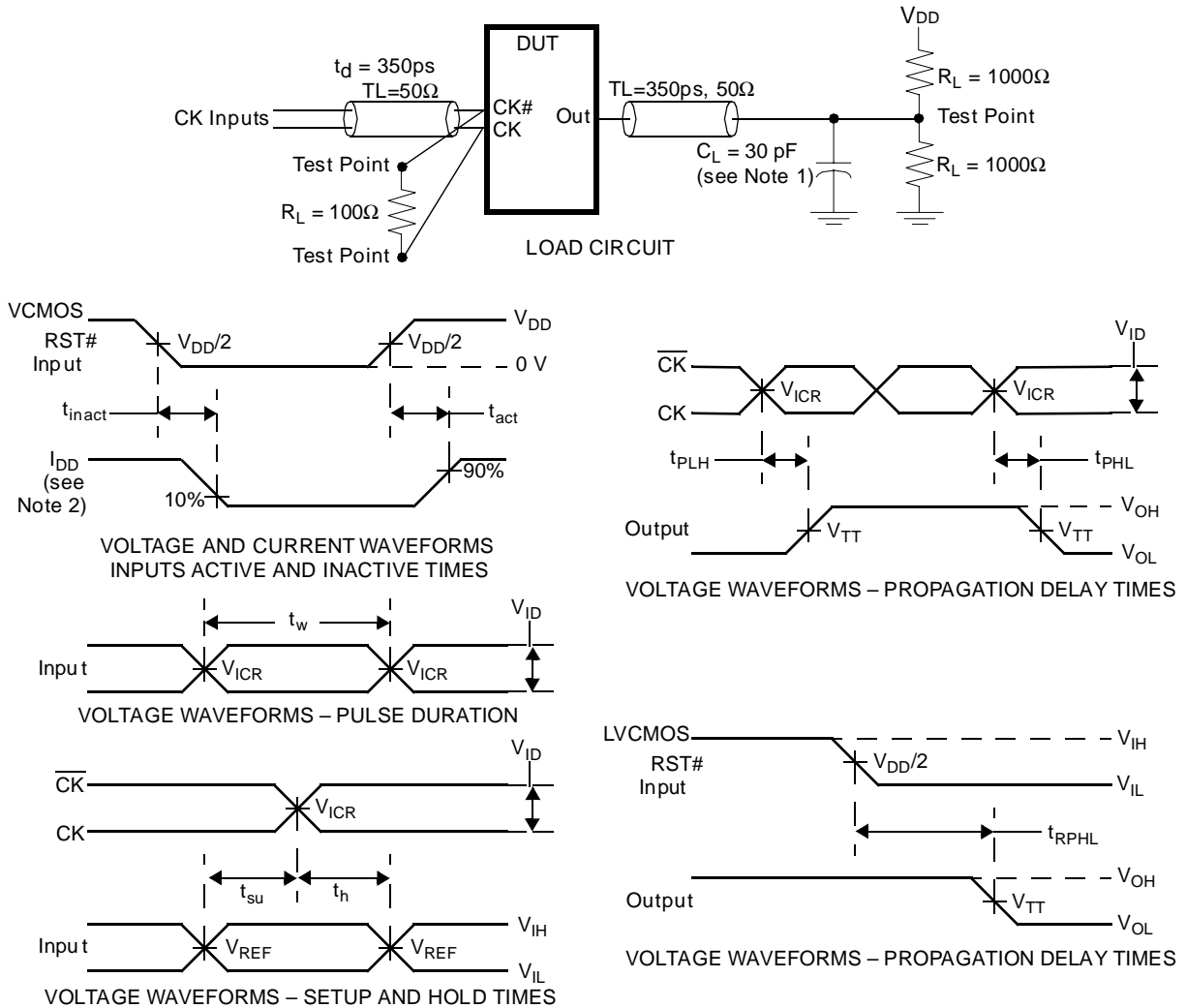
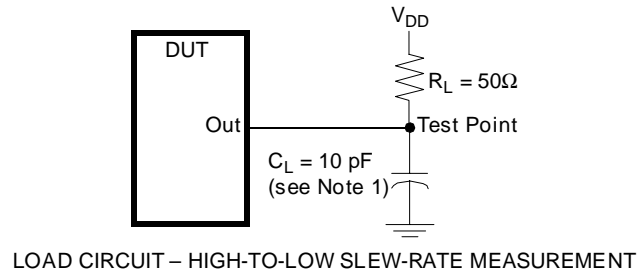
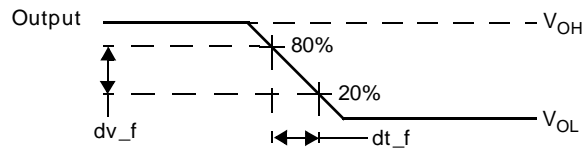

Figure 6 — Parameter Measurement Information ($V_{DD} = 1.8\text{ V} \pm 0.1\text{ V}$)

- Notes:
1. C_L includes probe and jig capacitance.
 2. I_{DD} tested with clock and data inputs held at V_{DD} or GND, and $I_o = 0\text{ mA}$.
 3. All input pulses are supplied by generators having the following characteristics: $PRR \leq 10\text{ MHz}$, $Z_o = 50\Omega$, input slew rate = $1\text{ V/ns} \pm 20\%$ (unless otherwise specified).
 4. The outputs are measured one at a time with one transition per measurement.
 5. $V_{REF} = V_{DD}/2$
 6. $V_{IH} = V_{REF} + 250\text{ mV}$ (ac voltage levels) for differential inputs. $V_{IH} = V_{DD}$ for LVCMOS input.
 7. $V_{IL} = V_{REF} - 250\text{ mV}$ (ac voltage levels) for differential inputs. $V_{IL} = \text{GND}$ for LVCMOS input.
 8. $V_{ID} = 600\text{ mV}$
 9. t_{PLH} and t_{PHL} are the same as t_{PDM} .



LOAD CIRCUIT – HIGH-TO-LOW SLEW-RATE MEASUREMENT



VOLTAGE WAVEFORMS – HIGH-TO-LOW SLEW-RATE MEASUREMENT

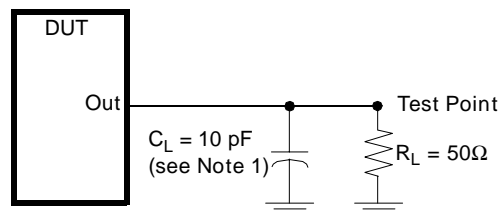

LOAD CIRCUIT – LOW-TO-HIGH SLEW-RATE MEASUREMENT

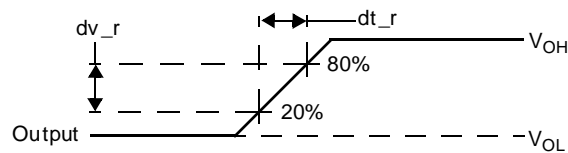

VOLTAGE WAVEFORMS – LOW-TO-HIGH SLEW-RATE MEASUREMENT

Figure 7 — Output Slew-Rate Measurement Information ($V_{DD} = 1.8 \text{ V} \pm 0.1 \text{ V}$)

Notes: 1. C_L includes probe and jig capacitance.

2. All input pulses are supplied by generators having the following characteristics: $PRR \leq 10\text{MHz}$, $Z_O = 50\Omega$, input slew rate = $1 \text{ V/ns} \pm 20\%$ (unless otherwise specified).

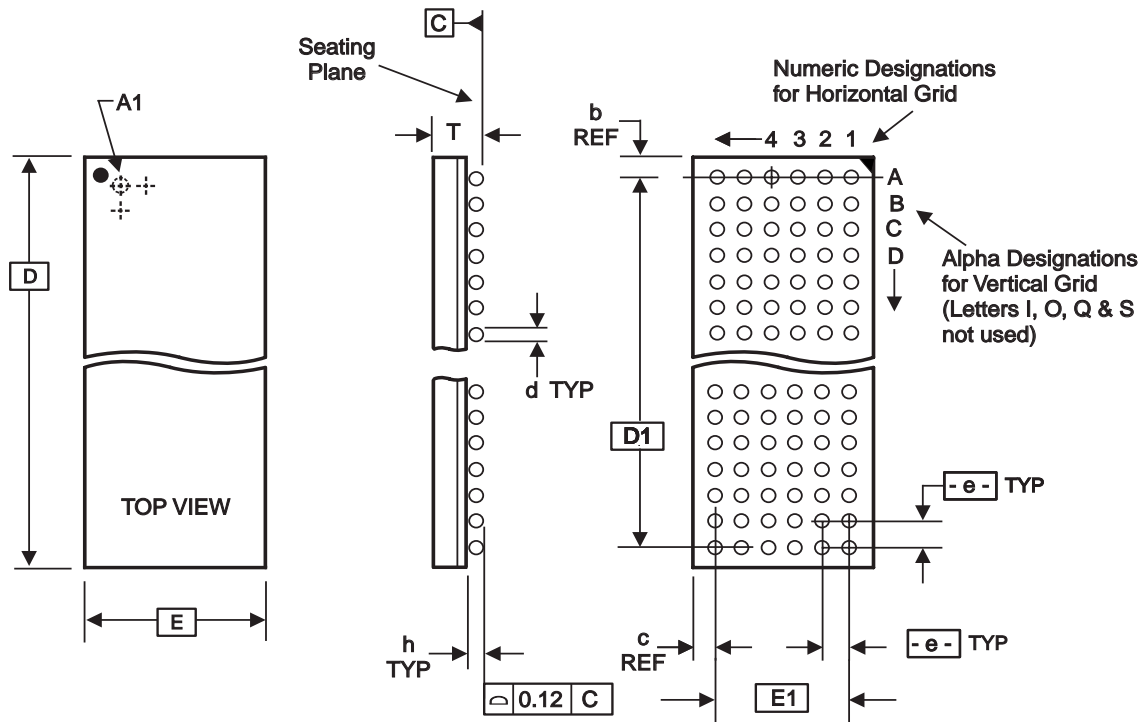

ALL DIMENSIONS IN MILLIMETERS

D	E	T	e	----- BALL GRID -----		Max. TOTAL	d	h	REF. DIMENSIONS	
				HORIZ	VERT				b	c
		Min/Max					Min/Max	Min/Max		
16.00 Bsc	5.50 Bsc	1.30/1.50	0.80 Bsc	6	19	114	0.40/0.50	0.31/0.41	0.80	0.75
13.50 Bsc	5.50 Bsc	1.30/1.50	0.80 Bsc	6	16	96	0.40/0.50	0.25/0.41	0.75	0.75
7.00 Bsc	4.50 Bsc	0.86/1.00	0.65 Bsc	6	10	60	0.35/0.45	0.15/0.21	0.575	0.625

Note: Ball grid total indicates maximum ball count for package. Lesser quantity may be used.

* Source Ref.: JEDEC Publication 95, MO-205

10-0055C

Ordering Information

ICSSSTU32864yHT

Example:

ICS XXXX y H - T

