

1/3 inch CCD Image Sensor for PAL Color Camera

Description

The ICX045BKA is an interline transfer CCD solid-state image sensor suitable for PAL 1/3 inch color video cameras. High sensitivity is achieved through the adoption of Ye, Cy, Mg and G complementary color mosaic filters and HAD (Hole-Accumulation Diode) sensors.

This chip features a field integration read out system and an electronic shutter with variable charge-storage time. 20 pin Cer-DIP package.

Features

- High sensitivity (+6dB compare with ICX045AK) and low dark current
- Consecutive various speed shutter
- Low smear
- High antiblooming
- Ye, Cy, Mg, G on chip type complementary color mosaic filter.
- Horizontal register 5V drive
- Reset gate 5V drive

Device Structure

- Optical size 1/3 inch format
- Number of effective pixels
500 (H) × 582 (V) Approx. 290k pixels
- Number of total pixels
537 (H) × 597 (V) Approx. 320k pixels
- Interline transfer CCD image sensor
- Chip size 6.3mm (H) × 5.4mm (V)
- Unit cell size 9.8 μm (H) × 6.3 μm (V)
- Optical black
Horizontal (H) direction Front 7 pixels Rear 30 pixels
Vertical (V) direction Front 14 pixels Rear 1 pixels
- Number of dummy bits
Horizontal 16
Vertical 1 (even field only)
- Substrate material silicon

Package Outline

Unit : mm

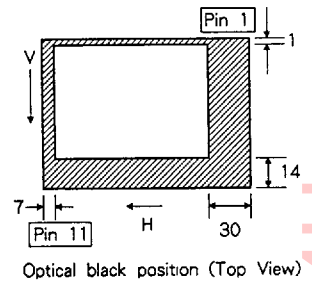
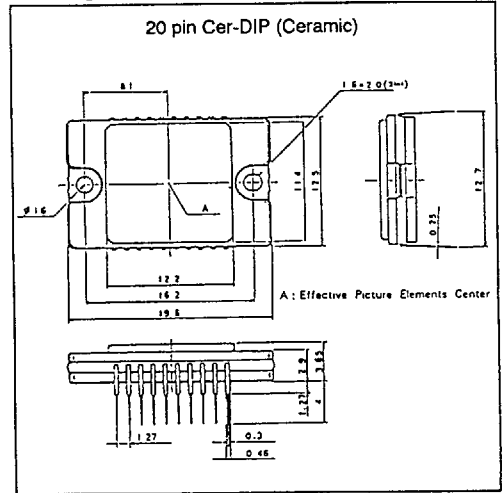

Block Diagram

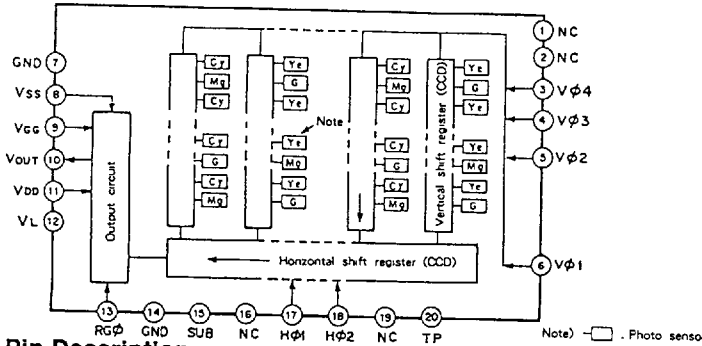

Pin Configuration (Top View)

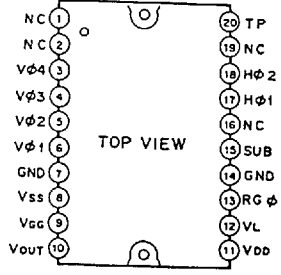

Pin Description

No.	Symbol	Description	No.	Symbol	Description
1	NC		11	VDD	Output amplifier drain supply
2	NC		12	VL	Protective transistor bias
3	V φ 4	Vertical register transfer clock	13	RG φ	Reset gate clock
4	V φ 3	Vertical register transfer clock	14	GND	GND
5	V φ 2	Vertical register transfer clock	15	SUB	Substrate (Overflow drain)
6	V φ 1	Vertical register transfer clock	16	NC	
7	GND	GND	17	H φ 1	Horizontal register transfer clock
8	VSS	Output amplifier source	18	H φ 2	Horizontal register transfer clock
9	VGG	Output amplifier gate bias	19	NC	
10	Vout	Signal output	20	TP	Input bias

Absolute Maximum Ratings

Item		Ratings	Unit	Remarks
Substrate voltage SUB-GND		-0.3 to +55	V	
Supply voltage	VDD, Vout, VSS, TP - GND	-0.3 to +18	V	
	VDD, Vout, VSS, TP - SUB	-55 to +10	V	
Clock input voltage	V φ 1, V φ 2, V φ 3, V φ 4, H φ 1, H φ 2 - GND	-15 to +20	V	
	V φ 1, V φ 2, V φ 3, V φ 4, H φ 1, H φ 2 - SUB	to +10	V	
Voltage difference between vertical clock input pins		to+15	V	*
Voltage difference between horizontal clock input pins		to+17	V	
H φ 1, H φ 2 - V φ 4		-17 to +17	V	
RG, VGG - GND		-10 to +15	V	
RG, VGG - SUB		-55 to +10	V	
VL - SUB		-65 to +0.3	V	
Beside GND, SUB-VL		-0.3 to +30	V	
Storage temperature		-30 to +80	°C	
Operating temperature		-10 to +60	°C	

* +27V (Max.) when clock width < 10 μs, duty factor < 0.1%.

Bias Conditions

Item	Symbol	Min.	Typ.	Max.	Unit	Remarks
Output amplifier drain voltage	V _{DD}	14.55	15.0	15.45	V	
Output amplifier gate voltage	V _{GG}	1.75	2.0	2.25	V	
Output amplifier source	V _{SS}	Ground through 680 Ω resistor				± 5%
Substrate voltage adjustment range	V _{SUB}	9.0		18.5	V	* 1
Fluctuation range after substrate voltage adjustment	Δ V _{SUB}	-3		+3	%	
Reset gate clock voltage adjustment range	V _{RGL}	0.5		4.0	V	* 1
Fluctuation range after reset gate clock voltage adjustment	Δ V _{RGL}	-3		+3	%	
Protective transistor bias	V _L	* 2				
Input bias	TP	14.55	15.0	15.45	V	

DC Characteristics

Item	Symbol	Min.	Typ.	Max.	Unit	Remarks
Output amplifier drain current	I _{DD}		3		mA	
Input current	I _{IN1}			1	μA	* 3
Input current	I _{IN2}			10	μA	* 4

- * 1) Substrate voltage (V_{SUB}) • reset gate clock voltage (V_{RGL}) setting value display.
 Setting values of substrate voltage and reset gate clock voltage are displayed at the back of the device through a code address. Adjust substrate voltage (V_{SUB}) and reset gate clock voltage (V_{RGL}) to the displayed voltage. Fluctuation range after adjustment is ± 3%.

V_{SUB} code address—1 digit display
 V_{RGL} code address—1 digit display

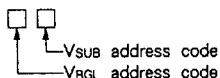

Code addresses and actual numerical values correspond to each other as follows.

V _{RGL} address code	0	1	2	3	4	5	6	7
Numerical value	0.5	1.0	1.5	2.0	2.5	3.0	3.5	4.0

V _{SUB} address code	E	f	G	h	J	K	L	m	N	P	Q	R	S	T	U	V	W	X	Y	Z
Numerical value	9.0	9.5	10.0	10.5	11.0	11.5	12.0	12.5	13.0	13.5	14.0	14.5	15.0	15.5	16.0	16.5	17.0	17.5	18.0	18.5

<Example> "5L" → V_{RGL}=3.0V
 V_{SUB}=12.0V

- * 2) V_L setting is the V_L voltage of the vertical transfer clock waveform.

- * 3) 1. Current to each pin when 18V is applied to V_{DD}, V_{OUT}, V_{SS}, SUB, TP pins, while pins that are not tested are grounded.
- 2. Current to each pins when 20V is applied sequentially to V ϕ 1, V ϕ 2, V ϕ 3, V ϕ 4, H ϕ 1 and H ϕ 2, while pins that are not tested are grounded. However, 20V is applied to SUB.
- 3. Current to each pins when 15V is applied sequentially to pins RG and V_{GG}, while pins that are not tested are grounded. However, 15V is applied to SUB.
- 4. Current to V_L pin when it is grounded, while 30V is applied to all pins except pins that are not tested. However, GND and SUB pins are kept open.
- * 4) Current to SUB pin when 55V is applied to SUB pin, while pins that are not tested are grounded.

Clock Voltage Conditions

Item	Symbol	Min.	Typ.	Max.	Unit	Waveform diagram	Remarks
Read out clock voltage	V _{VT}	14.55	15.0	15.45	V	1	
Vertical transfer clock voltage	V _{VH1} , V _{VH2} V _{VH3} , V _{VH4}	- 0.2	0	0.1	V	2	V _{VH} = (V _{VH1} +V _{VH2}) /2
	V _{VL1} , V _{VL2} , V _{VL3} , V _{VL4}	- 9.6	- 9.0	- 8.5	V	2	V _{VL} = (V _{VL3} +V _{VL4}) /2
	V ϕ v	8.3	9.0	9.7	V	2	V ϕ v = V _{VHn} - V _{VLn} (n=1 to 4)
	V _{VH1} - V _{VH2}			0.1	V	2	
	V _{VH3} - V _{VH}	- 0.25		0.1	V	2	
	V _{VH4} - V _{VH}	- 0.25		0.1	V	2	
	V _{VHH}			0.5	V	2	High level coupling
	V _{VHL}			0.5	V	2	High level coupling
	V _{VLH}			0.5	V	2	Low level coupling
	V _{VLL}			0.5	V	2	Low level coupling
Horizontal transfer clock voltage	V ϕ H	4.75	5.0	5.25	V	3	
	V _H L	- 0.05	0	0.05	V	3	
Reset gate clock voltage	V ϕ RG	4.5	5.0	5.5	V	4	*
	V _{RGLH} - V _{RGLL}			0.8	V	4	Low level coupling
Substrate clock voltage	V ϕ SUB	23.0	24.0	25.0	V	5	

* No adjustment of reset gate clock voltage is necessary when reset gate clock is driven as indicated below. In this case, reset gate clock voltage set point displayed on back of image sensor has no meaning.

Item	Symbol	Min.	Typ.	Max.	Unit	Waveform diagram	Remarks
Reset gate clock voltage	V _{RGL}	- 0.1	0	0.1	V	4	
	V ϕ RG	8.5	9.0	9.5	V	4	

Clock Equivalent Circuit Constant

Item	Symbol	Min.	Typ.	Max.	Unit	Remarks
Capacitance between vertical transfer clock and GND	C φ v1, C φ v3		820		pF	
	C φ v2, C φ v4		1000		pF	
Capacitance between vertical transfer clocks	C φ v12, C φ v34		680		pF	
	C φ v23, C φ v41		470		pF	
Capacitance between horizontal transfer clock and GND	C φ h1, C φ h2		40		pF	
Capacitance between horizontal transfer clocks	C φ HH		40		pF	
Capacitance between reset gate clock and GND	C φ RG		5		pF	
Capacitance between substrate clock and GND	C φ SUB		270		pF	
Vertical transfer clock serial resistor	R1, R2, R3, R4		80		Ω	
Vertical transfer clock ground resistor	R _{GND}		15		Ω	
Horizontal transfer clock serial resistor	R φ H		20		Ω	

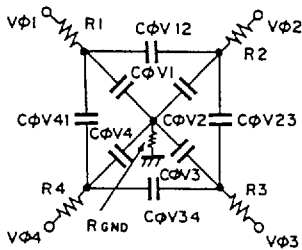

Vertical transfer clock equivalent circuit

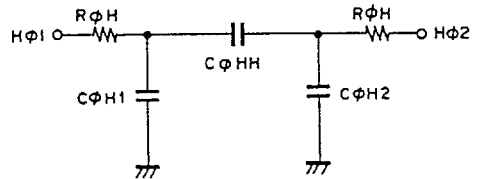

Horizontal transfer clock equivalent circuit

Drive Clock Waveform Conditions

(1) Read out clock waveform

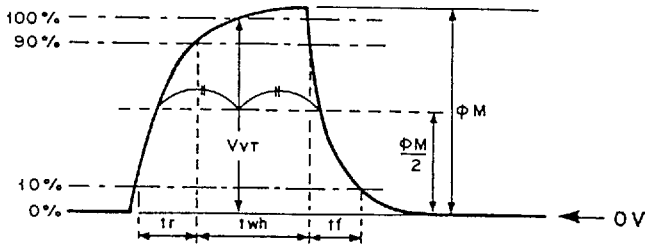

(2) Vertical transfer clock waveform

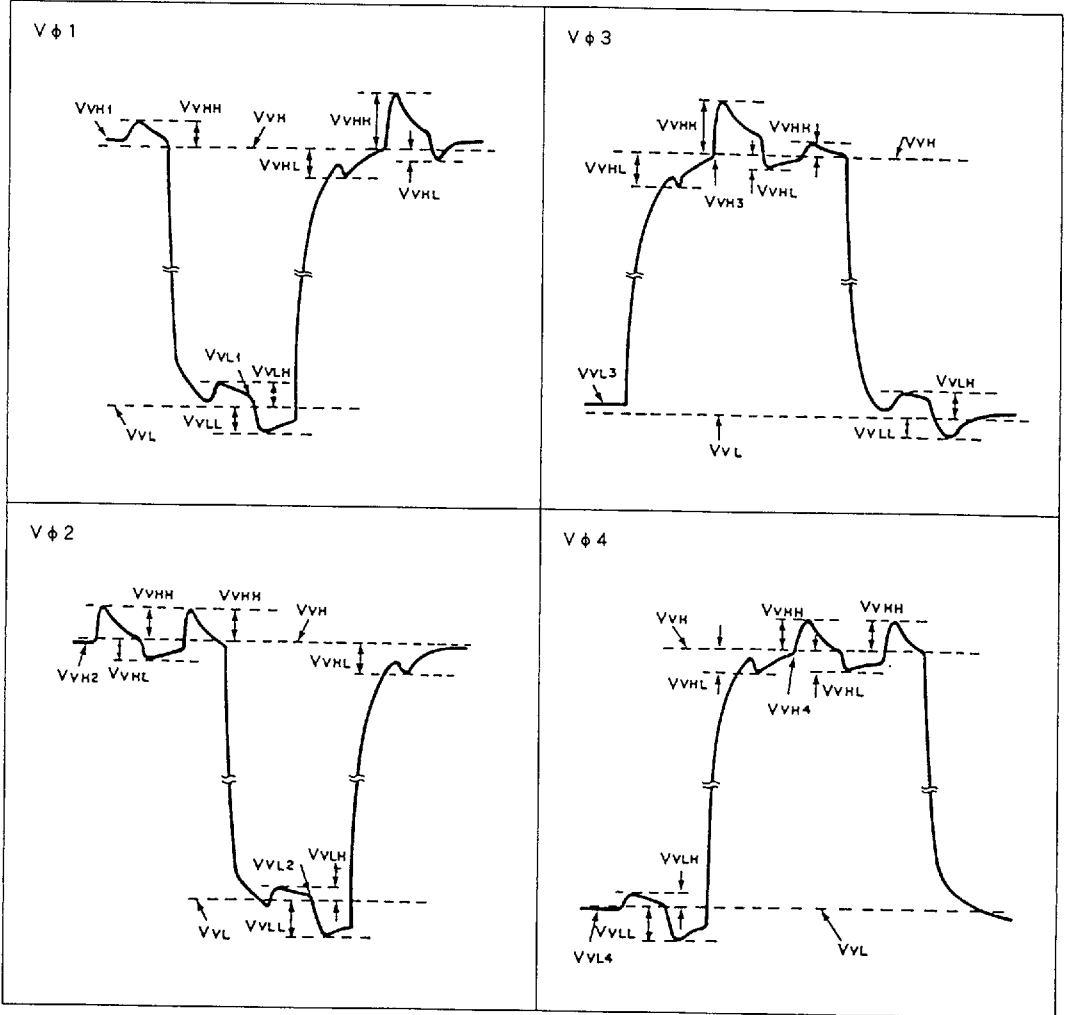

(3) Horizontal transfer clock waveform diagram

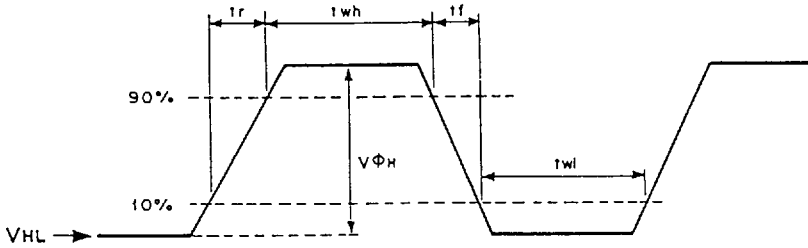

(4) Reset gate clock waveform diagram

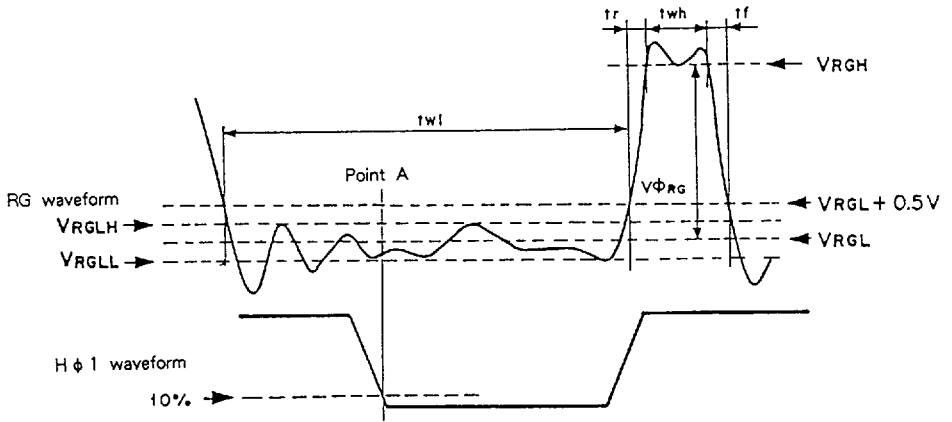

V_{RGLH} is the maximum value and V_{RGLL} the minimum value of the coupling waveform in the period from Point A in the diagram above to RG rise.

V_{RGL} is the mean value for V_{RGLH} and V_{RGLL} .

$$V_{RGL} = (V_{RGLH} + V_{RGLL}) / 2$$

V_{RGH} is the minimum value for t_{wh} period.

$$V_{\phi RG} = V_{RGH} - V_{RGL}$$

(5) Substrate clock waveform

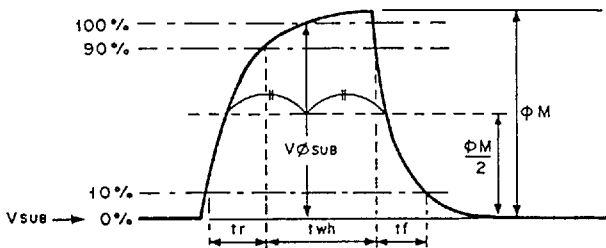

Clock Switching Characteristics

Item	Symbol	twh			twl			tr			tf			Unit	Remarks
		Min.	Typ.	Max.	Min.	Typ.	Max.	Min.	Typ.	Max.	Min.	Typ.	Max.		
Read out clock	V_T	2.3	2.5						0.5			0.5		μs	During read out
Vertical transfer clock	$V \phi 1, V \phi 2, V \phi 3, V \phi 4$										0.015		0.25	μs	*1
Horizontal transfer clock	$H \phi$	37	41		38	42			12	15	*2	12	15	ns	During imaging
Horizontal transfer clock	$H \phi 1$		5.6					0.012				0.012		μs	During parallel serial conversion.
Horizontal transfer clock	$H \phi 2$					5.6		0.012				0.012		μs	
Reset gate clock	ϕ_{RG}	11	15		75	79			6.5			4.5		ns	
Substrate clock	ϕ_{SUB}	1.5	2.0						0.5			0.5		μs	During charge drain.

* 1) When vertical transfer clock driver CXD1250 is in use.

* 2) $t_f \geq t_r - 2 \text{ ns}$

Image Sensor Characteristics

(Ta=25°C)

Item	Symbol	Min.	Typ.	Max.	Unit	Test method	Remarks
Sensitivity	S	340	450		mV	1	
Saturation signal	Ysat	540			mV	2	Ta=60°C
Smear	Sm		0.007	0.012	%	3	
					20	%	4
Video signal shading	SHy			25	%	4	Zone 0 to II'
Uniformity between signal channels	Δ Sr			10	%	5	
	Δ Sb			10	%	5	
Dark signal	Ydt			2	mV	6	Ta=60°C
Dark signal shading	Δ Ydt			1	mV	7	Ta=60°C
Flicker Y	Fy			2	%	8	
Flicker R - Y	Fcr			5	%	8	
Flicker B - Y	Fcb			5	%	8	
Horizontal stripes R	Lcr			3.5	%	9	
Horizontal stripes G	Lcg			3.5	%	9	
Horizontal stripes B	Lcb			3.5	%	9	
Horizontal stripes W	Lcw			3.5	%	9	
Lag	Lag			0.5	%	10	

Zone Chart of Video Signal Shading

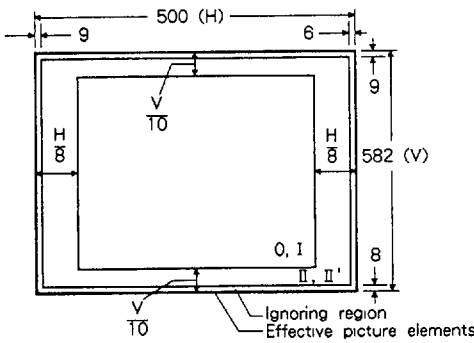

Testing System

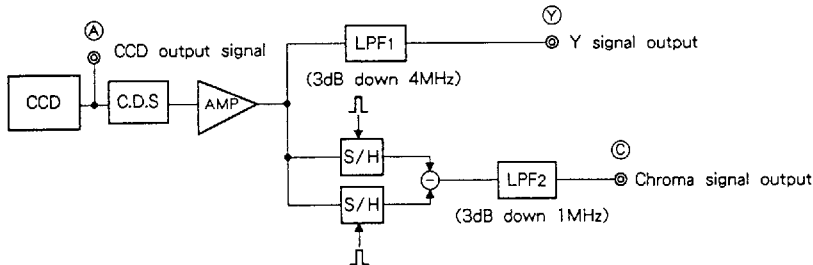

Note) Adjust AMP gain so that total gains between (A) and (Y) and between (A) and (C) equal 1.

Image Sensor Characteristics Test Method

◎ **Test conditions**

- ① Through the following tests the substrate voltage and reset gate clock voltage are set to the value displayed on the device, while the device drive conditions are at the typical value of the bias and clock voltage conditions.
- ② Through the following tests defects are excluded and, unless otherwise specified, the optical black level (Hence forth referred to as OB) is set as the reference for the signal output which is taken as the Y signal output or the chroma signal output of the testing system.

◎ **Color coding of CFA (Color Filter Array) & Composition of luminance (Y) and chrominance (C) signals**

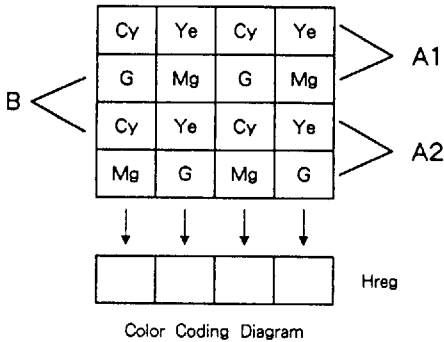

CFA of this image sensor is shown in the Figure. This complementary CFA is used with a "field integration mode", where all of the photosites are read out during each video field. Signals from two vertically adjacent photosites, such as line A1 or A2 for field A, are summed when the image charge is transferred into the vertical storage columns.

The read out line pairing is shifted down one line for field B. The sensor output signals through the horizontal register (H reg.) at line A1 are [G+Cy], [Mg+Ye], [G+Cy], [Mg+Ye].

These signals are processed in order to compose Y and C signals. By adding the two adjacent signals at line A1, Y signal is formed as follows:

$$Y = \{ (G+Cy) + (Mg+Ye) \} \times 1/2$$

$$= 1/2 \{ 2B+3G+2R \}$$

C signal is composed by subtracting the two adjacent signals at line A1.

$$R - Y = \{ (Mg+Ye) - (G+Cy) \}$$

$$= \{ 2R - G \}$$

Next, the signals through H reg. at line A2 are

$$[Mg+Cy], [G+Ye], [Mg+Cy], [G+Ye]$$

Similarly, Y and C signals are composed at line A2.

$$Y = \{ (G+Ye) + (Mg+Cy) \} \times 1/2$$

$$= 1/2 \{ 2B+3G+2R \}$$

$$- (B - Y) = \{ (G+Ye) - (Mg+Cy) \}$$

$$= - \{ 2B - G \}$$

Accordingly, Y signal is balanced in relation to the scanning lines, and C signal takes the form of R - Y and - (B - Y) on alternate lines.

It is the same for B field.

◎ Definition of standard imaging conditions

- ① Standard imaging condition I: (As imaging device) Use a pattern box (luminance 706 Nit, color temperature 3200k Halogen source) as a subject. (Pattern for evaluation is not applicable.) Use a testing standard lens with CM500S (1.0mmt) as IR cut filter and image at F5.6.
- ② Standard imaging condition II: Image a light source (color temperature of 3200k) which uniformity of brightness is within 2% at all angles. Use a testing standard lens with CM500S (1.0mmt) as IR cut filter. The light intensity is adjusted to the value indicated in each testing item by lens diaphragm.

1. Sensitivity

Set to standard image condition I. After selecting the electronic shutter mode at a 1/250 sec. shutter speed, measure the Y signal (Y_s) at the center of the screen and substitute in the following formula.

$$S = Y_s \times \frac{250}{60}$$

2. Saturation signal

Set to standard imaging condition II. Adjust light intensity to 10 times that of Y signal output average value ($Y_A=180\text{mV}$), then test Y signal minimum value.

3. Smear

Set to standard imaging condition II. Adjust light intensity to 500 times that of Y signal output average value ($Y_A=180\text{mV}$). Stop read out clock. When the charge drain executed by the electronic shutter at the respective H blankings takes place, test the maximum value Y_{Sm} of Y signal output.

$$S_m = \frac{Y_{Sm}}{Y_A} \times \frac{1}{500} \times \frac{1}{10} \times 100 (\%) (1/10V)$$

4. Video signal shading

Set to standard imaging condition II. Adjust light intensity to Y signal output average value ($Y_A=180\text{mV}$) with lens diaphragm at F5.6 to F8. Then test maximum (Y_{max}) and minimum (Y_{min}) values of Y signal.

$$SH_y = (Y_{max} - Y_{min}) / Y_A \times 100 (\%)$$

5. Video signal between channels uniformity

Set to standard imaging condition II. Adjust light intensity to Y signal output average value ($Y_A=180\text{mV}$). Then test maximum (C_{rmax} , C_{bmax}) and minimum (C_{rmin} , C_{bmin}) values of chroma signals from R - Y and B - Y channels.

$$\Delta S_r = |(C_{rmax} - C_{rmin}) / Y_A| \times 100 (\%)$$

$$\Delta S_b = |(C_{bmax} - C_{bmin}) / Y_A| \times 100 (\%)$$

6. Dark signal

Test Y signal output average value Y_{dt} when the device ambient temperature is at 60 °C and light is obstructed with horizontal idle transfer level as reference.

7. Dark signal shading

Following 6, test maximum (Y_{dmax}) and minimum (Y_{dmin}) values of dark signal output.

$$\Delta Y_{dt} = Y_{dmax} - Y_{dmin}$$

8. Flicker

① Fy

Set to standard imaging condition II. Adjust light intensity to Y signal output average value ($Y_A=180\text{mV}$). Then test the Y signal difference (ΔY_f) between even field and odd field.

$$F_y = (\Delta Y_f / Y_A) \times 100 (\%)$$

② Fcr, Fcb

Set to standard imaging condition II. Adjust light intensity to Y signal output average value ($Y_A=180\text{mV}$). Then insert R or B filter, and test the C signal difference (ΔC_r , ΔC_b) between even field and odd field and the C signal output average value (C_{Ar} , C_{Ab}).

$$F_{ci} = (\Delta C_i / C_{Ai}) \times 100 (\%) \quad (i=r, b)$$

9. Lateral stripe

Set to standard imaging condition II. Adjust light intensity to Y signal output average value ($Y_A=180\text{mV}$). Then insert R, G and B filters respectively, and test the signal difference (ΔY_w , ΔY_r , ΔY_g , ΔY_b) between Y signal lines of the same field.

$$L_{ci} = (\Delta Y_{li} / Y_A) \times 100 (\%) \quad (i=w, r, g, b)$$

10. Residual image

Adjust Y signal output value (Y_s) by strobe light to 200mV . Then light a stroboscopic tube with the following timing and test the residual image (Y_{lag}).

$$Lag = (Y_{lag} / Y_s) \times 100 (\%)$$

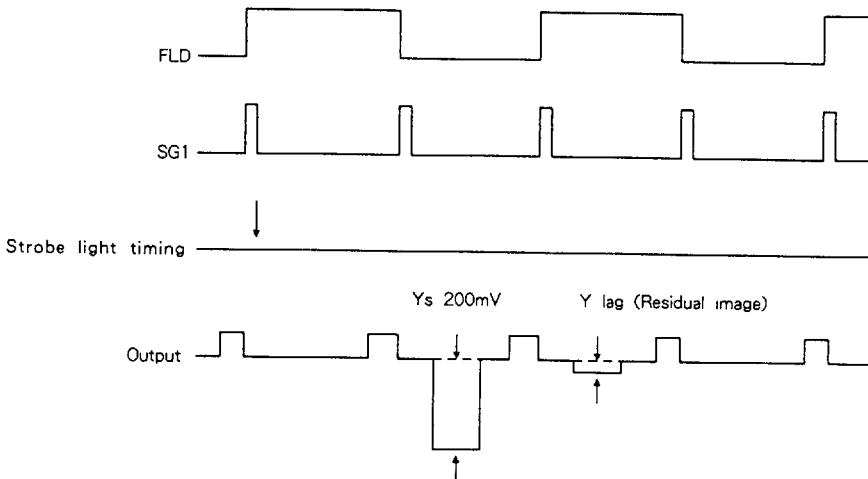

Drive Circuit

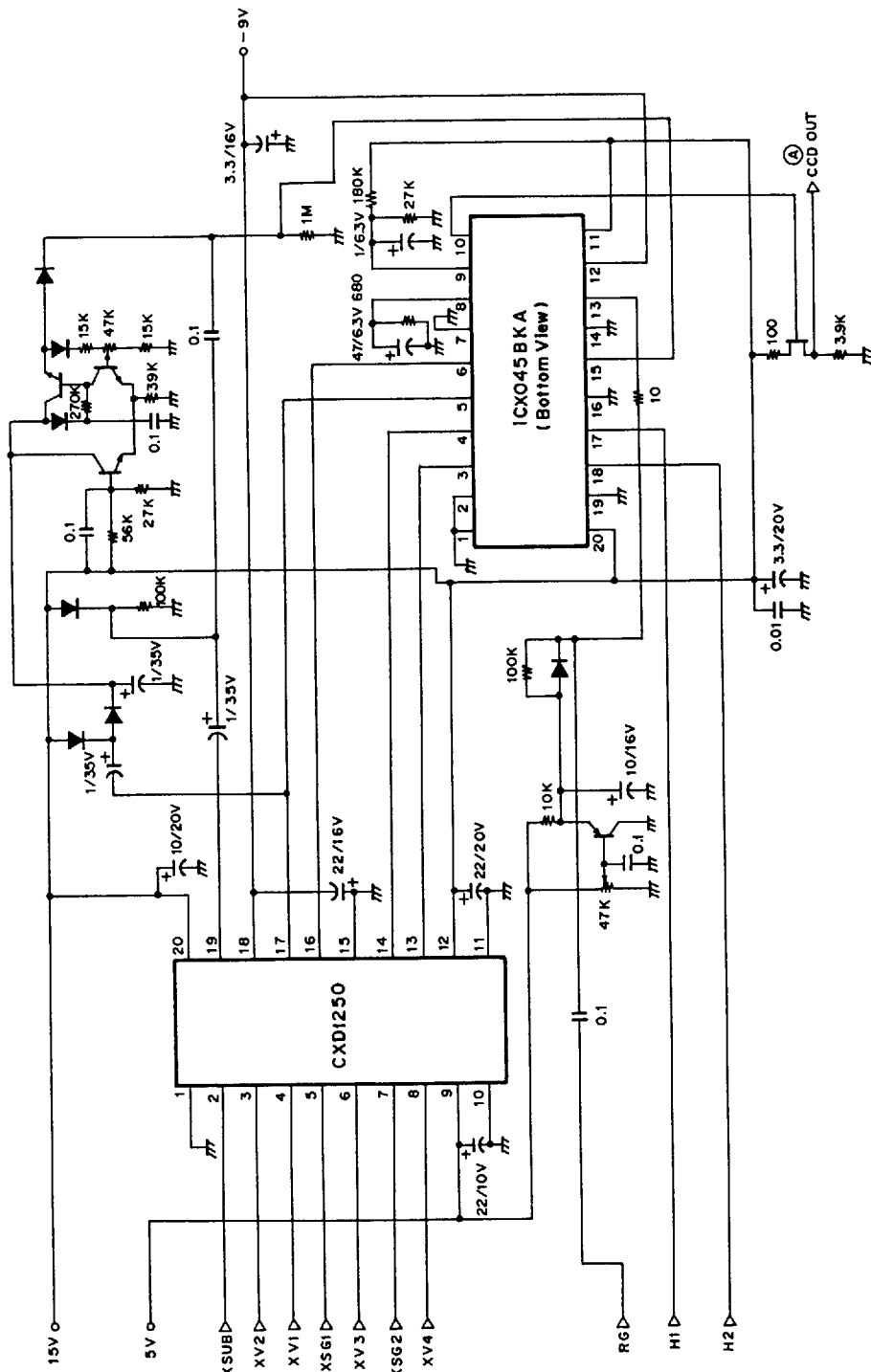

Spectral Sensitivity Characteristics

(Excluding light source characteristics, including lens characteristics)

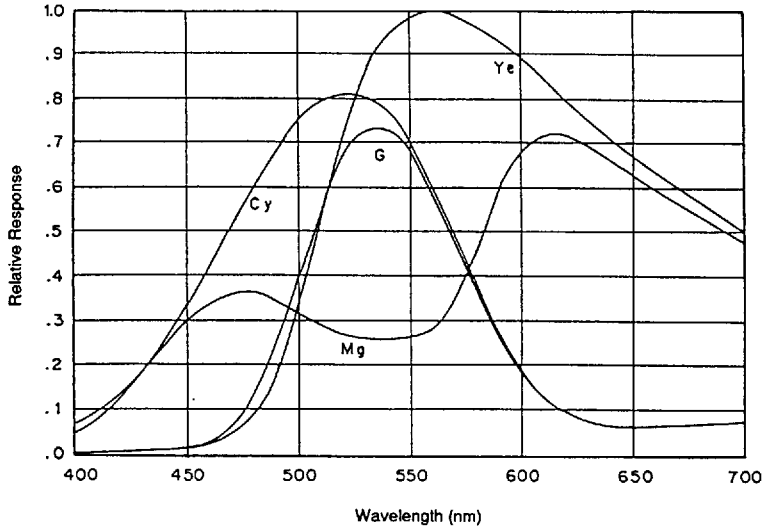

Sensor Read Out Clock Timing Chart

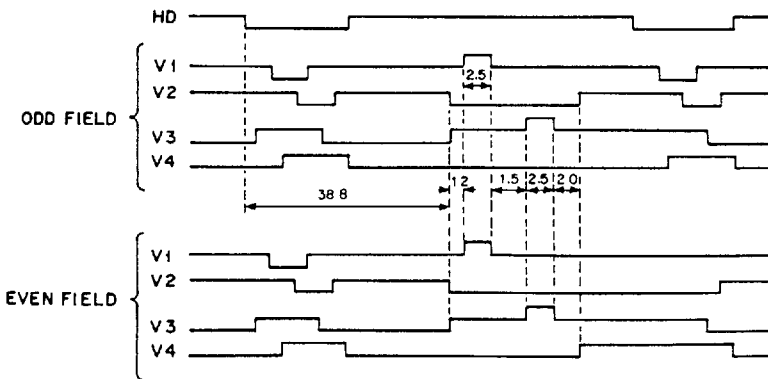

Drive Timing Chart (Vertical sync)

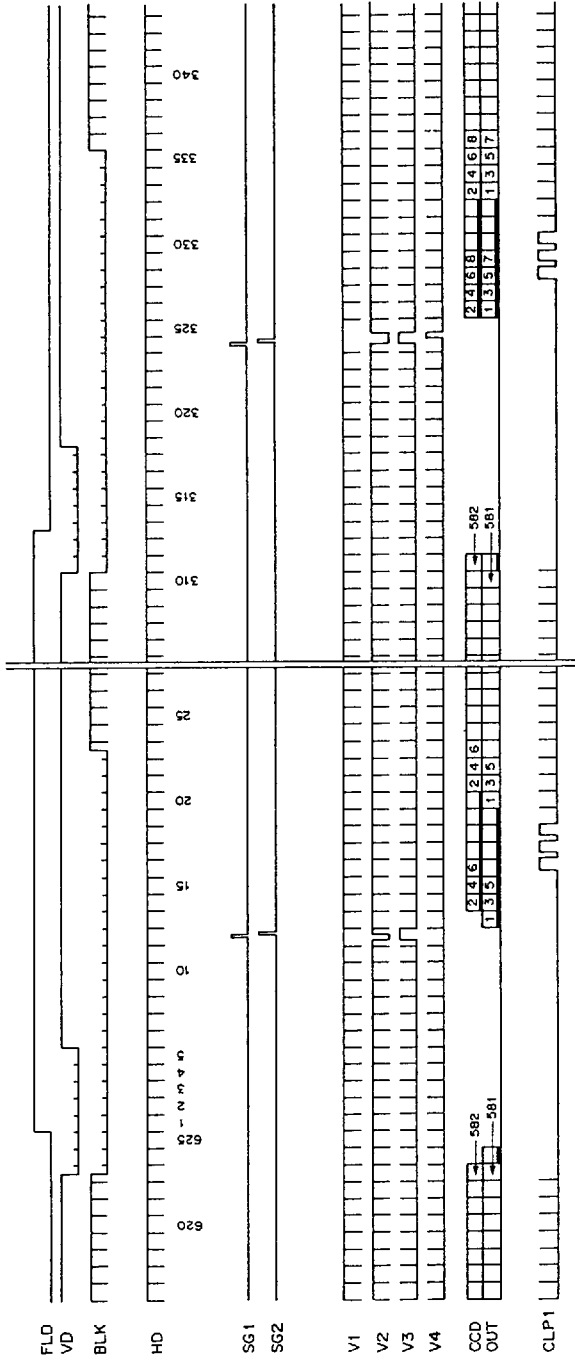

Drive Timing Chart (Horizontal sync)

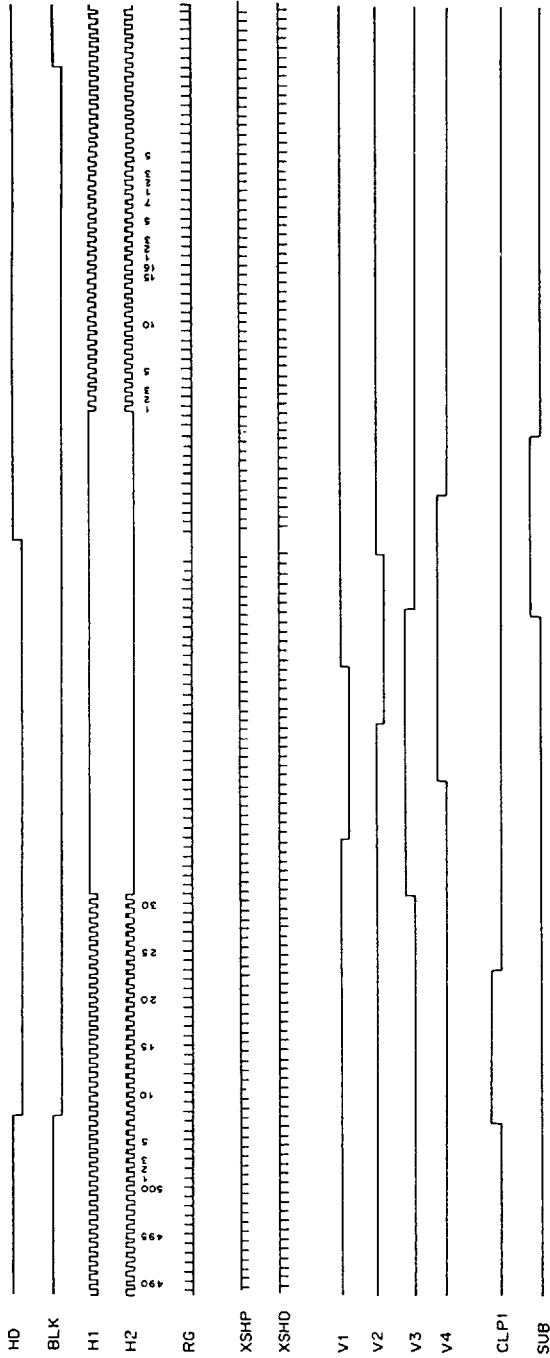

(During electronic shutter operation)

Handling Instructions

- 1) **Static charge prevention**
CCD image sensors are easily damaged by static discharge. Before handling be sure to take the following protective measures.
 - a) Either handle bare handed or use non chargeable gloves, clothes or material. Also use conductive shoes.
 - b) When handling directly use an earth band.
 - c) Install a conductive mat on the floor or working table to prevent the generation of static electricity.
 - d) Ionized air is recommended for discharge when handling CCD image sensor.
 - e) For the shipment of mounted substrates use boxes treated for the prevention of static charges.

- 2) **Soldering**
 - a) Make sure the package temperature does not exceed 80 °C .
 - b) Solder dipping in a mounting furnace causes damage to the glass and other defects. Use a grounded 30W soldering iron and solder each pin in less than 2 seconds. For repairs and remount, cool sufficiently.
 - c) To dismount an imaging device do not use a solder suction equipment. When using an electric desoldering tool use a thermal controller of the zero cross On/Off type and connect to ground.

- 3) **Dust and dirt protection**
 - a) Operate in clean environments (around class 1000 will be appropriate).
 - b) Do not either touch glass plates by hand or have any object come in contact with glass surfaces. Should dirt stick to a glass surface blow it off with an air blow. (For dirt stuck through static electricity ionized air is recommended)
 - c) Clean with a cotton bud and ethyl alcohol if the glass surface is grease stained. Be careful not to scratch the glass.
 - d) Keep in case to protect from dust and dirt. To prevent dew condensation, preheat or precool when moving to a room with great temperature differences.
 - e) When a protective tape is applied before shipping, just before use remove the tape applied for electrostatic protection. Do not reuse the tape.

- 4) Do not expose to strong light (sun rays) for long periods, color filters are discolored.

- 5) Exposure to high temperatures or humidity will affect the characteristics. Accordingly avoid storage or usage in such conditions.

- 6) CCD image sensor are precise optical equipment that should not be subject to mechanical shocks.