

Diagonal 6mm (Type 1/3) CCD Image Sensor for NTSC Color Camera

www.DataSheet4U.com

Description

The ICX058AKB is an interline transfer CCD solid-state image sensor suitable for NTSC color video cameras. High sensitiveness and low dark current are achieved through the adoption of Ye, Cy, Mg and G complementary color mosaic filters and HAD (Hole-Accumulation Diode) sensors.

This chip features a field integration read out system and an electronic shutter with variable charge-storage time. Also, this outline is miniaturized by using original package.

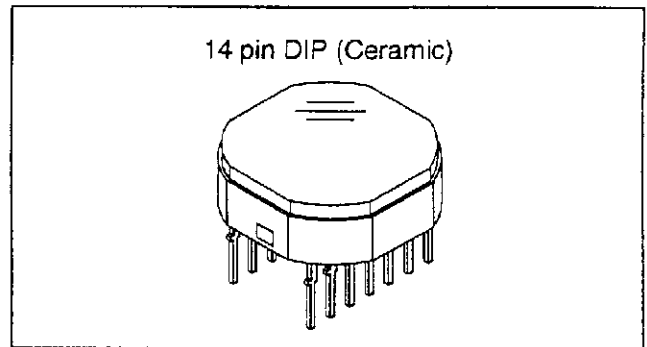

Features

- High image, high sensitivity and low dark current
- Consecutive various speed shutter
1/60s (Typ.), 1/100s to 1/10000s
- Low smear
- High antiblooming
- Ye, Cy, Mg, G on chip type complementary color mosaic filter.
- Horizontal register 5V drive
- Reset gate 5V drive

Device Structure

- Image size Diagonal 6mm (Type 1/3)
- Number of effective pixels 768 (H) × 494 (V) Approx. 380k pixels
- Number of total pixels 811 (H) × 508 (V) Approx. 410k pixels
- Interline transfer CCD image sensor
- Chip size 6.00mm (H) × 4.96mm (V)
- Unit cell size 6.35 μm (H) × 7.4 μm (V)
- Optical black Horizontal (H) direction Front 3 pixels Rear 40 pixels
Vertical (V) direction Front 12 pixels Rear 2 pixels
- Number of dummy bits Horizontal 22
Vertical 1 (even field only)
- Board material N-type silicon

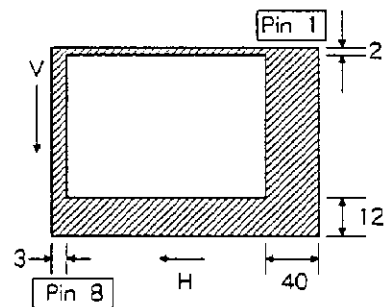

Optical black position (Top View)

Sony reserves the right to change products and specifications without prior notice. This information does not convey any license by any implication or otherwise under any patents or other right. Application circuits shown, if any, are typical examples illustrating the operation of the devices. Sony cannot assume responsibility for any problems arising out of the use of these circuits.

Block Diagram

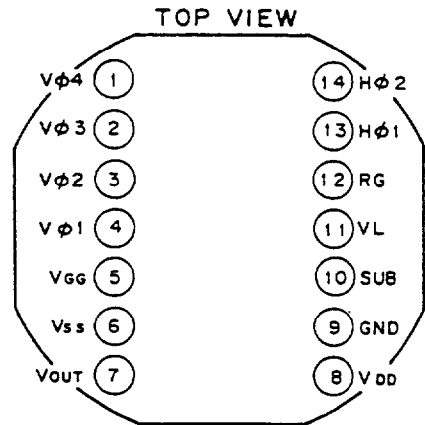
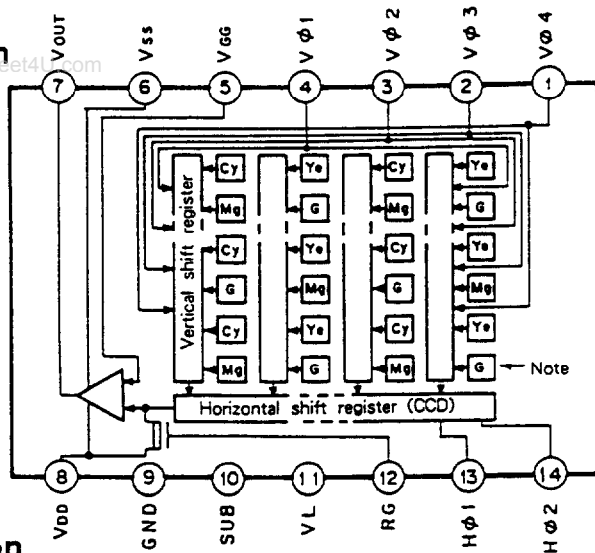

Pin Description

No.	Symbol	Description	No.	Symbol	Description
1	Vφ4	Vertical register transfer clock	8	VDD	Output amplifier drain supply
2	Vφ3	Vertical register transfer clock	9	GND	GND
3	Vφ2	Vertical register transfer clock	10	SUB	Substrate (Overflow drain)
4	Vφ1	Vertical register transfer clock	11	VL	Protective transistor bias
5	VGG	Output amplifier gate bias	12	RG	Reset gate clock
6	VSS	Output amplifier source	13	Hφ1	Horizontal register transfer clock
7	VOUT	Signal output	14	Hφ2	Horizontal register transfer clock

Note) : Photo sensor

Absolute Maximum Ratings

Item	Ratings	Unit	Remarks
Substrate voltage SUB-GND	-0.3 to +55	V	
Supply voltage	VDD, VOUT, VSS - GND	-0.3 to +18	V
	VDD, VOUT, VSS - SUB	-55 to +10	V
Vertical clock input voltage	Vφ1, Vφ2, Vφ3, Vφ4 - GND	-15 to +20	V
	Vφ1, Vφ2, Vφ3, Vφ4 - SUB	to +10	V
Voltage difference between vertical clock input pins	to +15	V	*
Voltage difference between horizontal clock input pins	to +17	V	
Hφ1, Hφ2-Vφ4	-17 to +17	V	
Hφ1, Hφ2, RG, VGG - GND	-10 to +15	V	
Hφ1, Hφ2, RG, VGG - SUB	-55 to +10	V	
VL - SUB	-65 to +0.3	V	
Vφ1, Vφ2, Vφ3, Vφ4, VDD, VOUT-VL	-0.3 to +30	V	
RG-VL	-0.3 to +24	V	
VGG, VSS, Hφ1, Hφ2-VL	-0.3 to +20	V	
Storage temperature	-30 to +80	°C	
Operating temperature	-10 to +60	°C	

* +27V (Max.) when clock width < 10 μs, duty factor < 0.1%.

Bias Conditions

Item	Symbol	Min.	Typ.	Max.	Unit	Remarks
Output amplifier drain voltage	V _{DD}	14.55	15.0	15.45	V	
Output amplifier gate voltage	V _{GG}	3.8	4.2	4.65	V	
Output amplifier source	V _{SS}	Ground through 820 Ω resistor				±5%
Substrate voltage adjustment range	V _{SUB}	9.0		18.5	V	*2
Fluctuation range after substrate voltage adjustment	ΔV _{SUB}	-3		+3	%	
Reset gate clock voltage adjustment range	V _{RGL}	1.0		4.0	V	*2 *6
Fluctuation range after reset gate clock voltage adjustment	ΔV _{RGL}	-3		+3	%	
Protective transistor bias	V _L	*3				

DC Characteristics

Item	Symbol	Min.	Typ.	Max.	Unit	Remarks
Output amplifier drain current	I _{DD}		5		mA	
Input current	I _{IN1}			1	μA	*4
Input current	I _{IN2}			10	μA	*5

*2 Substrate voltage (V_{SUB}) • reset gate clock voltage (V_{RGL}) setting value display.
 Setting values of substrate voltage and reset gate clock voltage are displayed at the back of the device through a code address. Adjust substrate voltage (V_{SUB}) and reset gate clock voltage (V_{RGL}) to the displayed voltage. Fluctuation range after adjustment is ±3%.

V_{SUB} code address—1 digit display
 V_{RGL} code address—1 digit display

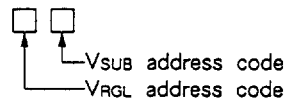

Code addresses and actual numerical values correspond to each other as follows.

V _{RGL} address code	1	2	3	4	5	6	7
Numerical value	1.0	1.5	2.0	2.5	3.0	3.5	4.0

V _{SUB} address code	E	f	G	h	J	K	L	m	N	P	Q	R	S	T	U	V	W	X	Y	Z
Numerical value	9.0	9.5	10.0	10.5	11.0	11.5	12.0	12.5	13.0	13.5	14.0	14.5	15.0	15.5	16.0	16.5	17.0	17.5	18.0	18.5

<Example> "5L" → V_{RGL}=3.0V
 V_{SUB}=12.0V

*3 V_L setting is the V_{VL} voltage of the vertical transfer clock waveform.

- * 4
1. Current to each pin when 18V is applied to V_{DD} , V_{out} , V_{SS} and SUB pins, while pins that are not tested are grounded.
 2. Current to each pins when 20V is applied sequentially to $V_{\phi 1}$, $V_{\phi 2}$, $V_{\phi 3}$ and $V_{\phi 4}$, while pins that are not tested are grounded. However, 20V is applied to SUB.
 3. Current to each pins when 15V is applied sequentially to pins RG, $H_{\phi 1}$, $H_{\phi 2}$ and V_{GG} , while pins that are not tested are grounded. However, 15V is applied to SUB.
 4. Apply 30V to Pins $V_{\phi 1}$, $V_{\phi 2}$, $V_{\phi 3}$, $V_{\phi 4}$, V_{DD} , V_{out} ; 24V to Pin RG; and 20V to Pins V_{GG} , V_{SS} , $H_{\phi 1}$, $H_{\phi 2}$. The above is the current that flows to Pin V_L when it is grounded. Please note that Pins GND and SUB are to be disconnected.
- * 5 Current to SUB pin when 55V is applied to SUB pin, while pins that are not tested are grounded.

Clock Voltage Conditions

Item	Symbol	Min.	Typ.	Max.	Unit	Waveform diagram	Remarks
Read out clock voltage	V_{VT}	14.55	15.0	15.45	V	1	
Vertical transfer clock voltage	V_{VH1} , V_{VH2}	-0.05	0	0.05	V	2	$V_{VH}=(V_{VH1}+V_{VH2})/2$
	V_{VH3} , V_{VH4}	-0.2	0	0.05	V	2	
	V_{VL1} , V_{VL2} , V_{VL3} , V_{VL4}	-9.0	-8.5	-8.0	V	2	$V_{VL}=(V_{VL3}+V_{VL4})/2$
	$V_{\phi v}$	7.8	8.5	9.05	V	2	$V_{\phi v}=V_{VHN}-V_{VLN}$ ($n=1$ to 4)
	$ V_{VH1}-V_{VH2} $			0.1	V	2	
	$V_{VH3}-V_{VH}$	-0.25		0.1	V	2	
	$V_{VH4}-V_{VH}$	-0.25		0.1	V	2	
	V_{VHH}			0.5	V	2	High level coupling
	V_{VHL}			0.5	V	2	High level coupling
	V_{VLH}			0.5	V	2	Low level coupling
V_{VLL}			0.5	V	2	Low level coupling	
Horizontal transfer clock voltage	$V_{\phi H}$	4.75	5.0	5.25	V	3	
	V_{HL}	-0.05	0	0.05	V	3	
Reset gate clock voltage	$V_{\phi RG}$	4.5	5.0	5.5	V	4	* 6
	$V_{RGLH}-V_{RGLL}$			0.8	V	4	Low level coupling
Substrate clock voltage	$V_{\phi SUB}$	22.5	23.5	24.5	V	5	

- * 6 No adjustment of reset gate clock voltage is necessary when reset gate clock is driven as indicated below. In this case, reset gate clock voltage set point displayed on back of image sensor has no meaning.

Item	Symbol	Min.	Typ.	Max.	Unit	Waveform diagram	Remarks
Reset gate clock voltage	V_{RGL}	-0.2	0	0.2	V	4	
	$V_{\phi RG}$	8.5	9.0	9.5	V	4	

Clock Equivalent Circuit Constant

Item	Symbol	Min.	Typ.	Max.	Unit	Remarks
Capacitance between vertical transfer clock and GND	$C\phi_{V1}, C\phi_{V3}$		1000		pF	
	$C\phi_{V2}, C\phi_{V4}$		560		pF	
Capacitance between vertical transfer clocks	$C\phi_{V12}, C\phi_{V34}$		470		pF	
	$C\phi_{V23}, C\phi_{V41}$		330		pF	
	$C\phi_{V13}$		220		pF	
	$C\phi_{V24}$		100		pF	
Capacitance between horizontal transfer clock and GND	$C\phi_{H1}, C\phi_{H2}$		47		pF	
Capacitance between horizontal transfer clocks	$C\phi_{HH}$		43		pF	
Capacitance between reset gate clock and GND	$C\phi_{RG}$		8		pF	
Capacitance between substrate clock and GND	$C\phi_{SUB}$		270		pF	
Vertical transfer clock serial resistor	R_1, R_2, R_3, R_4		80		Ω	
Vertical transfer clock ground resistor	R_{GND}		15		Ω	
Horizontal transfer clock serial resistor	$R\phi_H$		15		Ω	

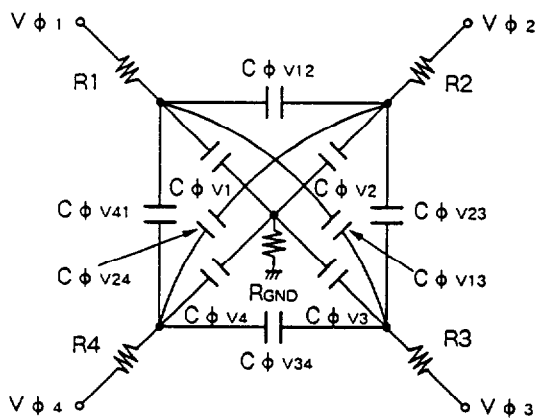

Vertical transfer clock equivalent circuit

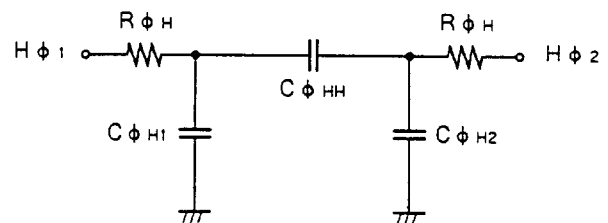

Horizontal transfer clock equivalent circuit

Drive Clock Waveform Conditions

(1) Read out clock waveform

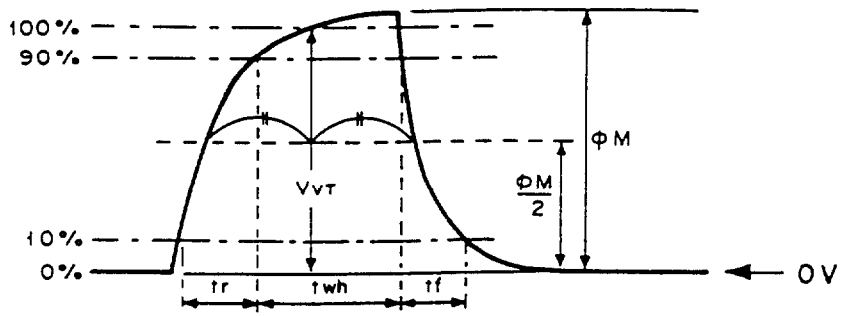

(2) Vertical transfer clock waveform

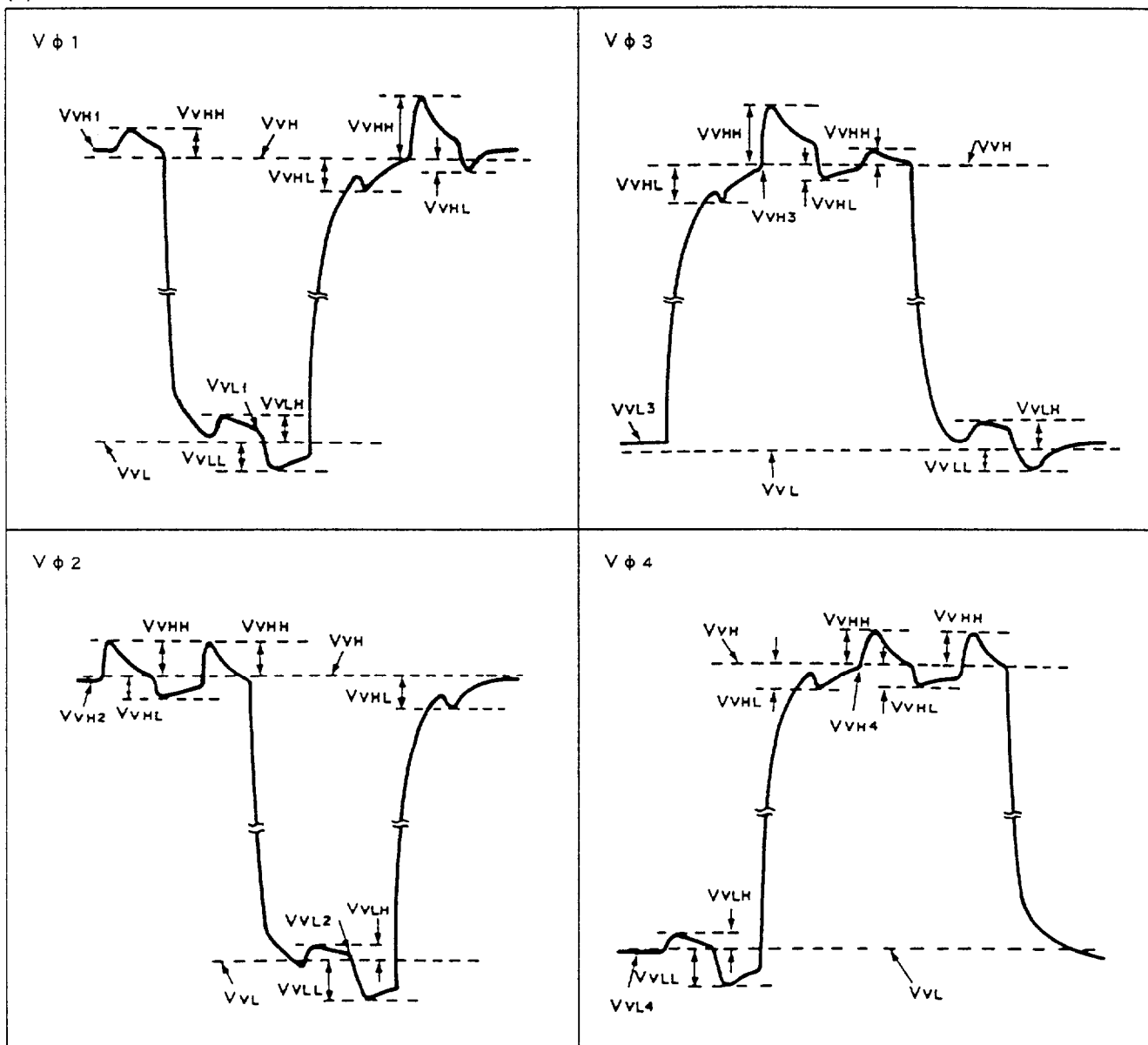

$$V_{VH} = \frac{V_{VH1} + V_{VH2}}{2}$$

$$V_{VL} = \frac{V_{VL3} + V_{VL4}}{2}$$

$$V_{\phi V} = V_{VHn} - V_{VLn} \quad (n=1 \text{ to } 4)$$

(3) Horizontal transfer clock waveform diagram

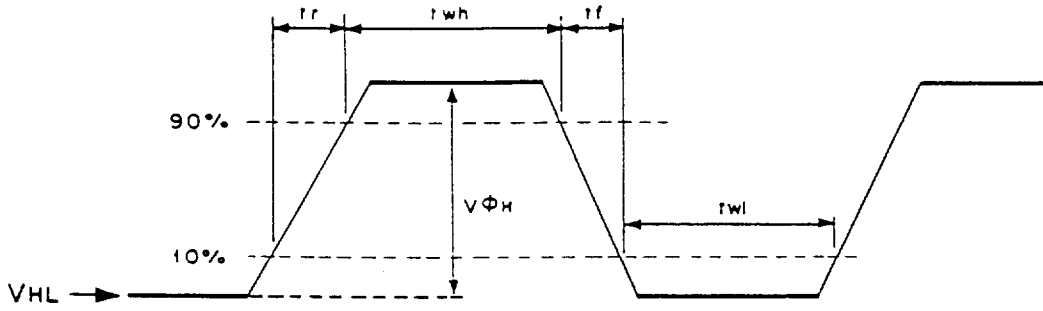

(4) Reset gate clock waveform diagram

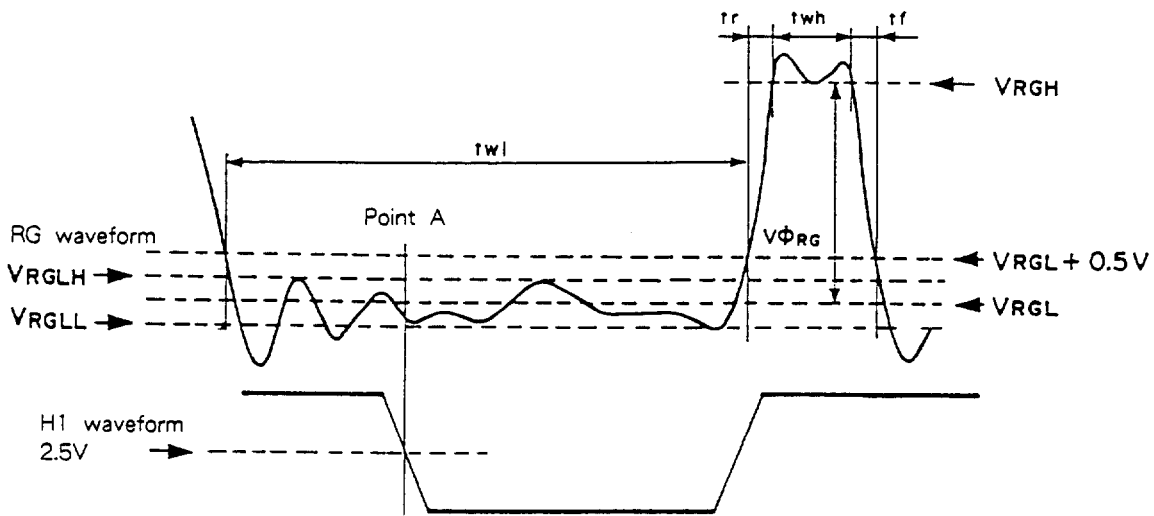

V_{RGLH} is the maximum value and V_{RGLL} the minimum value of the coupling waveform in the period from Point A in the diagram above to RG rise.

V_{RGL} is the mean value for V_{RGLH} and V_{RGLL} .

$$V_{RGL} = (V_{RGLH} + V_{RGLL}) / 2$$

V_{RGH} is the minimum value for t_{wh} period.

$$V_{\phi RG} = V_{RGH} - V_{RGL}$$

(5) Substrate clock waveform

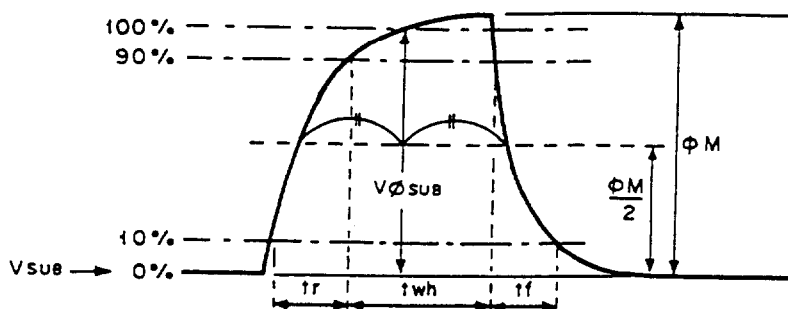

Clock Switching Characteristics

Item	Symbol	twh			twl			tr			tf			Unit	Remarks
		Min.	Typ.	Max.	Min.	Typ.	Max.	Min.	Typ.	Max.	Min.	Typ.	Max.		
Read out clock	V_T	2.3	2.5						0.5			0.5		μs	During read out
Vertical transfer clock	$V_{\phi 1}, V_{\phi 2}, V_{\phi 3}, V_{\phi 4}$										15		250	ns	* 7
Horizontal transfer clock	During imaging	$H_{\phi 1}$	18	24		19.5	26		10	17.5		10	17.5	ns	* 8
		$H_{\phi 2}$	21	26		19	24		10	15		10	15	ns	
	During parallel serial conversion	$H_{\phi 1}$		5.38					0.01			0.01		μs	
		$H_{\phi 2}$					5.38		0.01			0.01		μs	
Reset gate clock	ϕ_{RG}	11	13			51		3			3		ns		
Substrate clock	ϕ_{SUB}	1.5	1.8						0.5			0.5	μs	During charge drain.	

* 7 When vertical transfer clock driver CXD1250 is in use.

* 8 $t_f \geq t_r - 2 \text{ ns}$, and the crosspoint voltage (V_{CP}) of the $H_{\phi 1}$ rise side of waveforms $H_{\phi 1}$ and $H_{\phi 2}$ must be at least 2.5V.

Item	Symbol	two			Unit	Remarks
		Min.	Typ.	Max.		
Horizontal transfer clock	$H_{\phi 1}, H_{\phi 2}$	16	20		ns	* 9

* 9 "two" is the overlap period of horizontal transfer clocks $H_{\phi 1}$ and $H_{\phi 2}$'s twh and twl.

Operating Characteristics

(Ta=25°C)

Item	Symbol	Min.	Typ.	Max.	Unit	Test method	Remarks
Sensitivity	S	270	340		mV	1	
Saturation signal	Ysat	600			mV	2	Ta=60°C
Smear	Sm		0.009	0.015	%	3	
Video signal shading	SHy			20	%	4	Zone 0, I
				25	%	4	Zone 0 to II'
Uniformity between signal channels	ΔSr			10	%	5	
	ΔSb			10	%	5	
Dark signal	Ydt			2	mV	6	Ta=60°C
Dark signal shading	ΔYdt			1	mV	7	Ta=60°C
Flicker Y	Fy			2	%	8	
Flicker R-Y	Fcr			5	%	8	
Flicker B-Y	Fcb			5	%	8	
Horizontal stripes R	Lcr			3	%	9	
Horizontal stripes G	Lcg			3	%	9	
Horizontal stripes B	Lcb			3	%	9	
Horizontal stripes W	Lcw			3	%	9	
Lag	Lag			0.5	%	10	

Zone chart of Video signal shading

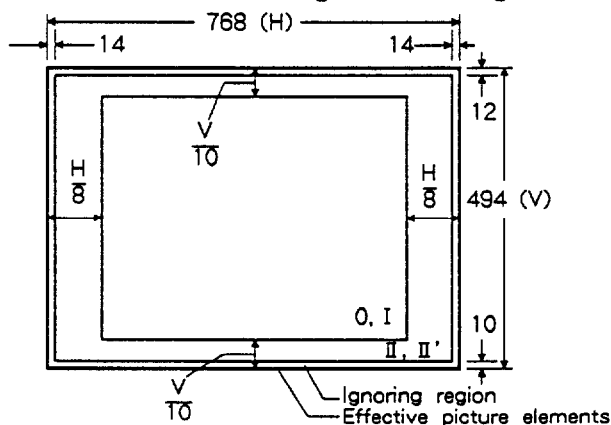

Testing System

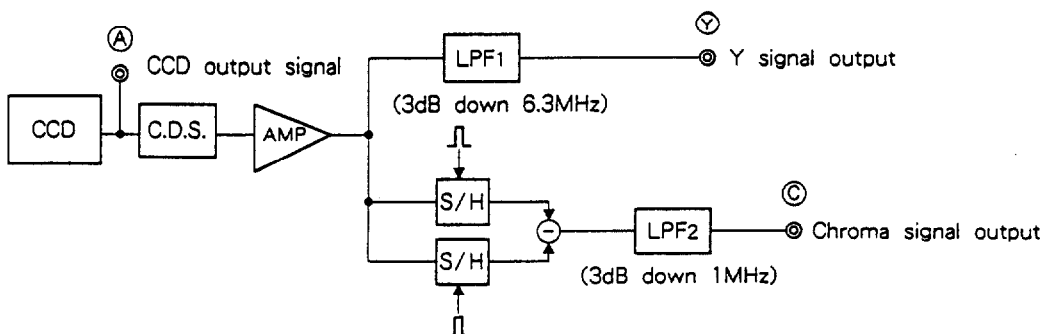

Note) Adjust AMP amplifier so that total gains between (A) and (Y) and between (A) and (C) equal 1.

Image Sensor Characteristics Test Method

⊙ **Test conditions**

- ① Through the following tests the substrate voltage and reset gate clock voltage are set to the value displayed on the device, while the device drive conditions are at the typical value of the bias and clock voltage conditions.
- ② Through the following tests defects are excluded and, unless otherwise specified, the optical black level (Hence forth referred to as OB) is set as the reference for the signal output which is taken as the Y signal output or the chroma signal output of the testing system.

⊙ **Color coding of CFA (Color Filter Array) & Composition of luminance (Y) and chrominance (C) signals**

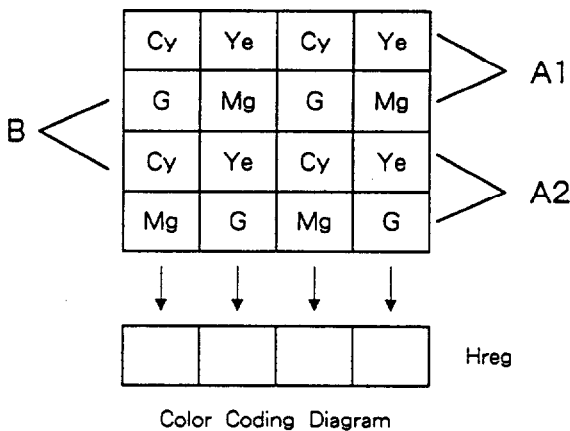

CFA of this image sensor is shown in the Figure. This complementary CFA is used with a "field integration mode", where all of the photosites are read out during each video field. Signals from two vertically adjacent photosites, such as line A1 or A2 for field A, are summed when the image charge is transferred into the vertical storage columns. The read out line pairing is shifted down one line for field B. The sensor output signals through the horizontal register (H reg.) at line A1 are [G+Cy], [Mg+Ye], [G+Cy], [Mg+Ye].

These signals are processed in order to compose Y and C signals. By adding the two adjacent signals at line A1, Y signal is formed as follows:

$$Y = \{(G+Cy) + (Mg+Ye)\} \times 1/2$$

$$= 1/2 \{2B + 3G + 2R\}$$

C signal is composed by subtracting the two adjacent signals at line A1.

$$R - Y = \{(Mg+Ye) - (G+Cy)\}$$

$$= \{2R - G\}$$

Next, the signals through H reg. at line A2 are

$$[Mg+Cy], [G+Ye], [Mg+Cy], [G+Ye]$$

Similarly, Y and C signals are composed at line A2.

$$Y = \{(G+Ye) + (Mg+Cy)\} \times 1/2$$

$$= 1/2 \{2B + 3G + 2R\}$$

$$-(B-Y) = \{(G+Ye) - (Mg+Cy)\}$$

$$= -\{2B - G\}$$

Accordingly, Y signal is balanced in relation to the scanning lines, and C signal takes the form of R-Y and -(B-Y) on alternate lines.

It is the same for B field.

◎ Definition of standard imaging conditions

- ① Standard imaging condition I: (As imaging device) Use a pattern box (luminance 706 cd/m², color temperature 3200K Halogen source) as a subject. (Pattern for evaluation is not applicable.) Use a testing standard lens with CM500S (t=1.0mm) as IR cut filter and image at F5.6. At this time, light intensity to sensor receiving surface is defined as standard sensitivity testing light intensity.
- ② Standard imaging condition II: Image a light source (color temperature of 3200K) which uniformity of brightness is within 2% at all angles. Use a testing standard lens with CM500S (t=1.0mm) as IR cut filter. The light intensity is adjusted to the value indicated in each testing item by lens diaphragm.

1. Sensitivity

Set to standard image condition I. After selecting the electronic shutter mode at a 1/250s. shutter speed, measure the Y signal (Y_s) at the center of the screen and substitute in the following formula.

$$S = Y_s \times \frac{250}{60} \text{ [mV]}$$

2. Saturation signal

Set to standard imaging condition II. Adjust light intensity to 10 times that of Y signal output average value (Y_A=200mV), then test Y signal minimum value.

3. Smear

Set to standard imaging condition II. Adjust light intensity to 500 times that of Y signal output average value (Y_A=200mV) with lens diaphragm at F5.6 to F8. Stop read out clock. When the charge drain executed by the electronic shutter at the respective H blankings takes place, test the maximum value Y_{Sm} [mV] of Y signal output.

$$S_m = \frac{Y_{Sm}}{200} \times \frac{1}{500} \times \frac{1}{10} \times 100 \text{ (%) (1/10V)}$$

4. Video signal shading

Set to standard imaging condition II. Adjust light intensity to Y signal output average value (Y_A=200mV) with lens diaphragm at F5.6 to F8. Then test maximum (Y_{max} [mV]) and minimum (Y_{min} [mV]) values of Y signal.

$$S_{Hy} = (Y_{max} - Y_{min}) / 200 \times 100 \text{ (%)}$$

5. Video signal between channels uniformity

Set to standard imaging condition II. Adjust light intensity to Y signal output average value (Y_A=200mV). Then test maximum (C_{rmax}, C_{bmax} [mV]) and minimum (C_{rmin}, C_{bmin} [mV]) values of chroma signals from R-Y and B-Y channels.

$$\Delta S_r = |(C_{rmax} - C_{rmin}) / 200| \times 100 \text{ (%)}$$

$$\Delta S_b = |(C_{bmax} - C_{bmin}) / 200| \times 100 \text{ (%)}$$

6. Dark signal

Test Y signal output average value Y_{dt} [mV] when the device ambient temperature is at 60 °C and light is obstructed with horizontal idle transfer level as reference.

7. Dark signal shading

Following 6, test maximum (Y_{dmax} [mV]) and minimum (Y_{dmin} [mV]) values of dark signal output.

$$\Delta Y_{dt} = Y_{dmax} - Y_{dmin} \text{ [mV]}$$

8. Flicker

① Fy

Set to standard imaging condition II. Adjust light intensity to Y signal output average value (YA=200mV). Then test the Y signal difference (Δ Yf [mV]) between even field and odd field.

$$F_y = (\Delta Y_f / 200) \times 100 (\%)$$

② Fcr, Fcb

Set to standard imaging condition II. Adjust light intensity to Y signal output average value (YA=200mV). Then insert R or B filter, and test the C signal difference (Δ Cr, Δ Cb) between even field and odd field and the C signal output average value (CAr, CAb).

$$F_{ci} = (\Delta C_i / C_{Ai}) \times 100 (\%) \quad (i=r, b)$$

9. Lateral stripe

Set to standard imaging condition II. Adjust light intensity to Y signal output average value (YA=200mV). Then insert R, G and B filters respectively, and test the signal difference (Δ Ylw, Δ Ylr, Δ Ylg, Δ Ylb [mV]) between Y signal lines of the same field.

$$L_{ci} = (\Delta Y_{li} / 200) \times 100 (\%) \quad (i=w, r, g, b)$$

10. Residual image

Adjust Y signal output value by strobe light to 200mV. Then light a stroboscopic tube with the following timing and test the residual image (Ylag).

$$Lag = (Y_{lag} / 200) \times 100 (\%)$$

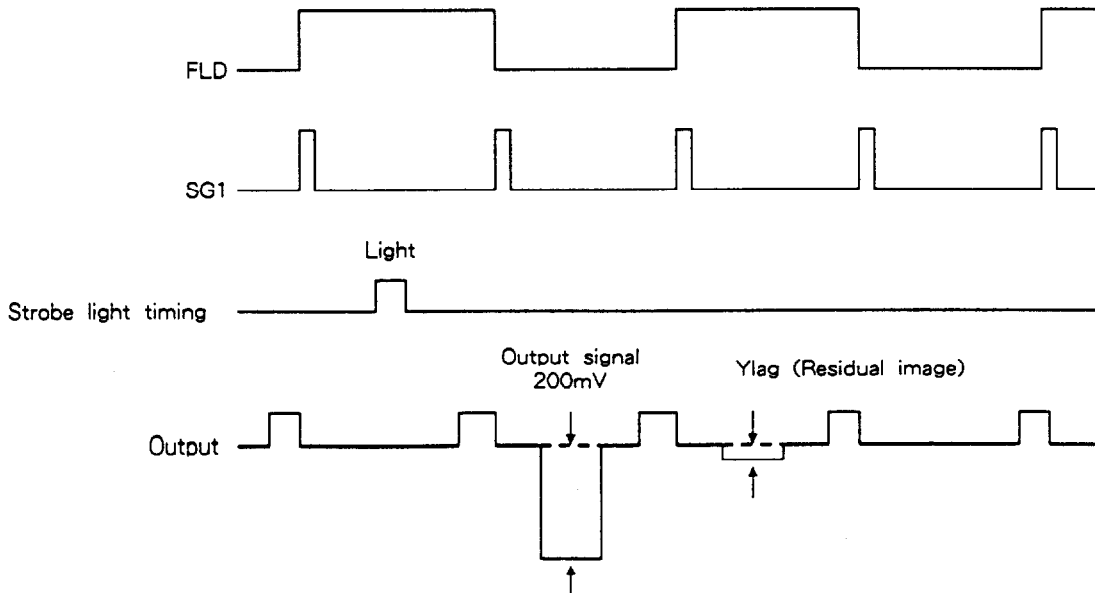

Drive Circuit

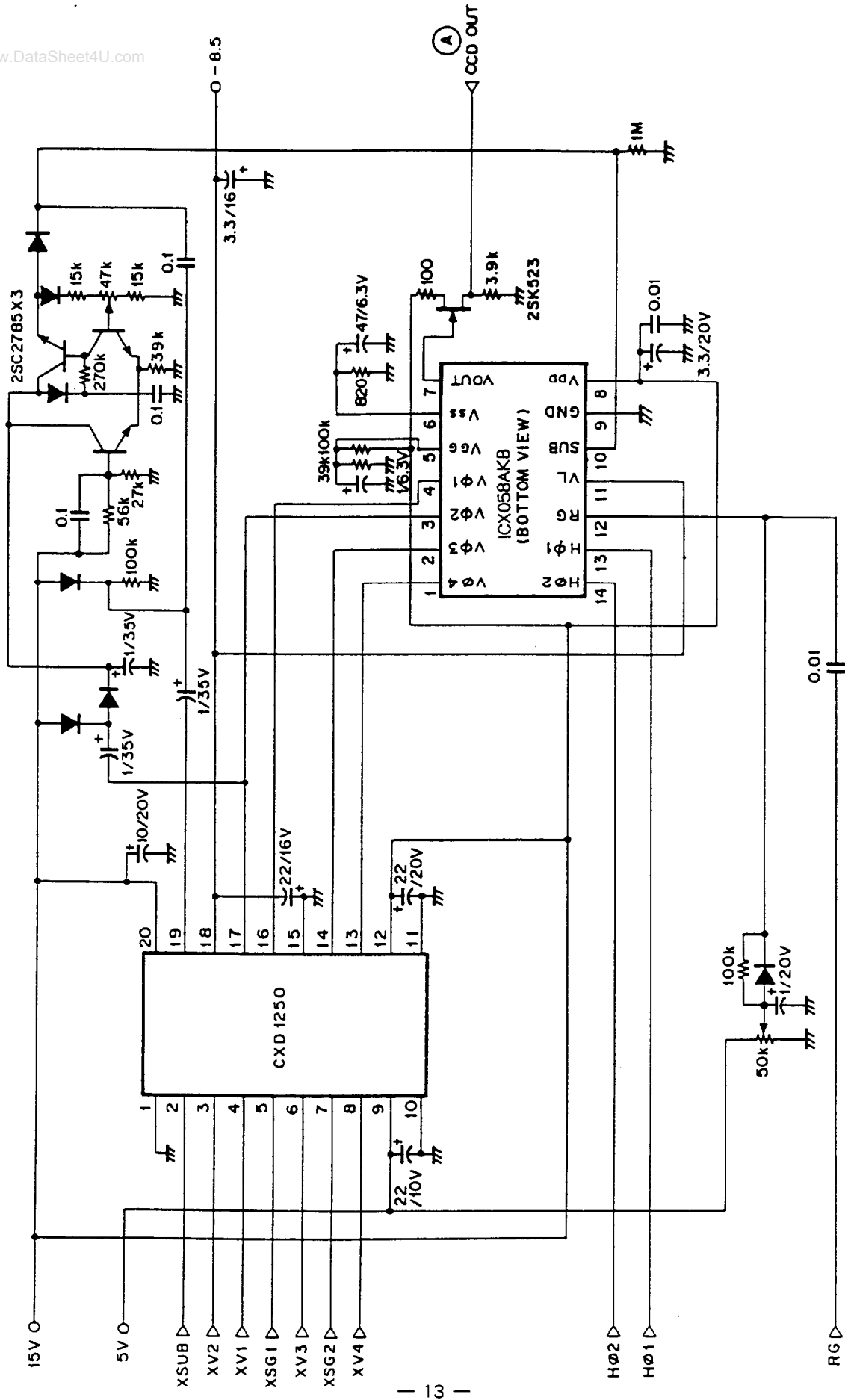

Spectral Sensitivity Characteristics

(Excluding light source characteristics, including lens characteristics)

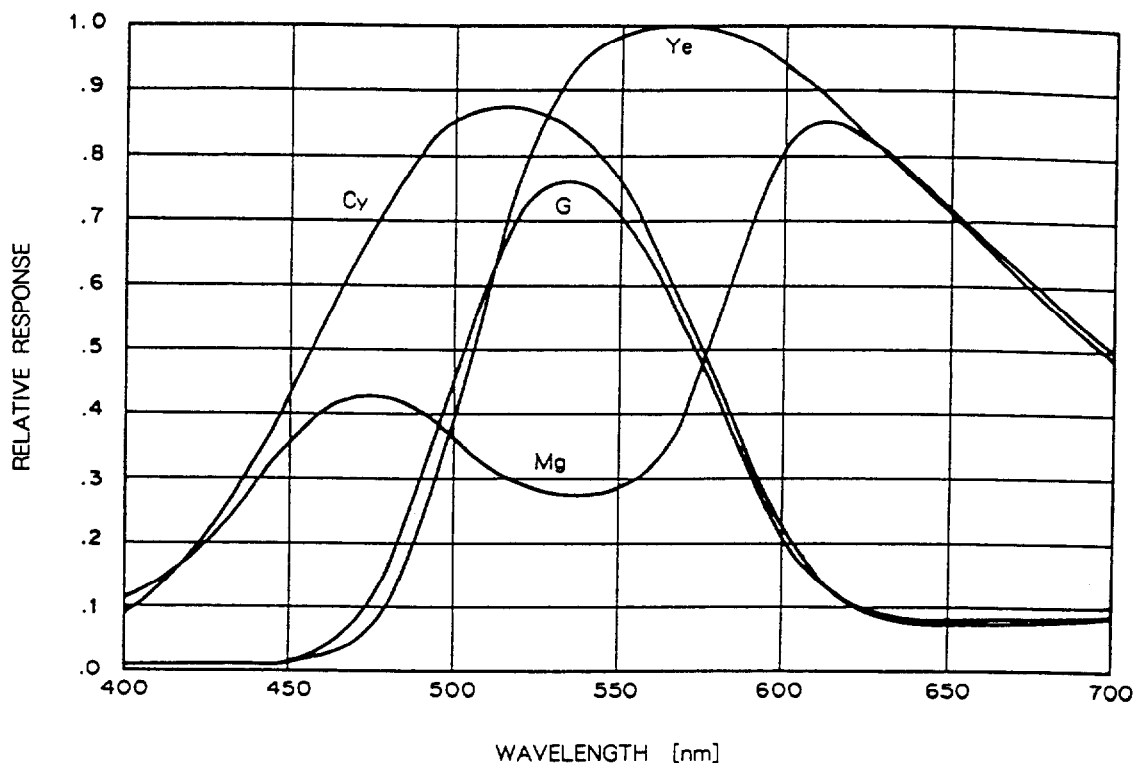

Using Read Out Clock Timing Chart

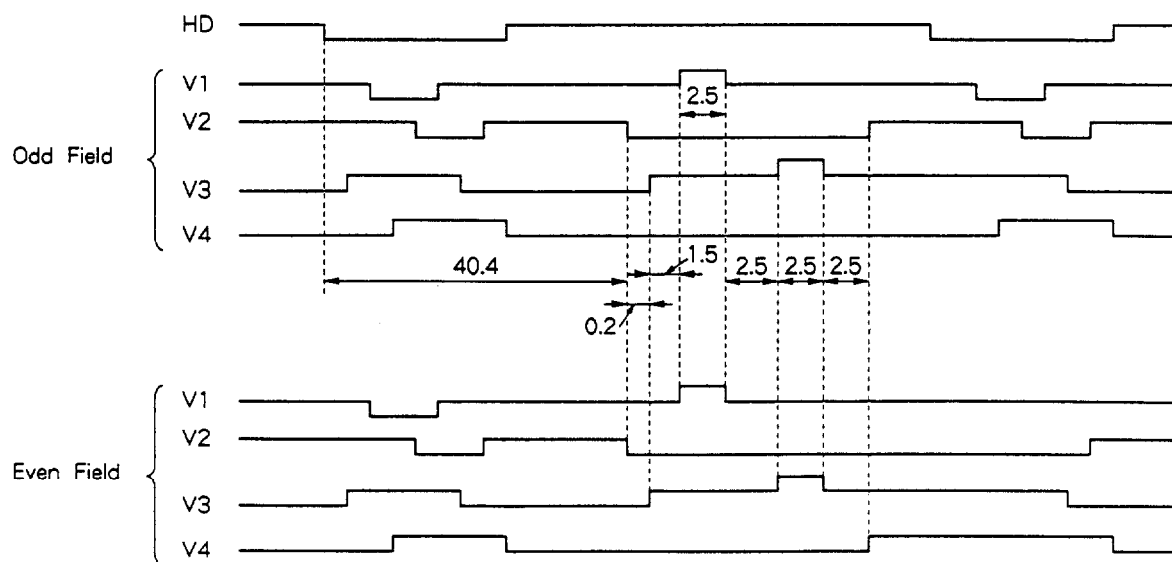

Unit : μ s

www.DataSheet4U.com

Drive Timing Chart (Vertical sync)

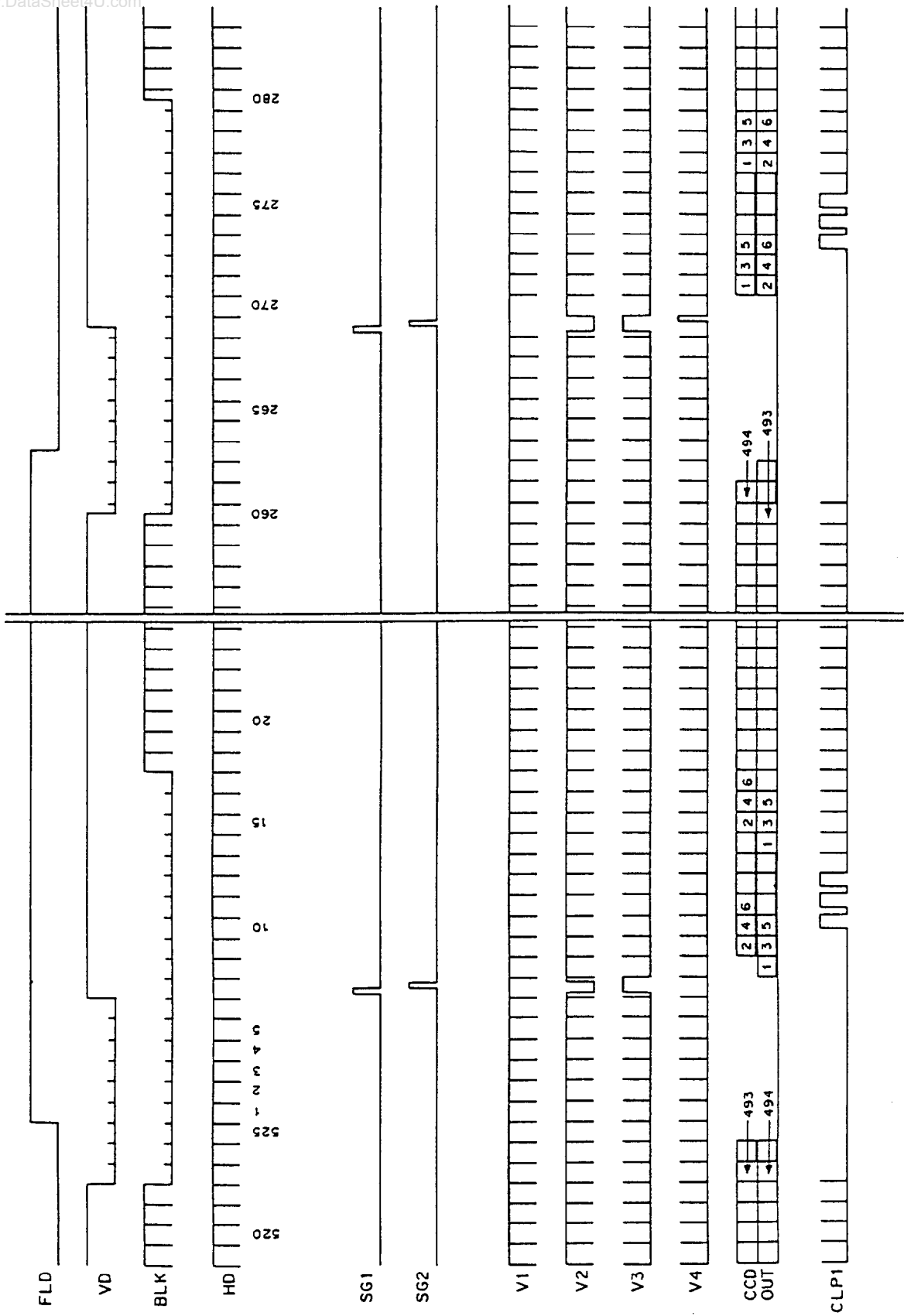

Drive Timing Chart (Horizontal sync)

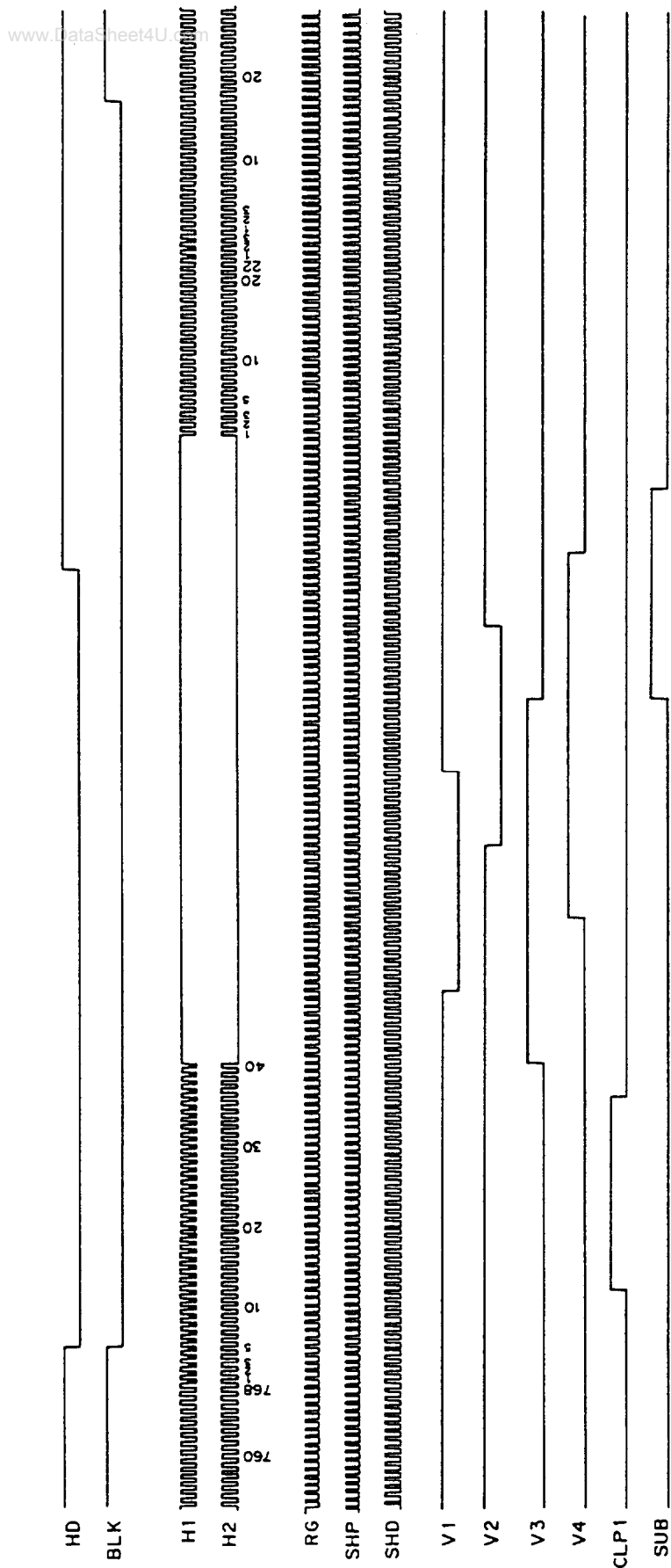

Notes on Handling

1) Static charge prevention

CCD image sensors are easily damaged by static discharge. Before handling be sure to take the following protective measures.

- a) Either handle bare handed or use non-chargeable gloves, clothes or material.
Also use conductive shoes.
- b) When handling directly use an earth band.
- c) Install a conductive mat on the floor or working table to prevent the generation of static electricity.
- d) Ionized air is recommended for discharge when handling CCD image sensor.
- e) For the shipment of mounted substrates, use boxes treated for the prevention of static charges.

2) Soldering

- a) Make sure the package temperature does not exceed 80°C.
- b) Solder dipping in a mounting furnace causes damage to the glass and other defects. Use a ground 30W soldering iron and solder each pin in less than 2 seconds. For repairs and remount, cool sufficiently.
- c) To dismount an image sensor, do not use a solder suction equipment. When using an electric desoldering tool, use a thermal controller of the zero cross On/Off type and connect it to ground.

3) Dust and dirt protection

Image sensors are packed and delivered by taking care of protecting its glass plates from harmful dust and dirt. Clean glass plates with the following operation as required, and use them.

- a) Operate in clean environments (around class 1000 is appropriate).
 - b) Do not either touch glass plates by hand or have any object come in contact with glass surfaces. Should dirt stick to a glass surface, blow it off with an air blower. (For dirt stuck through static electricity ionized air is recommended.)
 - c) Clean with a cotton bud and ethyl alcohol if the grease stained. Be careful not to scratch the glass.
 - d) Keep in a case to protect from dust and dirt. To prevent dew condensation, preheat or precool when moving to a room with great temperature differences.
 - e) When a protective tape is applied before shipping, just before use remove the tape applied for electrostatic protection. Do not reuse the tape.
- 4) Do not expose to strong light (sun rays) for long periods, color filters will be discolored. For continuous using under cruel condition exceeding the normal using condition, consult our company.
 - 5) Exposure to high temperature or humidity will affect the characteristics. Accordingly avoid storage or usage in such conditions.
 - 6) CCD image sensors are precise optical equipment that should not be subject to too much mechanical shocks.
 - 7) Eclipse (to get dark around the four corners of the picture) may occur when some object lenses are in the open iris state.

External Appearance

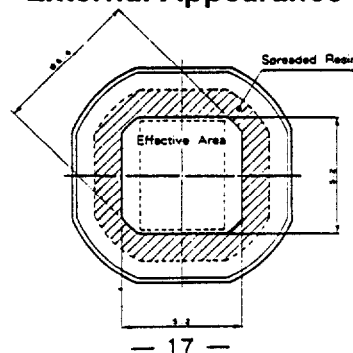

Package Outline

Unit: mm

14pin DIP (200mil)

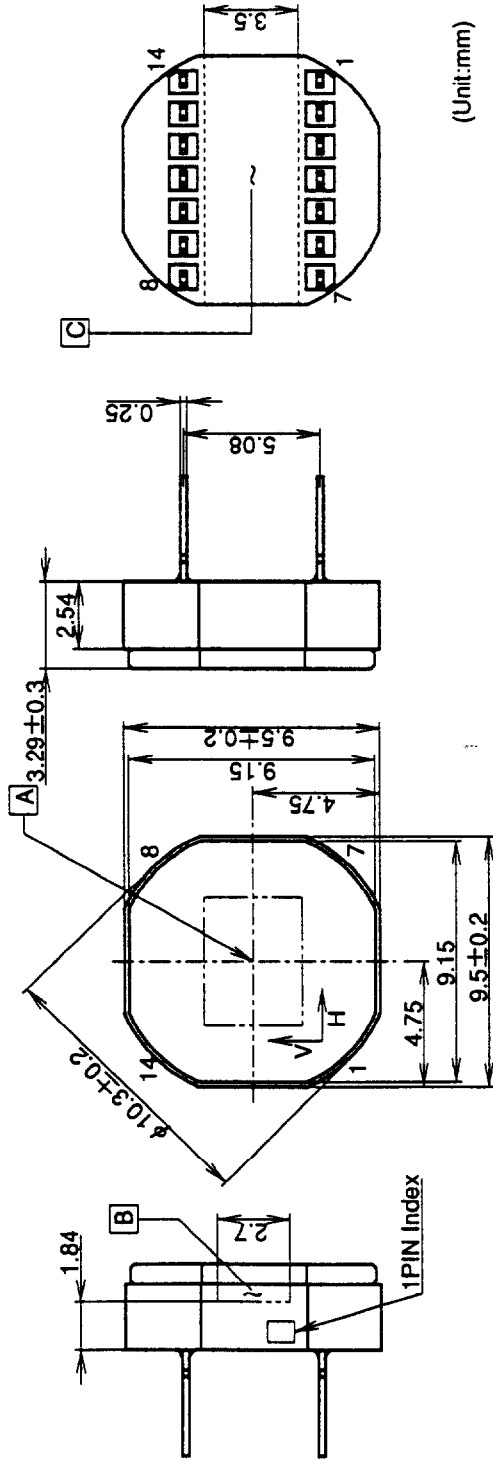

1. Aは有効撮像エリアの中心
 2. 水平方向の基準はパッケージ側面B
 3. 垂直方向の基準はパッケージ側面B'
 4. 高さ方向の基準はパッケージ底面C
 5. パッケージ中心に対する有効撮像エリアの中心位置度公差±0.15mm
 6. H、V方向に対する有効撮像面の回転精度：±1°
 7. 底面Cから有効撮像面までの高さ：1.41±0.15mm
 8. 底面Cに対する有効撮像面のアオリ：60μm以下
 9. シールガラスの厚さは0.75mm（実寸）、屈折率は1.5
- *パッケージ中心：パッケージ側面B、B'にそれぞれ対向し合う2組の端子の端面により得られる中心点

1. "A" is the center of the effective image area.
 2. The point "B" of the package is the horizontal reference.
 3. The point "B'" of the package is the vertical reference.
 4. The bottom "C" of the package is the height reference.
 5. The center of the effective image area relative to the center of the package(*) is (H, V) ±(0.0)±0.15mm.
 6. The rotation angle of the effective image area relative to H and V is ±1°.
 7. The height from the bottom "C" to the effective image area is 1.41±0.15mm.
 8. The tilt of the effective image area relative to the bottom "C" is less than 60μm.
 9. The thickness of the cover glass is 0.75mm, and the refractive index is 1.5.
- *Center of the package: The center is halfway between two pairs of opposite sides, as measured from "B", "B'".

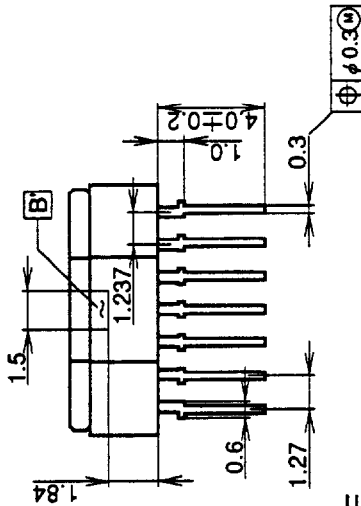

PACKAGE STRUCTURE

PACKAGE MATERIAL	Ceramic
LEAD TREATMENT	GOLD PLATING
LEAD MATERIAL	42 ALLOY
PACKAGE WEIGHT	0.6g