

Diagonal 4.5mm (Type 1/4) CCD Image Sensor for PAL Color Video Cameras

Description

The ICX229AKB is an interline CCD solid-state image sensor suitable for PAL color video cameras. Compared with the current product ICX209AKB, smear characteristics are improved drastically and power consumption is reduced. Ye, Cy, Mg, and G complementary color mosaic filters are used. High sensitivity and high saturation signal are achieved by Super HAD CCD technology.

This chip features a field period readout system and an electronic shutter with variable charge-storage time.

Also, this outline is miniaturized by using original package.

Features

- Maximum package dimensions: $\phi 8\text{mm}$
- Low smear (-100dB Typ.at F5.6)
- Low power consumption (-38% compared with ICX209AKB)
- High sensitivity ($+3\text{dB}$ at F1.2 compared with ICX209AKB)
- High saturation signal
- Supply voltage: 12V
- Horizontal register: 3.3V drive
- Reset gate: 3.3V drive
- No voltage adjustment
(Reset gate and substrate bias are not adjusted.)
- High resolution, low dark current
- Excellent antiblooming characteristics
- Continuous variable-speed shutter
- Recommended range of exit pupil distance: -20 to -100mm
- Ye, Cy, Mg, and G complementary color mosaic filters on chip

Device Structure

- Interline CCD image sensor
- Image size: Diagonal 4.5mm (Type 1/4)
- Number of effective pixels: $752\text{ (H)} \times 582\text{ (V)}$ approx. 440K pixels
- Total number of pixels: $795\text{ (H)} \times 596\text{ (V)}$ approx. 470K pixels
- Chip size: $4.34\text{mm (H)} \times 3.69\text{mm (V)}$
- Unit cell size: $4.85\mu\text{m (H)} \times 4.65\mu\text{m (V)}$
- Optical black: Horizontal (H) direction: Front 3 pixels, rear 40 pixels
Vertical (V) direction: Front 12 pixels, rear 2 pixels
- Number of dummy bits: Horizontal 22
Vertical 1 (even fields only)
- Substrate material: Silicon

Sony reserves the right to change products and specifications without prior notice. This information does not convey any license by any implication or otherwise under any patents or other right. Application circuits shown, if any, are typical examples illustrating the operation of the devices. Sony cannot assume responsibility for any problems arising out of the use of these circuits.

13 pin PCA (Ceramic)

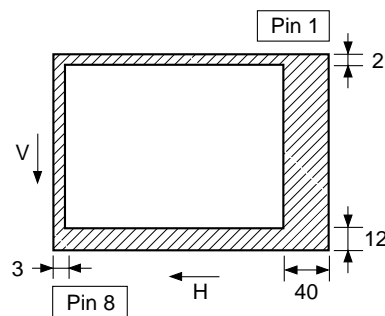
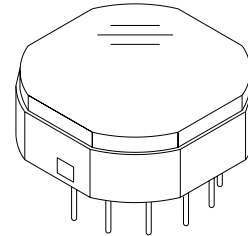

Optical black position
(Top View)

Block Diagram and Pin Configuration

(Top View)

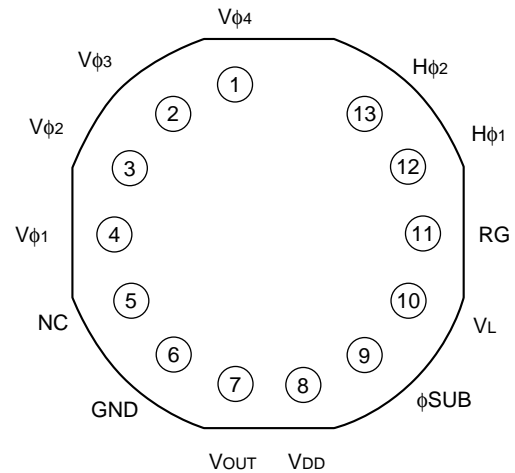
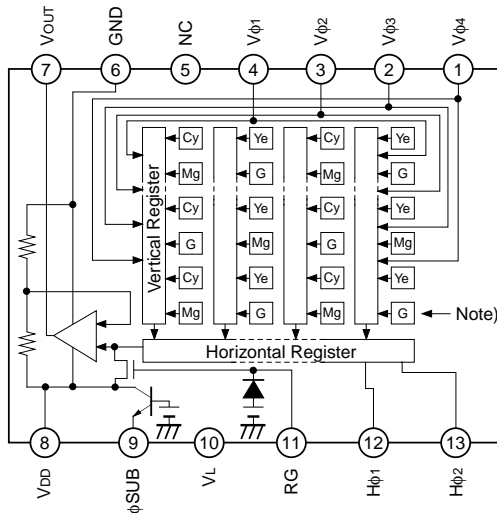

Pin Description

| Pin No. | Symbol | Description | Pin No. | Symbol | Description |
|---------|-----------|----------------------------------|---------|--------------|------------------------------------|
| 1 | $V\phi_4$ | Vertical register transfer clock | 8 | V_{DD} | Supply voltage |
| 2 | $V\phi_3$ | Vertical register transfer clock | 9 | ϕ_{SUB} | Substrate clock |
| 3 | $V\phi_2$ | Vertical register transfer clock | 10 | V_L | Protective transistor bias |
| 4 | $V\phi_1$ | Vertical register transfer clock | 11 | RG | Reset gate clock |
| 5 | NC | | 12 | $H\phi_1$ | Horizontal register transfer clock |
| 6 | GND | GND | 13 | $H\phi_2$ | Horizontal register transfer clock |
| 7 | V_{OUT} | Signal output | | | |

Absolute Maximum Ratings

| Item | | Ratings | Unit | Remarks |
|--------------------------|---|-------------|------|---------|
| Against ϕ_{SUB} | V_{DD} , V_{OUT} , RG – ϕ_{SUB} | -32 to +12 | V | |
| | $V\phi_1$, $V\phi_3$ – ϕ_{SUB} | -40 to +15 | V | |
| | $V\phi_2$, $V\phi_4$, V_L – ϕ_{SUB} | -40 to +0.3 | V | |
| | $H\phi_1$, $H\phi_2$, GND – ϕ_{SUB} | -32 to +0.3 | V | |
| Against GND | V_{DD} , V_{OUT} , RG – GND | -0.3 to +17 | V | |
| | $V\phi_1$, $V\phi_2$, $V\phi_3$, $V\phi_4$ – GND | -7 to +14 | V | |
| | $H\phi_1$, $H\phi_2$ – GND | -7 to +4.2 | V | |
| Against V_L | $V\phi_1$, $V\phi_3$ – V_L | -0.3 to +21 | V | |
| | $V\phi_2$, $V\phi_4$, $H\phi_1$, $H\phi_2$, GND – V_L | -0.3 to +12 | V | |
| Between input clock pins | Voltage difference between vertical clock input pins | to +12 | V | *1 |
| | $H\phi_1$ – $H\phi_2$ | -5 to +5 | V | |
| | $H\phi_1$, $H\phi_2$ – $V\phi_4$ | -12 to +12 | V | |
| Storage temperature | | -30 to +80 | °C | |
| Operating temperature | | -10 to +60 | °C | |

*1 +21V (Max.) when clock width < 10 μ s, clock duty factor < 0.1%.

Bias Conditions

| Item | Symbol | Min. | Typ. | Max. | Unit | Remarks |
|----------------------------|------------------|-------|------|-------|------|---------|
| Supply voltage | V _{DD} | 11.64 | 12.0 | 12.36 | V | |
| Protective transistor bias | V _L | *1 | | | | |
| Substrate clock | φ _{SUB} | *2 | | | | |
| Reset gate clock | φ _{RG} | *2 | | | | |

*1 V_L setting is the V_{VL} voltage of the vertical transfer clock waveform, or the same power supply as the V_L power supply for the V driver should be used.

*2 Do not apply a DC bias to the substrate clock and reset gate clock pins, because a DC bias is generated within the CCD.

DC Characteristics

| Item | Symbol | Min. | Typ. | Max. | Unit | Remarks |
|----------------|-----------------|------|------|------|------|---------|
| Supply current | I _{DD} | | 3.5 | 5.5 | mA | |

Clock Voltage Conditions

| Item | Symbol | Min. | Typ. | Max. | Unit | Waveform diagram | Remarks |
|-----------------------------------|---|-------|------|-------|------|------------------|--|
| Readout clock voltage | V _{VT} | 11.64 | 12.0 | 12.36 | V | 1 | |
| Vertical transfer clock voltage | V _{VH1} , V _{VH2} | -0.05 | 0 | 0.05 | V | 2 | V _{VH} = (V _{VH1} + V _{VH2})/2 |
| | V _{VH3} , V _{VH4} | -0.2 | 0 | 0.05 | V | 2 | |
| | V _{VL1} , V _{VL2} , V _{VL3} , V _{VL4} | -5.5 | -5.0 | -4.5 | V | 2 | V _{VL} = (V _{VL3} + V _{VL4})/2 |
| | V _{φV} | 4.3 | 5.0 | 5.55 | V | 2 | V _{φV} = V _{VHn} - V _{VLn} (n = 1 to 4) |
| | V _{VH3} - V _{VH} | -0.25 | | 0.1 | V | 2 | |
| | V _{VH4} - V _{VH} | -0.25 | | 0.1 | V | 2 | |
| | V _{VHH} | | | 0.3 | V | 2 | High-level coupling |
| | V _{VHL} | | | 0.3 | V | 2 | High-level coupling |
| | V _{VLH} | | | 0.3 | V | 2 | Low-level coupling |
| | V _{VLL} | | | 0.3 | V | 2 | Low-level coupling |
| Horizontal transfer clock voltage | V _{φH} | 3.0 | 3.3 | 3.6 | V | 3 | |
| | V _{HL} | -0.05 | 0 | 0.05 | V | 3 | |
| Reset gate clock voltage | V _{φRG} | 3.0 | 3.3 | 3.6 | V | 4 | Input through 0.1μF capacitance |
| | V _{RGLH} - V _{RGLL} | | | 0.4 | V | 4 | Low-level coupling |
| | V _{RGL} - V _{RGLm} | | | 0.5 | V | 4 | Low-level coupling |
| Substrate clock voltage | V _{φSUB} | 16.14 | 17.0 | 17.86 | V | 5 | |

Clock Equivalent Circuit Constant

| Item | Symbol | Min. | Typ. | Max. | Unit | Remarks |
|---|------------------------|------|------|------|----------|---------|
| Capacitance between vertical transfer clock and GND | $C\phi V1, C\phi V3$ | | 1200 | | pF | |
| | $C\phi V2, C\phi V4$ | | 680 | | pF | |
| Capacitance between vertical transfer clocks | $C\phi V12, C\phi V34$ | | 220 | | pF | |
| | $C\phi V23, C\phi V41$ | | 150 | | pF | |
| | $C\phi V13$ | | 82 | | pF | |
| | $C\phi V24$ | | 75 | | pF | |
| Capacitance between horizontal transfer clock and GND | $C\phi H1, C\phi H2$ | | 22 | | pF | |
| Capacitance between horizontal transfer clocks | $C\phi HH$ | | 36 | | pF | |
| Capacitance between reset gate clock and GND | $C\phi RG$ | | 5 | | pF | |
| Capacitance between substrate clock and GND | $C\phi SUB$ | | 180 | | pF | |
| Vertical transfer clock series resistor | $R1, R2, R3, R4$ | | 82 | | Ω | |
| Vertical transfer clock ground resistor | R_{GND} | | 15 | | Ω | |
| Horizontal transfer clock series resistor | $R\phi H$ | | 12 | | Ω | |
| Reset gate clock series resistor | $R\phi RG$ | | 51 | | Ω | |

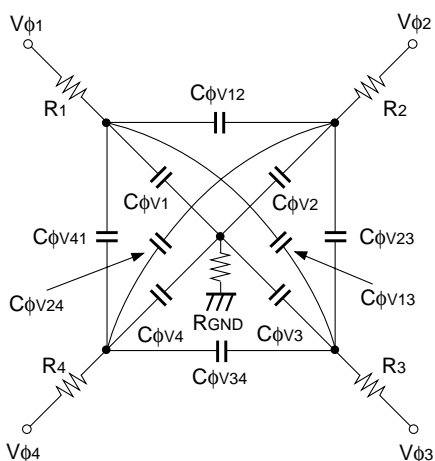

Vertical transfer clock equivalent circuit

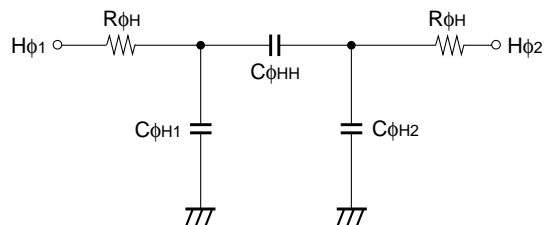

Horizontal transfer clock equivalent circuit

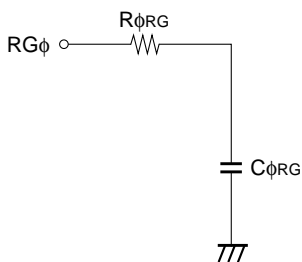

Reset gate clock equivalent circuit

Drive Clock Waveform Conditions

(1) Readout clock waveform

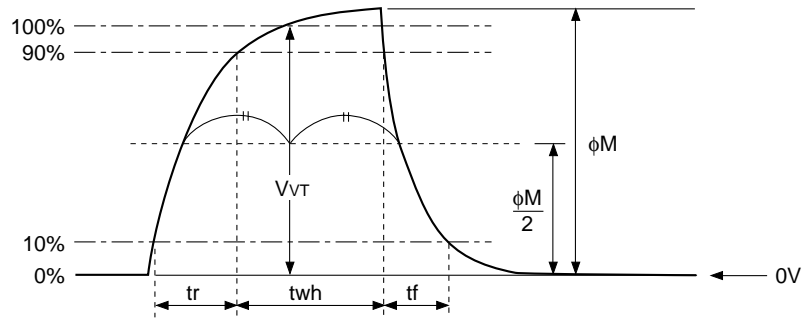

(2) Vertical transfer clock waveform

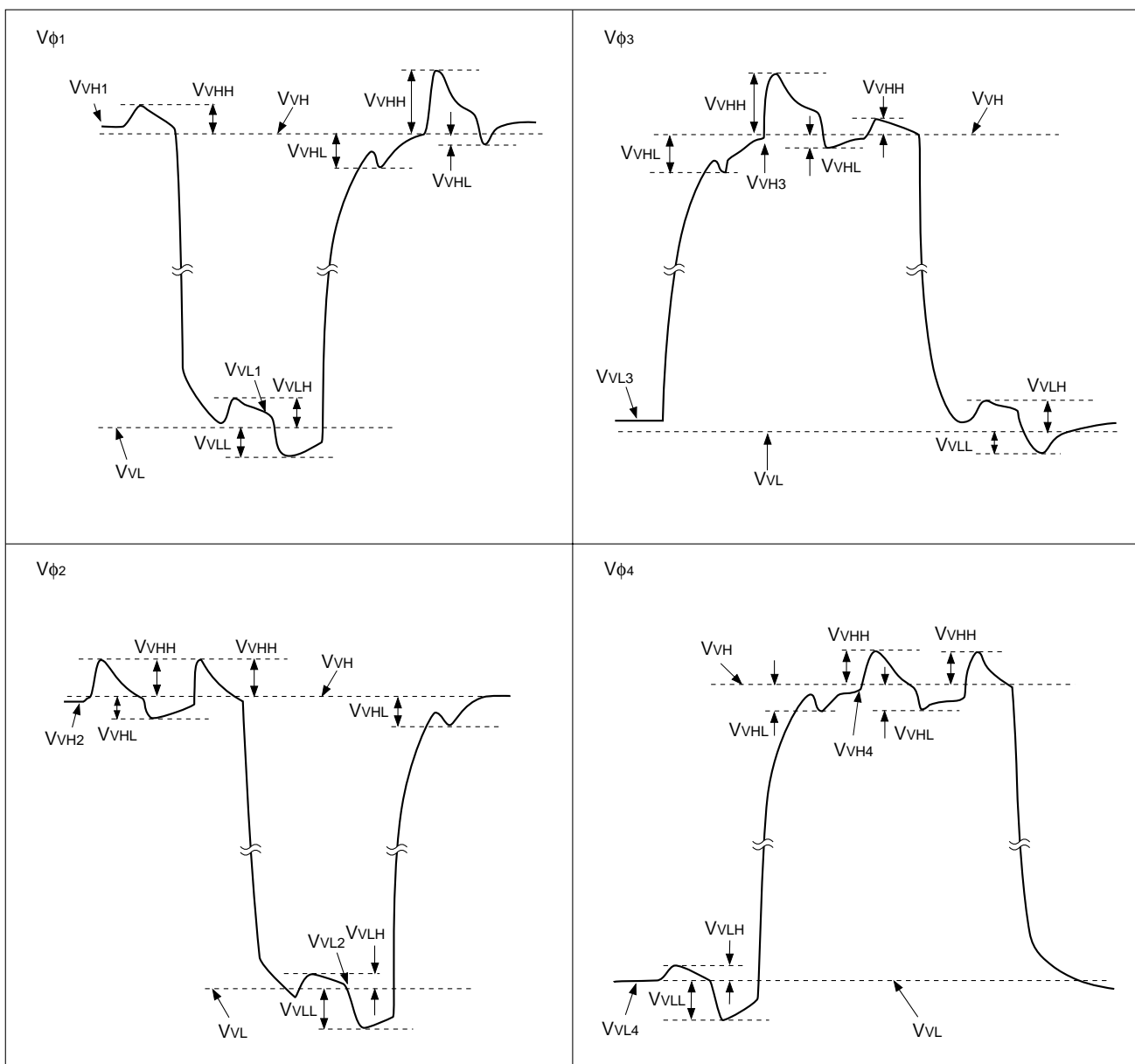

$$V_{VH} = (V_{VH1} + V_{VH2})/2$$

$$V_{VL} = (V_{VL3} + V_{VL4})/2$$

$$V_{\phi V} = V_{VHN} - V_{VLN} \quad (n = 1 \text{ to } 4)$$

(3) Horizontal transfer clock waveform

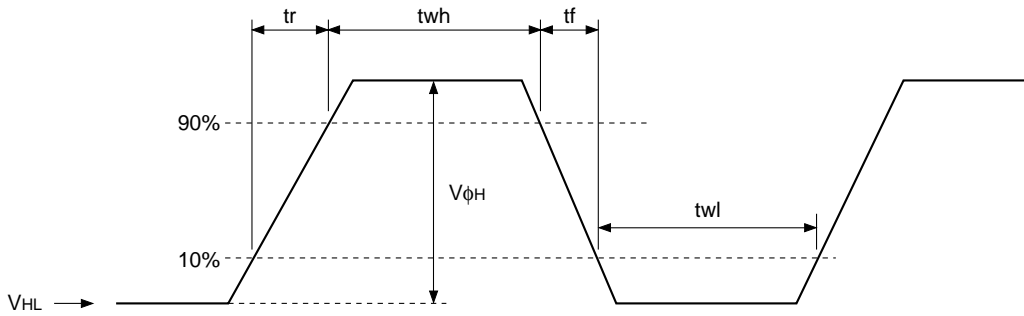

(4) Reset gate clock waveform

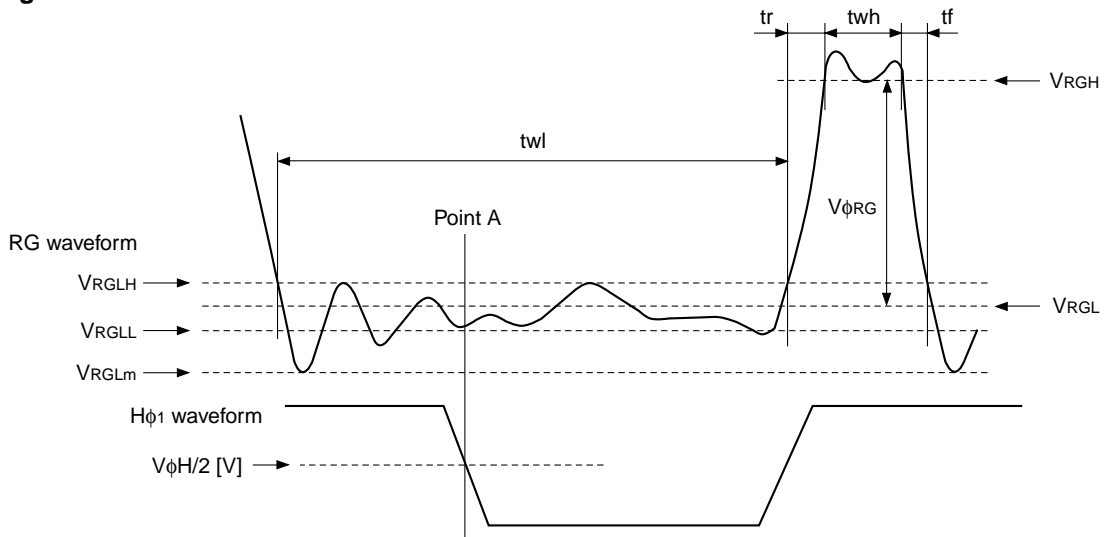

V_{RGLH} is the maximum value and V_{RGLL} is the minimum value of the coupling waveform during the period from Point A in the above diagram until the rising edge of RG. In addition, V_{RGL} is the average value of V_{RGLH} and V_{RGLL} .

$$V_{RGL} = (V_{RGLH} + V_{RGLL})/2$$

Assuming V_{RGH} is the minimum value during the interval t_{wh} , then:

$$V_{\phi RG} = V_{RGH} - V_{RGL}$$

Negative overshoot level during the falling edge of RG is V_{RGLm} .

(5) Substrate clock waveform

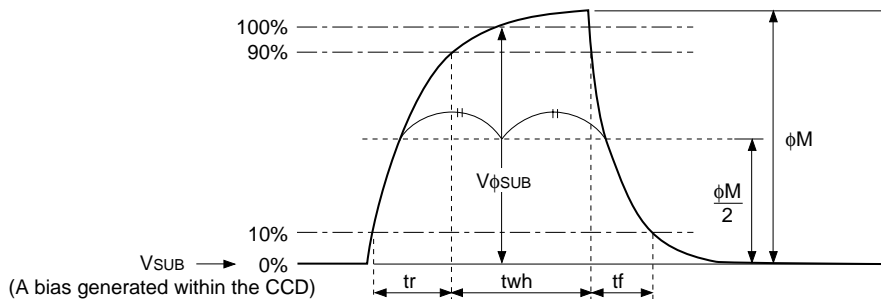

Clock Switching Characteristics

| Item | Symbol | twh | | | twl | | | tr | | | tf | | | Unit | Remarks | |
|---------------------------|--|--------------|------|------|------|------|------|------|------|------|------|------|------|---------|---------------------|----|
| | | Min. | Typ. | Max. | Min. | Typ. | Max. | Min. | Typ. | Max. | Min. | Typ. | Max. | | | |
| Readout clock | V_T | 2.3 | 2.5 | | | | | | 0.5 | | | 0.5 | | μ s | During readout | |
| Vertical transfer clock | $V_{\phi 1}, V_{\phi 2}, V_{\phi 3}, V_{\phi 4}$ | | | | | | | | | | 15 | | 250 | ns | *1 | |
| Horizontal transfer clock | During imaging | $H_{\phi 1}$ | 26 | 28.5 | | 26 | 28.5 | | | 6.5 | 9.5 | | 6.5 | 9.5 | ns | *2 |
| | | $H_{\phi 2}$ | 26 | 28.5 | | 26 | 28.5 | | | 6.5 | 9.5 | | 6.5 | 9.5 | | |
| | During parallel-serial conversion | $H_{\phi 1}$ | | 5.38 | | | | | | 0.01 | | | 0.01 | | μ s | |
| | | $H_{\phi 2}$ | | | | | 5.38 | | | 0.01 | | | 0.01 | | | |
| Reset gate clock | ϕ_{RG} | 11 | 13 | | | 51 | | | 3 | | | 3 | | ns | | |
| Substrate clock | ϕ_{SUB} | 1.5 | 1.8 | | | | | | | 0.5 | | | 0.5 | μ s | During drain charge | |

*1 When vertical transfer clock driver CXD1267AN is used.

*2 When $V_{\phi H} = 3.0V$. $t_f \geq t_r - 2ns$, and the cross-point voltage (V_{CR}) for the $H_{\phi 1}$ rising side of the $H_{\phi 1}$ and $H_{\phi 2}$ waveforms must be at least $V_{\phi H}/2$ [V].

| Item | Symbol | two | | | Unit | Remarks |
|---------------------------|--------------------------|------|------|------|------|---------|
| | | Min. | Typ. | Max. | | |
| Horizontal transfer clock | $H_{\phi 1}, H_{\phi 2}$ | 22 | 26 | | ns | *3 |

*3 The overlap period for twh and twl of horizontal transfer clocks $H_{\phi 1}$ and $H_{\phi 2}$ is two.

Image Sensor Characteristics

(Ta = 25°C)

| Item | Symbol | Min. | Typ. | Max. | Unit | Measurement method | Remarks |
|--|-------------------|------|------|------|------|--------------------|---------------|
| Sensitivity | S | 350 | 440 | | mV | 1 | |
| Sensitivity ratio | RMgG | 0.93 | | 1.35 | | 2 | |
| | R _{YeCy} | 1.15 | | 1.48 | | 2 | |
| Saturation signal | Ysat | 720 | | | mV | 3 | Ta = 60°C |
| Smear | Sm | | -100 | -90 | dB | 4 | |
| Video signal shading | SHy | | | 20 | % | 5 | Zone 0 and I |
| | | | | 25 | % | 5 | Zone 0 to II' |
| Uniformity between video signal channels | ΔSr | | | 10 | % | 6 | |
| | ΔSb | | | 10 | % | 6 | |
| Dark signal | Ydt | | | 2 | mV | 7 | Ta = 60°C |
| Dark signal shading | ΔYdt | | | 1 | mV | 8 | Ta = 60°C |
| Flicker Y | Fy | | | 2 | % | 9 | |
| Flicker R-Y | Fcr | | | 5 | % | 9 | |
| Flicker B-Y | Fcb | | | 5 | % | 9 | |
| Line crawl R | Lcr | | | 3 | % | 10 | |
| Line crawl G | Lcg | | | 3 | % | 10 | |
| Line crawl B | Lcb | | | 3 | % | 10 | |
| Line crawl W | Lcw | | | 3 | % | 10 | |
| Lag | Lag | | | 0.5 | % | 11 | |

Zone Definition of Video Signal Shading

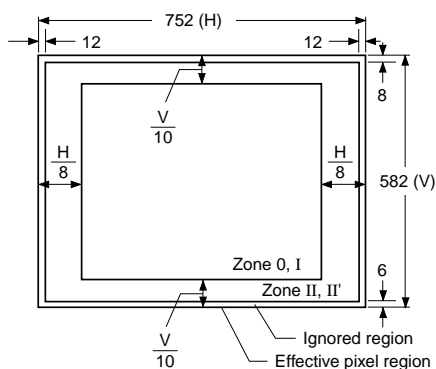

Measurement System

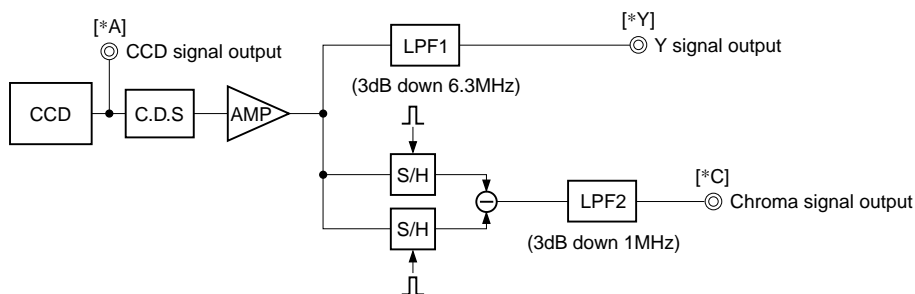

Note) Adjust the amplifier gain so that the gain between [*A] and [*Y], and between [*A] and [*C] equals 1.

Image Sensor Characteristics Measurement Method

◎ **Measurement conditions**

- 1) In the following measurements, the device drive conditions are at the typical values of the bias and clock voltage conditions.
- 2) In the following measurements, spot blemishes are excluded and, unless otherwise specified, the optical black level (OB) is used as the reference for the signal output, which is taken as the value of Y signal output or chroma signal output of the measurement system.

◎ **Color coding of this image sensor & Composition of luminance (Y) and chroma (color difference) signals**

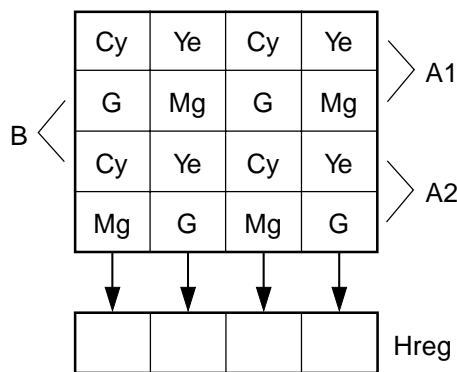

Color Coding Diagram

As shown in the left figure, fields are read out. The charge is mixed by pairs such as A1 and A2 in the A field. (pairs such as B in the B field)

As a result, the sequence of charges output as signals from the horizontal shift register (Hreg) is, for line A1, (G + Cy), (Mg + Ye), (G + Cy), and (Mg + Ye).

These signals are processed to form the Y signal and chroma (color difference) signal. The Y signal is formed by adding adjacent signals, and the chroma signal is formed by subtracting adjacent signals. In other words, the approximation:

$$Y = \{(G + Cy) + (Mg + Ye)\} \times 1/2$$

$$= 1/2 \{2B + 3G + 2R\}$$

is used for the Y signal, and the approximation:

$$R - Y = \{(Mg + Ye) - (G + Cy)\}$$

$$= \{2R - G\}$$

is used for the chroma (color difference) signal. For line A2, the signals output from Hreg in sequence are (Mg + Cy), (G + Ye), (Mg + Cy), (G + Ye).

The Y signal is formed from these signals as follows:

$$Y = \{(G + Ye) + (Mg + Cy)\} \times 1/2$$

$$= 1/2 \{2B + 3G + 2R\}$$

This is balanced since it is formed in the same way as for line A1.

In a like manner, the chroma (color difference) signal is approximated as follows:

$$-(B - Y) = \{(G + Ye) - (Mg + Cy)\}$$

$$= -\{2B - G\}$$

In other words, the chroma signal can be retrieved according to the sequence of lines from R - Y and -(B - Y) in alternation. This is also true for the B field.

◎ Definition of standard imaging conditions

1) Standard imaging condition I:

Use a pattern box (luminance 706cd/m², color temperature of 3200K halogen source) as a subject. (Pattern for evaluation is not applicable.) Use a testing standard lens with CM500S (t = 1.0mm) as an IR cut filter and image at F5.6. The luminous intensity to the sensor receiving surface at this point is defined as the standard sensitivity testing luminous intensity.

2) Standard imaging condition II:

Image a light source (color temperature of 3200K) with a uniformity of brightness within 2% at all angles. Use a testing standard lens with CM500S (t = 1.0mm) as an IR cut filter. The luminous intensity is adjusted to the value indicated in each testing item by the lens diaphragm.

3) Standard imaging condition III:

Image a light source (color temperature of 3200K) with a uniformity of brightness within 2% at all angles. Use a testing standard lens (exit pupil distance –33mm) with CM500S (t = 1.0mm) as an IR cut filter. The luminous intensity is adjusted to the value indicated in each testing item by the lens diaphragm.

1. Sensitivity

Set to standard imaging condition I. After selecting the electronic shutter mode with a shutter speed of 1/250s, measure the Y signal (Y_s) at the center of the screen and substitute the value into the following formula.

$$S = Y_s \times \frac{250}{50} \text{ [mV]}$$

2. Sensitivity ratio

Set to standard imaging condition II. Adjust the luminous intensity so that the average value of the Y signal output is 200mV, and then measure the Mg signal output (S_{Mg} [mV]) and G signal output (S_G [mV]), and Ye signal output (S_{Ye} [mV]) and Cy signal output (S_{Cy} [mV]) at the center of the screen with frame readout method. Substitute the values into the following formula.

$$R_{MgG} = S_{Mg}/S_G$$

$$R_{YeCy} = S_{Ye}/S_{Cy}$$

3. Saturation signal

Set to standard imaging condition II. After adjusting the luminous intensity to 10 times the intensity with average value of the Y signal output, 200mV, measure the minimum value of the Y signal.

4. Smear

Set to standard imaging condition II. With the lens diaphragm at F5.6 to F8, adjust the luminous intensity to 500 times the intensity with average value of the Y signal output, 200mV. When the readout clock is stopped and the charge drain is executed by the electronic shutter at the respective H blankings, measure the maximum value (Y_{Sm} [mV]) of the Y signal output and substitute the value into the following formula.

$$S_m = 20 \times \log \left(\frac{Y_{Sm}}{200} \times \frac{1}{500} \times \frac{1}{10} \right) \text{ [dB]} \text{ (1/10V method conversion value)}$$

5. Video signal shading

Set to standard imaging condition III. With the lens diaphragm at F5.6 to F8, adjust the luminous intensity so that the average value of the Y signal output is 200mV. Then measure the maximum (Ymax [mV]) and minimum (Ymin [mV]) values of the Y signal and substitute the values into the following formula.

$$SH_y = (Y_{\max} - Y_{\min})/200 \times 100 [\%]$$

6. Uniformity between video signal channels

Set to standard imaging condition II. Adjust the luminous intensity so that the average value of the Y signal output is 200mV, and then measure the maximum (Crmax, Cbmax [mV]) and minimum (Crmin, Cbmin [mV]) values of the R – Y and B – Y channels of the chroma signal and substitute the values into the following formula.

$$\Delta Sr = | (Cr_{\max} - Cr_{\min})/200 | \times 100 [\%]$$

$$\Delta Sb = | (Cb_{\max} - Cb_{\min})/200 | \times 100 [\%]$$

7. Dark signal

Measure the average value of the Y signal output (Ydt [mV]) with the device ambient temperature 60°C and the device in the light-obstructed state, using the horizontal idle transfer level as a reference.

8. Dark signal shading

After measuring 7, measure the maximum (Ydmax [mV]) and minimum (Ydmin [mV]) values of the Y signal output and substitute the values into the following formula.

$$\Delta Y_{dt} = Y_{d\max} - Y_{d\min} [\text{mV}]$$

9. Flicker

1) Fy

Set to standard imaging condition II. Adjust the luminous intensity so that the average value of the Y signal output is 200mV, and then measure the difference in the signal level between fields (ΔY_f [mV]). Then substitute the value into the following formula.

$$F_y = (\Delta Y_f/200) \times 100 [\%]$$

2) Fcr, Fcb

Set to standard imaging condition II. Adjust the luminous intensity so that the average value of the Y signal output is 200mV, insert an R or B filter, and then measure both the difference in the signal level between fields of the chroma signal (ΔC_r , ΔC_b) as well as the average value of the chroma signal output (CAr, CAb). Substitute the values into the following formula.

$$F_{ci} = (\Delta C_i/CA_i) \times 100 [\%] \quad (i = r, b)$$

10. Line crawls

Set to standard imaging condition II. Adjust the luminous intensity so that the average value of the Y signal output is 200mV, and then insert a white subject and R, G, and B filters and measure the difference between Y signal lines for the same field (ΔY_{lw} , ΔY_{lr} , ΔY_{lg} , ΔY_{lb} [mV]). Substitute the values into the following formula.

$$L_{ci} = (\Delta Y_{li}/200) \times 100 [\%] \quad (i = w, r, g, b)$$

11. Lag

Adjust the Y signal output value generated by strobe light to 200mV. After setting the strobe light so that it strobes with the following timing, measure the residual signal (Ylag). Substitute the value into the following formula.

$$Lag = (Y_{lag}/200) \times 100 [\%]$$

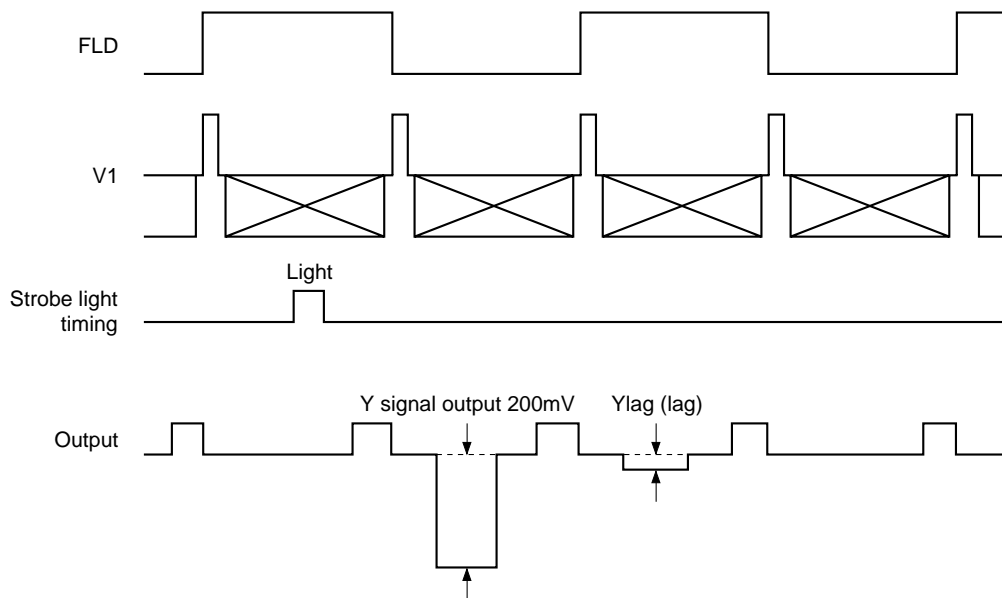

Drive Circuit

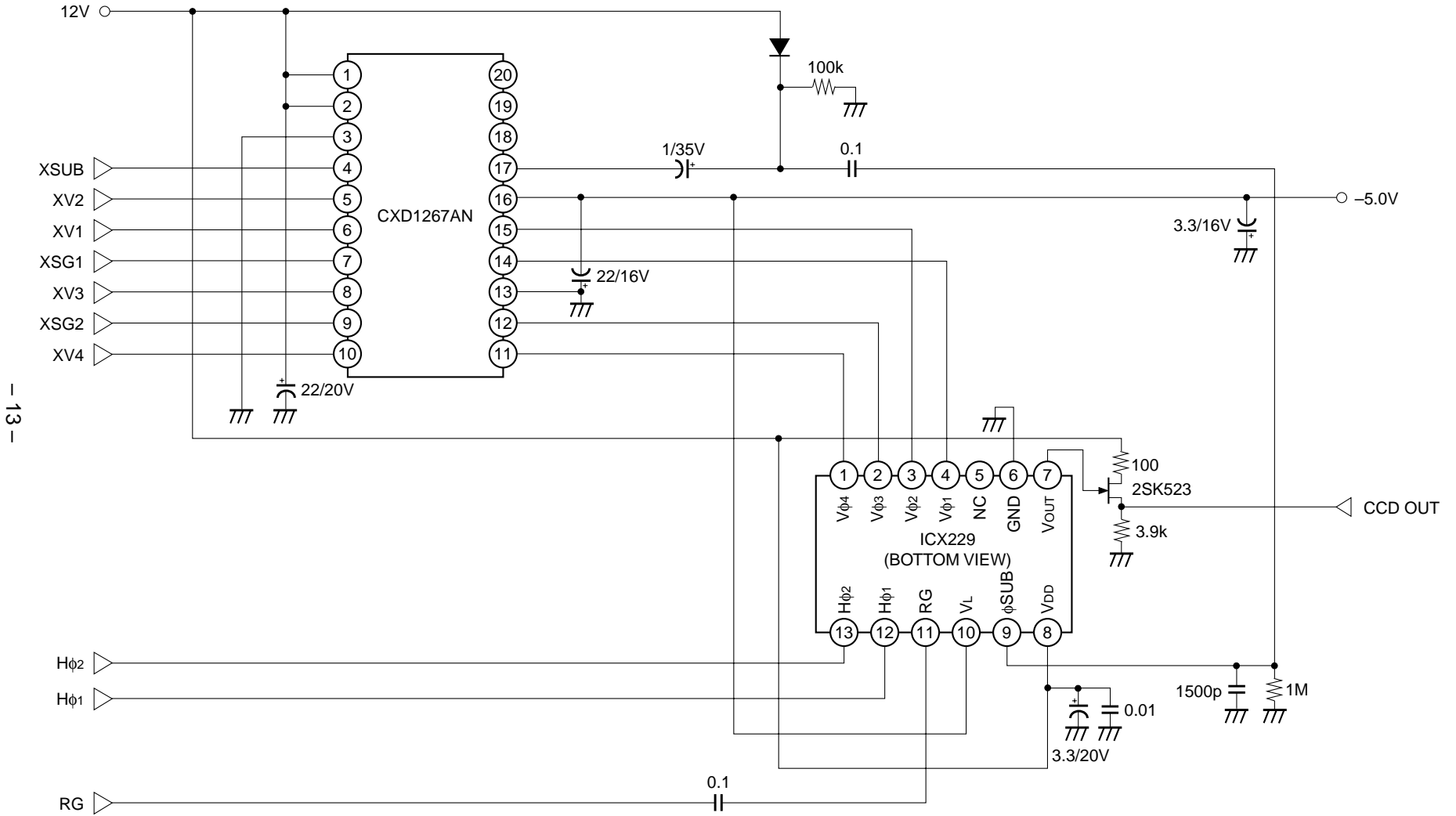

Spectral Sensitivity Characteristics (excludes both lens characteristics and light source characteristics)

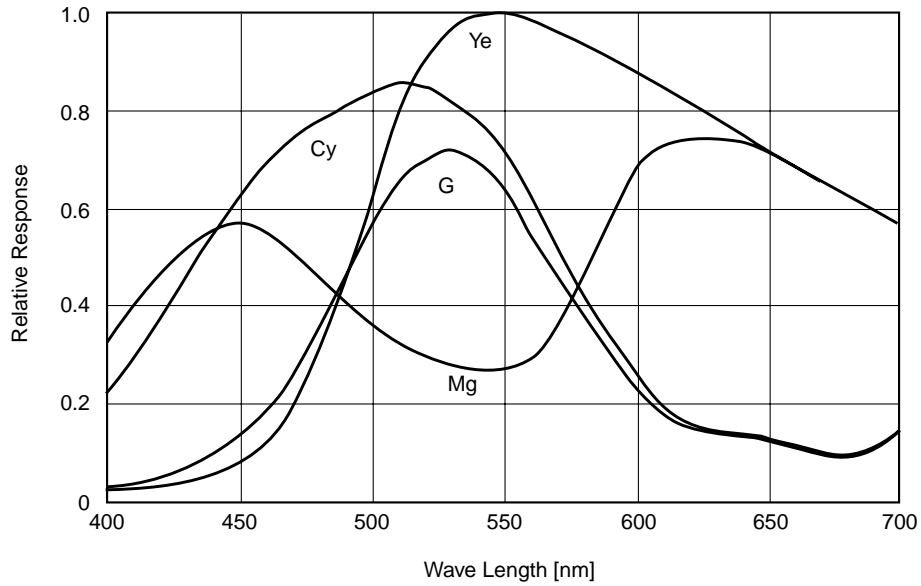

Sensor Readout Clock Timing Chart

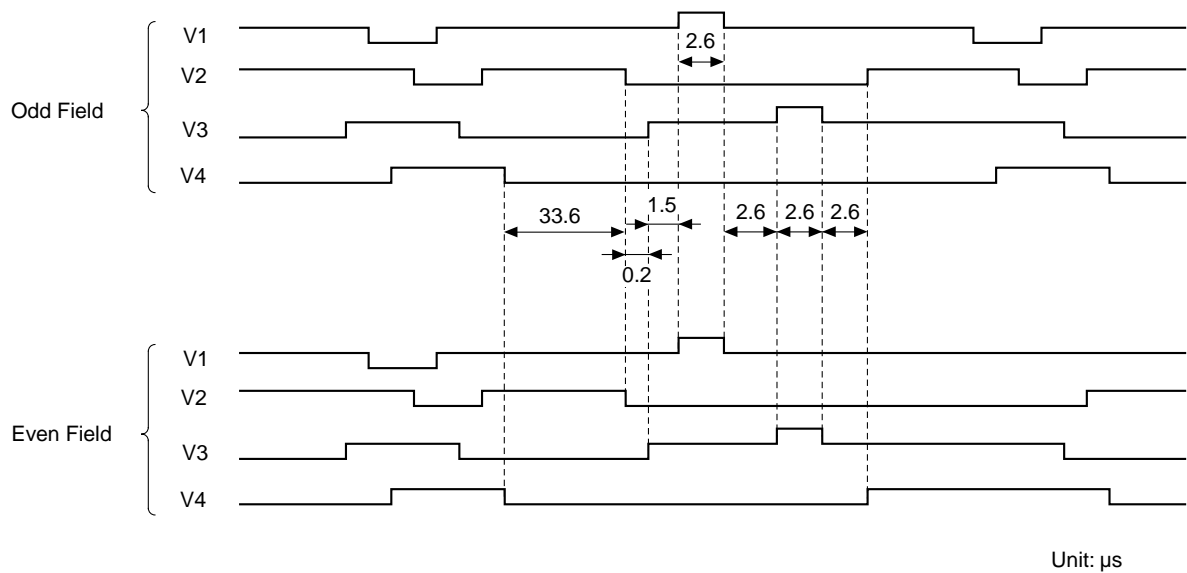

Drive Timing Chart (Vertical Sync)

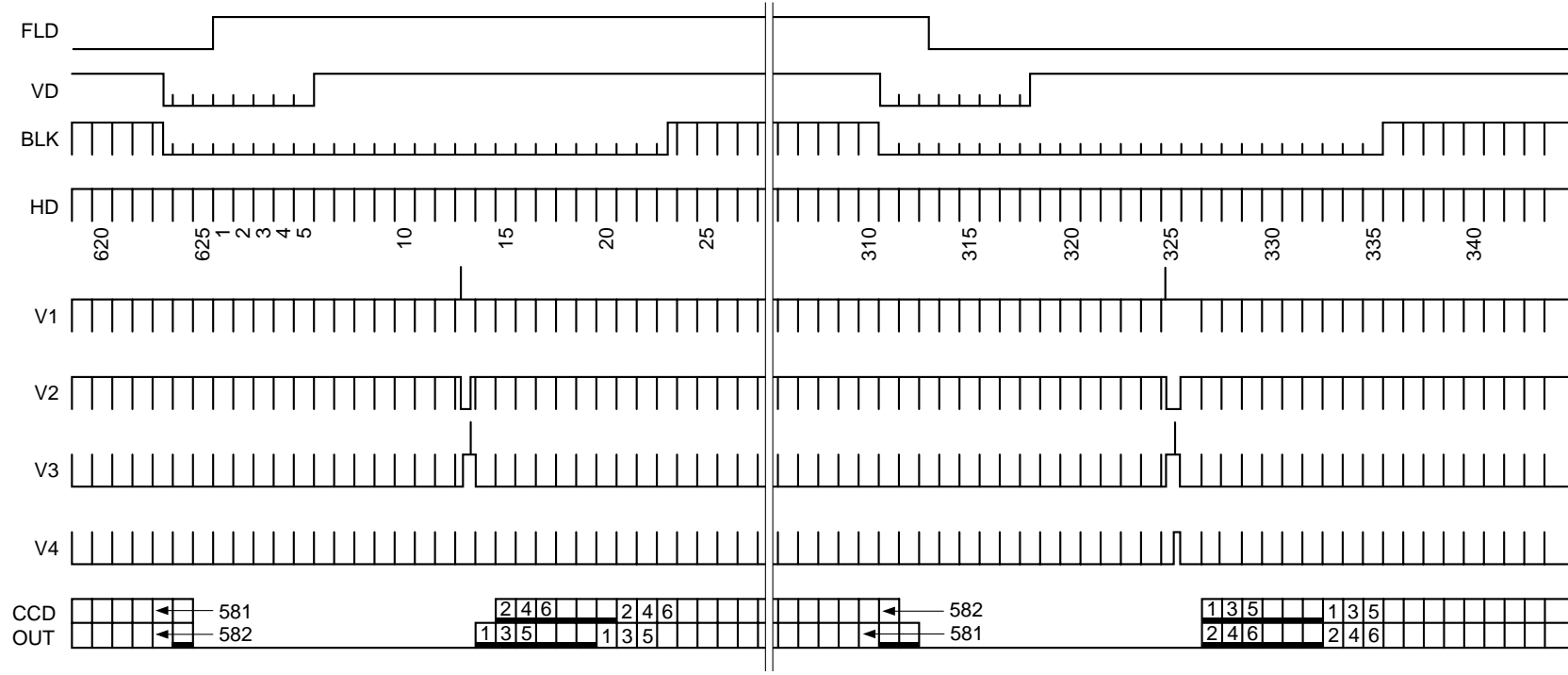

Drive Timing Chart (Horizontal Sync)

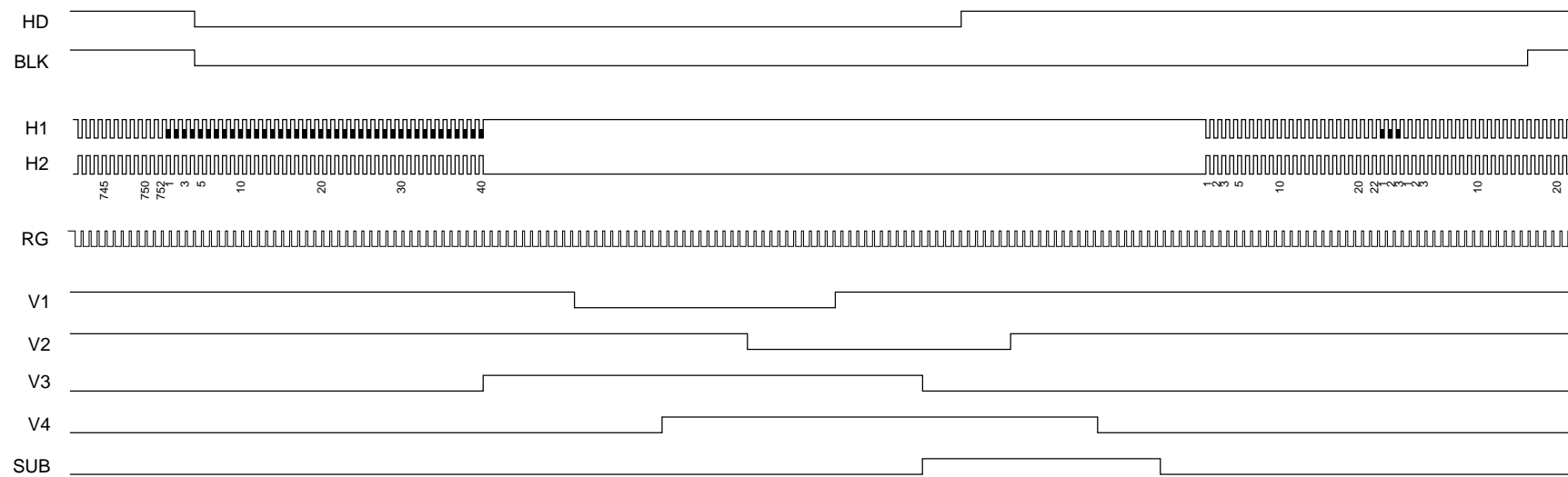

Notes on Handling

- 1) Static charge prevention
CCD image sensors are easily damaged by static discharge. Before handling be sure to take the following protective measures.
 - a) Either handle bare handed or use non-chargeable gloves, clothes or material.
Also use conductive shoes.
 - b) When handling directly use an earth band.
 - c) Install a conductive mat on the floor or working table to prevent the generation of static electricity.
 - d) Ionized air is recommended for discharge when handling CCD image sensor.
 - e) For the shipment of mounted substrates, use boxes treated for the prevention of static charges.
- 2) Soldering
 - a) Make sure the package temperature does not exceed 80°C.
 - b) Solder dipping in a mounting furnace causes damage to the glass and other defects. Use a 30W soldering iron with a ground wire and solder each pin in less than 2 seconds. For repairs and remount, cool sufficiently.
 - c) To dismount an image sensor, do not use a solder suction equipment. When using an electric desoldering tool, use a thermal controller of the zero cross On/Off type and connect it to ground.
- 3) Dust and dirt protection
Image sensors are packed and delivered by taking care of protecting its glass plates from harmful dust and dirt. Clean glass plates with the following operation as required, and use them.
 - a) Operate in clean environments (around class 1000 is appropriate).
 - b) Do not either touch glass plates by hand or have any object come in contact with glass surfaces. Should dirt stick to a glass surface, blow it off with an air blower. (For dirt stuck through static electricity ionized air is recommended.)
 - c) Clean with a cotton bud and ethyl alcohol if the grease stained. Be careful not to scratch the glass.
 - d) Keep in a case to protect from dust and dirt. To prevent dew condensation, preheat or precool when moving to a room with great temperature differences.
 - e) When a protective tape is applied before shipping, just before use remove the tape applied for electrostatic protection. Do not reuse the tape.
- 4) Do not expose to strong light (sun rays) for long periods, color filters will be discolored. When high luminance objects are imaged with the exposure level control by electronic-iris, the luminance of the image-plane may become excessive and discolor of the color filter will possibly be accelerated. In such a case, it is advisable that taking-lens with the automatic-iris and closing of the shutter during the power-off mode should be properly arranged. For continuous using under cruel condition exceeding the normal using condition, consult our company.
- 5) Exposure to high temperature or humidity will affect the characteristics. Accordingly avoid storage or usage in such conditions.
- 6) CCD image sensors are precise optical equipment that should not be subject to too much mechanical shocks.
- 7) Eclipse (to get dark around the four corners of the picture) may occur when some object lenses are in the

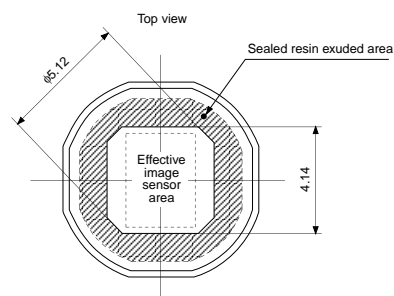

Package Outline

Unit: mm

13 pin PCA

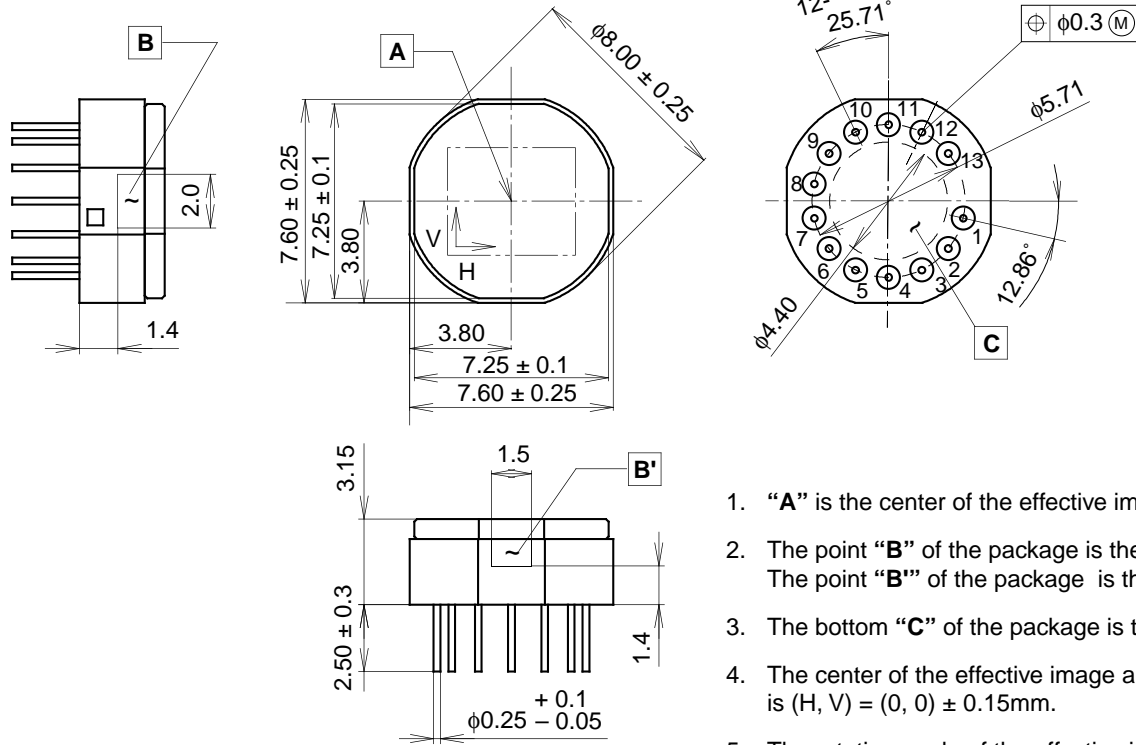

1. "A" is the center of the effective image area.
2. The point "B" of the package is the horizontal reference. The point "B'" of the package is the vertical reference.
3. The bottom "C" of the package is the height reference.
4. The center of the effective image area relative to the center of the package (*) is (H, V) = (0, 0) \pm 0.15mm.
5. The rotation angle of the effective image area relative to H and V is $\pm 1^\circ$.
6. The height from the bottom "C" to the effective image area is 1.44 ± 0.15 mm.
7. The tilt of the effective image area relative to the bottom "C" is less than 60 μ m.
8. The thickness of the cover glass is 0.75mm, and the refractive index is 1.5.

* Center of the package: The center is halfway between two pairs of opposite sides, as measured from "B", "B'".

PACKAGE STRUCTURE

| | |
|------------------|----------------|
| PACKAGE MATERIAL | Ceramic |
| LEAD TREATMENT | GOLD PLATING |
| LEAD MATERIAL | Fe-Ni-Co Alloy |
| PACKAGE MASS | 0.40g |
| DRAWING NUMBER | AS-D2-01(E) |