

Powerex, Inc., Hillis Street, Youngwood, Pennsylvania 15697 (412) 925-7272
 Powerex, Europe, S.A. 428 Avenue G. Durand, BP107, 72003 Le Mans, France (43) 41.14.14

Dual IGBTMOD™ Power Module

50 Amperes/600 Volts

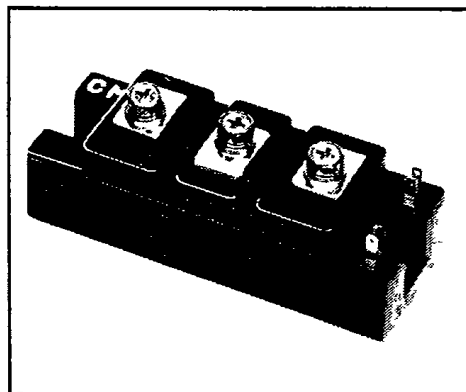
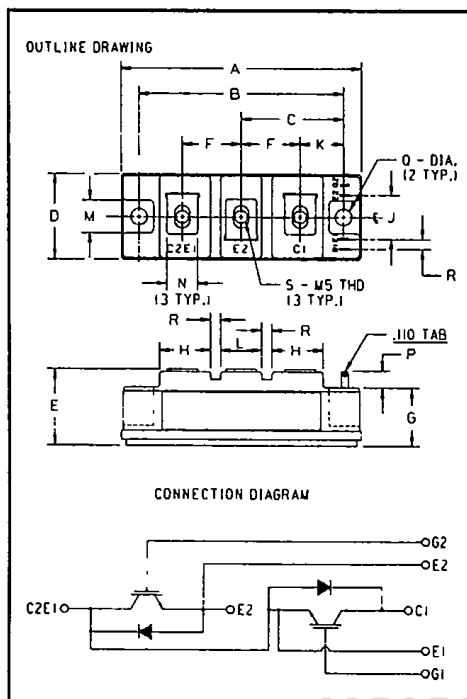

ID226005
Dual IGBTMOD™ Power Module
50 Amperes/600 Volts

ID226005 Outline Drawing

Dimension	Inches	Millimeters
A	3.70	94
B	3.150±.010	80±0.25
C	1.57	40
D	1.34	34
E	1.22Max.	31 Max.
F	.90	23
G	.85	21.5
H	.79	20
J	.71	18
K	.67	17
L	.63	16
M	.51	13
N	.47	12
P	.28	7
Q	.256 Dia.	Dia. 6.5
R	.16	4
S	M5 Metric	M5

Description

Powerex IGBTMOD™ Modules are designed for use in switching applications. Each module consists of two IGBT Transistors in a half-bridge configuration, with each transistor having a reverse-connected super-fast recovery free wheel diode. All components and interconnects are isolated from the heat sinking baseplate, offering simplified system assembly and thermal management.

Features:

- Low Drive Power
- Low $V_{CE(sat)}$
- Discrete Super-Fast Recovery (150ns) Free Wheel Diode
- High Frequency Operation (15-20kHz)
- Isolated Base Plate for Easy Heat Sinking

Applications:

- AC Motor Control
- Motion/Servo Control
- UPS
- Welding Power Supplies
- Laser Power Supplies

Ordering Information

Example: Select the complete eight digit part module number you desire from the table below -i.e. ID226005 is a 600V (V_{CES}), 50 Ampere Dual IGBTMOD™ Power Module.

Type	V_{CES} Volts (x10)	Current Rating Amperes (x10)
ID22	60	05

Powerex, Inc., Hillis Street, Youngwood, Pennsylvania 15697 (412) 925-7272

Powerex, Europe, S.A. 428 Avenue G. Durand, BP107, 72003 Le Mans, France (43) 41.14.14

ID226005

Dual IGBTMOD™ Power Module

50 Amperes/600Volts

Absolute Maximum Ratings, $T_j = 25^\circ\text{C}$ unless otherwise specified

Rating	Symbol	ID226005	Units
Junction Temperature	T_j	-40 to 150	$^\circ\text{C}$
Storage Temperature	T_{stg}	-40 to 125	$^\circ\text{C}$
Collector-Emitter Voltage (G-E SHORT)	V_{CES}	600	Volts
Gate-Emitter Voltage	V_{GES}	± 20	Volts
Collector Current	I_c	50	Amperes
Peak Collector Current	I_{CM}	100*	Amperes
Diode Forward Current	I_{FM}	50	Amperes
Diode Forward Surge Current	I_{FM}	100*	Amperes
Power Dissipation	P_d	250	Watts
Max. Mounting Torque M5 Terminal Screws	—	17	in.-lb.
Max. Mounting Torque M6 Mounting Screws	—	26	in.-lb.
Module Weight (Typical)	—	190	Grams
V isolation	V_{RMS}	2500	Volts

* Pulse width and repetition rate should be such that device junction temperature does not exceed the device rating.

Static Electrical Characteristics, $T_j = 25^\circ\text{C}$ unless otherwise specified

Characteristics	Symbol	Test Conditions	Min.	Typ.	Max.	Units
Collector-Cutoff Current	I_{CES}	$V_{\text{CE}}=V_{\text{CES}}, V_{\text{GE}}=0\text{V}$	—	—	1.0	mA
Gate Leakage Current	I_{GES}	$V_{\text{GE}}=V_{\text{GES}}, V_{\text{CE}}=0\text{V}$	—	—	0.5	μA
Gate-Emitter Threshold Voltage	$V_{\text{GE(th)}}$	$I_c=5\text{mA}, V_{\text{CE}}=10\text{V}$	3.0	4.0	6.0	Volts
Collector-Emitter Saturation Voltage	$V_{\text{CE(sat)}}$	$I_c=50\text{A}, V_{\text{GE}}=15\text{V}$	—	3.0	5.0**	Volts
		$I_c=50\text{A}, V_{\text{GE}}=15\text{V}, T_j=150^\circ\text{C}$	—	3.2	**	Volts
Total Gate Charge	Q_g	$V_{\text{CC}}=300\text{V}, I_c=50\text{A}, V_{\text{GS}}=15\text{V}$	—	160	—	nC
Diode Forward Voltage	V_{FM}	$I_c=-50\text{A}, V_{\text{GS}}=0\text{V}$	—	—	2.5	Volts

** Pulse width and repetition rate should be such that device junction temperature rise is negligible.

Dynamic Electrical Characteristics, $T_j = 25^\circ\text{C}$ unless otherwise specified

Characteristics	Symbol	Test Conditions	Min.	Typ.	Max.	Units
Input Capacitance	C_{ies}		—	—	5000	pF
Output Capacitance	C_{oes}	$V_{\text{GE}}=0\text{V}, V_{\text{CE}}=10\text{V}, f=1\text{MHz}$	—	—	1200	pF
Reverse Transfer Capacitance	C_{res}		—	—	120	pF
Resistive Load	Turn-on Delay Time	$V_{\text{CC}}=300\text{V}, I_c=50\text{A},$ $V_{\text{GE1}}=V_{\text{GE2}}=15\text{V}, R_g=50\Omega$	—	—	250	ns
	Rise Time					
Switch Times	Turn-off Delay Time	$V_{\text{GE1}}=V_{\text{GE2}}=15\text{V}, R_g=50\Omega$	—	—	600	ns
	Fall Time					
Diode Reverse Recovery Time	t_{rr}	$I_E=50\text{A}, di_E/dt=-100\text{A}/\mu\text{s}$	—	—	200	ns
Diode Reverse Recovery Charge	Q_{rr}	$I_E=50\text{A}, di_E/dt=-100\text{A}/\mu\text{s}$	—	0.6	—	μC

Thermal and Mechanical Characteristics, $T_j = 25^\circ\text{C}$ unless otherwise specified

Characteristics	Symbol	Test Conditions	Min.	Typ.	Max.	Units
Thermal Resistance, Junction to Case	$R_{\text{th(j-c)}}$	Per IGBT	—	—	0.50	$^\circ\text{C}/\text{W}$
Thermal Resistance, Junction to Case	$R_{\text{th(j-c)}}$	Per Free Wheel Diode	—	—	1.00	$^\circ\text{C}/\text{W}$
Contact Thermal Resistance	$R_{\text{th(c-l)}}$	Per Half Module	—	—	0.15	$^\circ\text{C}/\text{W}$

OUTPUT CHARACTERISTICS (TYPICAL)

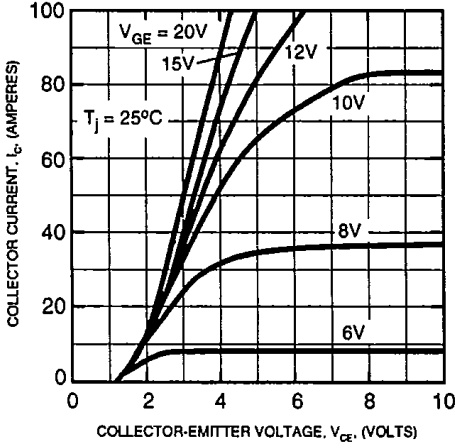

TRANSFER CHARACTERISTICS (TYPICAL)

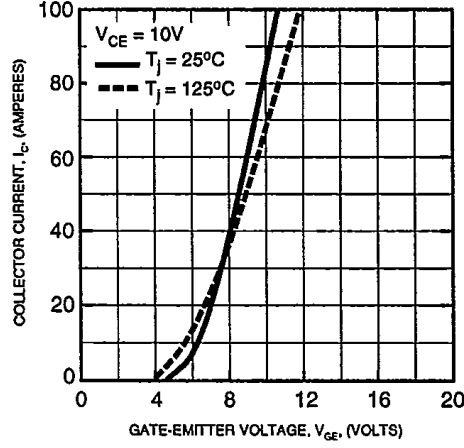

COLLECTOR-EMITTER SATURATION VOLTAGE CHARACTERISTICS (TYPICAL)

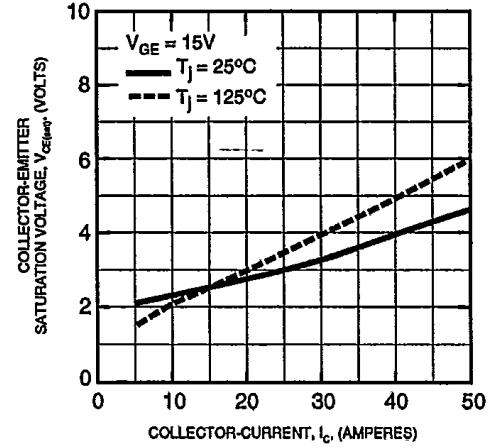

COLLECTOR-EMITTER SATURATION VOLTAGE CHARACTERISTICS (TYPICAL)

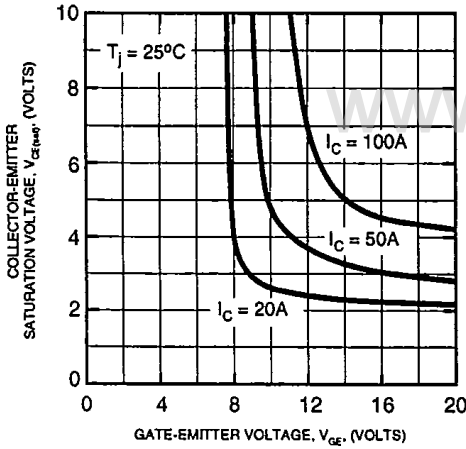

FREE-WHEEL DIODE FORWARD CHARACTERISTICS (TYPICAL)

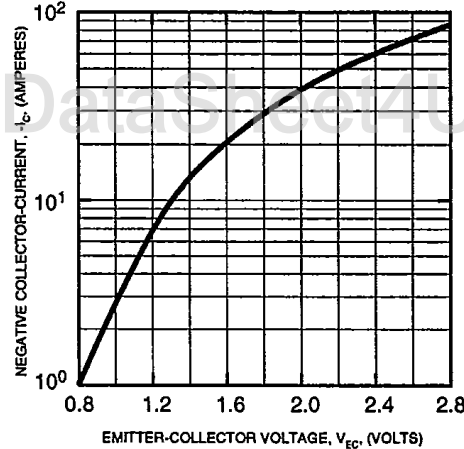

CAPACITANCE VS. V_{ce} (TYPICAL)

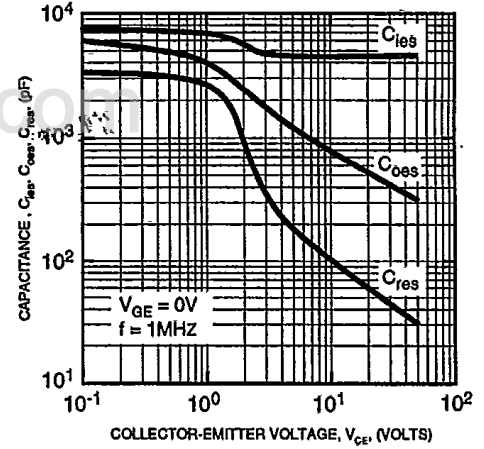

HALF-BRIDGE SWITCHING CHARACTERISTICS (TYPICAL)

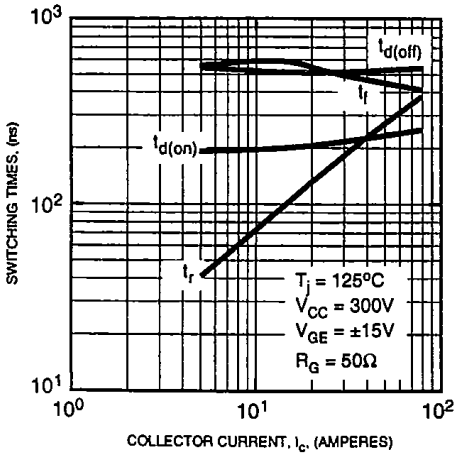

REVERSE RECOVERY CHARACTERISTICS (TYPICAL)

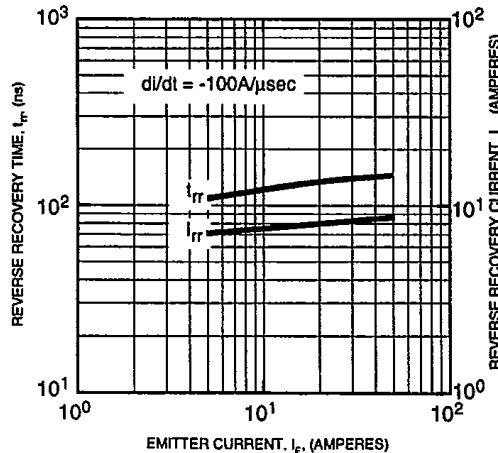

GATE CHARGE, V_{ge}

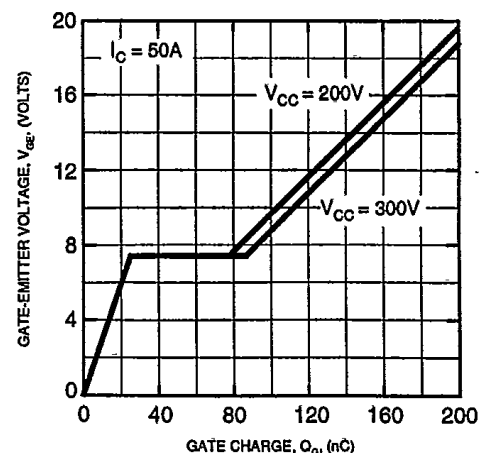

ID226005
Dual IGBTMOD™ Power Module
50 Amperes/600Volts

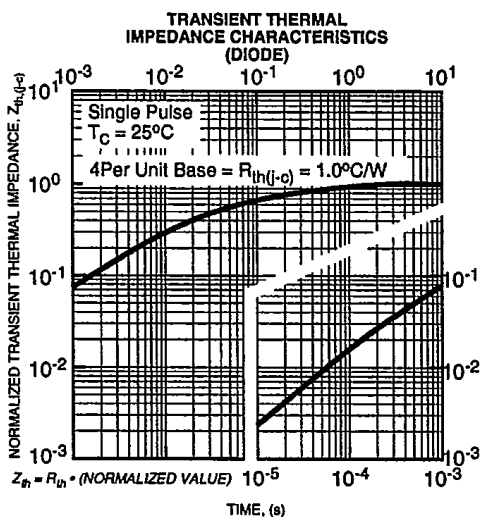
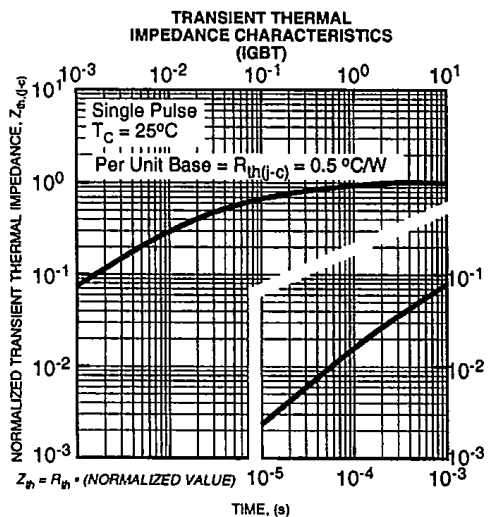

SWITCHING TIME TEST CIRCUITS & WAVEFORMS

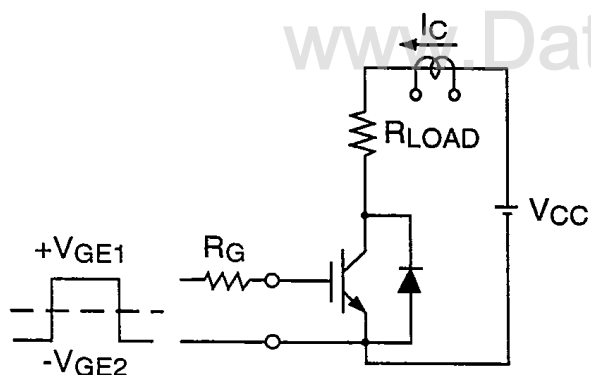

Resistance Load Switching Test Circuit

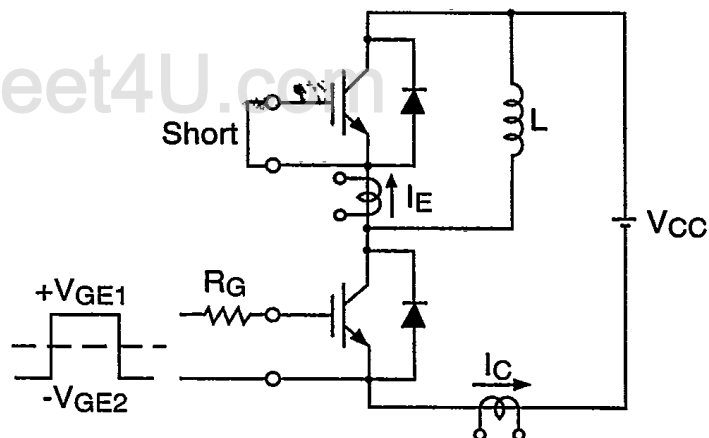

Half-Bridge Switching Test Circuit

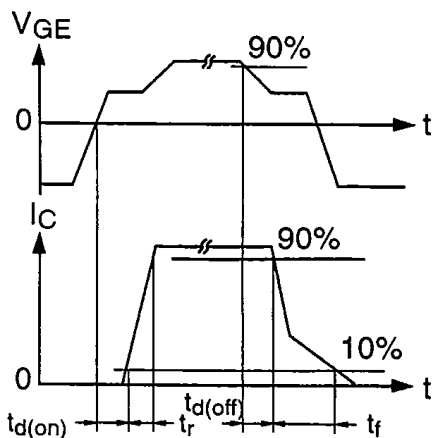

Switching Time Test Waveforms

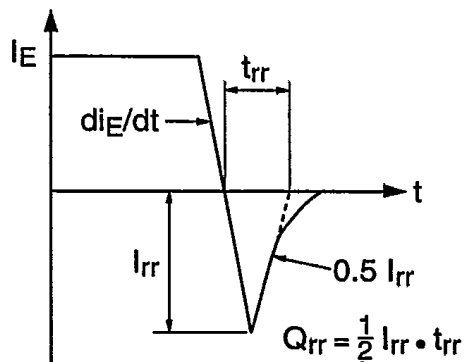

t_{rr} , Q_{rr} Waveforms