

Powerex, Inc., Hillis Street, Youngwood, Pennsylvania 15697 (412) 925-7272
 Powerex, Europe, S.A. 428 Avenue G. Durand, BP107, 72003 Le Mans, France (43) 41.14.14

**Dual IGBTMOD™
 Power Module**

100 Amperes/600 Volts

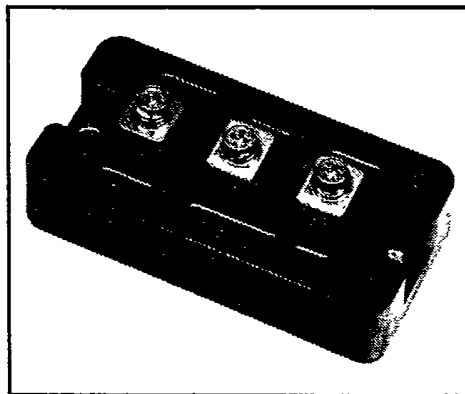
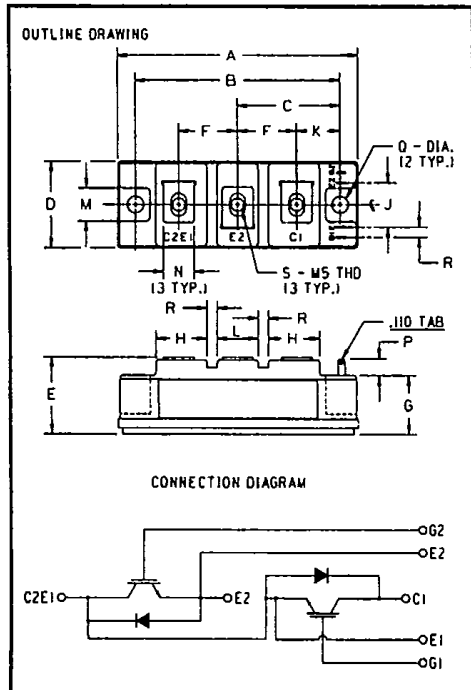

**ID226010
 Dual IGBTMOD™ Power Module
 100 Amperes/600 Volts**

**ID226010
 Outline Drawing**

Dimension	Inches	Millimeters
A	3.70	94
B	3.150±.010	80±0.25
C	1.57	40
D	1.34	34
E	1.22Max.	31 Max.
F	.90	23
G	.85	21.5
H	.79	20
J	.71	18
K	.67	17
L	.63	16
M	.51	13
N	.47	12
P	.28	7
Q	.256 Dia.	Dia. 6.5
R	.16	4
S	M5 Metric	M5

Description

Powerex IGBTMOD™ Modules are designed for use in switching applications. Each module consists of two IGBT Transistors in a half-bridge configuration, with each transistor having a reverse-connected super-fast recovery free wheel diode. All components and interconnects are isolated from the heat sinking baseplate, offering simplified system assembly and thermal management.

Features:

- Low Drive Power
- Low $V_{CE(sat)}$
- Discrete Super-Fast Recovery (150ns) Free Wheel Diode
- High Frequency Operation (15-20kHz)
- Isolated Base Plate for Easy Heat Sinking

Applications:

- AC Motor Control
- Motion/Servo Control
- UPS
- Welding Power Supplies
- Laser Power Supplies

Ordering Information

Example: Select the complete eight digit part module number you desire from the table below -i.e., ID226010 is a 600V (V_{CES}), 100 Ampere Dual IGBTMOD™ Power Module.

Type	V_{CES} Volts (x10)	Current Rating Amperes (x10)
ID22	60	10

ID226010
Dual IGBTMOD™ Power Module
 100 Amperes/600Volts

Absolute Maximum Ratings, $T_j = 25^\circ\text{C}$ unless otherwise specified

Ratings	Symbol	ID226010	Units
Junction Temperature	T_j	-40 to 150	$^\circ\text{C}$
Storage Temperature	T_{stg}	-40 to 125	$^\circ\text{C}$
Collector-Emitter Voltage (G-E SHORT)	V_{CES}	600	Volts
Gate-Emitter Voltage	V_{GES}	± 20	Volts
Collector Current	I_C	100	Amperes
Peak Collector Current	I_{CM}	200*	Amperes
Diode Forward Current	I_{FM}	100	Amperes
Diode Forward Surge Current	I_{FM}	200*	Amperes
Power Dissipation	P_d	400	Watts
Max. Mounting Torque M5 Terminal Screws	—	17	in.-lb.
Max. Mounting Torque M6 Mounting Screws	—	26	in.-lb.
Module Weight (Typical)	—	190	Grams
V isolation	V_{RMS}	2500	Volts

* Pulse width and repetition rate should be such that device junction temperature does not exceed the device rating.

Static Electrical Characteristics, $T_j = 25^\circ\text{C}$ unless otherwise specified

Characteristics	Symbol	Test Conditions	Min.	Typ.	Max.	Units
Collector-Cutoff Current	I_{CES}	$V_{CE}=V_{CES}, V_{GE}=0V$	—	—	1.0	mA
Gate Leakage Current	I_{GES}	$V_{GE}=V_{GES}, V_{CE}=0V$	—	—	0.5	μA
Gate-Emitter Threshold Voltage	$V_{GE(th)}$	$I_C=10\text{mA}, V_{CE}=10V$	3.0	4.0	6.0	Volts
Collector-Emitter Saturation Voltage	$V_{CE(sat)}$	$I_C=100A, V_{GE}=15V$	—	3.0	5.0**	Volts
		$I_C=100A, V_{GE}=15V, T_j=150^\circ\text{C}$	—	3.2	**	Volts
Total Gate Charge	Q_G	$V_{CC}=300V, I_C=100A, V_{GS}=15V$	—	360	—	nC
Diode Forward Voltage	V_{FM}	$I_C=-100A, V_{GS}=0V$	—	—	2.5	Volts

** Pulse width and repetition rate should be such that device junction temperature rise is negligible.

Dynamic Electrical Characteristics, $T_j = 25^\circ\text{C}$ unless otherwise specified

Characteristics	Symbol	Test Conditions	Min.	Typ.	Max.	Units	
Input Capacitance	C_{ies}	$V_{GE}=0V, V_{CE}=10V, f=1\text{MHz}$	—	—	11000	pF	
Output Capacitance	C_{oes}		—	—	2700	pF	
Reverse Transfer Capacitance	C_{rea}		—	—	270	pF	
Resistive Load	Turn-on Delay Time	$V_{CC}=300V, I_C=100A, V_{GE1}=V_{GE2}=15V, R_G=25\Omega$	—	—	250	ns	
	Rise Time						800
	Turn-off Delay Time						
	Fall Time						800
Diode Reverse Recovery Time	t_{rr}	$I_E=100A, di_E/dt=-200A/\mu\text{s}$	—	—	200	ns	
Diode Reverse Recovery Charge	Q_{rr}	$I_E=100A, di_E/dt=200A/\mu\text{s}$	—	1.3	—	μC	

Thermal and Mechanical Characteristics, $T_j = 25^\circ\text{C}$ unless otherwise specified

Characteristics	Symbol	Test Conditions	Min.	Typ.	Max.	Units
Thermal Resistance, Junction to Case	$R_{th(j-c)}$	Per IGBT	—	—	0.31	$^\circ\text{C/W}$
Thermal Resistance, Junction to Case	$R_{th(j-c)}$	Per Free Wheel Diode	—	—	0.70	$^\circ\text{C/W}$
Contact Thermal Resistance	$R_{th(c-f)}$	Per Half Module	—	—	0.15	$^\circ\text{C/W}$

ID226010
 Dual IGBTMOD™ Power Module
 100 Amperes/600 Volts

OUTPUT CHARACTERISTICS (TYPICAL)

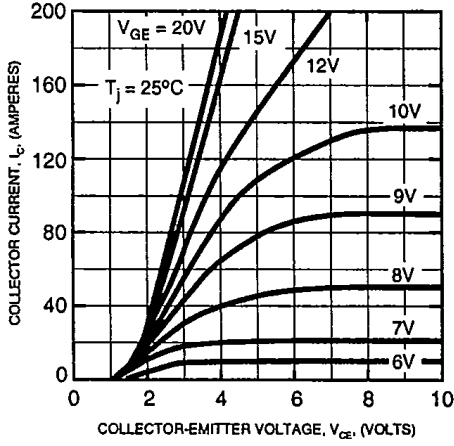

TRANSFER CHARACTERISTICS (TYPICAL)

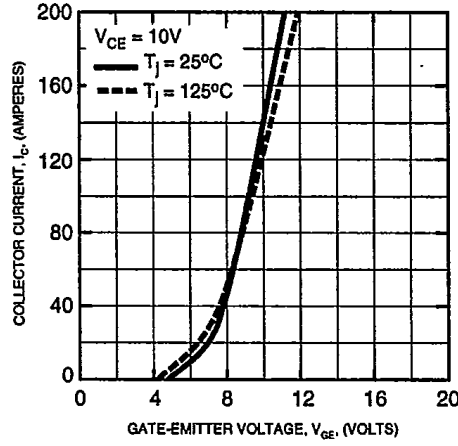

COLLECTOR-EMITTER SATURATION VOLTAGE CHARACTERISTICS (TYPICAL)

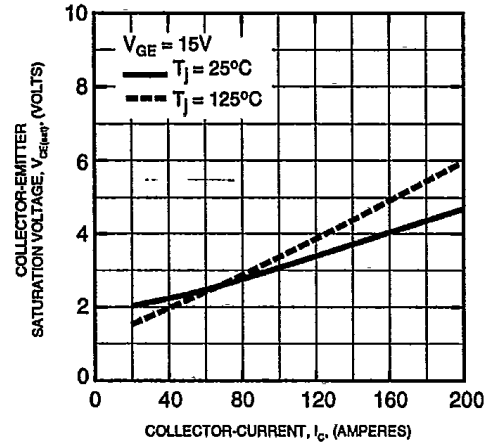

COLLECTOR-EMITTER SATURATION VOLTAGE CHARACTERISTICS (TYPICAL)

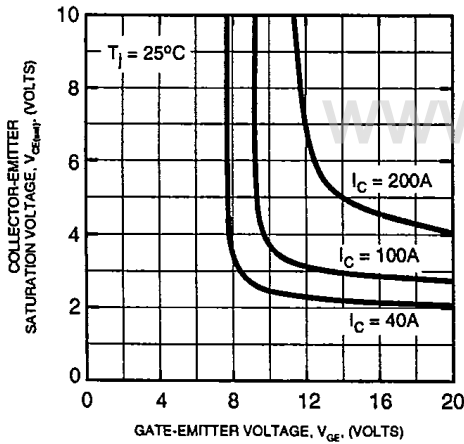

FREE-WHEEL DIODE FORWARD CHARACTERISTICS (TYPICAL)

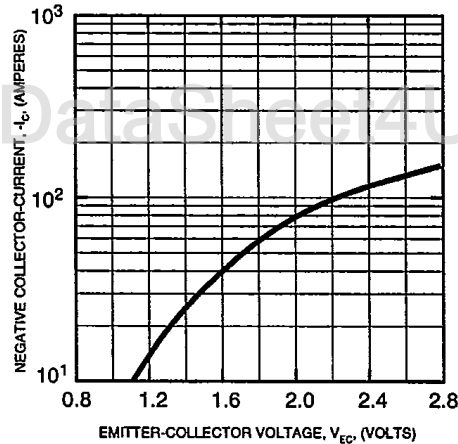

CAPACITANCE VS. V_{CE} (TYPICAL)

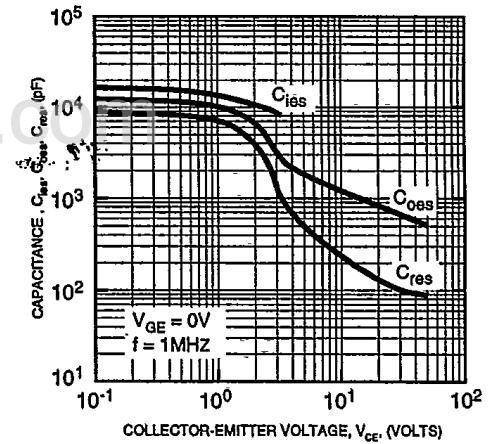

HALF-BRIDGE SWITCHING CHARACTERISTICS (TYPICAL)

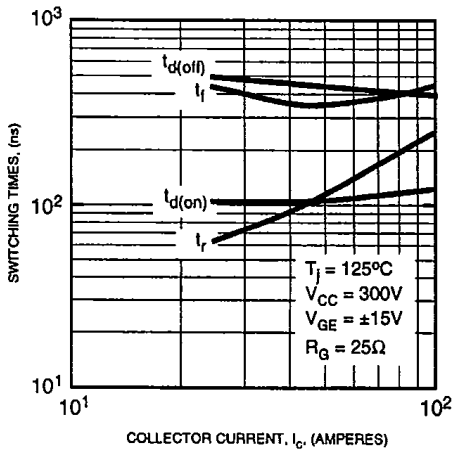

REVERSE RECOVERY CHARACTERISTICS (TYPICAL)

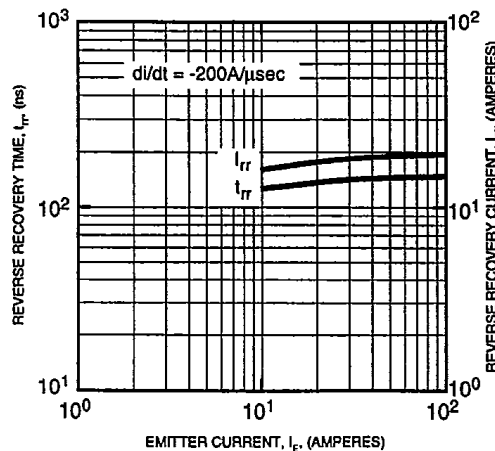

GATE CHARGE, V_{GE}

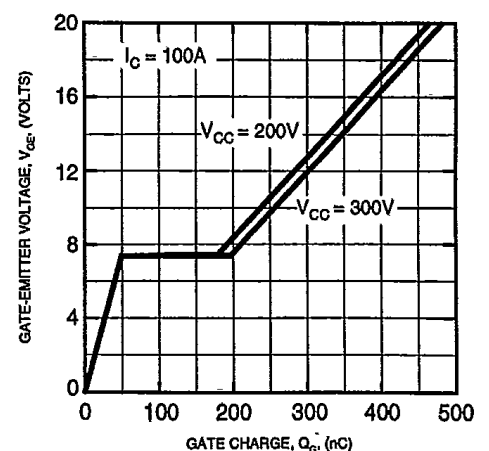

ID226010
Dual IGBTMOD™ Power Module
100 Amperes/600Volts

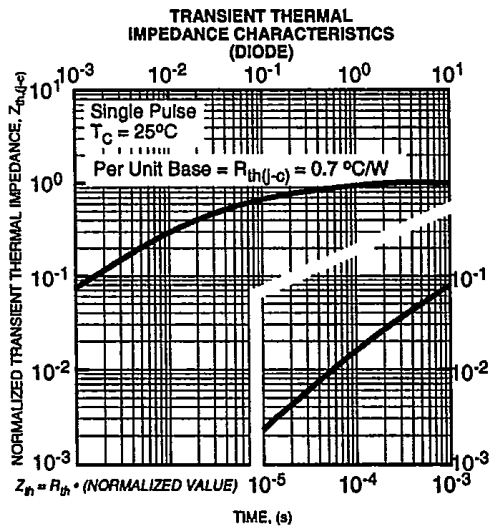
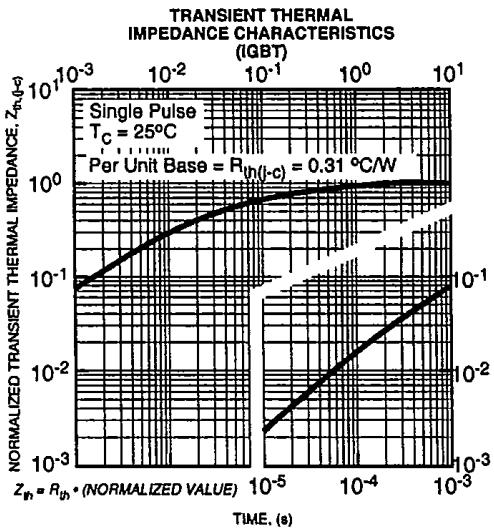

SWITCHING TIME TEST CIRCUITS & WAVEFORMS

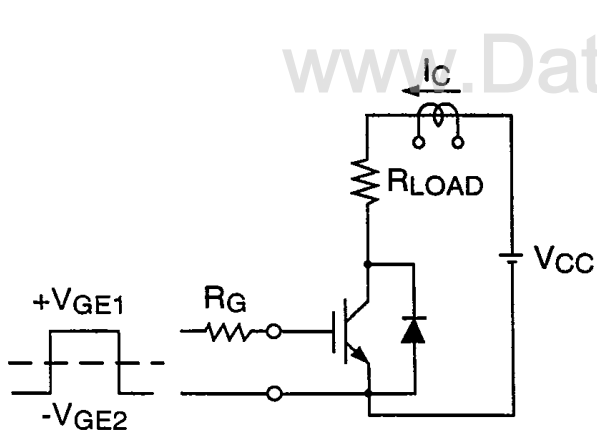

Resistance Load Switching Test Circuit

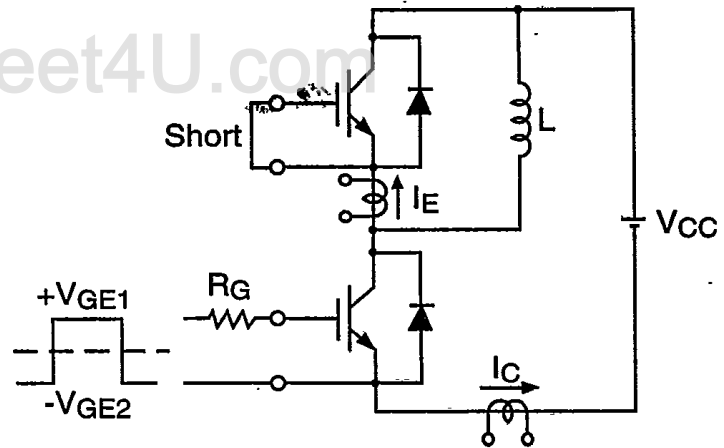

Half-Bridge Switching Test Circuit

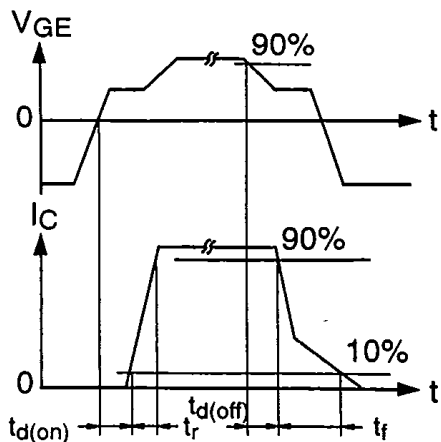

Switching Time Test Waveforms

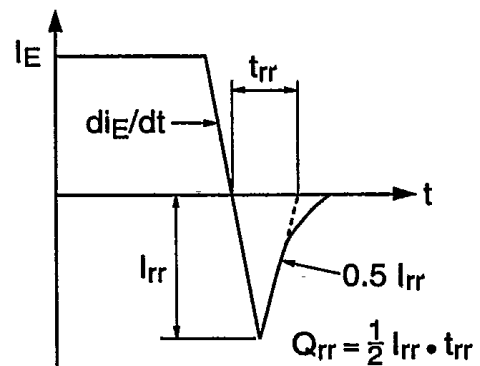

t_{rr} , Q_{rr} Waveforms