



FEATURES:

- 0.5 MICRON CMOS Technology
- Typical $t_{sk(o)}$ (Output Skew) < 250ps
- ESD > 2000V per MIL-STD-883, Method 3015; > 200V using machine model (C = 200pF, R = 0)
- $V_{cc} = 3.3V \pm 0.3V$, Normal Range, or $V_{cc} = 2.7V$ to $3.6V$, Extended Range
- CMOS power levels (0.4 μ W typ. static)
- Rail-to-rail output swing for increased noise margin
- Low Ground Bounce (0.3V typ.)
- Inputs (except I/O) can be driven by 3.3V or 5V components
- Available in TSSOP package

DESCRIPTION:

The FCT163827 20-bit buffer is built using advanced dual metal CMOS technology. These 20-bit bus drivers provide high-performance bus interface buffering for wide data/address paths or busses carrying parity. Two pairs of NAND-ed output enable controls offer maximum control flexibility and are organized to operate the device as two 10-bit buffers or one 20-bit buffer. Flow-through organization of signal pins simplifies layout. All inputs are designed with hysteresis for improved noise margin.

The FCT163827 has series current limiting resistors. This offers low ground bounce, minimal undershoot, and controlled output fall times, reducing the need for external series terminating resistors.

The inputs of the FCT163827 can be driven from either 3.3V or 5V devices. This feature allows the use of these devices as translators in a mixed 3.3V/5V supply system.

FUNCTIONAL BLOCK DIAGRAM

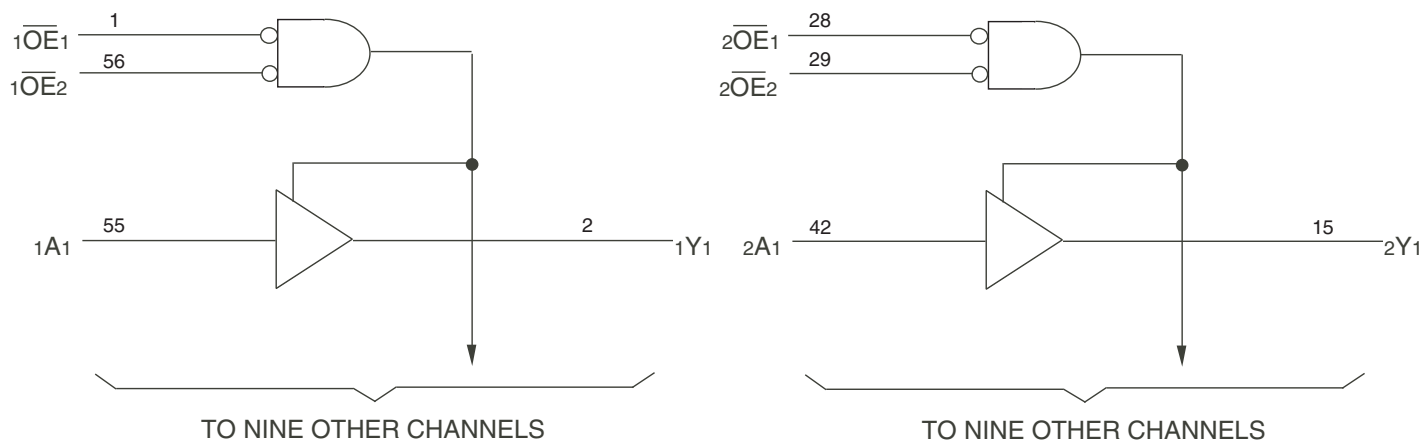

PIN CONFIGURATION

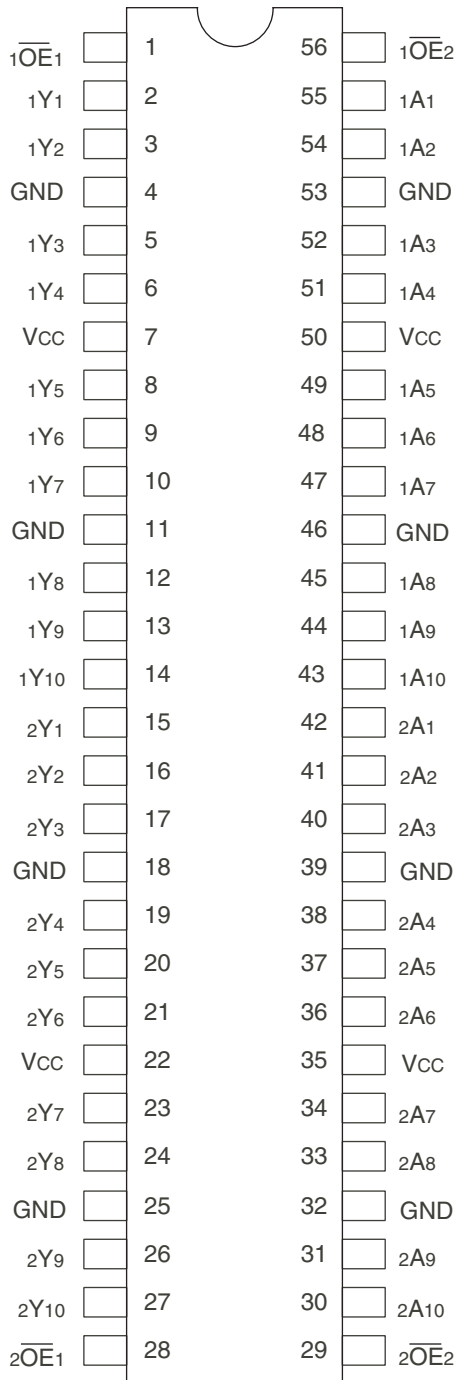

TOP VIEW

Package Type	Package Code	Order Code
TSSOP	PAG56	PAG

ABSOLUTE MAXIMUM RATINGS⁽¹⁾

Symbol	Description	Max	Unit
VTERM ⁽²⁾	Terminal Voltage with Respect to GND	-0.5 to +4.6	V
VTERM ⁽³⁾	Terminal Voltage with Respect to GND	-0.5 to 7	V
VTERM ⁽⁴⁾	Terminal Voltage with Respect to GND	-0.5 to VCC+0.5	V
TSTG	Storage Temperature	-65 to +150	°C
IOUT	DC Output Current	-60 to +60	mA

NOTES:

- Stresses greater than those listed under ABSOLUTE MAXIMUM RATINGS may cause permanent damage to the device. This is a stress rating only and functional operation of the device at these or any other conditions above those indicated in the operational sections of this specification is not implied. Exposure to absolute maximum rating conditions for extended periods may affect reliability.
- Vcc terminals.
- Input terminals.
- Outputs and I/O terminals.

CAPACITANCE (TA = +25°C, F = 1.0MHz)

Symbol	Parameter ⁽¹⁾	Conditions	Typ.	Max.	Unit
CIN	Input Capacitance	VIN = 0V	3.5	6	pF
COU	Output Capacitance	VOU = 0V	3.5	8	pF

NOTE:

- This parameter is measured at characterization but not tested.

PIN DESCRIPTION

Pin Names	Description
xOE _x	Output Enable Inputs (Active LOW)
xAX	Data Inputs
xY _x	3-State Outputs

FUNCTION TABLE⁽¹⁾

Inputs			Outputs
xOE ₁	xOE ₂	xAX	xY _x
L	L	L	L
L	L	H	H
H	X	X	Z
X	H	X	Z

NOTE:

- H = HIGH Voltage Level
L = LOW Voltage Level
X = Don't Care
Z = High-impedance

DC ELECTRICAL CHARACTERISTICS OVER OPERATING RANGE

Following Conditions Apply Unless Otherwise Specified:

Industrial: $T_A = -40^{\circ}\text{C}$ to $+85^{\circ}\text{C}$, $V_{CC} = 2.7\text{V}$ to 3.6V

Symbol	Parameter	Test Conditions ⁽¹⁾	Min.	Typ. ⁽²⁾	Max.	Unit	
V_{IH}	Input HIGH Level (Input pins)	Guaranteed Logic HIGH Level	2	—	5.5	V	
	Input HIGH Level (I/O pins)		2	—	$V_{CC}+0.5$		
V_{IL}	Input LOW Level (Input and I/O pins)	Guaranteed Logic LOW Level	-0.5	—	0.8	V	
I_{IH}	Input HIGH Current (Input pins)	$V_{CC} = \text{Max.}$	$V_I = 5.5\text{V}$	—	—	± 1	μA
	Input HIGH Current (I/O pins)		$V_I = V_{CC}$	—	—	± 1	
I_{IL}	Input LOW Current (Input pins)		$V_I = \text{GND}$	—	—	± 1	
	Input LOW Current (I/O pins)		$V_I = \text{GND}$	—	—	± 1	
I_{OZH}	High Impedance Output Current	$V_{CC} = \text{Max.}$	$V_O = V_{CC}$	—	—	± 1	μA
I_{OZL}	(3-State Output pins)		$V_O = \text{GND}$	—	—	± 1	
V_{IK}	Clamp Diode Voltage	$V_{CC} = \text{Min.}, I_{IN} = -18\text{mA}$	—	-0.7	-1.2	V	
I_{ODH}	Output HIGH Current	$V_{CC} = 3.3\text{V}, V_{IN} = V_{IH}$ or $V_{IL}, V_O = 1.5\text{V}^{(3)}$	-36	-60	-110	mA	
I_{ODL}	Output LOW Current	$V_{CC} = 3.3\text{V}, V_{IN} = V_{IH}$ or $V_{IL}, V_O = 1.5\text{V}^{(3)}$	50	90	200	mA	
V_{OH}	Output HIGH Voltage	$V_{CC} = \text{Min.}$	$I_{OH} = -0.1\text{mA}$	$V_{CC}-0.2$	—	—	V
		$V_{IN} = V_{IH}$ or V_{IL}	$I_{OH} = -3\text{mA}$	2.4	3	—	
		$V_{CC} = 3\text{V}$	$I_{OH} = -8\text{mA}$	2.4 ⁽⁵⁾	3	—	
V_{OL}	Output LOW Voltage	$V_{CC} = \text{Min.}$	$I_{OL} = 0.1\text{mA}$	—	—	0.2	V
			$I_{OL} = 16\text{mA}$	—	0.2	0.4	
			$I_{OL} = 24\text{mA}$	—	0.3	0.55	
		$V_{CC} = 3\text{V}$	$I_{OL} = 24\text{mA}$	—	0.3	0.5	
I_{OS}	Short Circuit Current ⁽⁴⁾	$V_{CC} = \text{Max.}, V_O = \text{GND}^{(3)}$	—	—	—	—	
			—	—	—	—	
V_H	Input Hysteresis	—	—	150	—	mV	
I_{CCL} I_{CCH} I_{CCZ}	Quiescent Power Supply Current	$V_{CC} = \text{Max.}$ $V_{IN} = \text{GND}$ or V_{CC}	—	0.1	10	μA	

NOTES:

1. For conditions shown as Min. or Max., use appropriate value specified under Electrical Characteristics for the applicable device type.
2. Typical values are at $V_{CC} = 3.3\text{V}$, $+25^{\circ}\text{C}$ ambient.
3. Not more than one output should be shorted at one time. Duration of the test should not exceed one second.
4. This parameter is guaranteed but not tested.
5. $V_{OH} = V_{CC}-0.6\text{V}$ at rated current.

POWER SUPPLY CHARACTERISTICS

Symbol	Parameter	Test Conditions ⁽¹⁾		Min.	Typ. ⁽²⁾	Max.	Unit
ΔI_{CC}	Quiescent Power Supply Current TTL Inputs HIGH	$V_{CC} = \text{Max.}$ $V_{IN} = V_{CC} - 0.6V^{(3)}$		—	2	30	μA
I_{CCD}	Dynamic Power Supply Current ⁽⁴⁾	$V_{CC} = \text{Max.}$ Outputs Open $\overline{xOE}_1 = \overline{xOE}_2 = \text{GND}$ One Input Toggling 50% Duty Cycle	$V_{IN} = V_{CC}$ $V_{IN} = \text{GND}$	—	50	75	$\mu A / \text{MHz}$
I_C	Total Power Supply Current ⁽⁶⁾	$V_{CC} = \text{Max.}, \text{Outputs Open}$ $f_i = 10\text{MHz}$ 50% Duty Cycle $\overline{xOE}_1 = \overline{xOE}_2 = \text{GND}$ One Bit Toggling	$V_{IN} = V_{CC}$ $V_{IN} = \text{GND}$	—	0.5	0.7	mA
			$V_{IN} = V_{CC} - 0.6V$ $V_{IN} = \text{GND}$	—	0.5	0.8	
		$V_{CC} = \text{Max.}, \text{Outputs Open}$ $f_i = 2.5\text{MHz}$ 50% Duty Cycle $\overline{xOE}_1 = \overline{xOE}_2 = \text{GND}$ Twenty Bits Toggling	$V_{IN} = V_{CC}$ $V_{IN} = \text{GND}$	—	2.5	3.7 ⁽⁵⁾	
			$V_{IN} = V_{CC} - 0.6V$ $V_{IN} = \text{GND}$	—	2.5	4.1 ⁽⁵⁾	

NOTES:

1. For conditions shown as Min. or Max., use appropriate value specified under Electrical Characteristics for the applicable device type.

2. Typical values are at $V_{CC} = 3.3V$, $+25^\circ C$ ambient.

3. Per TTL driven input. All other inputs at V_{CC} or GND.

4. This parameter is not directly testable, but is derived for use in Total Power Supply Calculations.

5. Values for these conditions are examples of the I_{CC} formula. These limits are guaranteed but not tested.

6. $I_C = I_{QUIESCENT} + I_{INPUTS} + I_{DYNAMIC}$

$I_C = I_{CC} + \Delta I_{CC} D_H N_T + I_{CCD} (f_{CP} N_{CP} / 2 + f_i N_i)$

$I_{CC} = \text{Quiescent Current (} I_{CCL}, I_{CCH} \text{ and } I_{CCZ} \text{)}$

$\Delta I_{CC} = \text{Power Supply Current for a TTL High Input}$

$D_H = \text{Duty Cycle for TTL Inputs High}$

$N_T = \text{Number of TTL Inputs at } D_H$

$I_{CCD} = \text{Dynamic Current caused by an Input Transition Pair (HLH or LHL)}$

$f_{CP} = \text{Clock Frequency for Register Devices (Zero for Non-Register Devices)}$

$N_{CP} = \text{Number of Clock Inputs at } f_{CP}$

$f_i = \text{Input Frequency}$

$N_i = \text{Number of Inputs at } f_i$

SWITCHING CHARACTERISTICS OVER OPERATING RANGE⁽¹⁾

Symbol	Parameter	Condition ⁽²⁾	FCT163827A		FCT163827C		Unit
			Min. ⁽³⁾	Max.	Min. ⁽³⁾	Max.	
tPLH tPHL	Propagation Delay xAx to xYx	CL = 50pF RL = 500Ω	1.5	8	1.5	4.4	ns
		CL = 300pF ⁽⁴⁾ RL = 500Ω	1.5	15	1.5	10	
tPZH tPZL	Output Enable Time xOE \bar{x} to xYx	CL = 50pF RL = 500Ω	1.5	12	1.5	7	ns
		CL = 300pF ⁽⁴⁾ RL = 500Ω	1.5	23	1.5	14	
tPHZ tPLZ	Output Disable Time xOE \bar{x} to xYx	CL = 5pF ⁽⁴⁾ RL = 500Ω	1.5	9	1.5	5.7	ns
		CL = 50pF RL = 500Ω	1.5	10	1.5	6	
tSk(o)	Output Skew ⁽³⁾		—	0.5	—	0.5	ns

NOTES:

1. See test circuit and waveforms.
2. Minimum limits are guaranteed but not tested.
3. Skew between any two outputs, of the same package, switching in the same direction. This parameter is guaranteed by design.
4. Propagation Delays and Enable/Disable times are with Vcc = 3.3V ±0.3V, Normal Range. For Vcc = 2.7V to 3.6V, Extended Range, all Propagation Delays and Enable/Disable times should be degraded by 20%.

TEST CIRCUITS AND WAVEFORMS

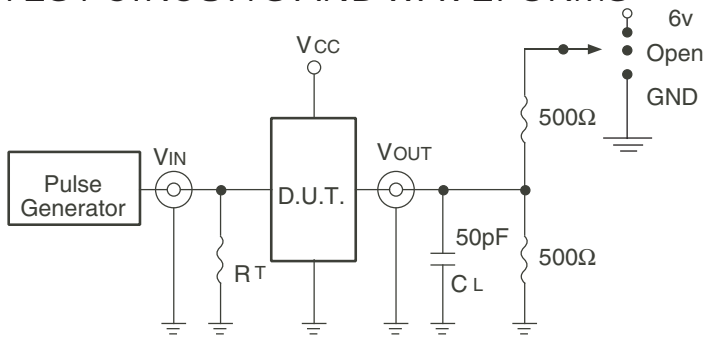

Test Circuits for All Outputs

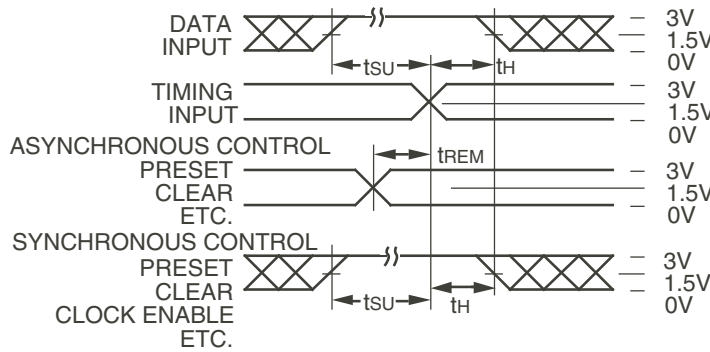

Set-up, Hold, and Release Times

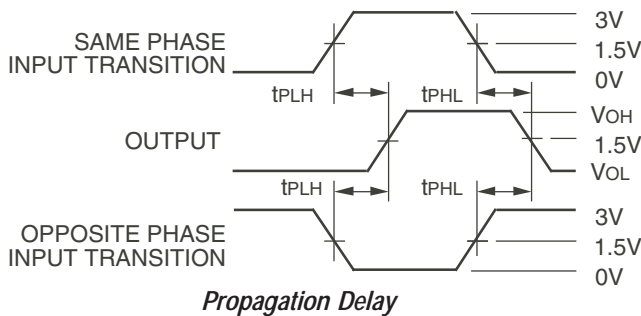

Propagation Delay

SWITCH POSITION

Test	Switch
Open Drain Disable Low Enable Low	6V
Disable High Enable High	GND
All Other Tests	Open

DEFINITIONS:

CL = Load capacitance: includes jig and probe capacitance.
RT = Termination resistance: should be equal to ZOUT of the Pulse Generator.

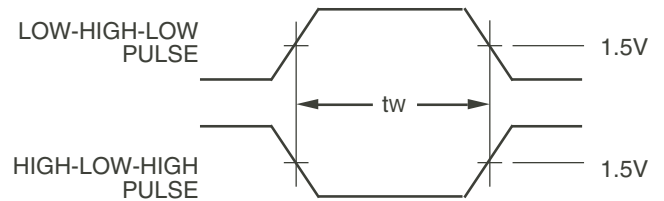

Pulse Width

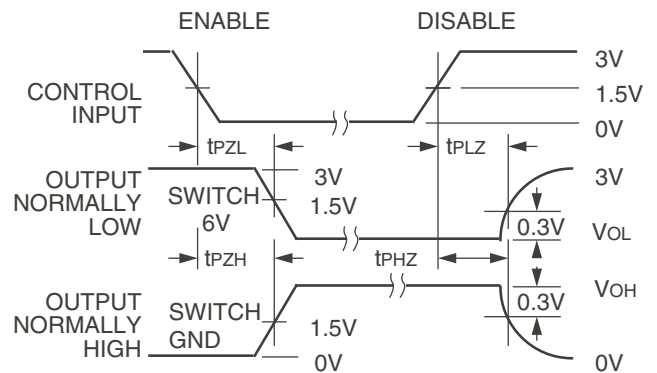

Enable and Disable Times

NOTES:

1. Diagram shown for input Control Enable-LOW and input Control Disable-HIGH.
2. Pulse Generator for All Pulses: Rate $\leq 1.0\text{MHz}$; $t_r \leq 2.5\text{ns}$; $t_f \leq 2.5\text{ns}$.
3. If V_{cc} is below 3V, input voltage swings should be adjusted not to exceed V_{cc} .

ORDERING INFORMATION

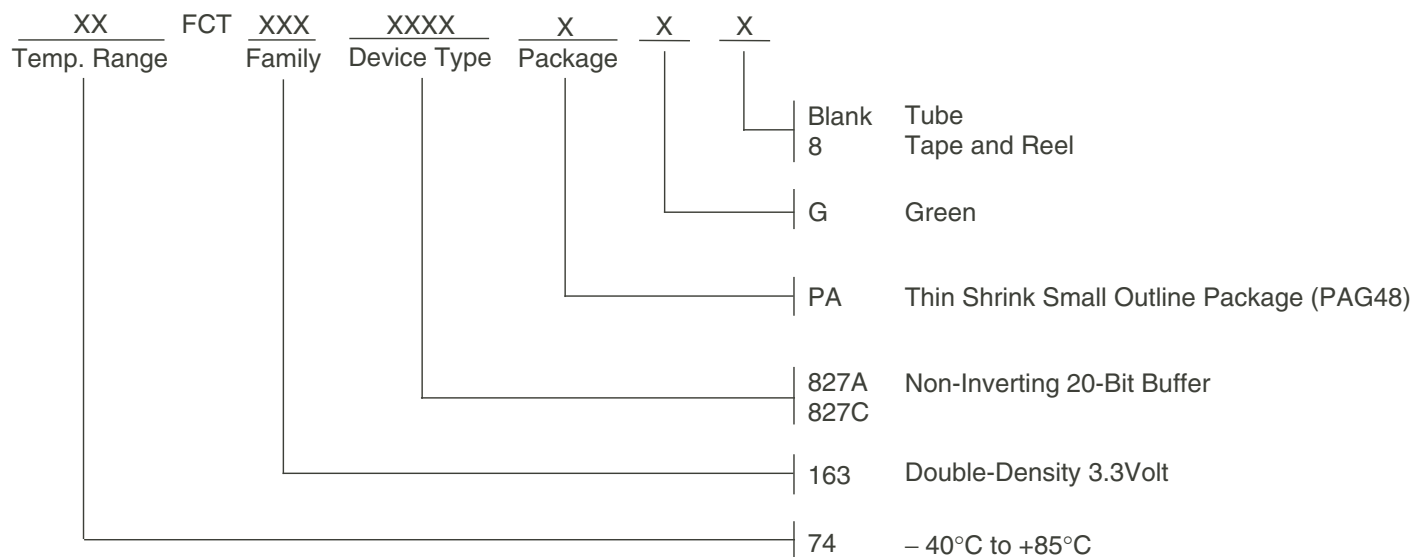

Orderable Part Information

Speed (ns)	Orderable Part ID	Pkg. Code	Pkg. Type	Temp. Grade
A	74FCT163827APAG	PAG56	TSSOP	I
	74FCT163827APAG8	PAG56	TSSOP	I
C	74FCT163827CPAG	PAG56	TSSOP	I
	74FCT163827CPAG8	PAG56	TSSOP	I

Datasheet Document History

09/28/2009	Pg. 7	Updated the ordering information by removing the "IDT" notation and non RoHS part.
05/10/2018	Pg. 1, 2, 5, 7	Added table under pin configuration diagram with detailed package information. Updated the ordering information diagram adding Tube, Tape and Reel. Added orderable part information table.



CORPORATE HEADQUARTERS
6024 Silver Creek Valley Road
San Jose, CA 95138

for SALES:
800-345-7015 or 408-284-8200
fax: 408-284-2775
www.idt.com

for Tech Support:
logichelp@idt.com