

FEATURES:

- 0.5 MICRON CMOS Technology
- Guaranteed low skew < 700ps (max.)
- Low duty cycle distortion < 1ns (max.)
- Low CMOS power levels
- TTL compatible inputs and outputs
- Rail-to-rail output voltage swing
- High drive: -24mA I_{OH}, +64mA I_{OL}
- Two independent output banks with 3-state control
- 1:5 fanout per bank
- "Heartbeat" monitor output
- Available in SSOP and SOIC packages

DESCRIPTION:

The 49FCT805 is a non-inverting buffer/clock driver built using advanced dual metal CMOS technology. Each bank consists of two banks of drivers. Each bank drives five output buffers from a standard TTL compatible input. These devices feature a "heart-beat" monitor for diagnostics and PLL driving. The MON output is identical to all other outputs and complies with the output specifications in this document.

The 49FCT805 offers low capacitance inputs and hysteresis. Rail-to-rail output swing improves noise margin and allows easy interface with CMOS inputs.

FUNCTIONAL BLOCK DIAGRAM

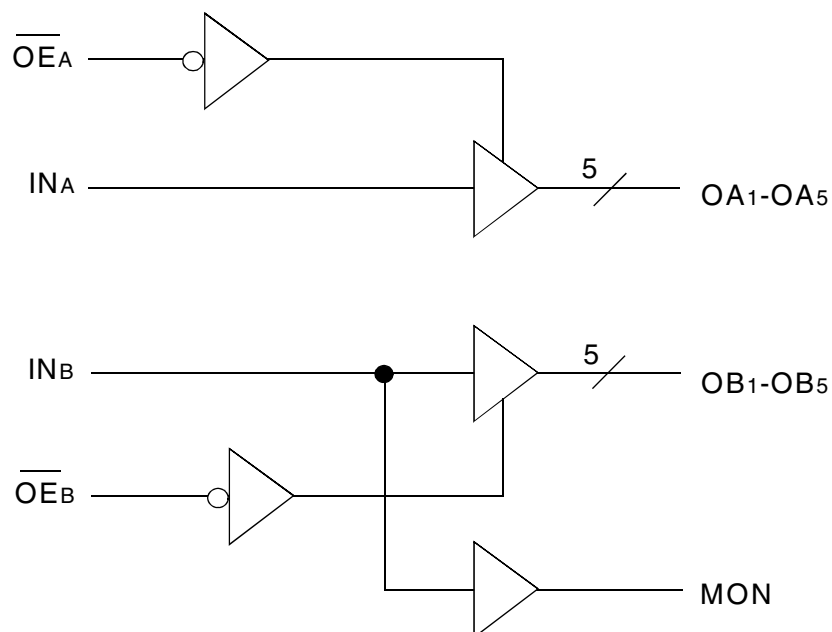

PIN CONFIGURATION

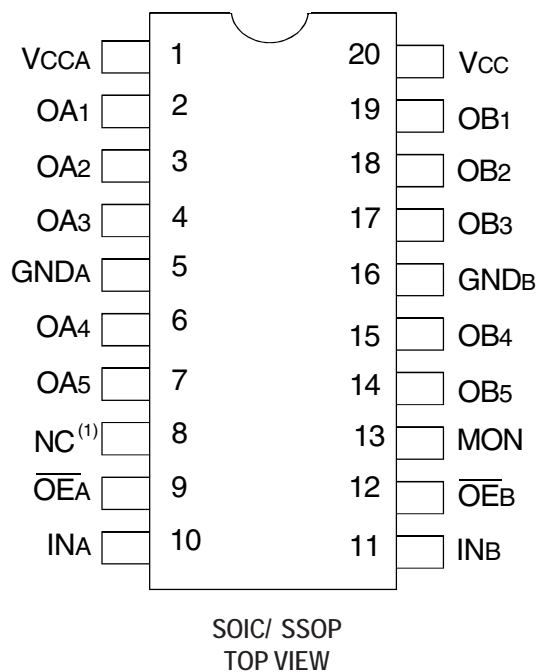

NOTE:

1. Pin 8 is not internally connected on devices with a "K" prefix in the date code. On older devices, pin 8 is internally connected to GND. To insure compatibility with all products, pin 8 should be connected to GND at the board level.

ABSOLUTE MAXIMUM RATINGS(1)

Symbol	Description	Max	Unit
V _{TERM} (2)	Terminal Voltage with Respect to GND	-0.5 to +7	V
V _{TERM} (3)	Terminal Voltage with Respect to GND	-0.5 to V _{CC} +0.5	V
T _{STG}	Storage Temperature	-65 to +150	°C
I _{OUT}	DC Output Current	-60 to +60	mA

NOTES:

1. Stresses greater than those listed under ABSOLUTE MAXIMUM RATINGS may cause permanent damage to the device. This is a stress rating only and functional operation of the device at these or any other conditions above those indicated in the operational sections of this specification is not implied. Exposure to absolute maximum rating conditions for extended periods may affect reliability.
2. Input and V_{CC} terminals.
3. Output and I/O terminals.

CAPACITANCE (T_A = +25°C, f = 1.0MHz)

Symbol	Parameter(1)	Conditions	Typ.	Max.	Unit
C _{IN}	Input Capacitance	V _{IN} = 0V	4.5	6	pF
C _{OUT}	Output Capacitance	V _{OUT} = 0V	5.5	8	pF

NOTE:

1. This parameter is measured at characterization but not tested.

PIN DESCRIPTION

Pin Names	Description
OE _A , OE _B	3-State Output Enable Inputs (Active LOW)
IN _A , IN _B	Clock Inputs
OA _n , OB _n	Clock Outputs
MON	Monitor Output

FUNCTION TABLE (1)

Inputs		Outputs	
OE _A , OE _B	IN _A , IN _B	OA _n , OB _n	MON
L	L	L	L
L	H	H	H
H	L	Z	L
H	H	Z	H

NOTE:

1. H = HIGH
L = LOW
Z = High-Impedance

DC ELECTRICAL CHARACTERISTICS OVER OPERATING RANGE

Following Conditions Apply Unless Otherwise Specified: $V_{LC} = 0.2V$; $V_{HC} = V_{CC} - 0.2V$

Commercial: $T_A = 0^\circ C$ to $+70^\circ C$, Industrial: $T_A = -40^\circ C$ to $+85^\circ C$, $V_{CC} = 5V \pm 5\%$

Symbol	Parameter	Test Conditions ⁽¹⁾		Min.	Typ. ⁽²⁾	Max.	Unit
V_{IH}	Input HIGH Level (Input pins)	Guaranteed Logic HIGH Level		2	—	—	V
V_{IL}	Input LOW Level (Input and I/O pins)	Guaranteed Logic LOW Level		—	—	0.8	V
I_{IH}	Input HIGH Current	$V_{CC} = \text{Max.}$	$V_I = 5.5V$	—	—	± 1	μA
I_{IL}	Input LOW Current	$V_{CC} = \text{Max.}$	$V_I = \text{GND}$	—	—	± 1	μA
I_{OZH}	Off State (Hi-Z) Output Current	$V_{CC} = \text{Max.}$	$V_O = V_{CC}$	—	—	± 1	μA
I_{OZL}			$V_O = \text{GND}$	—	—	± 1	
V_{IK}	Clamp Diode Voltage	$V_{CC} = \text{Min.}, I_{IN} = -18mA$		—	-0.7	-1.2	V
I_{OS}	Short Circuit Current	$V_{CC} = \text{Max.}, V_O = \text{GND}^{(3)}$		-60	-120	—	mA
V_{OH}	Output HIGH Voltage	$V_{CC} = 3V, V_{IN} = V_{LC}$ or V_{HC}	$I_{OH} = -32\mu A$	V_{HC}	V_{CC}	—	V
		$V_{CC} = \text{Min.}$	$I_{OH} = -300\mu A$	V_{HC}	V_{CC}	—	
		$V_{IN} = V_{IH}$ or V_{IL}	$I_{OH} = -15mA$	3.6	4.3	—	
			$I_{OH} = -24mA$	2.4	3.8	—	
V_{OL}	Output LOW Voltage	$V_{CC} = 3V, V_{IN} = V_{LC}$ or V_{HC}	$I_{OL} = 300\mu A$	—	GND	V_{LC}	V
		$V_{CC} = \text{Min.}$	$I_{OL} = 300mA$	—	GND	V_{LC}	
		$V_{IN} = V_{IH}$ or V_{IL}	$I_{OL} = 64mA$	—	0.3	0.55	
V_H	Input Hysteresis for all inputs	—		—	200	—	mV
I_{CC}	Quiescent Power Supply Current	$V_{CC} = \text{Max.}, V_{IN} = \text{GND}$ or V_{CC}		—	5	500	μA

NOTES:

1. For conditions shown as Max. or Min., use appropriate value specified under Electrical Characteristics for the applicable device type.
2. Typical values are at $V_{CC} = 5V$, $+25^\circ C$ ambient.
3. Not more than one output should be shorted at one time. Duration of the test should not exceed one second.

POWER SUPPLY CHARACTERISTICS

Symbol	Parameter	Test Conditions ⁽¹⁾		Min.	Typ. ⁽²⁾	Max.	Unit
ΔI_{CC}	Quiescent Power Supply Current TTL Inputs HIGH	V _{CC} = Max. V _{IN} = 3.4V ⁽³⁾		—	1	2.5	mA
I _{CCD}	Dynamic Power Supply Current ⁽⁴⁾	V _{CC} = Max. Outputs Open OEA = OEB = GND 50% Duty Cycle	V _{IN} = V _{CC} V _{IN} = GND	—	0.15	0.2	mA/MHz
I _C	Total Power Supply Current ⁽⁶⁾	V _{CC} = Max. Outputs Open f _o = 10MHz 50% Duty Cycle OEA = OEB = V _{CC} Mon. Output Toggling	V _{IN} = V _{CC} V _{IN} = GND	—	1.5	2.5	mA
			V _{IN} = 3.4V V _{IN} = GND	—	2	3.8	
		V _{CC} = Max. Outputs Open f _o = 2.5MHz 50% Duty Cycle OEA = OEB = GND Eleven Outputs Toggling	V _{IN} = V _{CC} V _{IN} = GND	—	4.1	6 ⁽⁵⁾	
			V _{IN} = 3.4V V _{IN} = GND	—	5.1	8.5 ⁽⁵⁾	

NOTES:

- For conditions shown as Max. or Min., use appropriate value specified under Electrical Characteristics for the applicable device type.
- Typical values are at V_{CC} = 5V, +25°C ambient.
- Per TTL driven input (V_{IN} = 3.4V); all other inputs at V_{CC} or GND.
- This parameter is not directly testable, but is derived for use in Total Power Supply calculations.
- Values for these conditions are examples of the I_C formula. These limits are guaranteed but not tested.
- I_C = I_{QUIESCENT} + I_{INPUTS} + I_{DYNAMIC}
 $I_C = I_{CC} + \Delta I_{CC} D_H N_T + I_{CCD} (f_o N_o)$
 I_{CC} = Quiescent Current (I_{CC1}, I_{CC2} and I_{CC3})
 ΔI_{CC} = Power Supply Current for a TTL High Input (V_{IN} = 3.4V)
 D_H = Duty Cycle for TTL Inputs High
 N_T = Number of TTL Inputs at D_H
 I_{CCD} = Dynamic Current Caused by an Input Transition Pair (HLH or LHL)
 f_o = Output Frequency
 N_o = Number of Outputs at f_o
 All currents are in milliamps and all frequencies are in megahertz.

SWITCHING CHARACTERISTICS OVER OPERATING RANGE⁽¹⁾

Symbol	Parameter	Conditions ⁽²⁾	FCT805		FCT805A		Unit
			Min.	Max.	Min.	Max.	
t _{PLH}	Propagation Delay	C _L = 50pF R _L = 500Ω	1.5	5.6	1.5	5.3	ns
t _{PHL}	I _{NA} to O _{AN} , I _{NB} to O _{BN}		—	1.5	—	1.5	ns
t _R	Output Rise Time		—	1.5	—	1.5	ns
t _F	Output Fall Time		—	1.5	—	1.5	ns
t _{SK(O)}	Output skew: skew between outputs of all banks of same package (inputs tied together)		—	0.7	—	0.7	ns
t _{SK(P)}	Pulse skew: skew between opposite transitions of same output (t _{PHL} - t _{PLH})		—	1	—	1	ns
t _{SK(PP)}	Part-to-part skew: skew between outputs of different packages at same power supply voltage, temperature, package type and speed grade		—	1.5	—	1.5	ns
t _{PZL}	Output Enable Time		1.5	8	1.5	8	ns
t _{PZH}	O _{EA} to O _{AN} , O _{EB} to O _{BN}		1.5	7	1.5	7	ns
t _{PLZ}	Output Disable Time	1.5	7	1.5	7	ns	
t _{PHZ}	O _{EA} to O _{AN} , O _{EB} to O _{BN}	1.5	7	1.5	7	ns	

NOTES:

1. Propagation delay range indicated by Min. and Max. limit is due to V_{cc}, operating temperature and process parameters. These propagation delay limits do not imply skew.
2. See test circuits and waveforms.

TEST CIRCUITS AND WAVEFORMS

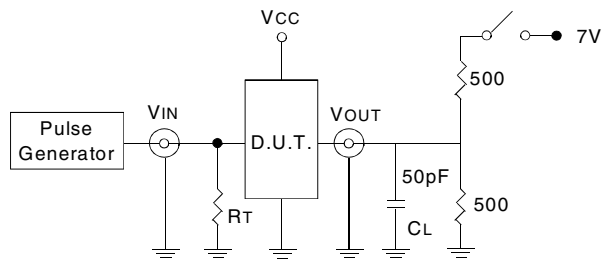

Test Circuits for All Outputs

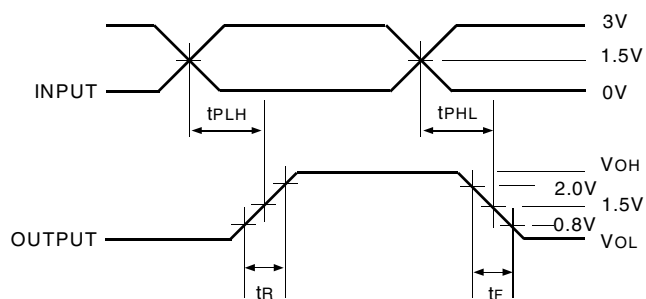

Package Delay

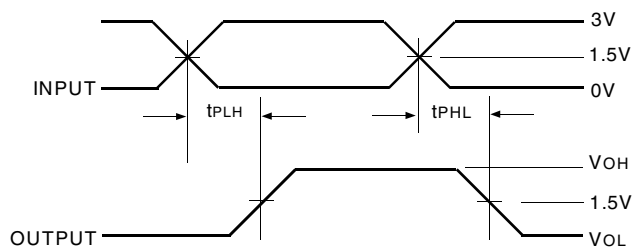

$$tsk(p) = |t_{PHL} - t_{PLH}|$$

Pulse Skew - $tsk(P)$

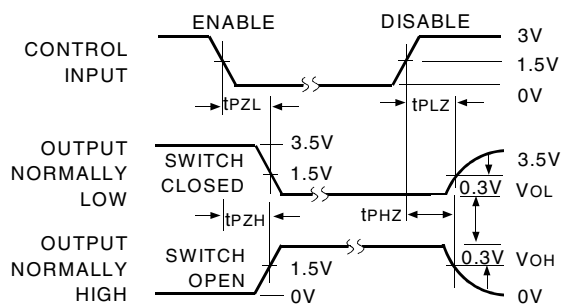

Enable and Disable Times

SWITCH POSITION

Test	Switch
Disable LOW Enable LOW	Closed
Disable HIGH Enable HIGH	GND

DEFINITIONS:

CL = Load capacitance: includes jig and probe capacitance.

RT = Termination resistance: should be equal to Zout of the Pulse Generator.

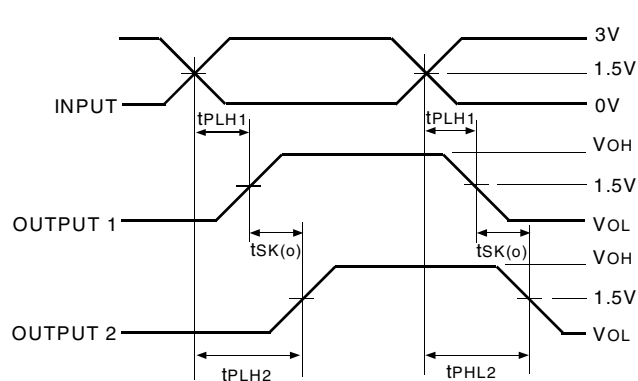

$$tsk(o) = |t_{PLH2} - t_{PLH1}| \text{ or } |t_{PHL2} - t_{PHL1}|$$

Output Skew

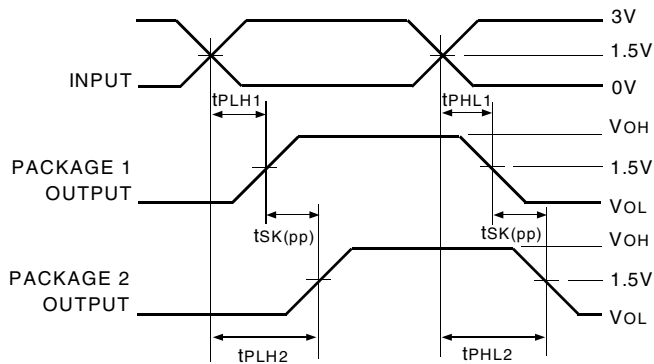

$$tsk(pp) = |t_{PLH2} - t_{PLH1}| \text{ or } |t_{PHL2} - t_{PHL1}|$$

Part-to-Part Skew - $tsk(PP)$

NOTE:

1. Package 1 and Package 2 are same device type and speed grade.

NOTES:

1. Diagram shown for input Control Enable-LOW and input Control Disable-HIGH
2. Pulse Generator for All Pulses: Rate $\leq 1.0\text{MHz}$; $t_r \leq 2.5\text{ns}$; $t_f \leq 2.5\text{ns}$

ORDERING INFORMATION

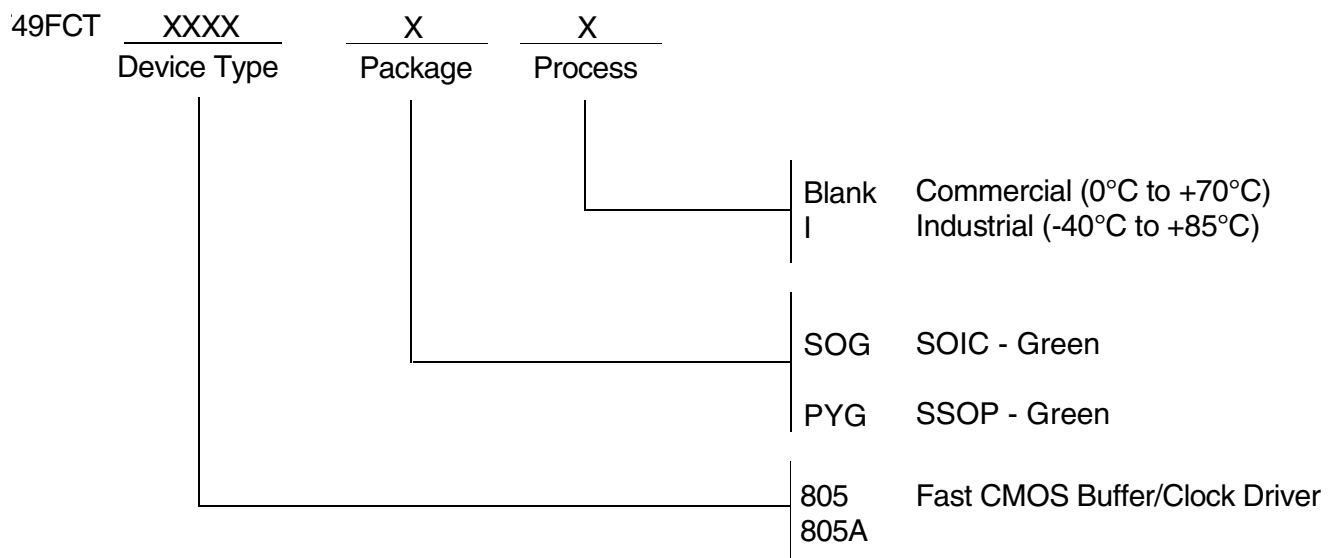

Notice

1. Descriptions of circuits, software and other related information in this document are provided only to illustrate the operation of semiconductor products and application examples. You are fully responsible for the incorporation or any other use of the circuits, software, and information in the design of your product or system. Renesas Electronics disclaims any and all liability for any losses and damages incurred by you or third parties arising from the use of these circuits, software, or information.
2. Renesas Electronics hereby expressly disclaims any warranties against and liability for infringement or any other claims involving patents, copyrights, or other intellectual property rights of third parties, by or arising from the use of Renesas Electronics products or technical information described in this document, including but not limited to, the product data, drawings, charts, programs, algorithms, and application examples.
3. No license, express, implied or otherwise, is granted hereby under any patents, copyrights or other intellectual property rights of Renesas Electronics or others.
4. You shall not alter, modify, copy, or reverse engineer any Renesas Electronics product, whether in whole or in part. Renesas Electronics disclaims any and all liability for any losses or damages incurred by you or third parties arising from such alteration, modification, copying or reverse engineering.
5. Renesas Electronics products are classified according to the following two quality grades: "Standard" and "High Quality". The intended applications for each Renesas Electronics product depends on the product's quality grade, as indicated below.
 - "Standard": Computers; office equipment; communications equipment; test and measurement equipment; audio and visual equipment; home electronic appliances; machine tools; personal electronic equipment; industrial robots; etc.
 - "High Quality": Transportation equipment (automobiles, trains, ships, etc.); traffic control (traffic lights); large-scale communication equipment; key financial terminal systems; safety control equipment; etc.Unless expressly designated as a high reliability product or a product for harsh environments in a Renesas Electronics data sheet or other Renesas Electronics document, Renesas Electronics products are not intended or authorized for use in products or systems that may pose a direct threat to human life or bodily injury (artificial life support devices or systems; surgical implantations; etc.), or may cause serious property damage (space system; undersea repeaters; nuclear power control systems; aircraft control systems; key plant systems; military equipment; etc.). Renesas Electronics disclaims any and all liability for any damages or losses incurred by you or any third parties arising from the use of any Renesas Electronics product that is inconsistent with any Renesas Electronics data sheet, user's manual or other Renesas Electronics document.
6. When using Renesas Electronics products, refer to the latest product information (data sheets, user's manuals, application notes, "General Notes for Handling and Using Semiconductor Devices" in the reliability handbook, etc.), and ensure that usage conditions are within the ranges specified by Renesas Electronics with respect to maximum ratings, operating power supply voltage range, heat dissipation characteristics, installation, etc. Renesas Electronics disclaims any and all liability for any malfunctions, failure or accident arising out of the use of Renesas Electronics products outside of such specified ranges.
7. Although Renesas Electronics endeavors to improve the quality and reliability of Renesas Electronics products, semiconductor products have specific characteristics, such as the occurrence of failure at a certain rate and malfunctions under certain use conditions. Unless designated as a high reliability product or a product for harsh environments in a Renesas Electronics data sheet or other Renesas Electronics document, Renesas Electronics products are not subject to radiation resistance design. You are responsible for implementing safety measures to guard against the possibility of bodily injury, injury or damage caused by fire, and/or danger to the public in the event of a failure or malfunction of Renesas Electronics products, such as safety design for hardware and software, including but not limited to redundancy, fire control and malfunction prevention, appropriate treatment for aging degradation or any other appropriate measures. Because the evaluation of microcomputer software alone is very difficult and impractical, you are responsible for evaluating the safety of the final products or systems manufactured by you.
8. Please contact a Renesas Electronics sales office for details as to environmental matters such as the environmental compatibility of each Renesas Electronics product. You are responsible for carefully and sufficiently investigating applicable laws and regulations that regulate the inclusion or use of controlled substances, including without limitation, the EU RoHS Directive, and using Renesas Electronics products in compliance with all these applicable laws and regulations. Renesas Electronics disclaims any and all liability for damages or losses occurring as a result of your noncompliance with applicable laws and regulations.
9. Renesas Electronics products and technologies shall not be used for or incorporated into any products or systems whose manufacture, use, or sale is prohibited under any applicable domestic or foreign laws or regulations. You shall comply with any applicable export control laws and regulations promulgated and administered by the governments of any countries asserting jurisdiction over the parties or transactions.
10. It is the responsibility of the buyer or distributor of Renesas Electronics products, or any other party who distributes, disposes of, or otherwise sells or transfers the product to a third party, to notify such third party in advance of the contents and conditions set forth in this document.
11. This document shall not be reprinted, reproduced or duplicated in any form, in whole or in part, without prior written consent of Renesas Electronics.
12. Please contact a Renesas Electronics sales office if you have any questions regarding the information contained in this document or Renesas Electronics products.

(Note1) "Renesas Electronics" as used in this document means Renesas Electronics Corporation and also includes its directly or indirectly controlled subsidiaries.

(Note2) "Renesas Electronics product(s)" means any product developed or manufactured by or for Renesas Electronics.

(Rev.4.0-1 November 2017)

Corporate Headquarters

TOYOSU FORESIA, 3-2-24 Toyosu,
Koto-ku, Tokyo 135-0061, Japan
www.renesas.com

Contact Information

For further information on a product, technology, the most up-to-date version of a document, or your nearest sales office, please visit:
www.renesas.com/contact/

Trademarks

Renesas and the Renesas logo are trademarks of Renesas Electronics Corporation. All trademarks and registered trademarks are the property of their respective owners.