



Integrated Device Technology, Inc.

HIGH-SPEED CMOS OCTAL BUFFER/LINE DRIVER

IDT54/74AHCT244

FEATURES:

- Equivalent to ALS speeds and output drive over full temperature and voltage supply extremes
- 7ns typical data to output delay
- $I_{OL} = 14\text{mA}$ over full military temperature range
- CMOS power levels ($5\mu\text{W}$ typ. static)
- Both CMOS and TTL output compatible
- Substantially lower input current levels than ALS ($5\mu\text{A}$ max.)
- Octal buffer/line driver with 3-state output
- 100% product assurance screening to MIL-STD-883, Class B is available
- JEDEC standard pinout for DIP and LCC

DESCRIPTION:

The IDT54/74AHCT244 are octal buffer/line drivers built using advanced CEMOS™, a dual metal CMOS technology. The devices are designed to be employed as memory and address drivers, clock drivers and bus-oriented transmitters/receivers which provide improved board density.

PIN CONFIGURATIONS

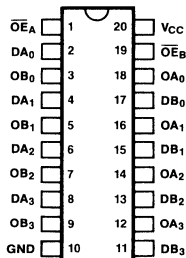

SSD54/74AHCT244-001

DIP
TOP VIEW

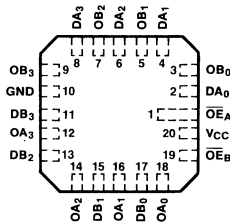

SSD54/74AHCT244-002

LCC
TOP VIEW

FUNCTIONAL BLOCK DIAGRAM

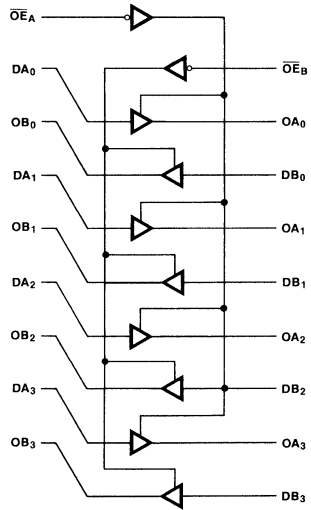

SSD54/74AHCT244-005

5

CEMOS is a trademark of Integrated Device Technology, Inc.

MILITARY AND COMMERCIAL TEMPERATURE RANGES

JULY 1986

© 1986 Integrated Device Technology, Inc.

Printed in U.S.A.

ABSOLUTE MAXIMUM RATING⁽¹⁾

| SYMBOL | RATING | COMMERCIAL | MILITARY | UNIT |
|-------------------|--------------------------------------|--------------|--------------|------|
| V _{TERM} | Terminal Voltage with Respect to GND | -0.5 to +7.0 | -0.5 to +7.0 | V |
| T _A | Operating Temperature | 0 to +70 | -55 to +125 | °C |
| T _{BIAS} | Temperature Under Bias | -55 to +125 | -65 to +135 | °C |
| T _{STG} | Storage Temperature | -55 to +125 | -65 to +155 | °C |
| I _{OUT} | DC Output Current | 120 | 120 | mA |

NOTE:

1. Stresses greater than those listed under ABSOLUTE MAXIMUM RATINGS may cause permanent damage to the device. This is a stress rating only and functional operation of the device at these or any other conditions above those indicated in the operational sections of this specification is not implied. Exposure to absolute maximum rating conditions for extended periods may affect reliability.

DC ELECTRICAL CHARACTERISTICS OVER OPERATING RANGE

Following Conditions Apply Unless Otherwise Specified:

| | | | |
|--|------------------------------|--------------|---------------------------|
| T _A = 0°C to +70°C | V _{CC} = 5.0V ± 5% | Min. = 4.75V | Max. = 5.25V (Commercial) |
| T _A = -55°C to +125°C | V _{CC} = 5.0V ± 10% | Min. = 4.50V | Max. = 5.50V (Military) |
| V _{LC} = 0.2V | | | |
| V _{HC} = V _{CC} - 0.2V | | | |

| SYMBOL | PARAMETER | TEST CONDITIONS ⁽¹⁾ | MIN. | TYP. ⁽²⁾ | MAX. | UNIT | |
|-----------------|-----------------------|--|-----------------------------|---------------------|-----------------|------|-----------------|
| V _{IH} | Input HIGH Level | Guaranteed Logic High Level | 2.0 | — | — | V | |
| V _{IL} | Input LOW Level | Guaranteed Logic Low Level | — | — | 0.8 | V | |
| I _{IH} | Input HIGH Current | V _{CC} = Max., V _{IN} = V _{CC} | — | — | 5 | μA | |
| I _{IL} | Input LOW Current | V _{CC} = Max., V _{IN} = GND | — | — | -5 | μA | |
| I _{SC} | Short Circuit Current | V _{CC} = Max. ⁽³⁾ | -60 | -100 | — | mA | |
| V _{OH} | Output HIGH Voltage | V _{CC} = 3V, V _{IN} = V _{LC} or V _{HC} , I _{OH} = -32μA | V _{HC} | V _{CC} | — | V | |
| | | V _{CC} = Min. V _{IN} = V _{IH} or V _{IL} | I _{OH} = -150μA | V _{HC} | V _{CC} | | — |
| | | | I _{OH} = -12mA MIL | 2.4 | 4.3 | | — |
| V _{OL} | Output LOW Voltage | V _{CC} = 3V, V _{IN} = V _{LC} or V _{HC} , I _{OL} = 300μA | — | GND | V _{LC} | V | |
| | | V _{CC} = Min. V _{IN} = V _{IH} or V _{IL} | I _{OL} = 300μA | — | GND | | V _{LC} |
| | | | I _{OL} = 14mA MIL | — | — | | 0.4 |
| | | | I _{OL} = 24mA COM | — | — | | 0.5 |

NOTES:

- For conditions shown as max. or min., use appropriate value specified under Electrical Characteristics for the applicable device type.
- Typical values are at V_{CC} = 5.0V, +25°C ambient and maximum loading.
- Not more than one output should be shorted at one time. Duration of the short circuit test should not exceed one second.

POWER SUPPLY CHARACTERISTICS

$V_{LC} = 0.2V$; $V_{HC} = V_{CC} - 0.2V$

| SYMBOL | PARAMETER | TEST CONDITIONS ⁽¹⁾ | | MIN. | TYP. ⁽²⁾ | MAX. | UNIT |
|-----------|---|--|---|------|---------------------|------|------------|
| I_{CCQ} | Quiescent Power Supply Current | $V_{CC} = \text{Max.}$ $V_{IN} \geq V_{HC}$; $V_{IN} \leq V_{LC}$ $f_i = 0$ | | — | 0.001 | 1.5 | mA |
| I_{CCT} | Power Supply Current Per TTL Inputs HIGH | $V_{CC} = \text{Max.}$ $V_{IN} = 3.4V$ ⁽³⁾ | | — | 0.5 | 1.6 | mA |
| I_{CCD} | Dynamic Power Supply Current | $V_{CC} = \text{Max.}$ Outputs Open $OE_A = OE_B = \text{GND}$ One Input Toggling 50% Duty Cycle | $V_{IN} \geq V_{HC}$ $V_{IN} \leq V_{LC}$ | — | 0.15 | 0.25 | mA/ MHz |
| I_{CC} | Total Power Supply ⁽⁴⁾ Current | $V_{CC} = \text{Max.}$ Outputs Open $f_i = 1.0\text{MHz}$ 50% Duty Cycle $OE_A = OE_B = \text{GND}$ One Bit Toggling | $V_{IN} \geq V_{HC}$ $V_{IN} \leq V_{LC}$ (AHCT) | — | 0.15 | 1.8 | mA |
| | | | $V_{IN} = 3.4V$ or $V_{IN} = \text{GND}$ | — | 0.4 | 2.6 | |
| | | $V_{CC} = \text{Max.}$ Outputs Open $f_i = 250\text{kHz}$ 50% Duty Cycle $OE_A = OE_B = \text{GND}$ Eight Bits Toggling | $V_{IN} \geq V_{HC}$ $V_{IN} \leq V_{LC}$ (AHCT) | — | 0.3 | 2.0 | |
| | | | $V_{IN} = 3.4V$ or $V_{IN} = \text{GND}$ | — | 2.3 | 8.4 | |

NOTES:

- For conditions shown as max. or min., use appropriate value specified under Electrical Characteristics for the applicable device type.
- Typical values are at $V_{CC} = 5.0V$, +25°C ambient and maximum loading.
- Per TTL driven input ($V_{IN} = 3.4V$); all other inputs at V_{CC} or GND.

4. $I_{CC} = I_{\text{QUIESCENT}} + I_{\text{INPUTS}} + I_{\text{DYNAMIC}}$

$I_{CC} = I_{CCQ} + I_{CCT}D_HN_T + I_{CCD}(f_{CP}/2 + f_iN_i)$

I_{CCQ} = Quiescent Current

I_{CCT} = Power Supply Current for a TTL High Input ($V_{IN} = 3.4V$)

D_H = Duty Cycle for TTL Inputs High

N_T = Number of TTL Inputs at D_H

I_{CCD} = Dynamic Current caused by an Input Transition pair (HLH or LHL)

f_{CP} = Clock Frequency for Register Devices (Zero for Non-Register Devices)

f_i = Input Frequency

N_i = Number of Inputs at f_i

All currents are in milliamps and all frequencies are in megahertz.

DEFINITION OF FUNCTIONAL TERMS

| PIN NAMES | DESCRIPTION |
|--------------|--|
| OE_A, OE_B | 3-State Output Enable Input (Active LOW) |
| Dxx | Inputs |
| Oxx | Outputs |

TRUTH TABLE

| INPUTS | | D | OUTPUT |
|--------|--------|---|--------|
| OE_A | OE_B | | |
| L | L | L | L |
| L | H | X | H |
| H | X | X | Z |

H = HIGH Voltage Level

L = LOW Voltage Level

X = Don't Care

Z = High Impedance

SWITCHING CHARACTERISTICS OVER OPERATING RANGE

| SYMBOL | PARAMETER | CONDITION | TYPICAL | COMMERCIAL | | MILITARY | | UNITS |
|------------------------|-------------------------------------|--|---------|------------|------|----------|------|-------|
| | | | | MIN. | MAX. | MIN. | MAX. | |
| t_{PLH} t_{PHL} | Propagation Delay D_N to O_N | $C_L = 50\text{pf}$ $R_L = 500\Omega$ | 7.0 | 3.0 | 10.0 | 3.0 | 13.0 | ns |
| t_{ZH} t_{ZL} | Output Enable Time | | 16.0 | 7.0 | 20.0 | 7.0 | 25.0 | ns |
| t_{HZ} t_{LZ} | Output Disable Time | | 10.0 | 2.0 | 13.0 | 2.0 | 18.0 | ns |

