



Integrated Device Technology, Inc.

HIGH-SPEED CMOS 8-BIT IDENTITY COMPARATOR

IDT54/74AHCT521

FEATURES:

- Equivalent to ALS speeds and output drive over full temperature and voltage supply extremes
- 9ns typical propagation delay
- $I_{OL} = 14\text{mA}$ over full military temperature range
- CMOS power levels ($5\mu\text{W}$ typ. static)
- Both CMOS and TTL output compatible
- Substantially lower input current levels than ALS ($5\mu\text{A}$ max.)
- 8-bit identity comparator
- 100% product assurance screening to MIL-STD-883, Class B is available
- JEDEC standard pinout for DIP and LCC

DESCRIPTION:

The IDT54/74AHCT521 is an 8-bit identity comparator built using advanced CEMOS™, a dual metal CMOS technology. The device compares two words of up to eight bits each and provides a LOW output when the two words match bit for bit. The expansion input $\bar{I}_{A=B}$ also serves as an active LOW enable input.

PIN CONFIGURATIONS

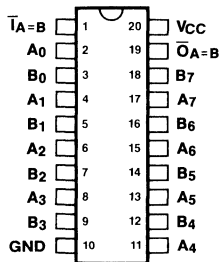

SSDAHCT521-001

DIP
TOP VIEW

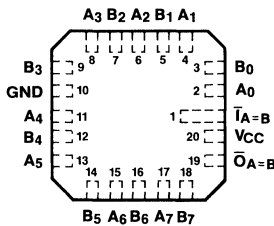

SSDAHCT521-002

LCC
TOP VIEW

FUNCTIONAL BLOCK DIAGRAM

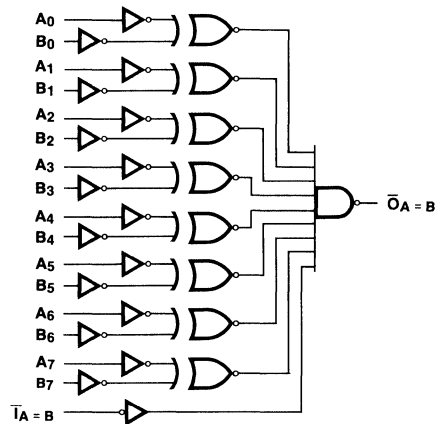

SSDAHCT521-003

5

CEMOS is a trademark of Integrated Device Technology, Inc.

MILITARY AND COMMERCIAL TEMPERATURE RANGES

JULY 1986

© 1986 Integrated Device Technology, Inc.

Printed in the U.S.A.

ABSOLUTE MAXIMUM RATING⁽¹⁾

SYMBOL	RATING	COMMERCIAL	MILITARY	UNIT
V_{TERM}	Terminal Voltage with Respect to GND	-0.5 to +7.0	-0.5 to +7.0	V
T_A	Operating Temperature	0 to +70	-55 to +125	°C
T_{BIAS}	Temperature Under Bias	-55 to +125	-65 to +135	°C
T_{STG}	Storage Temperature	-55 to +125	-65 to +155	°C
I_{OUT}	DC Output Current	120	120	mA

NOTE:

1. Stresses greater than those listed under ABSOLUTE MAXIMUM RATINGS may cause permanent damage to the device. This is a stress rating only and functional operation of the device at these or any other conditions above those indicated in the operational sections of this specification is not implied. Exposure to absolute maximum rating conditions for extended periods may affect reliability.

DC ELECTRICAL CHARACTERISTICS OVER OPERATING RANGE

Following Conditions Apply Unless Otherwise Specified:

$T_A = 0^\circ\text{C}$ to $+70^\circ\text{C}$	$V_{CC} = 5.0\text{V} \pm 5\%$	Min. = 4.75V	Max. = 5.25V (Commercial)
$T_A = -55^\circ\text{C}$ to $+125^\circ\text{C}$	$V_{CC} = 5.0\text{V} \pm 10\%$	Min. = 4.50V	Max. = 5.50V (Military)
$V_{LC} = 0.2\text{V}$			
$V_{HC} = V_{CC} - 0.2\text{V}$			

SYMBOL	PARAMETER	TEST CONDITIONS ⁽¹⁾	MIN.	TYP. ⁽²⁾	MAX.	UNIT	
V_{IH}	Input HIGH Level	Guaranteed Logic High Level	2.0	—	—	V	
V_{IL}	Input LOW Level	Guaranteed Logic Low Level	—	—	0.8	V	
I_{IH}	Input HIGH Current	$V_{CC} = \text{Max.}, V_{IN} = V_{CC}$	—	—	5	μA	
I_{IL}	Input LOW Current	$V_{CC} = \text{Max.}, V_{IN} = \text{GND}$	—	—	-5	μA	
I_{SC}	Short Circuit Current	$V_{CC} = \text{Max.}$ ⁽³⁾	-60	-120	—	mA	
V_{OH}	Output HIGH Voltage	$V_{CC} = 3\text{V}, V_{IN} = V_{LC}$ or $V_{HC}, I_{OH} = -32\mu\text{A}$	V_{HC}	V_{CC}	—	V	
		$V_{CC} = \text{Min.}, V_{IN} = V_{IH}$ or V_{IL}	$I_{OH} = -300\mu\text{A}$	V_{HC}	V_{CC}		—
			$I_{OH} = -12\text{mA MIL.}$	2.4	4.3		—
V_{OL}	Output LOW Voltage	$V_{CC} = 3\text{V}, V_{IN} = V_{LC}$ or $V_{HC}, I_{OL} = 300\mu\text{A}$	—	GND	V_{LC}	V	
		$V_{CC} = \text{Min.}, V_{IN} = V_{IH}$ or V_{IL}	$I_{OL} = 300\mu\text{A}$	—	GND		V_{LC}
			$I_{OL} = 14\text{mA MIL.}$	—	—		0.4
			$I_{OL} = 24\text{mA COM'L.}$	—	—		0.5

NOTES:

- For conditions shown as max. or min., use appropriate value specified under Electrical Characteristics for the applicable device type.
- Typical values are at $V_{CC} = 5.0\text{V}, +25^\circ\text{C}$ ambient and maximum loading.
- Not more than one output should be shorted at one time. Duration of the short circuit test should not exceed one second.

POWER SUPPLY CHARACTERISTICS

$V_{LC} = 0.2V$; $V_{HC} = V_{CC} - 0.2V$

SYMBOL	PARAMETER	TEST CONDITIONS ⁽¹⁾		MIN.	TYP. ⁽²⁾	MAX.	UNIT
I_{CCQ}	Quiescent Power Supply Current	$V_{CC} = \text{Max.}$ $V_{IN} \geq V_{HC}$; $V_{IN} \leq V_{LC}$ $f_i = 0$		—	0.001	1.5	mA
I_{CCT}	Power Supply Current Per TTL Inputs HIGH	$V_{CC} = \text{Max.}$ $V_{IN} = 3.4V$ ⁽³⁾		—	0.5	1.6	mA
I_{CCD}	Dynamic Power Supply Current	$V_{CC} = \text{Max.}$ Outputs Open One Input Toggling 50% Duty Cycle	$V_{IN} \geq V_{HC}$ $V_{IN} \leq V_{LC}$	—	0.15	0.25	mA/ MHz
I_{CC}	Total Power Supply ⁽⁴⁾ Current	$V_{CC} = \text{Max.}$ Outputs Open $f_i = 1.0\text{MHz}$ 50% Duty Cycle	$V_{IN} \geq V_{HC}$ $V_{IN} \leq V_{LC}$ (AHCT)	—	0.15	1.8	mA
			$V_{IN} = 3.4V$ or $V_{IN} = \text{GND}$	—	0.4	2.6	

NOTES:

- For conditions shown as max. or min., use appropriate value specified under Electrical Characteristics for the applicable device type.
- Typical values are at $V_{CC} = 5.0V$, +25°C ambient and maximum loading.
- Per TTL driven input ($V_{IN} = 3.4V$); all other inputs at V_{CC} or GND.

4. $I_{CC} = I_{\text{QUIESCENT}} + I_{\text{INPUTS}} + I_{\text{DYNAMIC}}$

$I_{CC} = I_{CCQ} + I_{CCT}D_HN_T + I_{CCD}(f_{CP}/2 + f_iN_i)$

I_{CCQ} = Quiescent Current

I_{CCT} = Power Supply Current for a TTL High Input ($V_{IN} = 3.4V$)

D_H = Duty Cycle for TTL Inputs High

N_T = Number of TTL Inputs at D_H

I_{CCD} = Dynamic Current caused by an Input Transition pair (HLH or LHL)

f_{CP} = Clock Frequency for Register Devices (Zero for Non-Register Devices)

f_i = Input Frequency

N_i = Number of Inputs at f_i

All currents are in milliamps and all frequencies are in megahertz.

DEFINITION OF FUNCTIONAL TERMS

PIN NAMES	DESCRIPTION
A_0-A_7	Word A inputs
B_0-B_7	Word B inputs
$I_{A=B}$	Expansion or Enable Input (Active LOW)
$O_{A=B}$	Identity Output (Active Low)

TRUTH TABLE

INPUTS		OUTPUT
$\bar{I}_{A=B}$	A, B	$\bar{O}_{A=B}$
L	A = B*	L
L	A ≠ B	H
H	A = B*	H
H	A ≠ B	L

H = HIGH Voltage Level
L = LOW Voltage Level
* $A_0 = B_0$, $A_1 = B_1$, $A_2 = B_2$, etc.

SWITCHING CHARACTERISTICS OVER OPERATING RANGE

SYMBOL	PARAMETER	CONDITION	TYPICAL	COMMERCIAL		MILITARY		UNITS
				MIN.	MAX.	MIN.	MAX.	
t_{PLH} t_{PHL}	Propagation Delay A_N or B_N to $\bar{O}_{A=B}$	$C_L = 50 \text{ pf}$ $R_L = 500 \Omega$	9.0	—	13.0	—	17.0	ns
t_{PLH} t_{PHL}	Propagation Delay $I_{A=B}$ to $\bar{O}_{A=B}$							

