



HIGH-SPEED 3.3V 32K x 18 SYNCHRONOUS PIPELINED DUAL-PORT STATIC RAM

IDT70V9379L
OBSOLETE PART

Features:

- ♦ True Dual-Ported memory cells which allow simultaneous access of the same memory location
- ♦ High-speed clock to data access
 - Commercial: 7.5/9/12ns (max.)
- ♦ Low-power operation
 - IDT70V9379L
 - Active: 500mW (typ.)
 - Standby: 1.5mW (typ.)
- ♦ Flow-Through or Pipelined output mode on either port via the FT/PIPE pins
- ♦ Counter enable and reset features
- ♦ Dual chip enables allow for depth expansion without additional logic
- ♦ Full synchronous operation on both ports
 - 4ns setup to clock and 0ns hold on all control, data, and address inputs
 - Data input, address, and control registers
 - Fast 7.5ns clock to data out in the Pipelined output mode
 - Self-timed write allows fast cycle time
 - 12ns cycle time, 83MHz operation in Pipelined output mode
- ♦ Separate upper-byte and lower-byte controls for multiplexed bus and bus matching compatibility
- ♦ LVTTTL-compatible, single 3.3V ($\pm 0.3V$) power supply
- ♦ Industrial temperature range ($-40^{\circ}C$ to $+85^{\circ}C$) is available for selected speeds
- ♦ Available in a 128-pin Thin Quad Flatpack (TOFP)

Functional Block Diagram

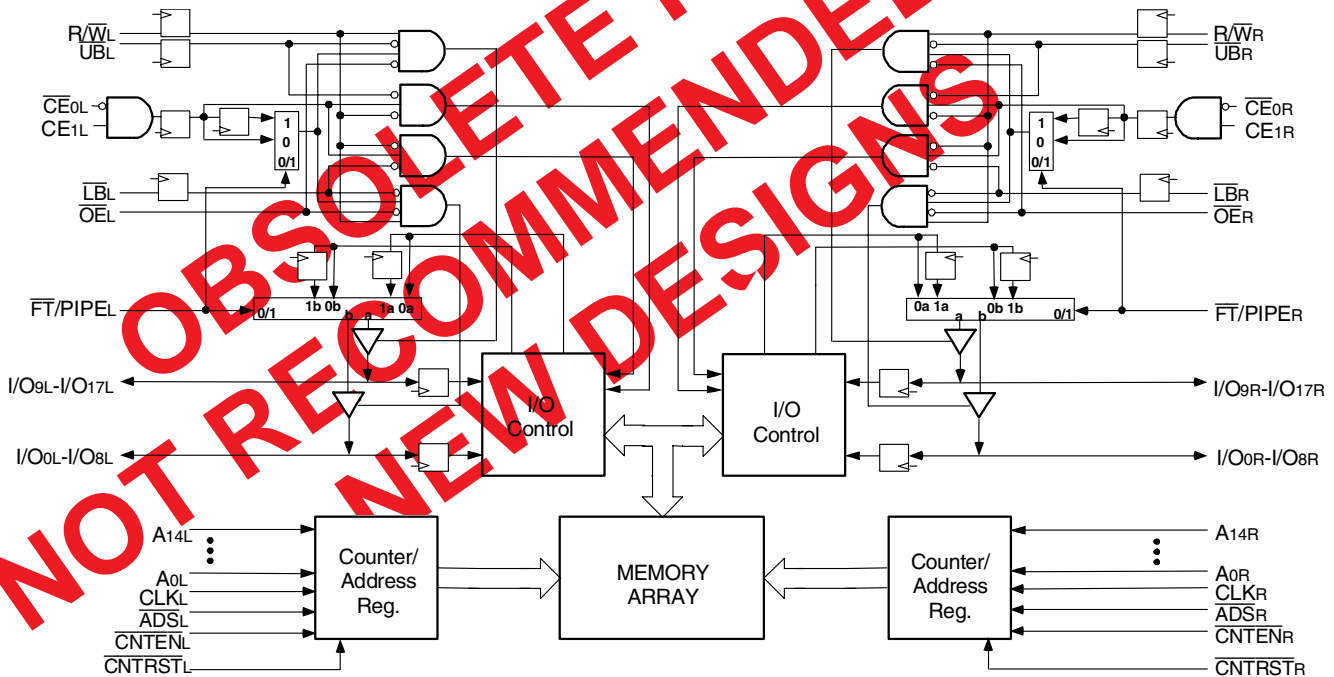

4857 drw 01

JANUARY 2009

Description:

The IDT70V9379 is a high-speed 32K x 18 bit synchronous Dual-Port RAM. The memory array utilizes Dual-Port memory cells to allow simultaneous access of any address from both ports. Registers on control, data, and address inputs provide minimal setup and hold times. The timing latitude provided by this approach allows systems to be designed with very short cycle times.

With an input data register, the IDT70V9379 has been optimized for applications having unidirectional or bidirectional data flow in bursts. An automatic power down feature, controlled by $\overline{CE0}$ and $CE1$, permits the on-chip circuitry of each port to enter a very low standby power mode. Fabricated using IDT's CMOS high-performance technology, these devices typically operate on only 500mW of power.

Pin Configuration^(1,2,3)

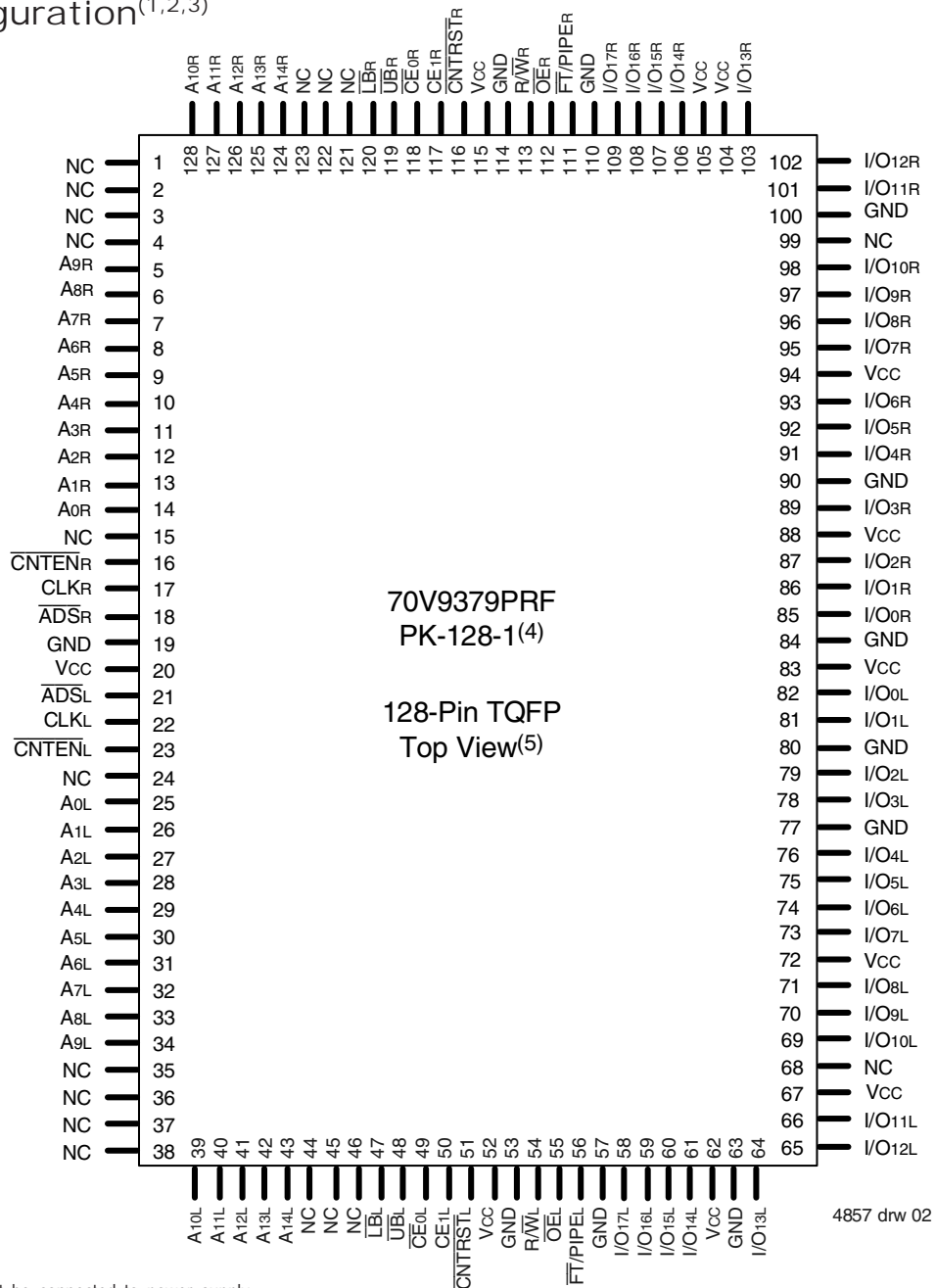

NOTES:

1. All Vcc pins must be connected to power supply.
2. All GND pins must be connected to ground.
3. Package body is approximately 14mm x 20mm x 1.4mm.
4. This package code is used to reference the package diagram.
5. This text does not indicate orientation of the actual part-marking.

Pin Names

Left Port	Right Port	Names
\overline{CE}_{0L} , CE1L	\overline{CE}_{0R} , CE1R	Chip Enables
$\overline{R}/\overline{W}_L$	$\overline{R}/\overline{W}_R$	Read/Write Enable
\overline{OE}_L	\overline{OE}_R	Output Enable
A0L - A14L	A0R - A14R	Address
I/O0L - I/O17L	I/O0R - I/O17R	Data Input/Output
CLKL	CLKR	Clock
\overline{UB}_L	\overline{UB}_R	Upper Byte Select
\overline{LB}_L	\overline{LB}_R	Lower Byte Select
\overline{ADS}_L	\overline{ADS}_R	Address Strobe Enable
\overline{CNTEN}_L	\overline{CNTEN}_R	Counter Enable
\overline{CNRST}_L	\overline{CNRST}_R	Counter Reset
$\overline{FT}/\overline{PIPEL}$	$\overline{FT}/\overline{PIPER}$	Flow-Through / Pipeline
VCC		Power
GND		Ground

4857 tbl 01

Truth Table I—Read/Write and Enable Control^(1,2,3)

\overline{OE}	CLK	\overline{CE}_0	CE1	\overline{UB}	\overline{LB}	$\overline{R}/\overline{W}$	Upper Byte I/O ₉₋₁₇	Lower Byte I/O ₀₋₈	MODE
X	↑	H	X	X	X	X	High-Z	High-Z	Deselected—Power Down
X	↑	X	L	X	X	X	High-Z	High-Z	Deselected—Power Down
X	↑	L	H	H	H	X	High-Z	High-Z	Both Bytes Deselected
X	↑	L	H	L	H	L	DATA _{IN}	High-Z	Write to Upper Byte Only
X	↑	L	H	H	L	L	High-Z	DATA _{IN}	Write to Lower Byte Only
X	↑	L	H	L	L	L	DATA _{IN}	DATA _{IN}	Write to Both Bytes
L	↑	L	H	L	H	H	DATA _{OUT}	High-Z	Read Upper Byte Only
L	↑	L	H	H	L	H	High-Z	DATA _{OUT}	Read Lower Byte Only
L	↑	L	H	L	L	H	DATA _{OUT}	DATA _{OUT}	Read Both Bytes
H	X	L	H	L	L	X	High-Z	High-Z	Outputs Disabled

4857 tbl 02

NOTES:

- "H" = V_{IH}, "L" = V_{IL}, "X" = Don't Care.
- \overline{ADS} , \overline{CNTEN} , \overline{CNRST} = X.
- \overline{OE} is an asynchronous input signal.

Truth Table II—Address Counter Control^(1,2,6)

Address	Previous Address	Addr Used	CLK	$\overline{\text{ADS}}$	$\overline{\text{CNTEN}}$	$\overline{\text{CNRST}}$	I/O ⁽³⁾	MODE
X	X	0	↑	X	X	L	Dvo(0)	Counter Reset to Address 0
An	X	An	↑	L ⁽⁴⁾	X	H	Dvo(n)	External Address Loaded into Counter
An	Ap	Ap	↑	H	H	H	Dvo(p)	External Address Blocked—Counter disabled (Ap reused)
X	Ap	Ap + 1	↑	H	L ⁽⁵⁾	H	Dvo(p+1)	Counter Enabled—Internal Address generation

NOTES:

- "H" = V_{IH}, "L" = V_{IL}, "X" = Don't Care.
- $\overline{\text{CE0}}$, $\overline{\text{LB}}$, $\overline{\text{UB}}$, and $\overline{\text{OE}}$ = V_{IL}; CE₁ and R/W = V_{IH}.
- Outputs configured in Flow-Through Output mode; if outputs are in Pipelined mode the data out will be delayed by one cycle.
- $\overline{\text{ADS}}$ is independent of all other signals including $\overline{\text{CE0}}$, CE₁, $\overline{\text{UB}}$ and $\overline{\text{LB}}$.
- The address counter advances if $\overline{\text{CNTEN}}$ = V_{IL} on the rising edge of CLK, regardless of all other signals including $\overline{\text{CE0}}$, CE₁, $\overline{\text{UB}}$ and $\overline{\text{LB}}$.
- While an external address is being loaded ($\overline{\text{ADS}}$ = V_{IL}), R/W = V_{IH} is recommended to ensure data is not written arbitrarily.

4857 tbl 03

Recommended Operating Temperature and Supply Voltage⁽¹⁾

Grade	Ambient Temperature ⁽²⁾	GND	Vcc
Commercial	0°C to +70°C	0V	3.3V ± 0.3V
Industrial	-40°C to +85°C	0V	3.3V ± 0.3V

4857 tbl 04

NOTES:

- Industrial temperature: for specific speeds, packages and powers contact your sales office.
- This is the parameter T_A. This is the "instant on" case temperature.

Recommended DC Operating Conditions

Symbol	Parameter	Min.	Typ.	Max.	Unit
Vcc	Supply Voltage	3.0	3.3	3.6	V
GND	Ground	0	0	0	V
V _{IH}	Input High Voltage	2.0V	—	Vcc+0.3V ⁽²⁾	V
V _{IL}	Input Low Voltage	-0.3 ⁽¹⁾	—	0.8	V

4857 tbl 05

NOTES:

- V_{IL} ≥ -1.5V for pulse width less than 10 ns.
- V_{TERM} must not exceed Vcc +0.3V.

Absolute Maximum Ratings⁽¹⁾

Symbol	Rating	Commercial & Industrial	Unit
V _{TERM} ⁽²⁾	Terminal Voltage with Respect to GND	-0.5 to +4.6	V
T _{BIAS}	Temperature Under Bias	-55 to +125	°C
T _{STG}	Storage Temperature	-55 to +150	°C
I _{OUT}	DC Output Current	50	mA

4857 tbl 06

NOTES:

- Stresses greater than those listed under ABSOLUTE MAXIMUM RATINGS may cause permanent damage to the device. This is a stress rating only and functional operation of the device at these or any other conditions above those indicated in the operational sections of this specification is not implied. Exposure to absolute maximum rating conditions for extended periods may affect reliability.
- V_{TERM} must not exceed Vcc +0.3V for more than 25% of the cycle time or 10ns maximum, and is limited to ≤ 20mA for the period of V_{TERM} ≥ Vcc + 0.3V.

Capacitance⁽¹⁾(T_A = +25°C, f = 1.0MHz)

Symbol	Parameter	Conditions ⁽²⁾	Max.	Unit
C _{IN}	Input Capacitance	V _{IN} = 3dV	9	pF
C _{OUT} ⁽³⁾	Output Capacitance	V _{OUT} = 3dV	10	pF

4857 tbl 07

NOTES:

- These parameters are determined by device characterization, but are not production tested.
- 3dV references the interpolated capacitance when the input and output switch from 0V to 3V or from 3V to 0V.
- C_{OUT} also references C_{I/O}.

DC Electrical Characteristics Over the Operating Temperature and Supply Voltage Range ($V_{CC} = 3.3V \pm 0.3V$)

Symbol	Parameter	Test Conditions	70V9379L		Unit
			Min.	Max.	
$ I_{L} $	Input Leakage Current ⁽¹⁾	$V_{CC} = 3.6V, V_{IN} = 0V \text{ to } V_{CC}$	—	5	μA
$ I_{O} $	Output Leakage Current	$\overline{CE} = V_{IH} \text{ or } CE_{1X} = V_{IL}, V_{OUT} = 0V \text{ to } V_{CC}$	—	5	μA
V_{OL}	Output Low Voltage	$I_{OL} = +4mA$	—	0.4	V
V_{OH}	Output High Voltage	$I_{OH} = -4mA$	2.4	—	V

NOTE:

- At $V_{CC} \leq 2.0V$ input leakages are undefined.

4857 tbl 08

DC Electrical Characteristics Over the Operating Temperature Supply Voltage Range^(3,6) ($V_{CC} = 3.3V \pm 0.3V$)

Symbol	Parameter	Test Condition	Version	70V9379L7 Com'l Only		70V9379L9 Com'l Only		70V9379L12 Com'l Only		Unit
				Typ. ⁽⁴⁾	Max.	Typ. ⁽⁴⁾	Max.	Typ. ⁽⁴⁾	Max.	
I _{CC}	Dynamic Operating Current (Both Ports Active)	\overline{CE}_L and $\overline{CE}_R = V_{IL}$, Outputs Disabled, $f = f_{MAX}^{(1)}$	COM'L L	200	310	180	260	150	230	mA
			IND L	—	—	—	—	—	—	
ISB1	Standby Current (Both Ports - TTL Level Inputs)	$\overline{CE}_L = \overline{CE}_R = V_{IH}$ $f = f_{MAX}^{(1)}$	COM'L L	65	130	50	100	40	80	mA
			IND L	—	—	—	—	—	—	
ISB2	Standby Current (One Port - TTL Level Inputs)	$\overline{CE}_A^* = V_{IL}$ and $\overline{CE}_B^* = V_{IH}^{(5)}$ Active Port Outputs Disabled, $f = f_{MAX}^{(1)}$	COM'L L	140	245	110	190	100	175	mA
			IND L	—	—	—	—	—	—	
ISB3	Full Standby Current (Both Ports - CMOS Level Inputs)	Both Ports \overline{CE}_L and $\overline{CE}_R \geq V_{CC} - 0.2V$, $V_{IN} \geq V_{CC} - 0.2V$ or $V_{IN} \leq 0.2V, f = 0^{(2)}$	COM'L L	0.4	3.0	0.4	3.0	0.4	3.0	mA
			IND L	—	—	—	—	—	—	
ISB4	Full Standby Current (One Port - CMOS Level Inputs)	$\overline{CE}_A^* \leq 0.2V$ and $\overline{CE}_B^* \geq V_{CC} - 0.2V^{(6)}$ $V_{IN} \geq V_{CC} - 0.2V$ or $V_{IN} \leq 0.2V$, Active Port, Outputs Disabled, $f = f_{MAX}^{(1)}$	COM'L L	130	235	100	180	90	165	mA
			IND L	—	—	—	—	—	—	

NOTES:

- At $f = f_{MAX}$, address and control lines (except Output Enable) are cycling at the maximum frequency clock cycle of $1/t_{cvc}$, using "AC TEST CONDITIONS" at input levels of GND to 3V.
- $f = 0$ means no address, clock, or control lines change. Applies only to input at CMOS level standby.
- Port "A" may be either left or right port. Port "B" is the opposite from port "A".
- $V_{CC} = 3.3V, T_A = 25^\circ C$ for Typ, and are not production tested. $I_{CC}(f=0) = 90mA$ (Typ).
- $\overline{CE}_X = V_{IL}$ means $\overline{CE}_{0X} = V_{IL}$ and $CE_{1X} = V_{IH}$
 $\overline{CE}_X = V_{IH}$ means $\overline{CE}_{0X} = V_{IH}$ or $CE_{1X} = V_{IL}$
 $\overline{CE}_X \leq 0.2V$ means $\overline{CE}_{0X} \leq 0.2V$ and $CE_{1X} \geq V_{CC} - 0.2V$
 $\overline{CE}_X \geq V_{CC} - 0.2V$ means $\overline{CE}_{0X} \geq V_{CC} - 0.2V$ or $CE_{1X} \leq 0.2V$
 "X" represents "L" for left port or "R" for right port.
- Industrial temperature: for specific speeds, packages and powers contact your sales office.

4857 tbl 09

AC Test Conditions

Input Pulse Levels	GND to 3.0V
Input Rise/Fall Times	3ns Max.
Input Timing Reference Levels	1.5V
Output Reference Levels	1.5V
Output Load	Figures 1, 2, and 3

4857 tbl 10

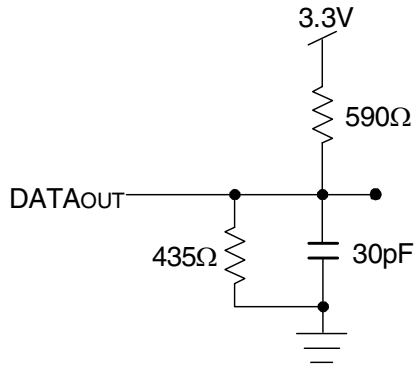

4857 drw 03

Figure 1. AC Output Test load.

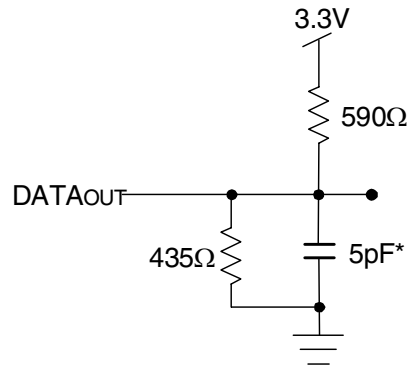

4857 drw 04

Figure 2. Output Test Load
(For tckLZ, tckHZ, toLZ, and toHZ).
*Including scope and jig.

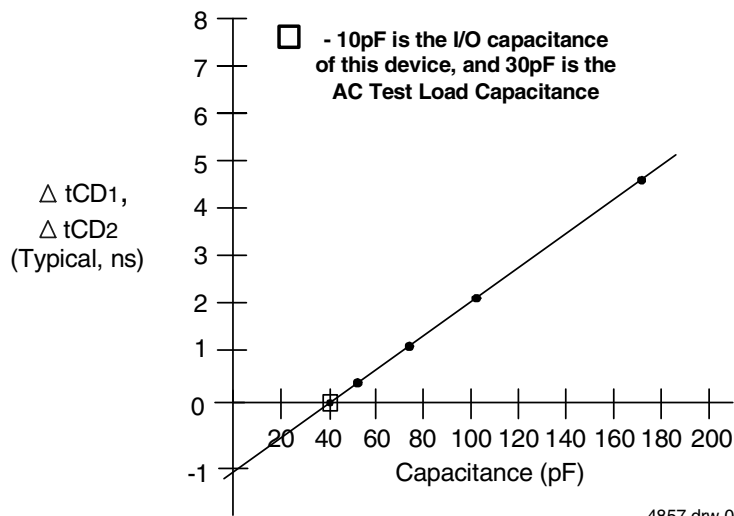

4857 drw 05

Figure 3. Typical Output Derating (Lumped Capacitive Load).

AC Electrical Characteristics Over the Operating Temperature Range (Read and Write Cycle Timing)^(3,4) ($V_{CC} = 3.3V \pm 0.3V$, $T_A = 0^\circ C$ to $+70^\circ C$)

Symbol	Parameter	70V9379L7 Com'1 Only		70V9379L9 Com'1 Only		70V9379L12 Com'1 Only		Unit
		Min.	Max.	Min.	Max.	Min.	Max.	
t _{CYC1}	Clock Cycle Time (Flow-Through) ⁽²⁾	22	—	25	—	30	—	ns
t _{CYC2}	Clock Cycle Time (Pipelined) ⁽²⁾	12	—	15	—	20	—	ns
t _{CH1}	Clock High Time (Flow-Through) ⁽²⁾	7.5	—	12	—	12	—	ns
t _{CL1}	Clock Low Time (Flow-Through) ⁽²⁾	7.5	—	12	—	12	—	ns
t _{CH2}	Clock High Time (Pipelined) ⁽²⁾	5	—	6	—	8	—	ns
t _{CL2}	Clock Low Time (Pipelined) ⁽²⁾	5	—	6	—	8	—	ns
t _r	Clock Rise Time	—	3	—	3	—	3	ns
t _f	Clock Fall Time	—	3	—	3	—	3	ns
t _{SA}	Address Setup Time	4	—	4	—	4	—	ns
t _{HA}	Address Hold Time	0	—	1	—	1	—	ns
t _{SC}	Chip Enable Setup Time	4	—	4	—	4	—	ns
t _{HC}	Chip Enable Hold Time	0	—	1	—	1	—	ns
t _{SW}	R/W Setup Time	4	—	4	—	4	—	ns
t _{HW}	R/W Hold Time	0	—	1	—	1	—	ns
t _{SD}	Input Data Setup Time	4	—	4	—	4	—	ns
t _{HD}	Input Data Hold Time	0	—	1	—	1	—	ns
t _{SAD}	\overline{ADS} Setup Time	4	—	4	—	4	—	ns
t _{HAD}	\overline{ADS} Hold Time	0	—	1	—	1	—	ns
t _{SCN}	\overline{CNTEN} Setup Time	4	—	4	—	4	—	ns
t _{HCN}	\overline{CNTEN} Hold Time	0	—	1	—	1	—	ns
t _{SRST}	\overline{CNRST} Setup Time	4	—	4	—	4	—	ns
t _{HRST}	\overline{CNRST} Hold Time	0	—	1	—	1	—	ns
t _{OE}	Output Enable to Data Valid	—	9	—	12	—	12	ns
t _{OLZ}	Output Enable to Output Low-Z ⁽¹⁾	2	—	2	—	2	—	ns
t _{OHZ}	Output Enable to Output High-Z ⁽¹⁾	1	7	1	7	1	7	ns
t _{CD1}	Clock to Data Valid (Flow-Through) ⁽²⁾	—	18	—	20	—	25	ns
t _{CD2}	Clock to Data Valid (Pipelined) ⁽²⁾	—	7.5	—	9	—	12	ns
t _{DC}	Data Output Hold After Clock High	2	—	2	—	2	—	ns
t _{CKHZ}	Clock High to Output High-Z ⁽¹⁾	2	9	2	9	2	9	ns
t _{CKLZ}	Clock High to Output Low-Z ⁽¹⁾	2	—	2	—	2	—	ns
Port-to-Port Delay								
t _{OWDD}	Write Port Clock High to Read Data Delay	—	28	—	35	—	40	ns
t _{CCS}	Clock-to-Clock Setup Time	—	10	—	15	—	15	ns

4857 tbl 11

NOTES:

1. Transition is measured 0mV from Low or High-impedance voltage with the Output Test Load (Figure 2). This parameter is guaranteed by device characterization, but is not production tested.
2. The Pipelined output parameters (t_{CYC2}, t_{CD2}) apply to either or both the Left and Right ports when $\overline{FT}/PIPE = V_{IH}$. Flow-through parameters (t_{CYC1}, t_{CD1}) apply when $\overline{FT}/PIPE = V_{IL}$ for that port.
3. All input signals are synchronous with respect to the clock except for the asynchronous Output Enable (\overline{OE}), $\overline{FT}/PIPE_R$, and $\overline{FT}/PIPE_L$.
4. Industrial temperature: for specific speeds, packages and powers contact your sales office.

Timing Waveform of Read Cycle for Flow-Through Output ($\overline{\text{FT}}/\text{PIPE} \text{ "X" } = \text{VIL}$)^(3,7)

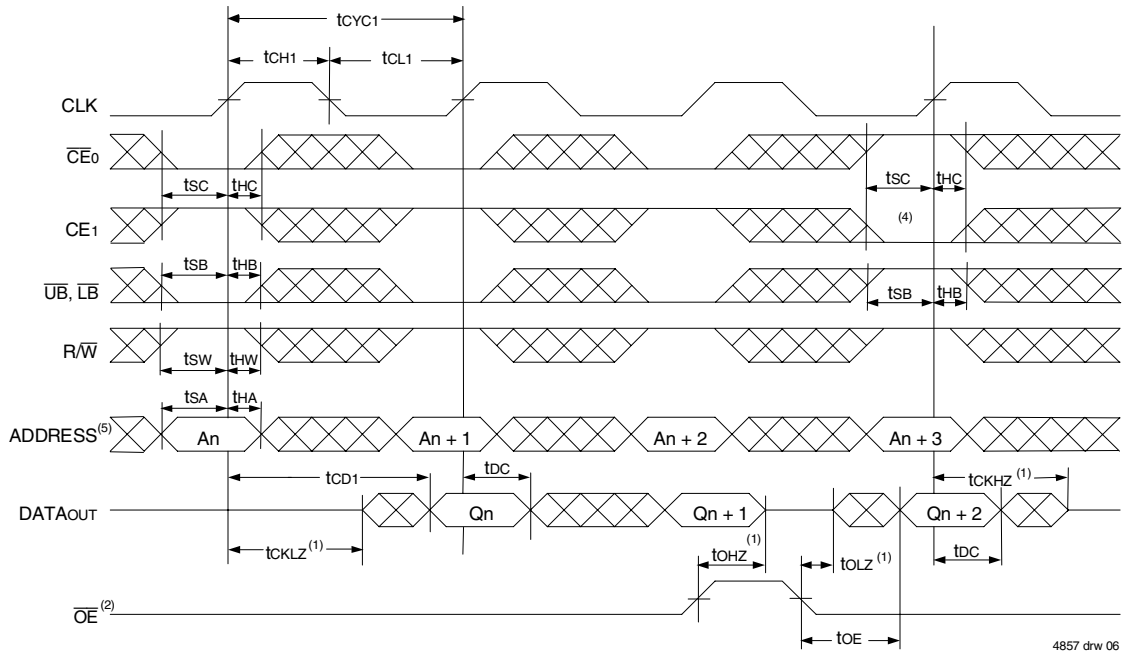

4857 drw 06

Timing Waveform of Read Cycle for Pipelined Operation ($\overline{\text{FT}}/\text{PIPE} \text{ "X" } = \text{VIH}$)^(3,7)

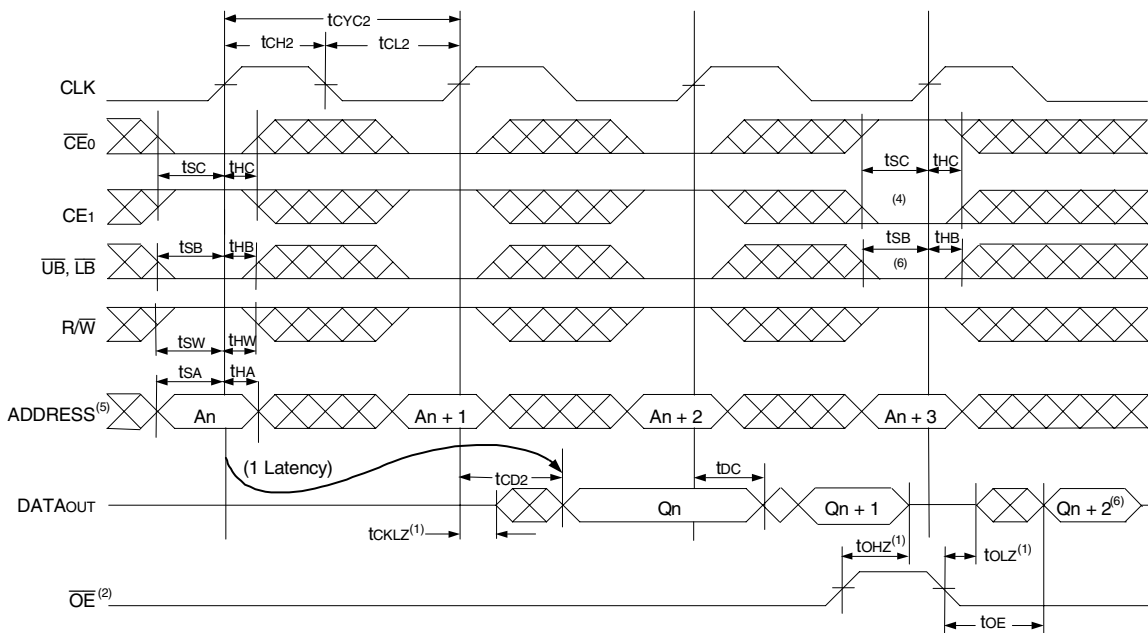

4857 drw 07

NOTES:

1. Transition is measured 0mV from Low or High-impedance voltage with the Output Test Load (Figure 2).
2. $\overline{\text{OE}}$ is asynchronously controlled; all other inputs are synchronous to the rising clock edge.
3. $\overline{\text{ADS}} = \text{VIL}$, $\overline{\text{CNTEN}}$ and $\overline{\text{CNRST}} = \text{VIH}$.
4. The output is disabled (High-Impedance state) by $\overline{\text{CE}}_0 = \text{VIH}$, $\text{CE}_1 = \text{VIL}$, $\overline{\text{UB}} = \text{VIH}$, or $\overline{\text{LB}} = \text{VIH}$ following the next rising edge of the clock. Refer to Truth Table 1.
5. Addresses do not have to be accessed sequentially since $\overline{\text{ADS}} = \text{VIL}$ constantly loads the address on the rising edge of the CLK; numbers are for reference use only.
6. If $\overline{\text{UB}}$ or $\overline{\text{LB}}$ was HIGH, then the Upper Byte and/or Lower Byte of DATAout for Qn + 2 would be disabled (High-Impedance state).
7. "X" here denotes Left or Right port. The diagram is with respect to that port.

Timing Waveform of a Bank Select Pipelined Read^(1,2)

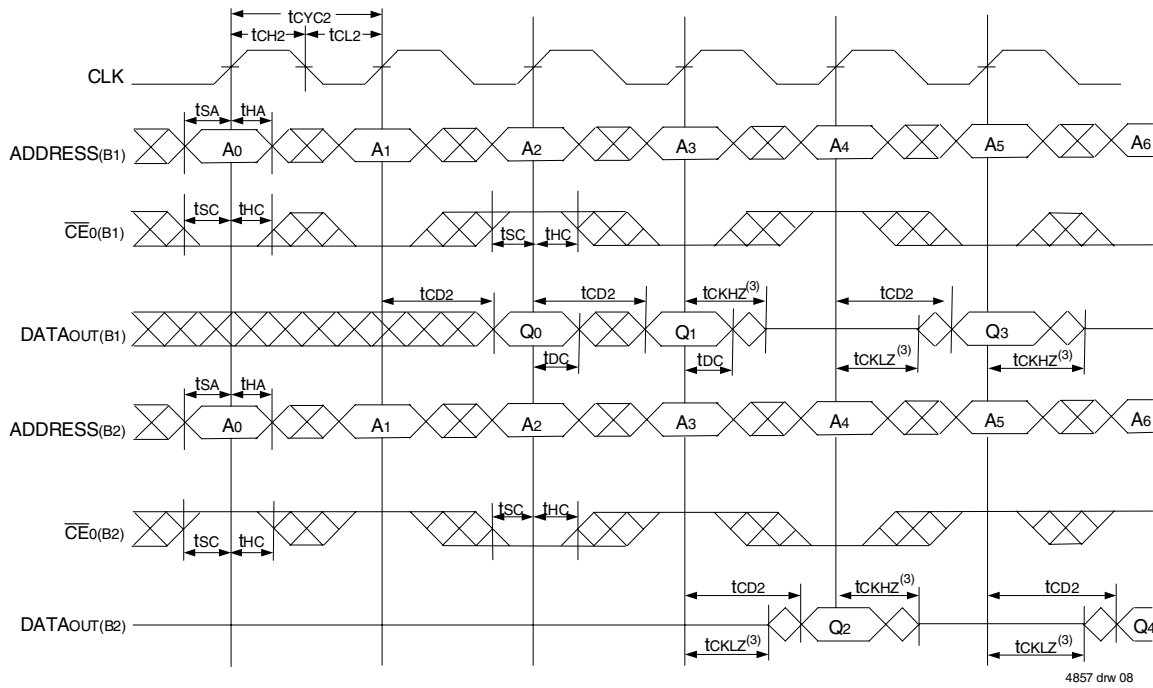

4857 drw 08

Timing Waveform with Port-to-Port Flow-Through Read^(4,5,7)

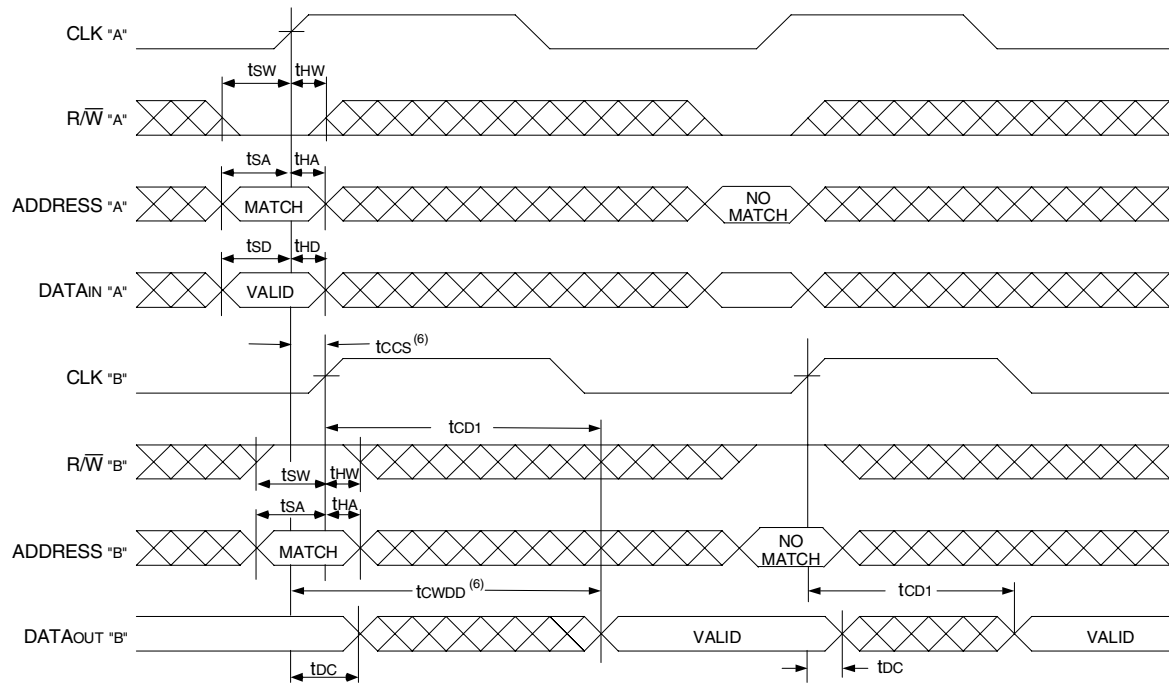

4857 drw 09

NOTES:

1. B1 Represents Bank #1; B2 Represents Bank #2. Each Bank consists of one IDT70V9379 for this waveform, and are setup for depth expansion in this example. ADDRESS_(B1) = ADDRESS_(B2) in this situation.
2. \overline{UB} , \overline{LB} , \overline{OE} , and $\overline{ADS} = V_{IL}$; $CE_{1(B1)}$, $CE_{1(B2)}$, R/\overline{W} , \overline{CNTEN} , and $\overline{CNRST} = V_{IH}$.
3. Transition is measured 0mV from Low or High-impedance voltage with the Output Test Load (Figure 2).
4. \overline{CE}_0 , \overline{UB} , \overline{LB} , and $\overline{ADS} = V_{IL}$; CE_1 , \overline{CNTEN} , and $\overline{CNRST} = V_{IH}$.
5. $\overline{OE} = V_{IL}$ for the Right Port, which is being read from. $\overline{OE} = V_{IH}$ for the Left Port, which is being written to.
6. If $t_{CCS} \leq$ maximum specified, then data from right port READ is not valid until the maximum specified for t_{CWD} . If $t_{CCS} >$ maximum specified, then data from right port READ is not valid until $t_{CCS} + t_{CD1}$. t_{CWD} does not apply in this case.
7. All timing is the same for both Left and Right ports. Port "A" may be either Left or Right port. Port "B" is the opposite from Port "A".

Timing Waveform of Pipelined Read-to-Write-to-Read ($\overline{OE} = V_{IL}$)⁽³⁾

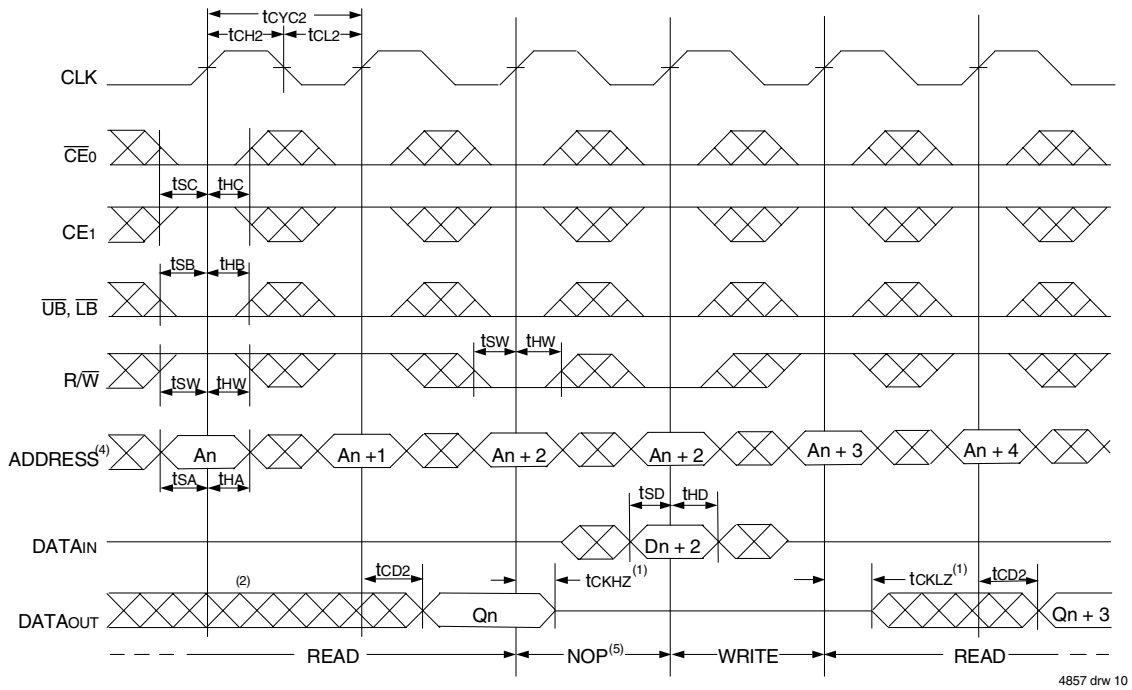

4857 drw 10

Timing Waveform of Pipelined Read-to-Write-to-Read (\overline{OE} Controlled)⁽³⁾

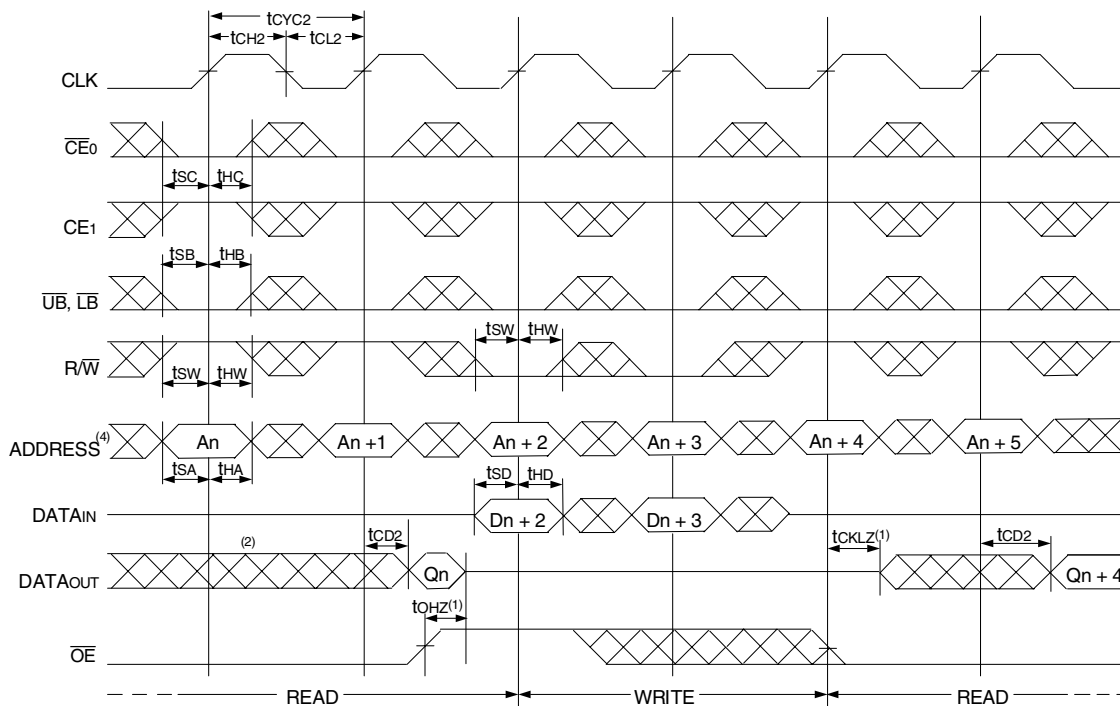

4857 drw 11

NOTES:

1. Transition is measured 0mV from Low or High-impedance voltage with the Output Test Load (Figure 2).
2. Output state (High, Low, or High-impedance) is determined by the previous cycle control signals.
3. \overline{CE}_0 , \overline{UB} , \overline{LB} , and $\overline{ADS} = V_{IL}$; CE_1 , \overline{CNTEN} , and $\overline{CNTRST} = V_{IH}$. "NOP" is "No Operation".
4. Addresses do not have to be accessed sequentially since $\overline{ADS} = V_{IL}$ constantly loads the address on the rising edge of the CLK; numbers are for reference use only.
5. "NOP" is "No Operation." Data in memory at the selected address may be corrupted and should be re-written to guarantee data integrity.

Timing Waveform of Flow-Through Read-to-Write-to-Read ($\overline{OE} = V_{IL}$)⁽³⁾

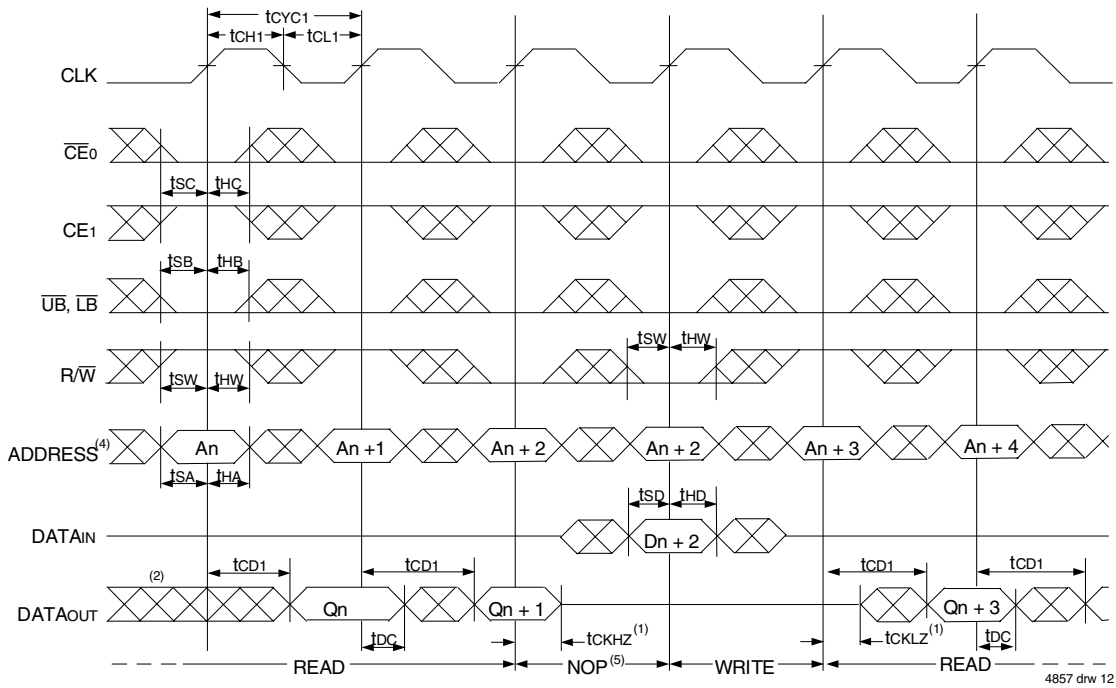

4857 drw 12

Timing Waveform of Flow-Through Read-to-Write-to-Read (\overline{OE} Controlled)⁽³⁾

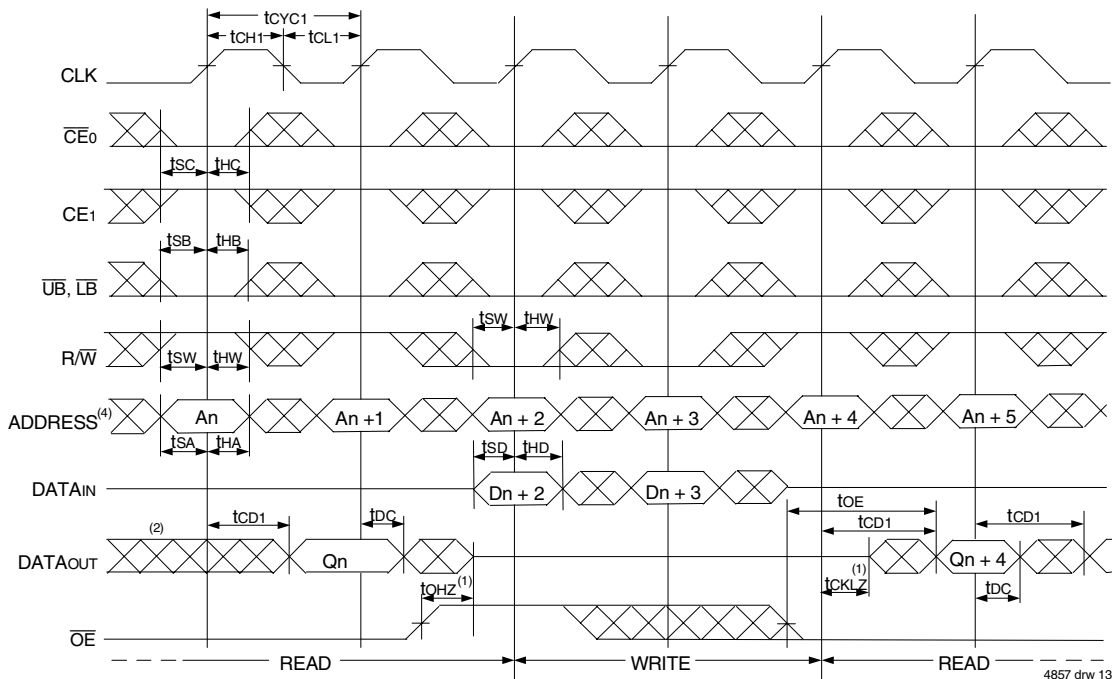

4857 drw 13

NOTES:

1. Transition is measured 0mV from Low or High-impedance voltage with the Output Test Load (Figure 2).
2. Output state (High, Low, or High-impedance) is determined by the previous cycle control signals.
3. $\overline{CE0}$, \overline{UB} , \overline{LB} , and $\overline{ADS} = V_{IL}$; $CE1$, \overline{CNTEN} , and $\overline{CNTRST} = V_{IH}$. "NOP" is "No Operation".
4. Addresses do not have to be accessed sequentially since $\overline{ADS} = V_{IL}$ constantly loads the address on the rising edge of the CLK; numbers are for reference use only.
5. "NOP" is "No Operation." Data in memory at the selected address may be corrupted and should be re-written to guarantee data integrity.

Timing Waveform of Pipelined Read with Address Counter Advance⁽¹⁾

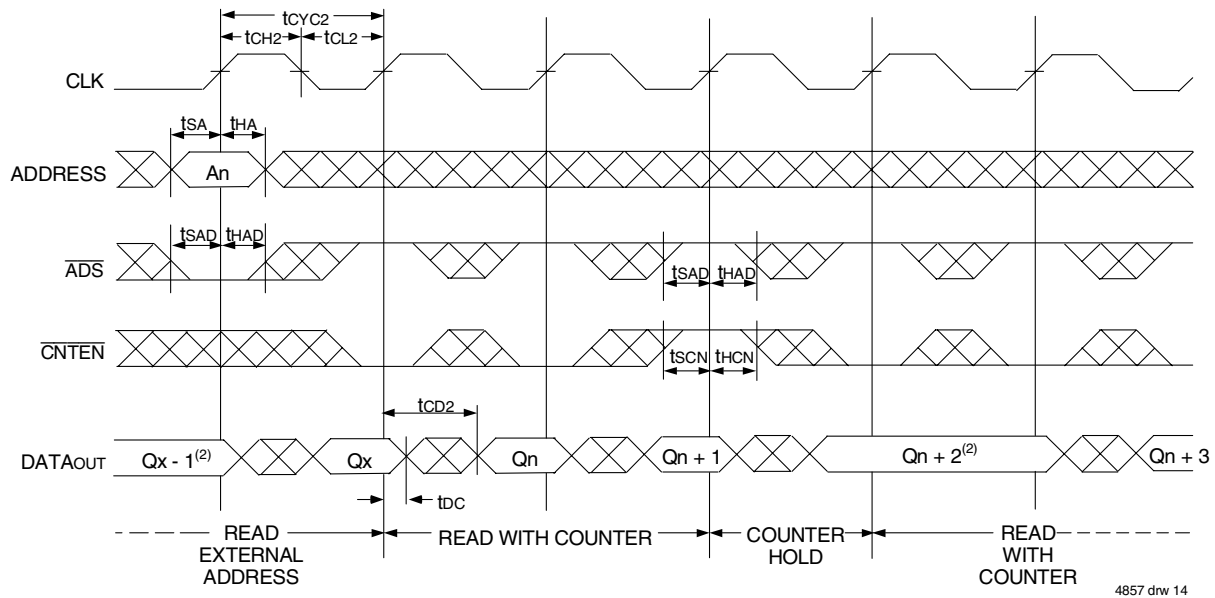

Timing Waveform of Flow-Through Read with Address Counter Advance⁽¹⁾

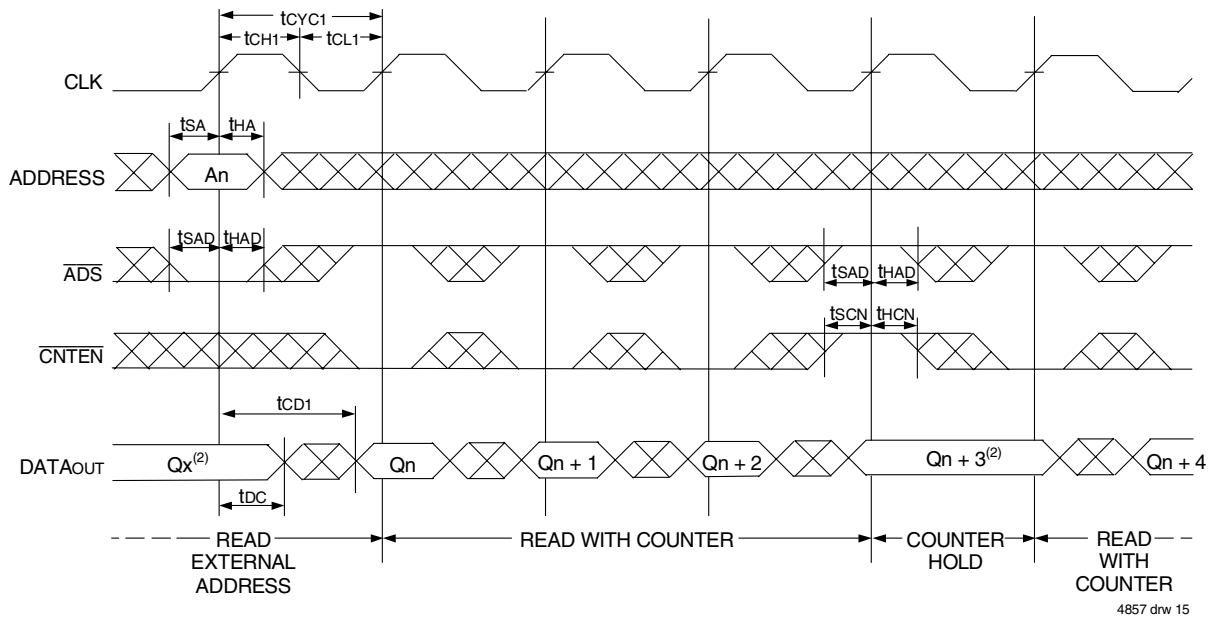

NOTES:

1. \overline{CE}_0 , \overline{OE} , \overline{UB} , and $\overline{LB} = V_{IL}$; CE_1 , \overline{RW} , and $\overline{CNRST} = V_{IH}$.
2. If there is no address change via $ADS = V_{IL}$ (loading a new address) or $\overline{CNTEN} = V_{IL}$ (advancing the address), i.e. $\overline{ADS} = V_{IH}$ and $\overline{CNTEN} = V_{IH}$, then the data output remains constant for subsequent clocks.

Timing Waveform of Write with Address Counter Advance (Flow-Through or Pipelined Outputs)⁽¹⁾

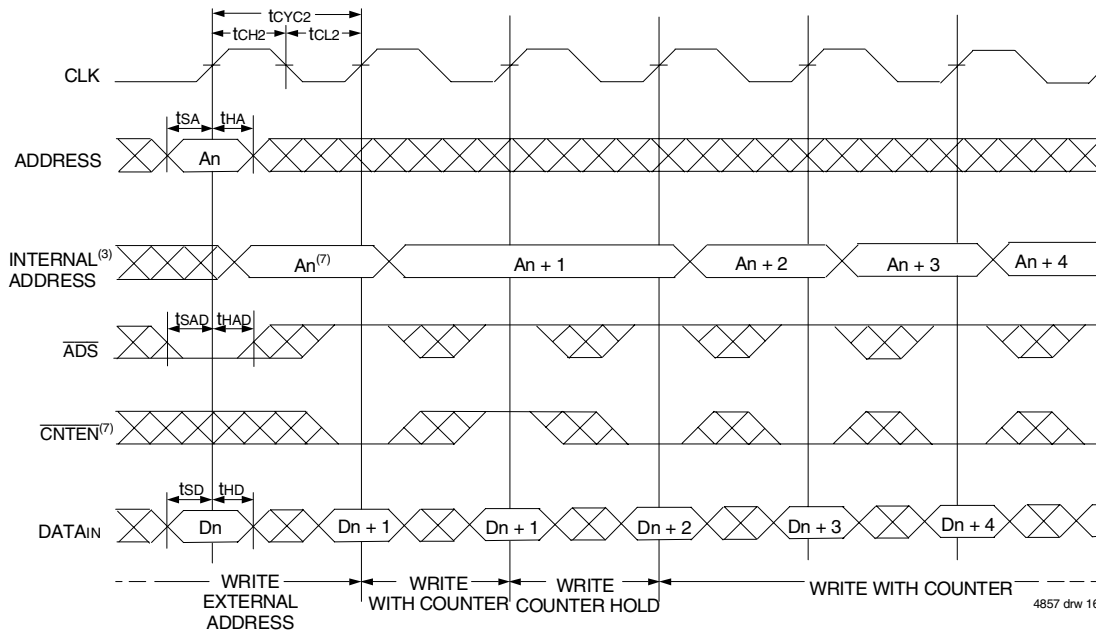

Timing Waveform of Counter Reset (Pipelined Outputs)⁽²⁾

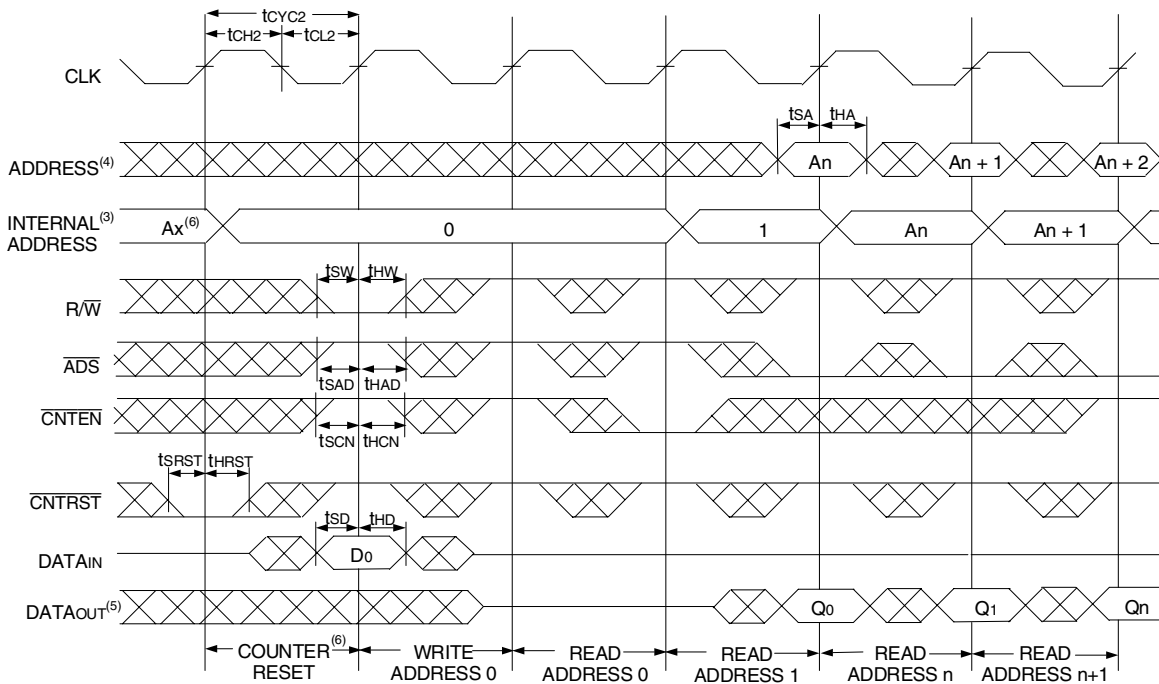

NOTES:

1. \overline{CE}_0 , \overline{UB} , \overline{LB} , and R/\overline{W} = V_{IL} ; CE_1 and \overline{CNTRST} = V_{IH} .
2. \overline{CE}_0 , \overline{UB} , \overline{LB} = V_{IL} ; CE_1 = V_{IH} .
3. The "Internal Address" is equal to the "External Address" when \overline{ADS} = V_{IL} and equals the counter output when \overline{ADS} = V_{IH} .
4. Addresses do not have to be accessed sequentially since \overline{ADS} = V_{IL} constantly loads the address on the rising edge of the CLK; numbers are for reference use only.
5. Output state (High, Low, or High-impedance) is determined by the previous cycle control signals.
6. No dead cycle exists during counter reset. A READ or WRITE cycle may be coincidental with the counter reset cycle. $ADDR_0$ will be accessed. Extra cycles are shown here simply for clarification.
7. \overline{CNTEN} = V_{IL} advances Internal Address from 'An' to 'An + 1'. The transition shown indicates the time required for the counter to advance. The 'An + 1' Address is written to during this cycle.

Functional Description

The IDT70V9379 provides a true synchronous Dual-Port Static RAM interface. Registered inputs provide minimal set-up and hold times on address, data, and all critical control inputs. All internal registers are clocked on the rising edge of the clock signal, however, the self-timed internal write pulse is independent of the LOW to HIGH transition of the clock signal.

An asynchronous output enable is provided to ease asynchronous bus interfacing. Counter enable inputs are also provided to staff the operation of the address counters for fast interleaved memory applications.

$\overline{CE}_0 = V_{IL}$ and $CE_1 = V_{IH}$ for one clock cycle will power down the internal circuitry to reduce static power consumption. Multiple chip enables allow easier banking of multiple IDT70V9379's for depth expansion configurations. When the Pipelined output mode is enabled, two cycles are required with $\overline{CE}_0 = V_{IL}$ and $CE_1 = V_{IH}$ to re-activate the outputs.

Depth and Width Expansion

The IDT70V9379 features dual chip enables (refer to Truth Table I) in order to facilitate rapid and simple depth expansion with no requirements for external logic. Figure 4 illustrates how to control the various chip enables in order to expand two devices in depth.

The IDT70V9379 can also be used in applications requiring expanded width, as indicated in Figure 4. Since the banks are allocated at the discretion of the user, the external controller can be set up to drive the input signals for the various devices as required to allow for 36-bit or wider applications.

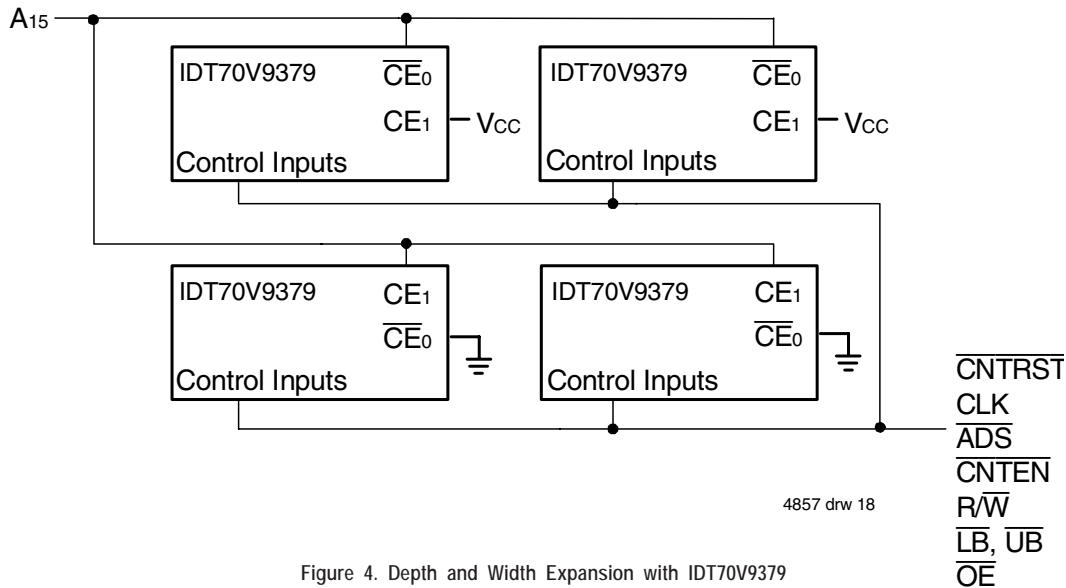
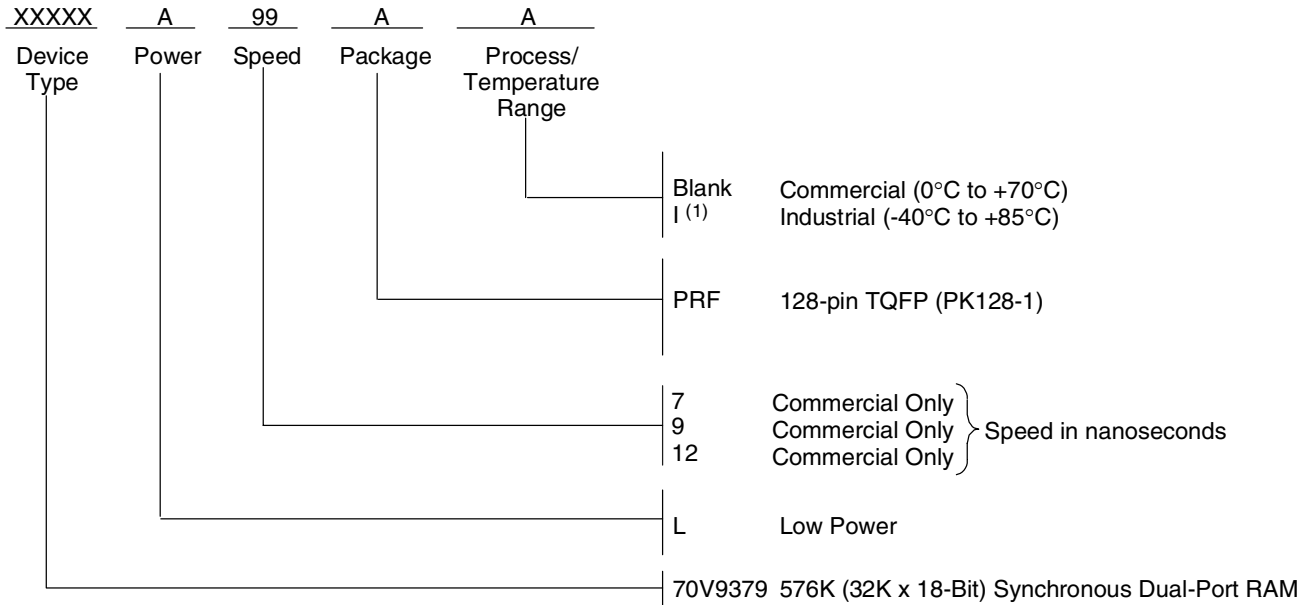

Figure 4. Depth and Width Expansion with IDT70V9379

Ordering Information



4857 drw 19

NOTE:

- Industrial temperature range is available.
For specific speeds, packages and powers contact your sales office.

Datasheet Document History

- 9/30/99: Initial Public Release
- 11/10/99: Replace IDT logo
- 1/17/01: Page 4 Changed information in Truth Table II
Increased storage temperature parameters
Clarified TA parameter
- Page 5 DC Electrical parameters—changed wording from "open" to "disabled"
Changed ±200mV to 0mV in notes
Removed Preliminary status
- 01/29/09: Page 15 Removed "IDT" from orderable part number
- 04/26/09: PDN-F-09-01 issued. See IDT.com for PDN specifics
- 11/20/13: Datasheet changed to Obsolete Status



CORPORATE HEADQUARTERS
 6024 Silver Creek Valley Road
 San Jose, CA 95138

for SALES:
 800-345-7015 or 408-284-8200
 fax: 408-284-2775
 www.idt.com

for Tech Support:
 408-284-2794
 DualPortHelp@idt.com

The IDT logo is a registered trademark of Integrated Device Technology, Inc.