



Integrated Device Technology, Inc.

3.3V CMOS STATIC RAM 4 MEG (512K x 8-BIT)

**ADVANCE
INFORMATION
IDT71V424**

FEATURES:

- 512K x 8 advanced high-speed CMOS Static RAM
- JEDEC Center Power / GND pinout for reduced noise
- Equal access and cycle times
— 12/15/20ns
- Single 3.3V power supply
- One Chip Select plus one Output Enable pin
- Bidirectional data inputs and outputs directly TTL-compatible
- Low power consumption via chip deselect
- Available in 36-pin, 400 mil plastic SOJ package

DESCRIPTION:

The IDT71V424 is a 4,194,304-bit high-speed Static RAM organized as 512K x 8. It is fabricated using IDT's high-performance, high-reliability CMOS technology. This state-of-the-art technology, combined with innovative circuit design techniques, provides a cost-effective solution for high-speed memory needs.

The IDT71V424 has an output enable pin which operates as fast as 6ns, with address access times as fast as 12ns. All bidirectional inputs and outputs of the IDT71V424 are TTL-compatible and operation is from a single 3.3V supply. Fully static asynchronous circuitry is used, requiring no clocks or refresh for operation.

The IDT71V424 is packaged in a 36-pin, 400mil Plastic SOJ.

FUNCTIONAL BLOCK DIAGRAM

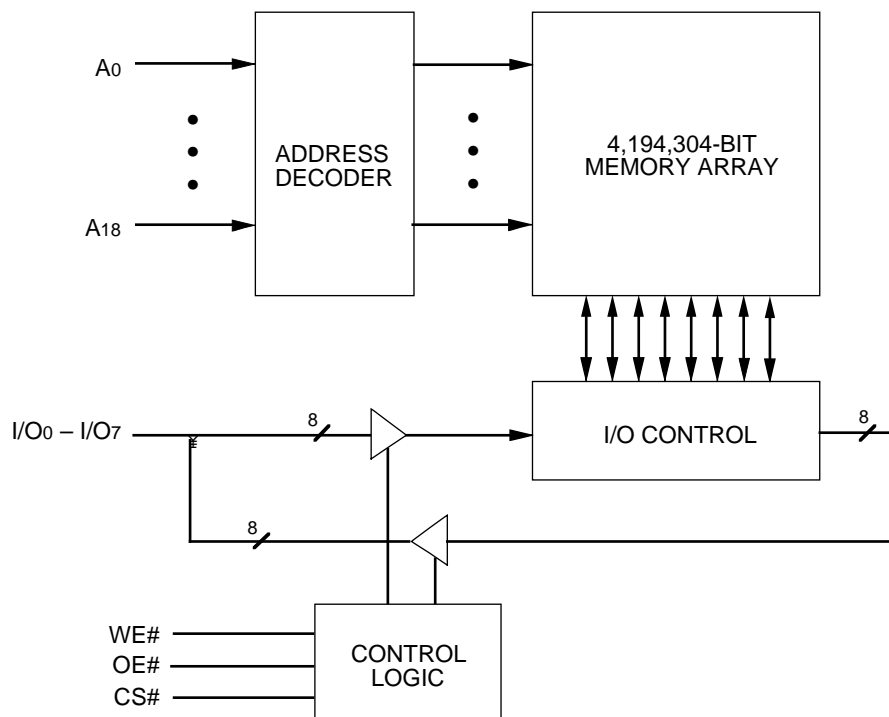

3622 drw 01

The IDT logo is a registered trademark of Integrated Device Technology, Inc.

COMMERCIAL TEMPERATURE RANGE

AUGUST 1996

PIN CONFIGURATION

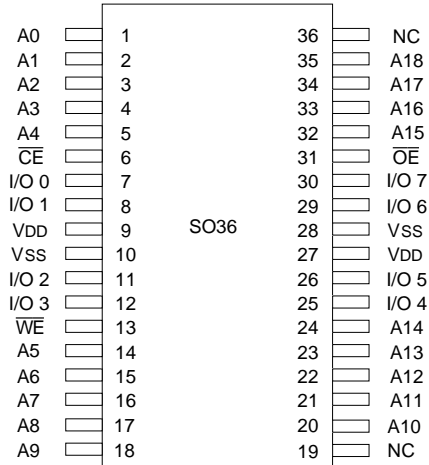

3622 drw 02

**SOJ
TOP VIEW**

PIN DESCRIPTION

A0 – A18	Address Inputs	Input
\overline{CS}	Chip Select	Input
\overline{WE}	Write Enable	Input
\overline{OE}	Output Enable	Input
I/O0 - I/O7	Data Input/Output	I/O
VDD	3.3V Power	Power
VSS	Ground	Gnd

3622 tbl 01

ORDERING INFORMATION

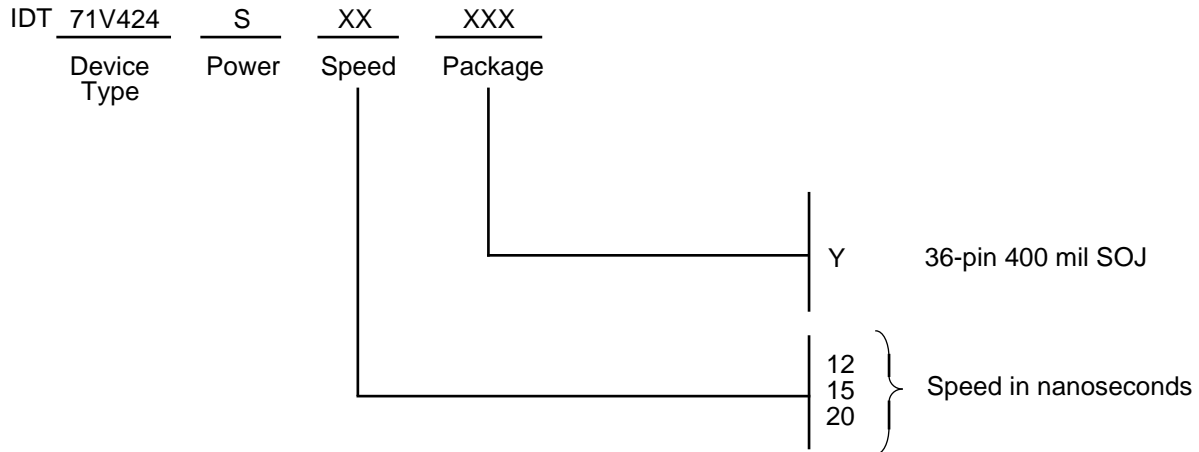

3622 drw 03