



3.3V CMOS 16-BIT EDGE TRIGGERED D-TYPE FLIP- FLOP WITH 3-STATE OUTPUTS, 5 VOLT TOLERANT I/O, BUS-HOLD

IDT74LVCH162374A

FEATURES:

- Typical $t_{SK(0)}$ (Output Skew) < 250ps
- ESD > 2000V per MIL-STD-883, Method 3015; > 200V using machine model (C = 200pF, R = 0)
- 0.635mm pitch SSOP, 0.50mm pitch TSSOP and 0.40mm pitch TVSOP packages
- Extended commercial range of -40°C to +85°C
- $V_{CC} = 3.3V \pm 0.3V$, Normal Range
- $V_{CC} = 2.7V$ to 3.6V, Extended Range
- CMOS power levels (0.4μW typ. static)
- All inputs, outputs and I/O are 5 Volt tolerant
- Supports hot insertion

Drive Features for LVCH162374A:

- Balanced Output Drivers: $\pm 12mA$
- Low switching noise

APPLICATIONS:

- 5V and 3.3V mixed voltage systems
- Data communication and telecommunication systems

DESCRIPTION:

The LVCH162374A 16-bit edge-triggered D-type flip-flop is built using advanced dual metal CMOS technology. This high-speed, low-power register is ideal for use as a buffer register for data synchronization and storage. The output enable (\overline{OE}) and clock (CLK) controls are organized to operate each device as two 8-bit registers or one 16-bit register with common clock. Flow-through organization of signal pins simplifies layout. All inputs are designed with hysteresis for improved noise margin.

All pins of the LVCH162374A can be driven from either 3.3V or 5V devices. This feature allows the use of this device as a translator in a mixed 3.3V/5V supply system.

The LVCH162374A has series resistors in the device output structure which will significantly reduce line noise when used with light loads. This driver has been developed to drive $\pm 12mA$ at the designated thresholds.

The LVCH162374A has "bus-hold" which retains the inputs' last state whenever the input goes to a high impedance. This prevents floating inputs and eliminates the need for pull-up/down resistors.

FUNCTIONAL BLOCK DIAGRAM

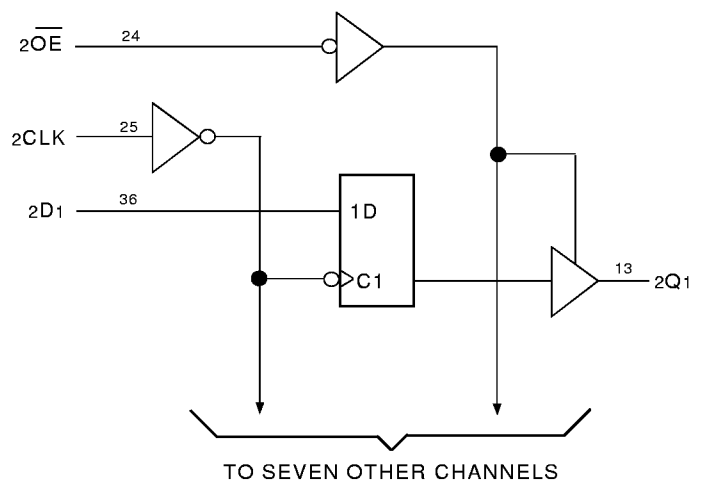
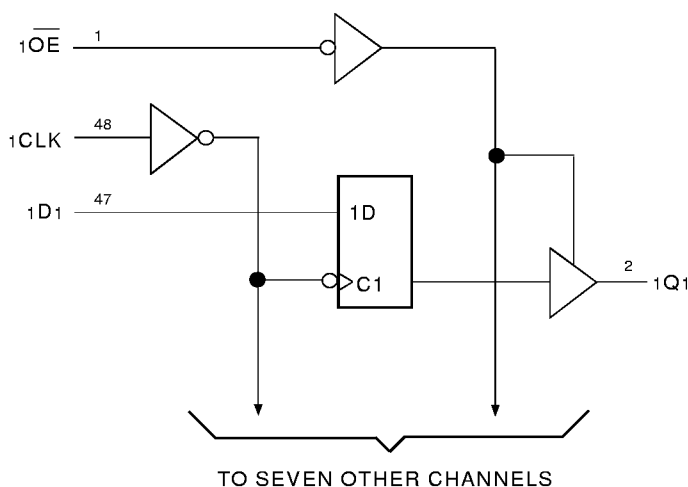

www.DataSheet.in

PIN CONFIGURATION

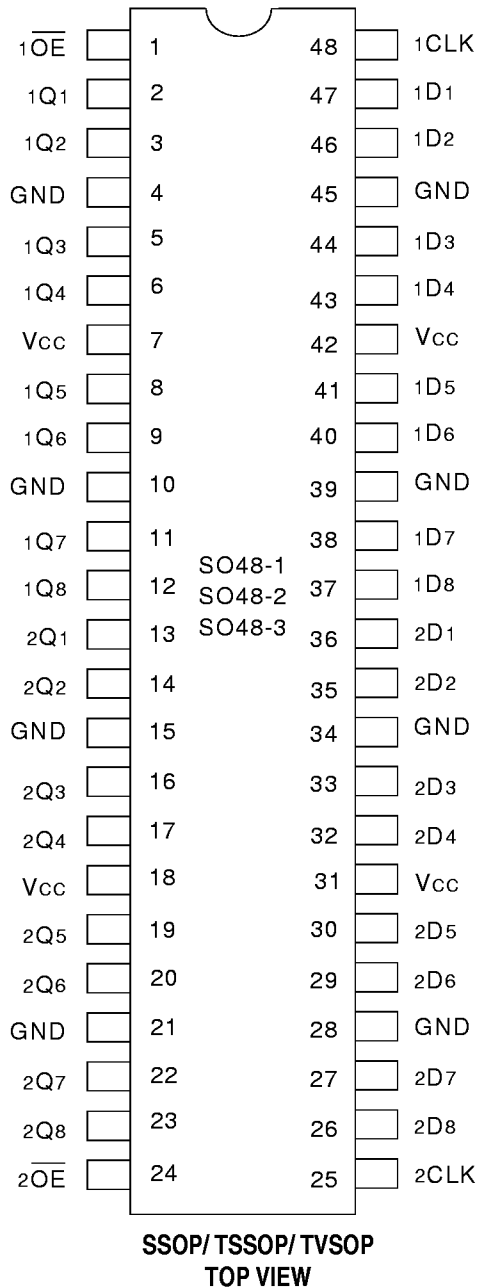

PIN DESCRIPTION

Pin Names	Description
xDx	Data Inputs ⁽¹⁾
xCLK	Clock Inputs
xQx	3-State Outputs
xOE	3-State Output Enable Inputs (Active LOW)

NOTE:

1. These pins have "Bus-hold". All other pins are standard inputs, outputs, or I/Os.

ABSOLUTE MAXIMUM RATINGS (1)

Symbol	Description	Max.	Unit
VTERM ⁽²⁾	Terminal Voltage with Respect to GND	- 0.5 to +6.5	V
VTERM ⁽³⁾	Terminal Voltage with Respect to GND	- 0.5 to +6.5	V
TSTG	Storage Temperature	- 65 to +150	°C
I _{OUT}	DC Output Current	- 50 to +50	mA
I _{IK} I _{OK}	Continuous Clamp Current, V _I < 0 or V _O < 0	- 50	mA
I _{CC} I _{SS}	Continuous Current through each V _{CC} or GND	±100	mA

LVC Link

NOTES:

1. Stresses greater than those listed under ABSOLUTE MAXIMUM RATINGS may cause permanent damage to the device. This is a stress rating only and functional operation of the device at these or any other conditions above those indicated in the operational sections of this specification is not implied. Exposure to absolute maximum rating conditions for extended periods may affect reliability.
2. V_{CC} terminals.
3. All terminals except V_{CC}.

CAPACITANCE (T_A = +25°C, f = 1.0MHz)

Symbol	Parameter ⁽¹⁾	Conditions	Typ.	Max.	Unit
C _{IN}	Input Capacitance	V _{IN} = 0V	4.5	6	pF
C _{OUT}	Output Capacitance	V _{OUT} = 0V	6.5	8	pF
C _{I/O}	I/O Port Capacitance	V _{IN} = 0V	6.5	8	pF

LVC Link

NOTE:

1. As applicable to the device type.

FUNCTION TABLE (each flip-flop) (1)

Inputs			Outputs
xOE	xCLK	xDx	xQx
L	↑	H	H
L	↑	L	L
L	H or L	X	Q ₀
H	X	X	Z

NOTE:

1. H = HIGH Voltage Level
L = LOW Voltage Level
X = Don't Care
Z = High-Impedance
Q₀ = Level of Q before the indicated steady-state input conditions were established.

DC ELECTRICAL CHARACTERISTICS OVER OPERATING RANGE

Following Conditions Apply Unless Otherwise Specified:

Operating Condition: TA = -40°C to +85°C

Symbol	Parameter	Test Conditions		Min.	Typ. ⁽¹⁾	Max.	Unit
V _{IH}	Input HIGH Voltage Level	V _{CC} = 2.3V to 2.7V		1.7	—	—	V
		V _{CC} = 2.7V to 3.6V		2	—	—	
V _{IL}	Input LOW Voltage Level	V _{CC} = 2.3V to 2.7V		—	—	0.7	V
		V _{CC} = 2.7V to 3.6V		—	—	0.8	
I _{IH} I _{IL}	Input Leakage Current	V _{CC} = 3.6V	V _I = 0 to 5.5V	—	—	±5	μA
I _{OZH} I _{OZL}	High Impedance Output Current (3-State Output pins)	V _{CC} = 3.6V	V _O = 0 to 5.5V	—	—	±10	μA
I _{OFF}	Input/Output Power Off Leakage	V _{CC} = 0V, V _{IN} or V _O ≤ 5.5V		—	—	±50	μA
V _{IK}	Clamp Diode Voltage	V _{CC} = 2.3V, I _{IN} = -18mA		—	-0.7	-1.2	V
V _H	Input Hysteresis	V _{CC} = 3.3V		—	100	—	mV
I _{CC1} I _{CC2} I _{CC3}	Quiescent Power Supply Current	V _{CC} = 3.6V	V _{IN} = GND or V _{CC}	—	—	10	μA
			3.6 ≤ V _{IN} ≤ 5.5V ⁽²⁾	—	—	10	
ΔI _{CC}	Quiescent Power Supply Current Variation	One input at V _{CC} - 0.6V other inputs at V _{CC} or GND		—	—	500	μA

LVC Link

NOTES:

1. Typical values are at V_{CC} = 3.3V, +25°C ambient.
2. This applies in the disabled state only.

BUS-HOLD CHARACTERISTICS

Symbol	Parameter ⁽¹⁾	Test Conditions		Min.	Typ. ⁽²⁾	Max.	Unit
I _{BHH} I _{BHL}	Bus-Hold Input Sustain Current	V _{CC} = 3.0V	V _I = 2.0V	-75	—	—	μA
			V _I = 0.8V	75	—	—	
I _{BHH} I _{BHL}	Bus-Hold Input Sustain Current	V _{CC} = 2.3V	V _I = 1.7V	—	—	—	μA
			V _I = 0.7V	—	—	—	
I _{BHHO} I _{BHLO}	Bus-Hold Input Overdrive Current	V _{CC} = 3.6V	V _I = 0 to 3.6V	—	—	±500	μA

LVC Link

NOTES:

1. Pins with Bus-hold are identified in the pin description.
2. Typical values are at V_{CC} = 3.3V, +25°C ambient.

OUTPUT DRIVE CHARACTERISTICS

Symbol	Parameter	Test Conditions ⁽¹⁾		Min.	Max.	Unit
VOH	Output HIGH Voltage	V _{CC} = 2.3V to 3.6V	I _{OH} = -0.1mA	V _{CC} - 0.2	—	V
		V _{CC} = 2.3V	I _{OH} = -4mA	1.9	—	
			I _{OH} = -6mA	1.7	—	
		V _{CC} = 2.7V	I _{OH} = -4mA	2.2	—	
			I _{OH} = -8mA	2	—	
		V _{CC} = 3.0V	I _{OH} = -6mA	2.4	—	
I _{OH} = -12mA	2		—			
VOL	Output LOW Voltage	V _{CC} = 2.3V to 3.6V	I _{OL} = 0.1mA	—	0.2	V
		V _{CC} = 2.3V	I _{OL} = 4mA	—	0.4	
			I _{OL} = 6mA	—	0.55	
		V _{CC} = 2.7V	I _{OL} = 4mA	—	0.4	
			I _{OL} = 8mA	—	0.6	
		V _{CC} = 3.0V	I _{OL} = 6mA	—	0.55	
I _{OL} = 12mA	—		0.8			

LVC Link

NOTE:

1. V_{IH} and V_{IL} must be within the min. or max. range shown in the DC ELECTRICAL CHARACTERISTICS OVER OPERATING RANGE table for the appropriate V_{CC} range. T_A = -40°C to +85°C.

OPERATING CHARACTERISTICS, V_{CC} = 3.3V ± 0.3V, T_A = 25°C

Symbol	Parameter	Test Conditions	Typical	Unit
CPD	Power Dissipation Capacitance per flip-flop Outputs enabled	C _L = 0pF, f = 10MHz		pF
CPD	Power Dissipation Capacitance per flip-flop Outputs disabled			pF

SWITCHING CHARACTERISTICS ⁽¹⁾

Symbol	Parameter	V _{CC} = 2.7V		V _{CC} = 3.3V±0.3V		Unit
		Min.	Max.	Min.	Max.	
t _{PLH}	Propagation Delay xCLK to xQx	2	6.5	2	6.2	ns
t _{PHL}						
t _{PZH}	Output Enable Time xOE to xQx	1.5	6.3	1.5	6.1	ns
t _{PZL}						
t _{PHZ}	Output Disable Time xOE to xQx	1.5	6.2	1.5	6	ns
t _{PLZ}						
t _{SU}	Set-up Time HIGH or LOW, xDx before xCLK	2.5	—	2.5	—	ns
t _H	Hold Time HIGH or LOW, xDx after xCLK	1.5	—	1.5	—	ns
t _w	xCLK Pulse Width HIGH or LOW	3	—	3	—	ns
t _{sk(o)}	Output Skew ⁽²⁾	—	—	—	500	ps

NOTES:

1. See test circuits and waveforms. T_A = -40°C to +85°C.
2. Skew between any two outputs of the same package and switching in the same direction.

TEST CIRCUITS AND WAVEFORMS

TEST CONDITIONS

Symbol	Vcc(1)= 3.3V ±0.3V	Vcc(1)= 2.7V	Vcc(2)= 2.5V ±0.2V	Unit
V _{LOAD}	6	6	2 x V _{cc}	V
V _{IH}	2.7	2.7	V _{cc}	V
V _T	1.5	1.5	V _{cc} / 2	V
V _{LZ}	300	300	150	mV
V _{HZ}	300	300	150	mV
CL	50	50	30	pF

LVC Link

TEST CIRCUITS FOR ALL OUTPUTS

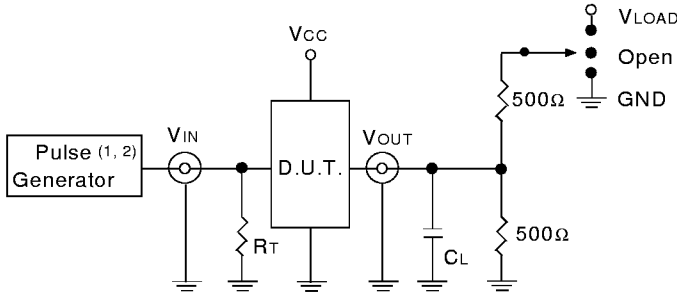

LVC Link

DEFINITIONS:

C_L = Load capacitance: includes jig and probe capacitance.
R_T = Termination resistance: should be equal to Z_{OUT} of the Pulse Generator.

NOTE:

1. Pulse Generator for All Pulses: Rate ≤ 10MHz; t_F ≤ 2.5ns; t_R ≤ 2.5ns.
2. Pulse Generator for All Pulses: Rate ≤ 10MHz; t_F ≤ 2ns; t_R ≤ 2ns.

SWITCH POSITION

Test	Switch
Open Drain Disable Low Enable Low	V _{LOAD}
Disable High Enable High	GND
All Other tests	Open

LVC Link

OUTPUT SKEW - t_{SK}(x)

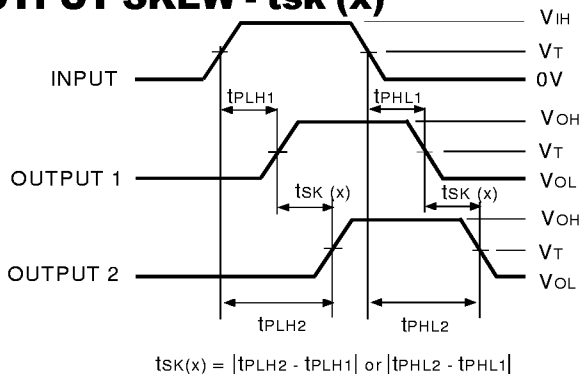

LVC Link

NOTES:

1. For t_{SK}(a) OUTPUT1 and OUTPUT2 are any two outputs.
2. For t_{SK}(b) OUTPUT1 and OUTPUT2 are in the same bank.

PROPAGATION DELAY

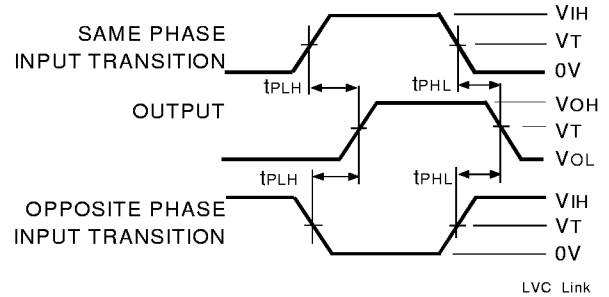

LVC Link

ENABLE AND DISABLE TIMES

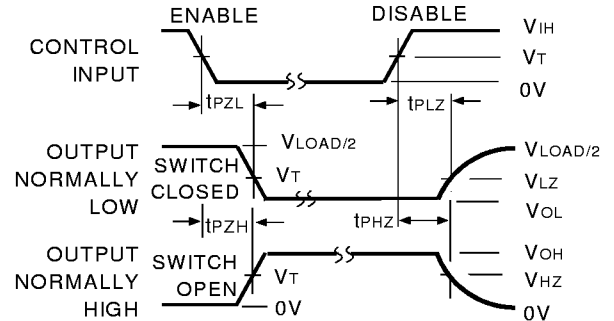

LVC Link

NOTE:

1. Diagram shown for input Control Enable-LOW and input Control Disable-HIGH.

SET-UP, HOLD, AND RELEASE TIMES

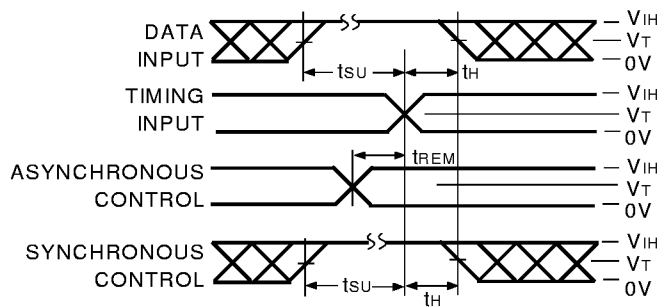

LVC Link

PULSE WIDTH

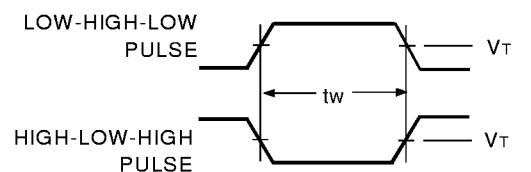

LVC Link

ORDERING INFORMATION

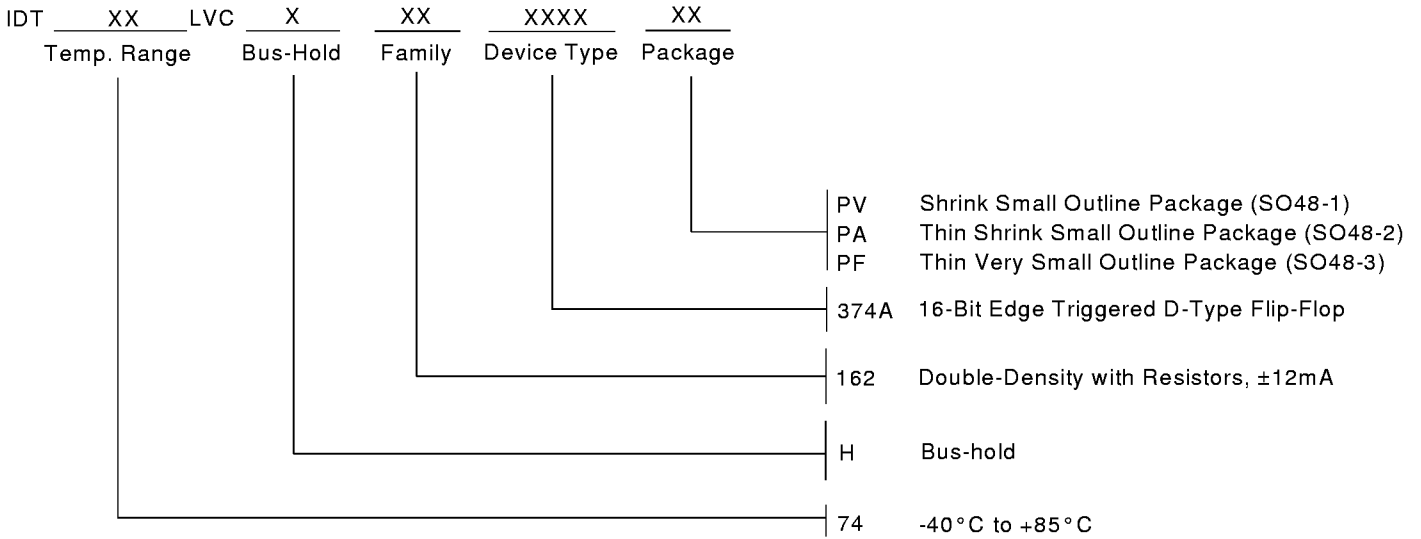

CORPORATE HEADQUARTERS
 2975 Stender Way
 Santa Clara, CA 95054

for SALES:
 800-345-7015 or 408-727-6116
 fax: 408-492-8674
www.idt.com*

*To search for sales office near you, please click the sales button found on our home page or dial the 800# above and press 2.
 The IDT logo is a registered trademark of Integrated Device Technology, Inc.