



3.3V CMOS 16-BIT BUS TRANSCIVER/REGISTER WITH 3-STATE OUTPUTS, 5 VOLT TOLERANT I/O AND BUS-HOLD

IDT74LVCH16646A

FEATURES:

- Typical $t_{sk(o)}$ (Output Skew) < 250ps
- ESD > 2000V per MIL-STD-883, Method 3015; > 200V using machine model (C = 200pF, R = 0)
- $V_{cc} = 3.3V \pm 0.3V$, Normal Range
- $V_{cc} = 2.7V$ to $3.6V$, Extended Range
- CMOS power levels ($0.4\mu W$ typ. static)
- All inputs, outputs, and I/O are 5V tolerant
- Supports hot insertion
- Available in SSOP, TSSOP, and TVSOP packages

DRIVE FEATURES:

- High Output Drivers: $\pm 24mA$
- Reduced system switching noise

APPLICATIONS:

- 5V and 3.3V mixed voltage systems
- Data communication and telecommunication systems

DESCRIPTION:

The LVCH16646A 16-bit bus transceiver and register is built using advanced dual metal CMOS technology. This high-speed, low power device is organized as two independent 8-bit D-type transceivers with 3-state D-type registers. The controls circuitry is organized for multiplexed transmission of data between A bus and B bus either directly or from the internal storage registers. Each 8-bit transceiver/register features direction control (DIR), over-riding Output Enable control (\overline{OE}) and Select lines (SAB and SBA) to select either real-time data or stored data. Separate clock inputs are provided for A and B port registers. Data on the A or B data bus, or both, can be stored in the internal registers by the low-to-high transitions at the appropriate clock pins. Flow-through organization of signal pins simplifies layout. All inputs are designed with hysteresis for improved noise margin.

All pins can be driven from either 3.3V or 5V devices. This feature allows the use of this device as a translator in a mixed 3.3V/5V supply system.

The LVCH16646A has been designed with a $\pm 24mA$ output driver. This driver is capable of driving a moderate to heavy load while maintaining speed performance.

The LVCH16646A has "bus-hold" which retains the inputs' last state whenever the input goes to a high impedance. This prevents floating inputs and eliminates the need for pull-up/down resistors.

FUNCTIONAL BLOCK DIAGRAM

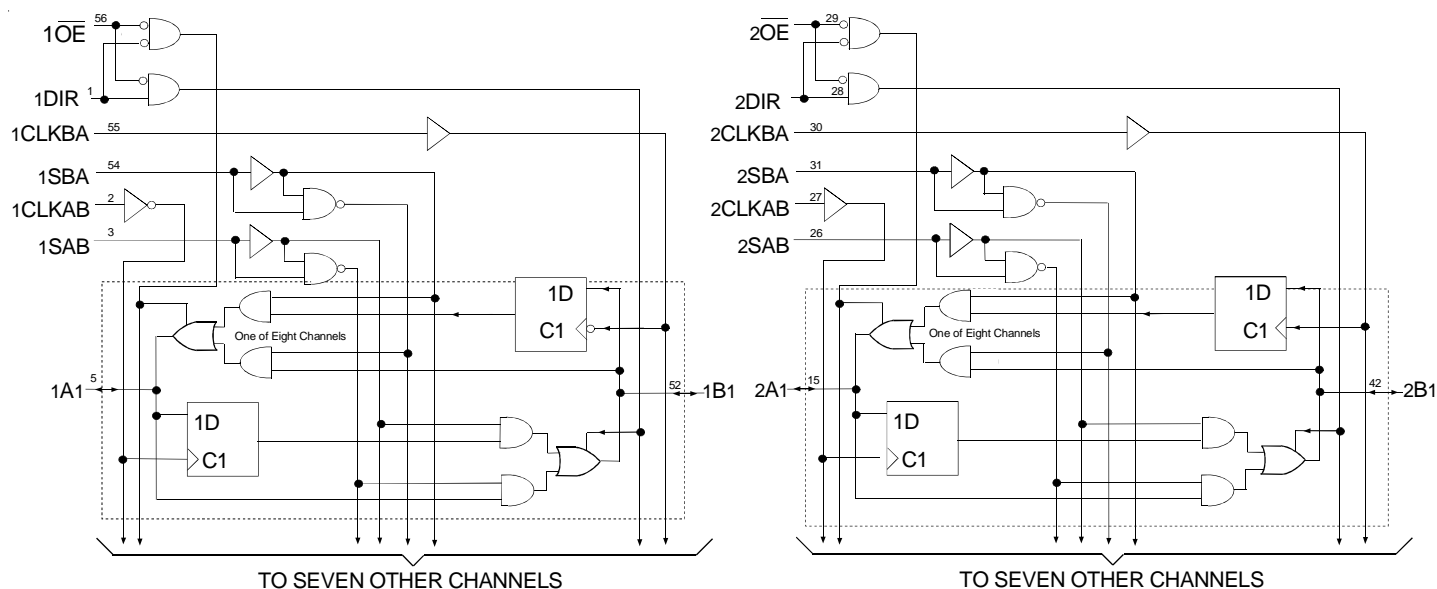

The IDT logo is a registered trademark of Integrated Device Technology, Inc.

INDUSTRIAL TEMPERATURE RANGE

PIN CONFIGURATION

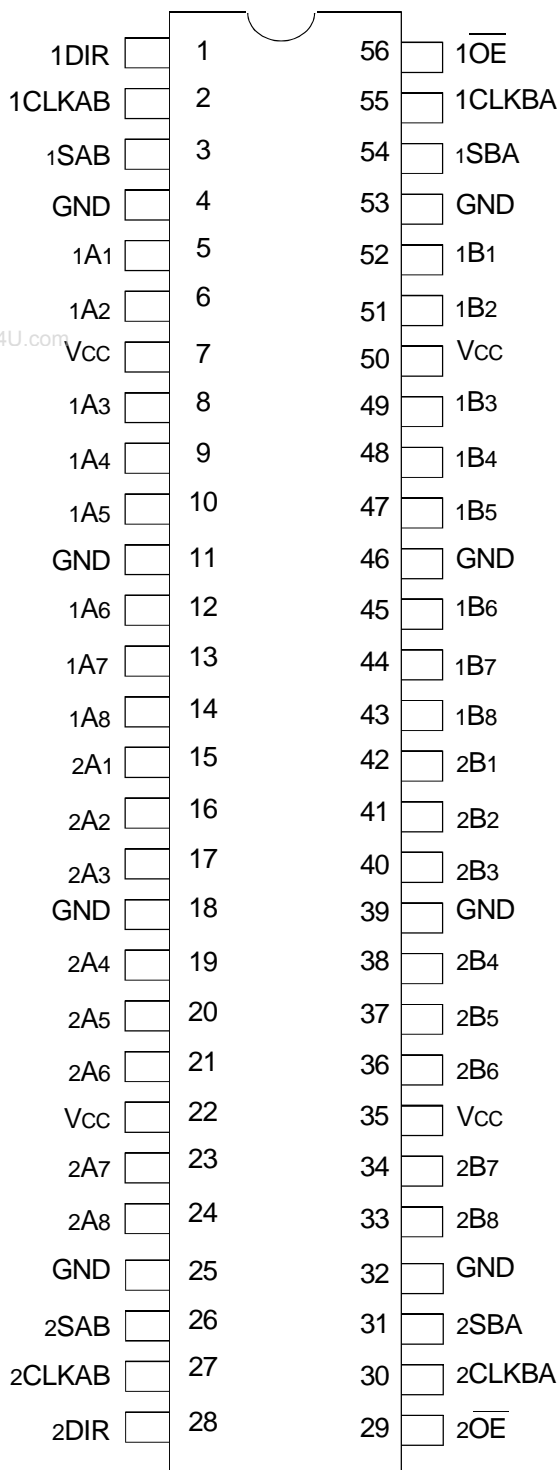

SSOP/ TSSOP/ TVSOP
TOP VIEW

ABSOLUTE MAXIMUM RATINGS⁽¹⁾

Symbol	Description	Max	Unit
VTERM	Terminal Voltage with Respect to GND	-0.5 to +6.5	V
TSTG	Storage Temperature	-65 to +150	°C
I _{OUT}	DC Output Current	-50 to +50	mA
I _{IK} I _{OK}	Continuous Clamp Current, V _I < 0 or V _O < 0	-50	mA
I _{CC} I _{SS}	Continuous Current through each V _{CC} or GND	±100	mA

NOTE:

- Stresses greater than those listed under ABSOLUTE MAXIMUM RATINGS may cause permanent damage to the device. This is a stress rating only and functional operation of the device at these or any other conditions above those indicated in the operational sections of this specification is not implied. Exposure to absolute maximum rating conditions for extended periods may affect reliability.

CAPACITANCE (T_A = +25°C, F = 1.0MHz)

Symbol	Parameter ⁽¹⁾	Conditions	Typ.	Max.	Unit
C _{IN}	Input Capacitance	V _{IN} = 0V	4.5	6	pF
C _{OUT}	Output Capacitance	V _{OUT} = 0V	6.5	8	pF
C _{I/O}	I/O Port Capacitance	V _{IN} = 0V	6.5	8	pF

NOTE:

- As applicable to the device type.

PIN DESCRIPTION

Pin Names	Description
xAx	Data Register A Inputs ⁽¹⁾ Data Register B Outputs
xBx	Data Register B Inputs ⁽¹⁾ Data Register A Outputs
xCLKAB, xCLKBA	Clock Pulse Inputs
xSAB, xSBA	Output Data Source Select Inputs
x \overline{OE}	Output Enable Inputs
xDIR	Direction Control Inputs

NOTE:

- These pins have "Bus-Hold". All other pins are standard inputs, outputs, or I/Os.

FUNCTION TABLE⁽¹⁾

Inputs						Data I/O ⁽²⁾		Operation or Function
x \overline{OE}	xDIR	xCLKAB	xCLKBA	xSAB	xSBA	xAx	xBx	
X	X	↑	X	X	X	Input	Unspecified	Store A, B unspecified ⁽²⁾
X	X	X	↑	X	X	Unspecified	Input	Store B, A unspecified ⁽²⁾
H	X	↑	↑	X	X	Input	Input	Store A and B data
H	X	H or L	H or L	X	X	Input	Input	Isolation, hold storage
L	L	X	X	X	L	Output	Input	Real time B data to A bus
L	L	X	H or L	X	H	Output	Input	Stored B data to A bus
L	H	X	X	L	X	Input	Output	Real time A data to B bus
L	H	H or L	X	H	X	Input	Output	Stored A data to B bus

NOTES:

- H = HIGH Voltage Level
X = Don't Care
L = LOW Voltage Level
↑ = LOW-to-HIGH transition
- The data output functions may be enabled or disabled by various signals at the x \overline{OE} or xDIR inputs. Data input functions are always enabled, i.e. data at the bus pins will be stored on every LOW-to-HIGH transition of the clock inputs.

DC ELECTRICAL CHARACTERISTICS OVER OPERATING RANGE

Following Conditions Apply Unless Otherwise Specified:

Operating Condition: TA = -40°C to +85°C

Symbol	Parameter	Test Conditions		Min.	Typ. ⁽¹⁾	Max.	Unit
VIH	Input HIGH Voltage Level	VCC = 2.3V to 2.7V		1.7	—	—	V
		VCC = 2.7V to 3.6V		2	—	—	
VIL	Input LOW Voltage Level	VCC = 2.3V to 2.7V		—	—	0.7	V
		VCC = 2.7V to 3.6V		—	—	0.8	
IIH IIL	Input Leakage Current	VCC = 3.6V	VI = 0 to 5.5V	—	—	±5	µA
IOZH IOZL	High Impedance Output Current (3-State Output pins)	VCC = 3.6V	VO = 0 to 5.5V	—	—	±10	µA
IOFF	Input/Output Power Off Leakage	VCC = 0V, VIN or VO ≤ 5.5V		—	—	±50	µA
VIK	Clamp Diode Voltage	VCC = 2.3V, IIN = -18mA		—	-0.7	-1.2	V
VH	Input Hysteresis	VCC = 3.3V		—	100	—	mV
ICCL ICCH ICCZ	Quiescent Power Supply Current	VCC = 3.6V	VIN = GND or VCC	—	—	10	µA
			3.6 ≤ VIN ≤ 5.5V ⁽²⁾	—	—	10	
ΔIcc	Quiescent Power Supply Current Variation	One input at VCC - 0.6V, other inputs at VCC or GND		—	—	500	µA

NOTES:

- Typical values are at VCC = 3.3V, +25°C ambient.
- This applies in the disabled state only.

www.DataSheet4U.com

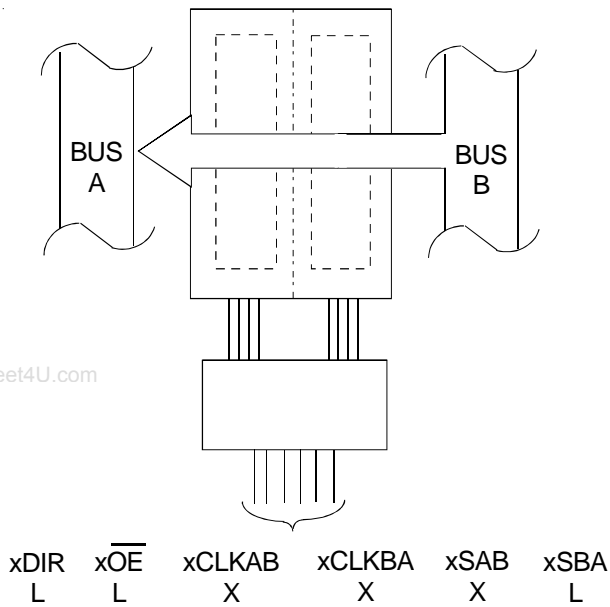

*Real-Time Transfer
Bus B to A*

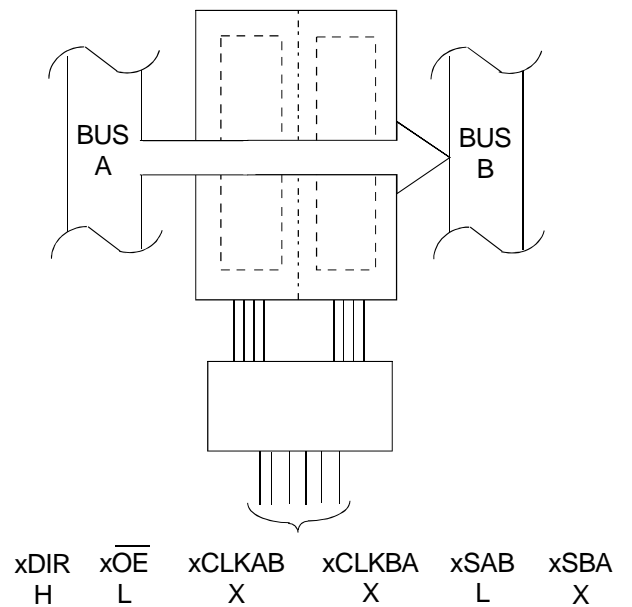

*Real-Time Transfer
Bus A to B*

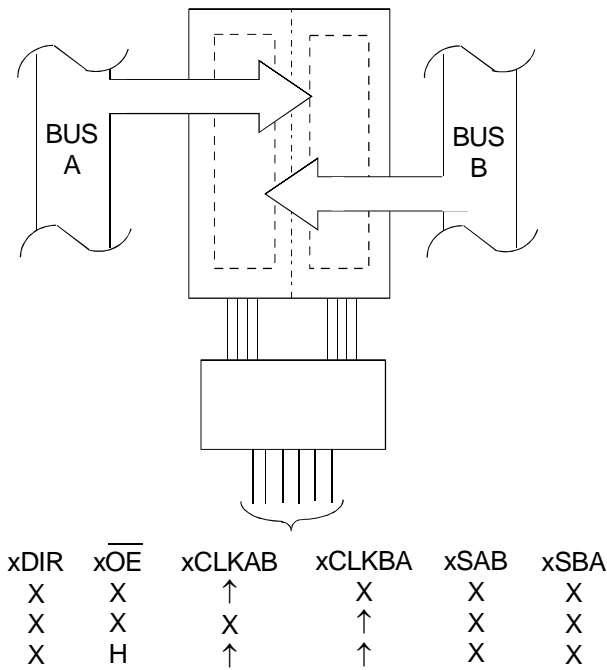

*Storage from
A, B, or A and B*

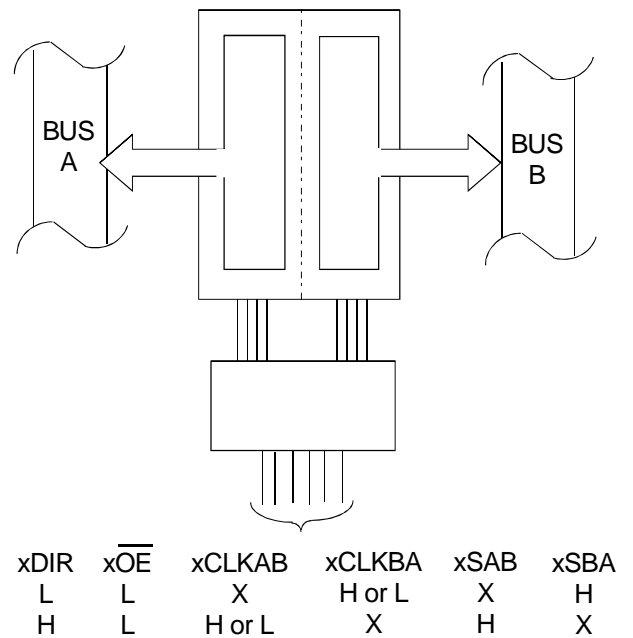

*Transfer Stored
Data to A and/or B*

BUS-HOLD CHARACTERISTICS

Symbol	Parameter ⁽¹⁾	Test Conditions		Min.	Typ. ⁽²⁾	Max.	Unit
IBHH IBHL	Bus-Hold Input Sustain Current	V _{CC} = 3V	V _I = 2V	-75	—	—	μA
			V _I = 0.8V	75	—	—	
IBHH IBHL	Bus-Hold Input Sustain Current	V _{CC} = 2.3V	V _I = 1.7V	—	—	—	μA
			V _I = 0.7V	—	—	—	
IBHHO IBHLO	Bus-Hold Input Overdrive Current	V _{CC} = 3.6V	V _I = 0 to 3.6V	—	—	±500	μA

NOTES:

1. Pins with Bus-Hold are identified in the pin description.
2. Typical values are at V_{CC} = 3.3V, +25°C ambient.

www.DataSheet4U.com

OUTPUT DRIVE CHARACTERISTICS

Symbol	Parameter	Test Conditions ⁽¹⁾		Min.	Max.	Unit
VOH	Output HIGH Voltage	V _{CC} = 2.3V to 3.6V	I _{OH} = -0.1mA	V _{CC} - 0.2	—	V
		V _{CC} = 2.3V	I _{OH} = -6mA	2	—	
		V _{CC} = 2.3V	I _{OH} = -12mA	1.7	—	
		V _{CC} = 2.7V		2.2	—	
		V _{CC} = 3V		2.4	—	
		V _{CC} = 3V	I _{OH} = -24mA	2	—	
VOL	Output LOW Voltage	V _{CC} = 2.3V to 3.6V	I _{OL} = 0.1mA	—	0.2	V
		V _{CC} = 2.3V	I _{OL} = 6mA	—	0.4	
			I _{OL} = 12mA	—	0.7	
		V _{CC} = 2.7V	I _{OL} = 12mA	—	0.4	
		V _{CC} = 3V	I _{OL} = 24mA	—	0.55	

NOTE:

1. V_{IH} and V_{IL} must be within the min. or max. range shown in the DC ELECTRICAL CHARACTERISTICS OVER OPERATING RANGE table for the appropriate V_{CC} range. T_A = -40°C to +85°C.

OPERATING CHARACTERISTICS, V_{CC} = 3.3V ± 0.3V, T_A = 25°C

Symbol	Parameter	Test Conditions	Typical	Unit
CPD	Power Dissipation Capacitance per Transceiver Outputs enabled	C _L = 0pF, f = 10Mhz	60	pF
CPD	Power Dissipation Capacitance per Transceiver Outputs disabled		12	

SWITCHING CHARACTERISTICS(1)

Symbol	Parameter	V _{CC} = 2.7V		V _{CC} = 3.3V ± 0.3V		Unit
		Min.	Max.	Min.	Max.	
f _{MAX}		150	—	150	—	MHz
t _{PLH} t _{PHL}	Propagation Delay xAx to xBx or xBx to xAx	—	6.8	1.3	5.7	ns
t _{PLH} t _{PHL}	Propagation Delay xCLKBA or xCLKAB to xAx or xBx	—	7.9	1.8	6.7	ns
t _{PLH} t _{PHL}	Propagation Delay xSBA or xSAB to xAx or xBx	—	9.2	1.7	7.7	ns
t _{PZH} t _{PZL}	Output Enable Time x \overline{OE} to xAx or Bx	—	8.5	1.3	6.9	ns
t _{PZH} t _{PZL}	Output Enable Time xDIR to xAx or Bx	—	8.5	1.4	7.2	ns
t _{PHZ} t _{PLZ}	Output Disable Time x \overline{OE} to xAx or Bx	—	7.7	2.1	6.9	ns
t _{PHZ} t _{PLZ}	Output Disable Time xDIR to xAx or Bx	—	7.8	2	7	ns
t _{SU}	Set-up Time xAx or xBx before CLKAB \uparrow or CLKBA \uparrow	3.2	—	2.9	—	ns
t _H	Hold Time xAx or xBx after CLKAB \uparrow or CLKBA \uparrow	0	—	0.3	—	ns
t _w	Pulse Duration, CLK HIGH or LOW	3.3	—	3.3	—	ns
t _{SK(O)}	Output Skew ⁽²⁾	—	—	—	500	ps

NOTES:

1. See TEST CIRCUITS AND WAVEFORMS. T_A = - 40°C to + 85°C.
2. Skew between any two outputs of the same package and switching in the same direction.

TEST CIRCUITS AND WAVEFORMS

TEST CONDITIONS

Symbol	V _{CC} ⁽¹⁾ =3.3V±0.3V	V _{CC} ⁽¹⁾ =2.7V	V _{CC} ⁽²⁾ =2.5V±0.2V	Unit
V _{LOAD}	6	6	2 x V _{CC}	V
V _{IH}	2.7	2.7	V _{CC}	V
V _T	1.5	1.5	V _{CC} / 2	V
V _{LZ}	300	300	150	mV
V _{HZ}	300	300	150	mV
C _L	50	50	30	pF

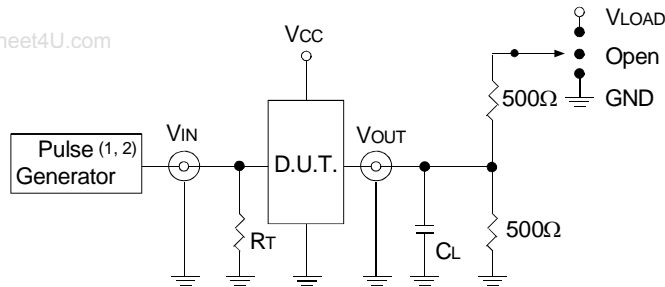

Test Circuit for All Outputs

DEFINITIONS:

C_L = Load capacitance: includes jig and probe capacitance.
R_T = Termination resistance: should be equal to Z_{OUT} of the Pulse Generator.

NOTES:

1. Pulse Generator for All Pulses: Rate ≤ 10MHz; t_r ≤ 2.5ns; t_r ≤ 2.5ns.
2. Pulse Generator for All Pulses: Rate ≤ 10MHz; t_r ≤ 2ns; t_r ≤ 2ns.

SWITCH POSITION

Test	Switch
Open Drain Disable Low Enable Low	V _{LOAD}
Disable High Enable High	GND
All Other Tests	Open

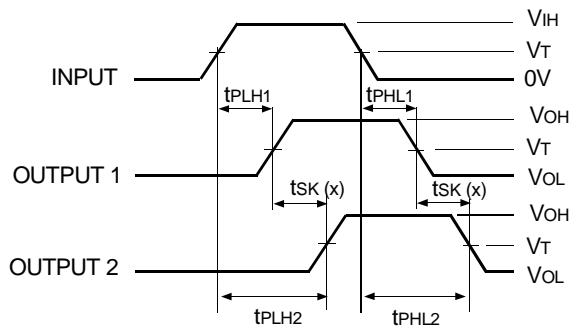

$$tsk(x) = |t_{PLH2} - t_{PLH1}| \text{ or } |t_{PHL2} - t_{PHL1}|$$

Output Skew - tsk(x)

NOTES:

1. For tsk(o) OUTPUT1 and OUTPUT2 are any two outputs.
2. For tsk(b) OUTPUT1 and OUTPUT2 are in the same bank.

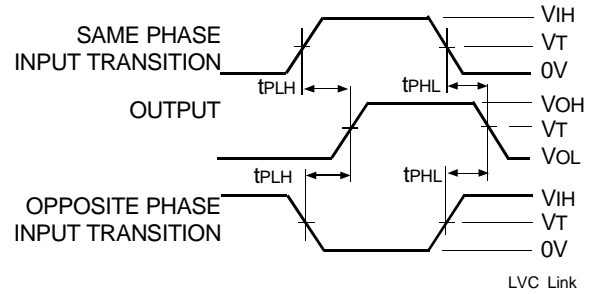

Propagation Delay

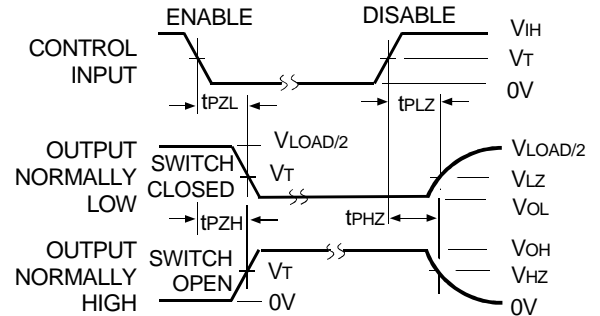

Enable and Disable Times

NOTE:

1. Diagram shown for input Control Enable-LOW and input Control Disable-HIGH.

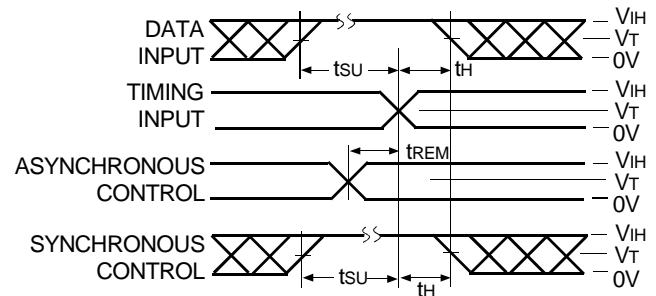

Set-up, Hold, and Release Times

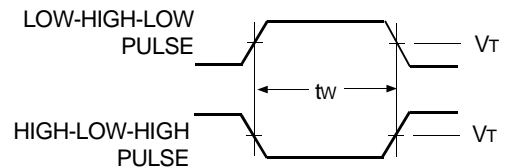

Pulse Width

ORDERING INFORMATION

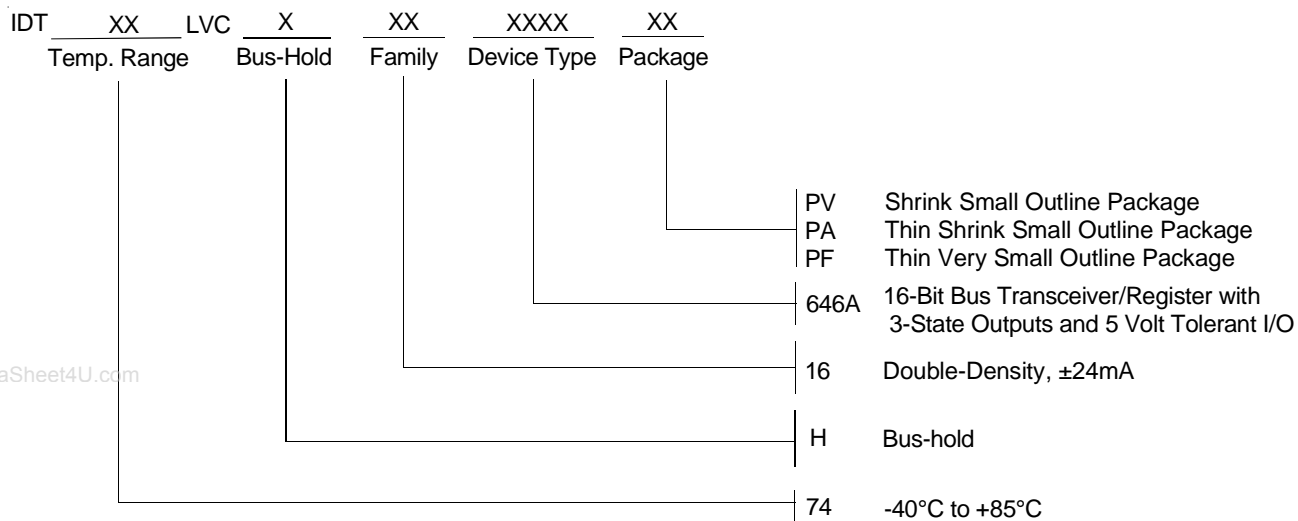

CORPORATE HEADQUARTERS
 2975 Stender Way
 Santa Clara, CA 95054

for SALES:
 800-345-7015 or 408-727-6116
 fax: 408-492-8674
 www.idt.com

for Tech Support:
 logichelp@idt.com
 (408) 654-6459