

1.SCOPE

SHOULDER's SAW filter series have broad line up products meeting all broadcast standard including NTSC,PAL and SECAM systems. These filters are composed of two interdigital transducers on a single-crystal, piezoelectrical chip. they are used in electronic equipments such as TV and so on.

2.Construction

2.1 Dimension and materials

Manufacturer's name : HAODA ELECTRONICS Co. LTD(CHINA)

Type : IF389B1M

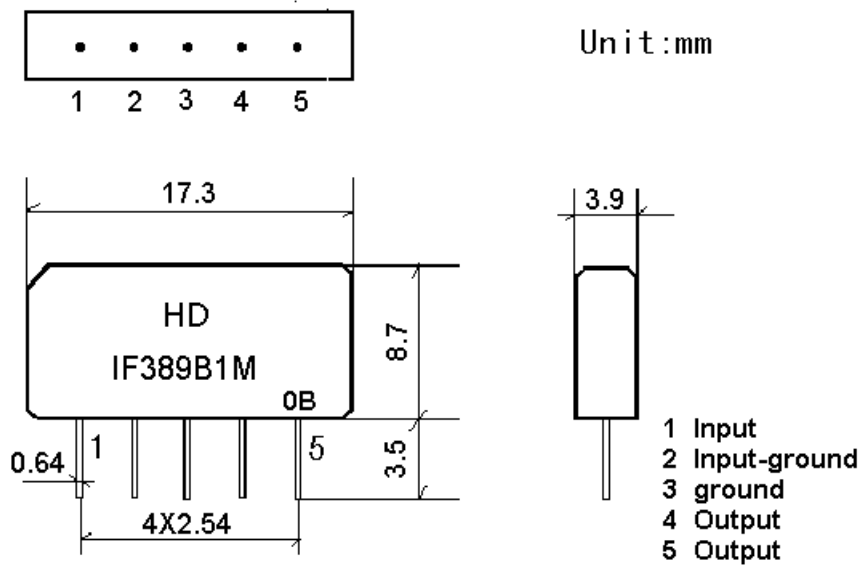

0: year(0,1,2,3,4,5,6,7,8,9)

B:product in this quarter(A:1~3,B:4~6,C:7~9,D:10~12)

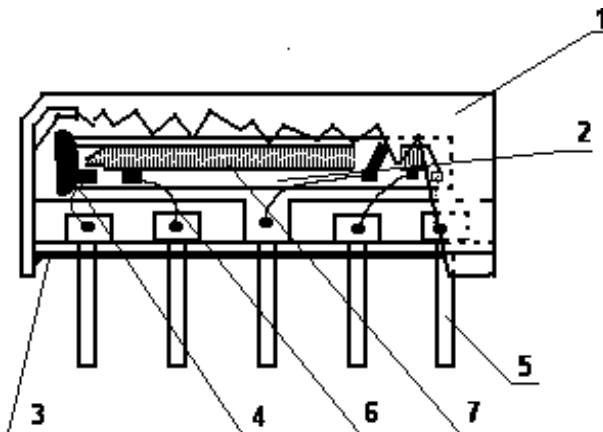

Components	Materials
1.Outer casing	PPS
2.Substrate	Lithium niobate
3.Base	Epoxy resin
4.Absorber	Epoxy resin
5.Lead	Cu alloy+Au plate
6.Bonding wire	AlSi alloy
7.Electrode	Al

2.2. Circuit construction, measurement circuit

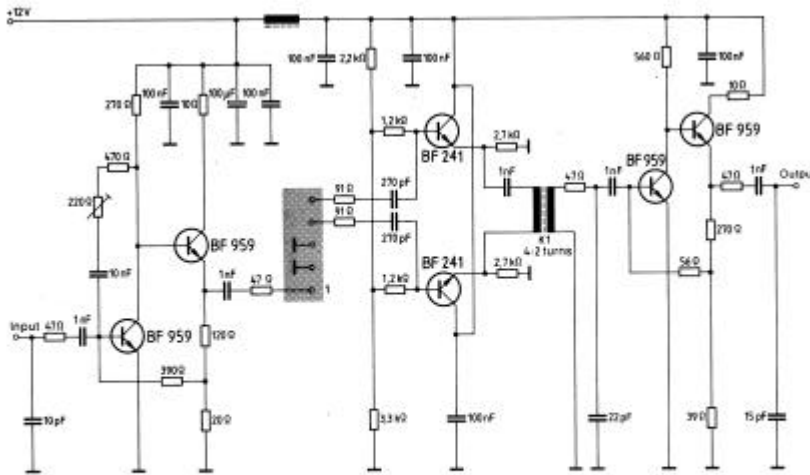

Test circuit for SIP-5 filter
Input impedance of the symmetrical post-amplifier: 2 kΩ in parallel with 3 pF

3.Characteristics

Standard atmospheric conditions

Unless otherwise specified , the standard rang of atmospheric conditions for making measurements and tests is as follows;

- Ambient temperature : 15 to 35
- Relative humidity : 25% to 85%
- Air pressure : 86kPa to 106kPa

Operating temperature rang

Operating temperature rang is the rang of ambient temperatures in which the filter can be

operated continuously. -10 ~ +60

Storage temperature rang

Storage temperature rang is the rang of ambient temperatures at which the filter can be stored

without damage.

Conditions are as specified elsewhere in these specifications. -40 ~ +70

Reference temperature +25

3.1 Maximum Rating

DC voltage	VDC	12	V	Between any terminals
AC voltage	Vpp	10	V	Between any terminals

3.2 Electrical Characteristics

Source impedance $Z_s=50$

Load impedance $Z_L=2k //3pF$ $T_A=25$

Items	Freq	Min	typ	max	
Insertion attenuation Reference level	37.4MHz	16.1	17.6	19.1	dB
Relative attenuation	38.9MHz	4.2	5.7	7.2	dB
	34.47MHz	2.3	3.8	5.3	dB
	32.4MHz	18.8	20.3	-	dB
	33.4MHz	19.4	20.9	-	dB
	30.9MHz	44.0	58		dB
	40.4MHz	42.0	52		dB
	41.4MHz	42.0	50		dB
Sidelobe	25.00~30.90MHz	35.0	45		dB
	40.40~45.00MHz	35.0	42		dB
Temperature coefficient		-72			Ppm/k

3.3 Environmental Performance Characteristics

Item Test condition	Allowable change of absolute Level at center frequency(dB)
High temperature test 70 1000H	< 1.0
Low temperature test -40 1000H	< 1.0
Humidity test 40 90-95% 1000H	< 1.0
Thermal shock -20 ==25 ==80 20 cycle 30M 10M 30M	< 1.0
Solder temperature test Sold temp.260 for 10 sec.	< 1.0
Soldering Immerse the pins melt solder at 260 +5/-0 for 5 sec.	More then 95% of total area of the pins should be covered with solder

3.4 Mechanical Test

Item Test condition	Allowable change of absolute Level at center frequency(dB)
Vibration test 600-3300rpm amplitude 1.5mm 3 directions 2 H each	<1.0
Drop test On maple plate from 1 m high 3 times	<1.0
Lead pull test Pull with 1 kg force for 30 seconds	<1.0

Lead bend test 90° bending with 500g weigh 2 times	<1.0
---	------

3.5 Voltage Discharge Test

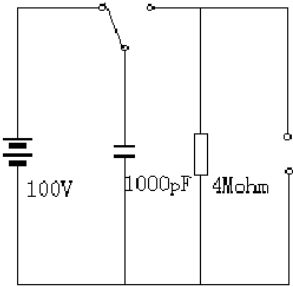
Item Test condition	Allowable change of absolute Level at center frequency(dB)
Surge test Between any two electrode 	<1.0

3.6 Frequency response

CH1 S21 log MAG 10 dB/ REF -17.6 dB 3: -20.536 dB

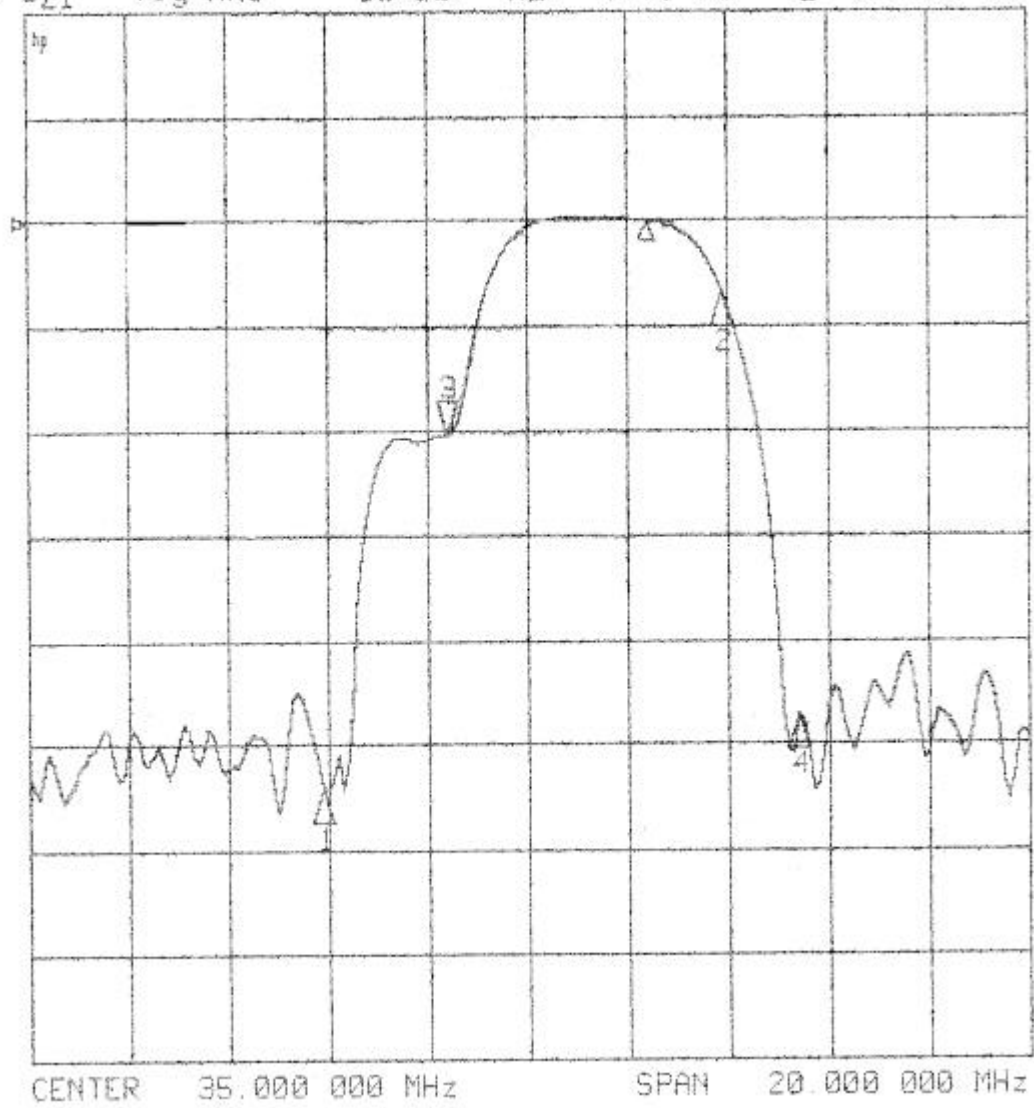

CH1 S21 delay 30 ns/ REF 1.17 μ s 2: 17.228 ns
CH2 S21 log MAG 1 dB/ REF -17.6 dB 2 -5.6048 dB

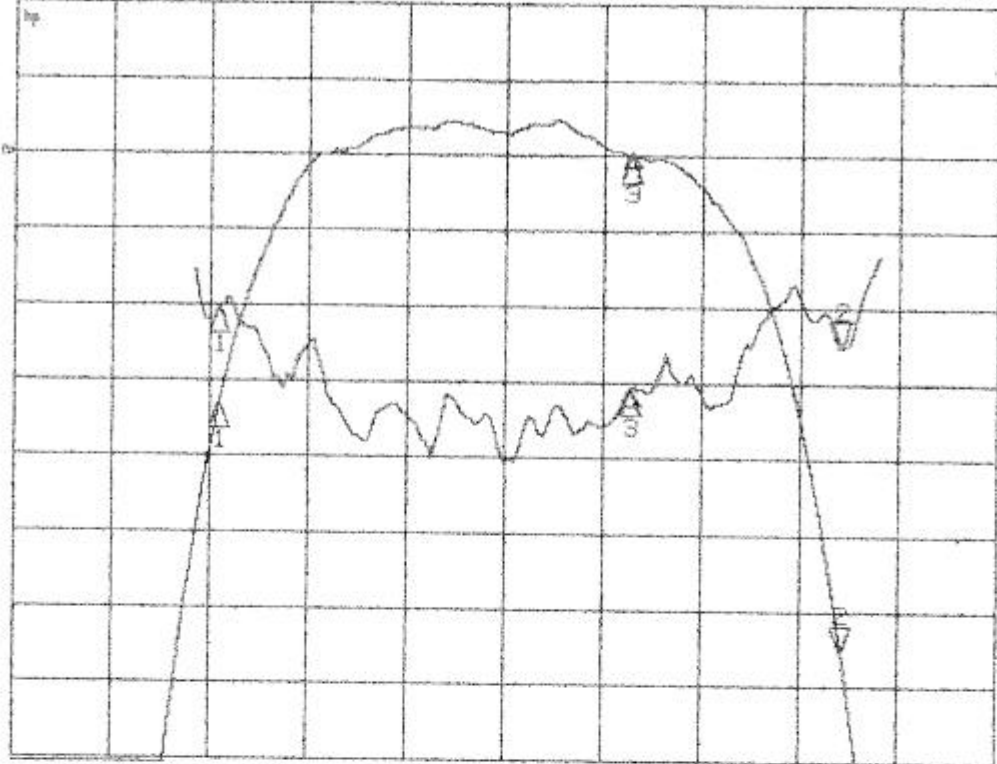

CENTER 36.500 000 MHz SPAN 7.000 000 MHz

CH1 S21 log MAG 10 dB/ REF -17.6 dB

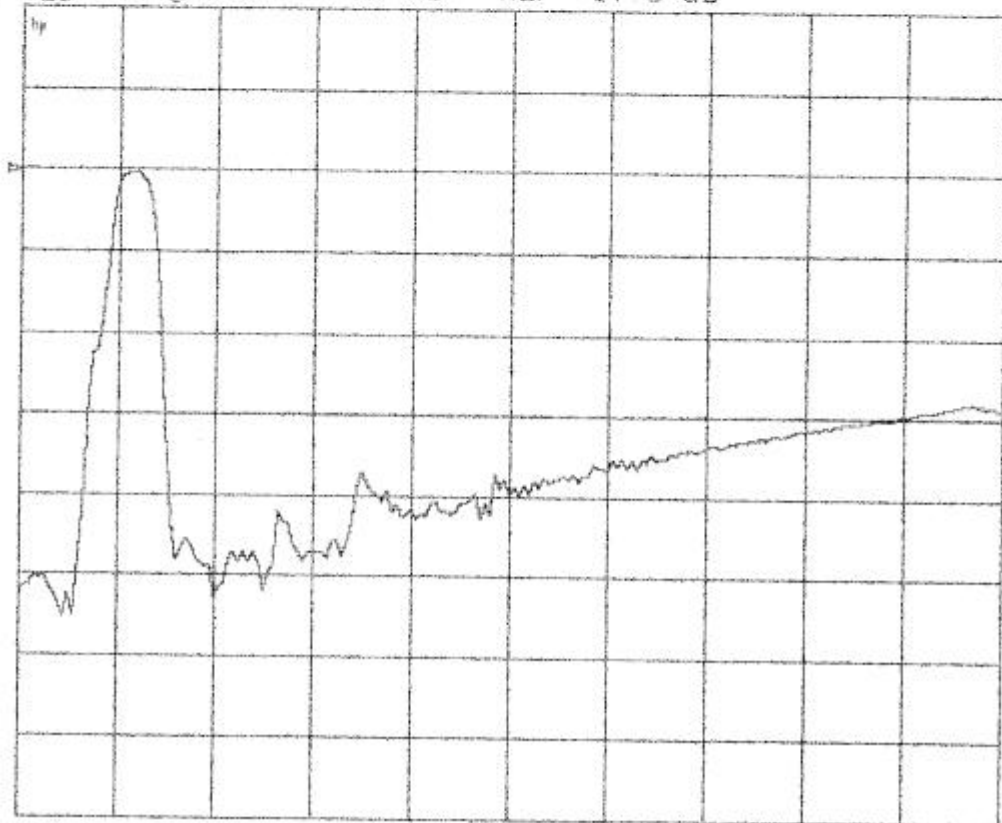

START 25.000 000 MHz STOP 125.000 000 MHz