

# IFX1050G

High Speed CAN-Transceiver

## Data Sheet

Rev. 1.0, 2009-05-14

Standard Products

## Table of Contents

<b>1</b>	<b>Overview</b> .....	<b>3</b>
<b>2</b>	<b>Block Diagram</b> .....	<b>4</b>
<b>3</b>	<b>Pin Configuration</b> .....	<b>5</b>
3.1	Pin Assignment .....	5
3.2	Pin Definitions and Functions .....	5
<b>4</b>	<b>Operation Modes</b> .....	<b>6</b>
4.1	Normal Mode .....	6
4.2	Stand - By Mode .....	6
4.3	Receive - Only Mode .....	6
<b>5</b>	<b>Electrical Characteristics</b> .....	<b>7</b>
5.1	Absolute Maximum Ratings .....	7
5.2	Functional Range .....	7
5.3	Thermal Resistance .....	7
<b>6</b>	<b>Electrical Characteristics</b> .....	<b>8</b>
<b>7</b>	<b>Application Information</b> .....	<b>12</b>
7.1	Further Application Information .....	12
<b>8</b>	<b>Package Outlines</b> .....	<b>13</b>
<b>9</b>	<b>Revision History</b> .....	<b>14</b>



## 1 Overview

### Features

- CAN data transmission rates from 1 kBaud up to 1 MBaud
- Receive - Only Mode and Stand - By Mode
- Optimized Electromagnetic Compatibility (EMC)
- Optimized for a high immunity against Electromagnetic Interference (EMI)
- Bus pins are short circuit proof
- Over - temperature protection
- Very wide temperature range (-40 °C up to 125 °C)
- Green Product (RoHS compliant)

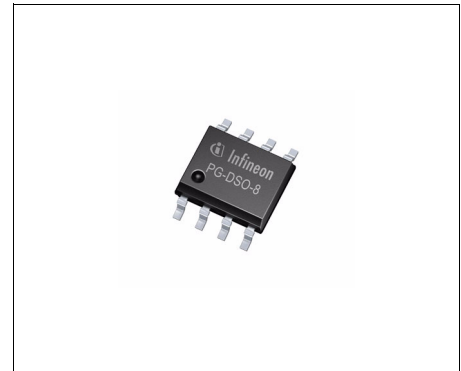

PG-DSO-8

### Description

The IFX1050G is optimized for high speed differential mode data transmission in industrial applications and it is compliant to ISO11898-2. The transceiver IFX1050G works as an interface between the CAN protocol controller and the physical differential bus in High Speed CAN applications. It supports data transmission rates from 1 kBaud up to 1 MBaud.

The IFX1050G has three different operation modes:

The Normal Mode, the Receive - Only Mode and the Stand - By Mode. The mode selection is controlled by the logical input pins RM and INH.

The IC is based on the **Smart Power Technology SPT®** which allows bipolar and CMOS control circuitry in accordance with DMOS power devices existing on the same monolithic circuit. The IFX1050G is designed to withstand the severe conditions in industrial applications and provides excellent EMC performance within a broad frequency range.

Type	Package	Marking
IFX1050G	PG-DSO-8	IFX1050G

## 2 Block Diagram

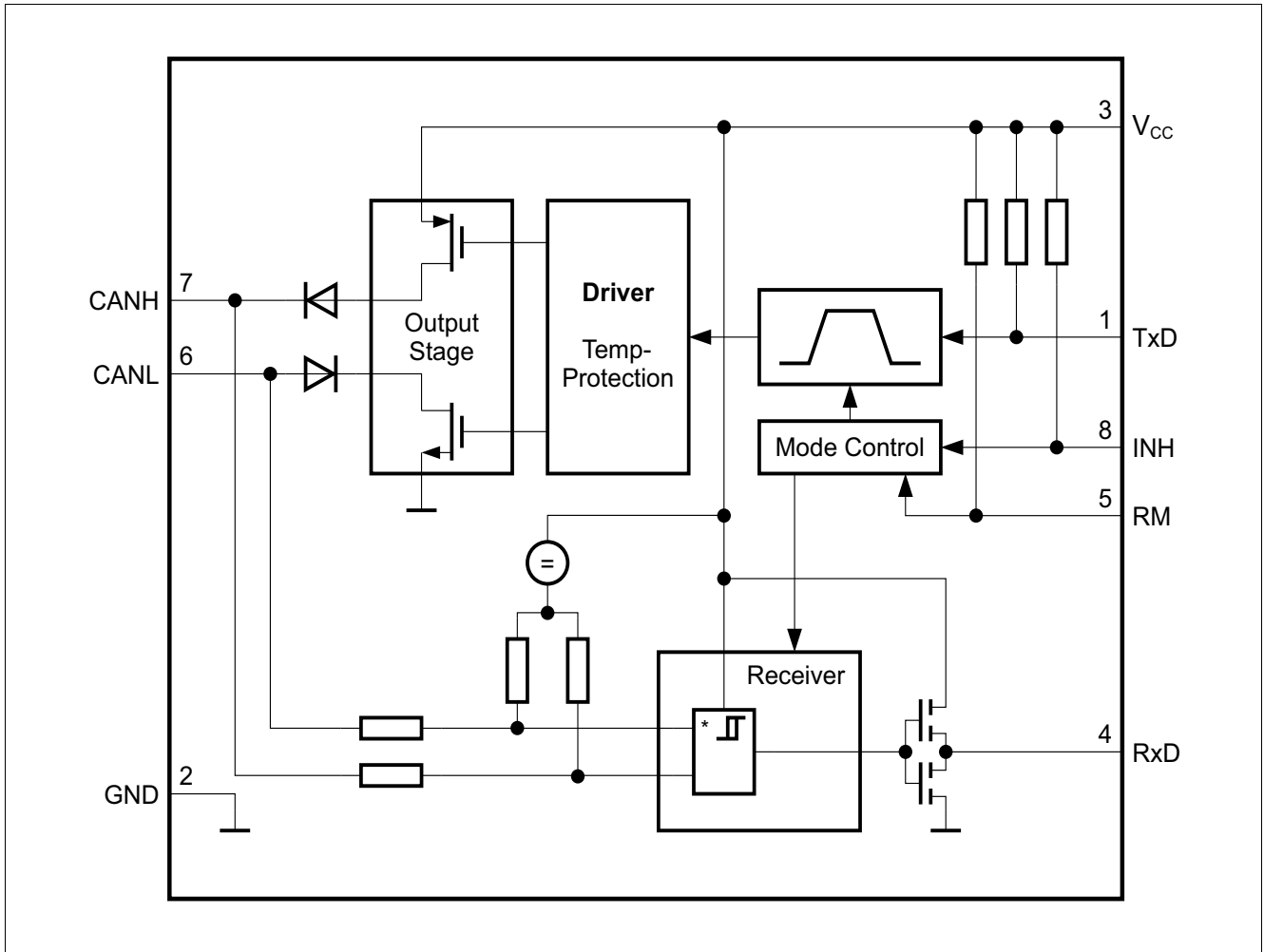

Figure 1 Block Diagram

### 3 Pin Configuration

#### 3.1 Pin Assignment

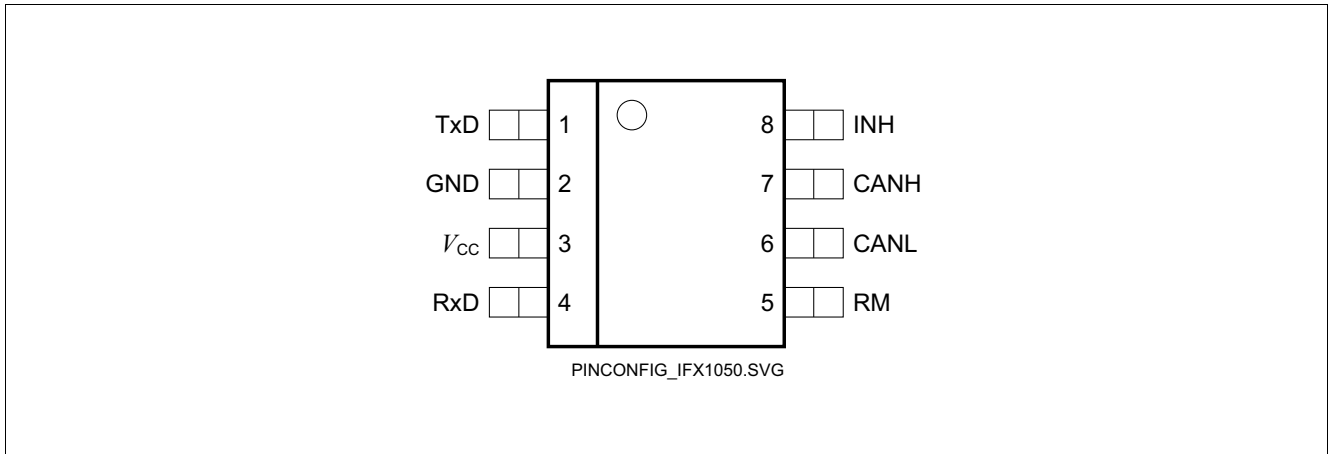
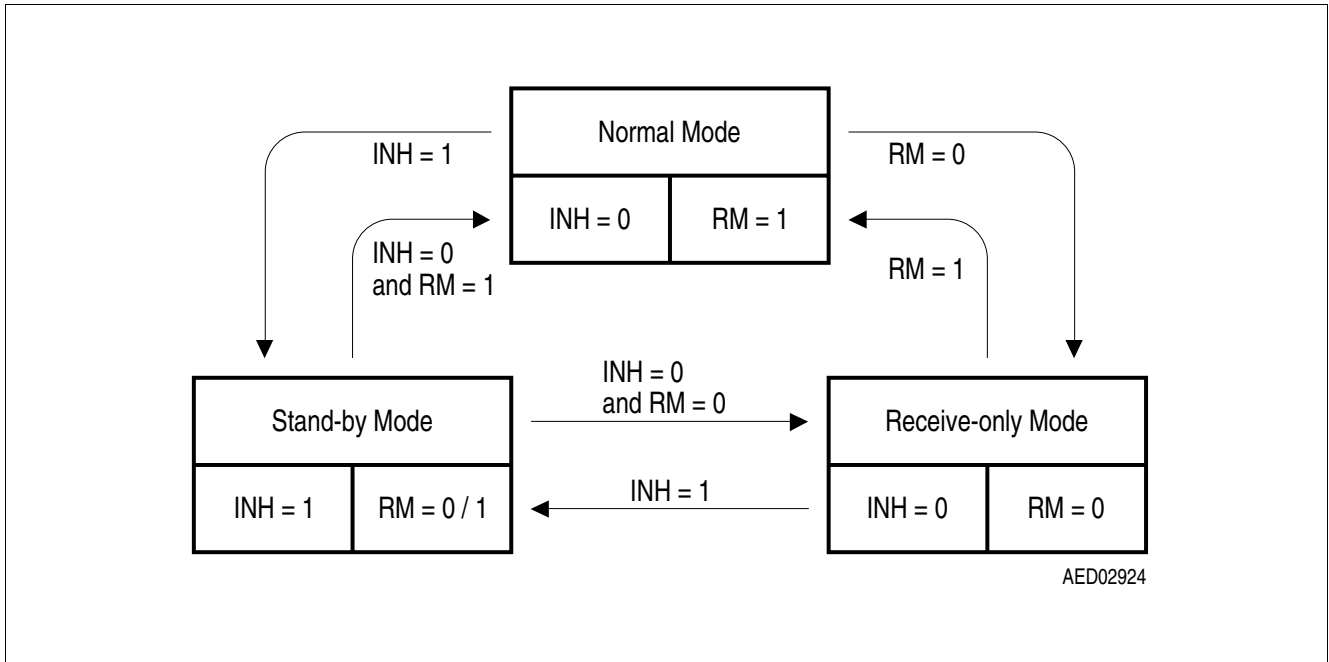

Figure 2 Pin Configuration

#### 3.2 Pin Definitions and Functions

Pin	Symbol	Function
1	TxD	<b>CAN transmit data input;</b> 20 kΩ pull - up, "LOW" in dominant state
2	GND	<b>Ground</b>
3	V <sub>CC</sub>	<b>5 V Supply input</b>
4	RxD	<b>CAN receive data output;</b> "LOW" in dominant state, integrated pull - up
5	RM	<b>Receive - Only input;</b> control input, integrated 20 kΩ pull - up, "LOW" to activate Receive - Only Mode
6	CANL	<b>Low line I/O;</b> "LOW" in dominant state
7	CANH	<b>High line I/O;</b> "HIGH" in dominant state
8	INH	<b>Inhibit Input;</b> control input, 20 kΩ pull - up, "LOW" to activate Normal Mode

## 4 Operation Modes



**Figure 3 Mode State Diagram**

The IFX1050G is equipped with three different operation modes.

### 4.1 Normal Mode

In the Normal Mode the device is able to receive data from the CAN bus and to transmit messages to the CAN bus. The IFX1050G enters Normal Mode by setting the INH input to logical “LOW” and the RM input to logical “HIGH” (see [Figure 3](#)).

### 4.2 Stand - By Mode

Stand - By Mode is a Low - Power mode with reduced current consumption on the power supply  $V_{CC}$ .

In Stand - By Mode the receiver and the transceiver of the IFX1050G are disabled and the device can not receive any data from the CAN bus, nor transmit any data to the CAN bus. The IFX1050G enters Stand - By Mode by setting the INH input to logical “HIGH” (see [Figure 3](#)).

When the Stand - By mode is not used the INH pin has to be connected to GND in order to switch the IFX1050G permanently into Normal Mode.

### 4.3 Receive - Only Mode

The Receive - Only Mode can be used for diagnostic purposes (to check the bus connections between the nodes) as well as to prevent the bus being blocked by a faulty permanent dominant TxD input signal. In Receive - Only Mode the output stage of the transceiver IFX1050G is disabled. The IFX1050G can not send any data to the CAN bus, but is still able to receive data from the CAN bus. The IFX1050G enters Receive - Only Mode by setting the RM input and the INH input to logical “LOW” (see [Figure 3](#)).

In case the Receive - Only Mode is not used, the RM pin can be left open or it can be also connected to the power supply  $V_{CC}$ .

## 5 Electrical Characteristics

### 5.1 Absolute Maximum Ratings

Table 1 Absolute Maximum Ratings

Parameter	Symbol	Limit Values		Unit	Remarks
		Min.	Max.		
<b>Voltages</b>					
Supply voltage	$V_{CC}$	-0.3	6.5	V	–
CAN input voltage (CANH, CANL)	$V_{CANH/L}$	-40	40	V	–
Logic voltages at INH, RM, TxD, RxD	$V_I$	-0.3	$V_{CC}$	V	$0\text{ V} < V_{CC} < 5.5\text{ V}$
Electrostatic discharge voltage at CANH, CANL	$V_{ESD}$	-6	6	kV	human body model (100 pF via 1.5 k $\Omega$ )
Electrostatic discharge voltage	$V_{ESD}$	-2	2	kV	human body model (100 pF via 1.5 k $\Omega$ )
<b>Temperatures</b>					
Junction temperature	$T_j$	-40	160	$^{\circ}\text{C}$	–

Note: Stresses above the ones listed here may cause permanent damage to the device. Exposure to absolute maximum rating conditions for extended periods may affect device reliability.

Note: Integrated protection functions are designed to prevent IC destruction under fault conditions described in the data sheet. Fault conditions are considered as “outside” normal operating range. Protection functions are not designed for continuous repetitive operation.

### 5.2 Functional Range

Table 2 Functional Range

Parameter	Symbol	Limit Values		Unit	Remarks
		Min.	Max.		
Supply voltage	$V_{CC}$	4.5	5.5	V	–
Junction temperature	$T_j$	-40	125	$^{\circ}\text{C}$	–
<b>Thermal Shutdown (junction temperature)</b>					
Thermal shutdown temperature	$T_{jSD}$	160	200	$^{\circ}\text{C}$	10 $^{\circ}\text{C}$ hysteresis

Note: Within the functional or operating range, the IC operates as described in the circuit description. The electrical characteristics are specified within the conditions given in the Electrical Characteristics table.

### 5.3 Thermal Resistance

Pos.	Parameter	Symbol	Limit Values			Unit	Conditions
			Min.	Typ.	Max.		
5.3.1	Junction to Ambient <sup>1)</sup>	$R_{thJA}$	–	–	185	K/W	

1) Not subject to production test, specified by design.

## 6 Electrical Characteristics

**Table 3 Electrical Characteristics**

4.5 V <  $V_{CC}$  < 5.5 V;  $R_L = 60 \Omega$ ;  $V_{INH} < V_{INH,ON}$ ;  $-40 \text{ }^\circ\text{C} < T_j < 125 \text{ }^\circ\text{C}$ ; all voltages with respect to ground; positive current flowing into pin; unless otherwise specified.

Parameter	Symbol	Limit Values			Unit	Remarks
		Min.	Typ.	Max.		
<b>Current Consumption</b>						
Current consumption	$I_{CC}$	–	6	10	mA	Recessive state; $V_{TxD} = V_{CC}$
Current consumption	$I_{CC}$	–	45	70	mA	Dominant state; $V_{TxD} = 0 \text{ V}$
Current consumption	$I_{CC}$	–	6	10	mA	Receive - Only Mode; RM = "LOW"
Current consumption	$I_{CC,STB}$	–	1	10	$\mu\text{A}$	Stand - By Mode; TxD = RM = "High"
<b>Receiver Output RxD</b>						
HIGH level output current	$I_{RD,H}$	–	-4	-2	mA	$V_{RD} = 0.8 \times V_{CC}$ , $V_{diff} < 0.4 \text{ V}^{(1)}$
LOW level output current	$I_{RD,L}$	2	4	–	mA	$V_{RD} = 0.2 \times V_{CC}$ , $V_{diff} > 1 \text{ V}^{(1)}$
<b>Transmission Input TxD</b>						
HIGH level input voltage threshold	$V_{TD,H}$	–	$0.5 \times V_{CC}$	$0.7 \times V_{CC}$	V	Recessive state
LOW level input voltage threshold	$V_{TD,L}$	$0.3 \times V_{CC}$	$0.4 \times V_{CC}$	–	V	Dominant state
TxD pull-up resistance	$R_{TD}$	10	25	50	k $\Omega$	–
<b>Inhibit Input (pin INH)</b>						
HIGH level input voltage threshold	$V_{INH,H}$	–	$0.5 \times V_{CC}$	$0.7 \times V_{CC}$	V	Stand - By Mode;
LOW level input voltage threshold	$V_{INH,L}$	$0.3 \times V_{CC}$	$0.4 \times V_{CC}$	–	V	Normal Mode
INH pull-up resistance	$R_{INH}$	10	25	50	k $\Omega$	–
<b>Receive only Input (pin RM)</b>						
HIGH level input voltage threshold	$V_{RM,H}$	–	$0.5 \times V_{CC}$	$0.7 \times V_{CC}$	V	Normal Mode
LOW level input voltage threshold	$V_{RM,L}$	$0.3 \times V_{CC}$	$0.4 \times V_{CC}$	–	V	Receive - Only Mode
RM pull-up resistance	$R_{RM}$	10	25	50	k $\Omega$	–



**Electrical Characteristics**
**Table 3 Electrical Characteristics (cont'd)**

4.5 V <  $V_{CC}$  < 5.5 V;  $R_L = 60 \Omega$ ;  $V_{INH} < V_{INH,ON}$ ;  $-40 \text{ }^\circ\text{C} < T_j < 125 \text{ }^\circ\text{C}$ ; all voltages with respect to ground; positive current flowing into pin; unless otherwise specified.

Parameter	Symbol	Limit Values			Unit	Remarks
		Min.	Typ.	Max.		
<b>Bus Receiver</b>						
Differential receiver threshold voltage, recessive to dominant edge	$V_{diff,d}$	–	0.75	0.90	V	$-7 \text{ V} < (V_{CANH}, V_{CANL}) < 12 \text{ V}$ $V_{diff} = V_{CANH} - V_{CANL}$
Differential receiver threshold voltage dominant to recessive edge	$V_{diff,r}$	0.50	0.60	–	V	$-7 \text{ V} < (V_{CANH}, V_{CANL}) < 12 \text{ V}$ $V_{diff} = V_{CANH} - V_{CANL}$
Common Mode Range	CMR	-7	–	12	V	$V_{CC} = 5 \text{ V}$
Differential receiver hysteresis	$V_{diff,hys}$	–	150	–	mV	–
CANH, CANL input resistance	$R_i$	10	20	30	k $\Omega$	Recessive state
Differential input resistance	$R_{diff}$	20	40	60	k $\Omega$	Recessive state
<b>Bus Transmitter</b>						
CANL/CANH recessive output voltage	$V_{CANL/H}$	$0.4 \times V_{CC}$	–	$0.6 \times V_{CC}$	V	$V_{TxD} = V_{CC}$
CANH, CANL recessive output voltage difference $V_{diff} = V_{CANH} - V_{CANL}$ , no load	$V_{diff}$	-1	–	0.05	V	$V_{TxD} = V_{CC}$
CANL dominant output voltage	$V_{CANL}$	–	–	2.0	V	$V_{TxD} = 0 \text{ V};$ $V_{CC} = 5 \text{ V}$
CANH dominant output voltage	$V_{CANH}$	2.8	–	–	V	$V_{TxD} = 0 \text{ V};$ $V_{CC} = 5 \text{ V}$
CANH, CANL dominant output voltage difference $V_{diff} = V_{CANH} - V_{CANL}$	$V_{diff}$	1.5	–	3.0	V	$V_{TxD} = 0 \text{ V};$ $V_{CC} = 5 \text{ V}$
CANL short circuit current	$I_{CANLsc}$	50	120	200	mA	$V_{CANLshort} = 18 \text{ V}$
CANH short circuit current	$I_{CANHsc}$	-200	-120	-50	mA	$V_{CANHshort} = 0 \text{ V}$
Output current CANH / CANL	$I_{CANH/L,ik}$	-50	-300	-400	$\mu\text{A}$	$V_{CC} = 0 \text{ V},$ $V_{CANH} = V_{CANL} = -7 \text{ V}$
		-50	-100	-150	$\mu\text{A}$	$V_{CC} = 0 \text{ V},$ $V_{CANH} = V_{CANL} = -2 \text{ V}$
Output current CANH / CANL	$I_{CANH/L,ik}$	50	280	400	$\mu\text{A}$	$V_{CC} = 0 \text{ V},$ $V_{CANH} = V_{CANL} = 7 \text{ V}$
		50	100	150	$\mu\text{A}$	$V_{CC} = 0 \text{ V},$ $V_{CANH} = V_{CANL} = 2 \text{ V}$

**Electrical Characteristics**
**Table 3 Electrical Characteristics (cont'd)**

4.5 V <  $V_{CC}$  < 5.5 V;  $R_L = 60 \Omega$ ;  $V_{INH} < V_{INH,ON}$ ;  $-40 \text{ }^\circ\text{C} < T_j < 125 \text{ }^\circ\text{C}$ ; all voltages with respect to ground; positive current flowing into pin; unless otherwise specified.

Parameter	Symbol	Limit Values			Unit	Remarks
		Min.	Typ.	Max.		
<b>Dynamic CAN-Transceiver Characteristics</b>						
Propagation delay TxD-to-RxD LOW (recessive to dominant)	$t_{d(L),TR}$	–	150	280	ns	$C_L = 47 \text{ pF}$ ; $R_L = 60 \Omega$ ; $V_{CC} = 5 \text{ V}$ ; $C_{RxD} = 20 \text{ pF}$
Propagation delay TxD-to-RxD HIGH (dominant to recessive)	$t_{d(H),TR}$	–	150	280	ns	$C_L = 47 \text{ pF}$ ; $R_L = 60 \Omega$ ; $V_{CC} = 5 \text{ V}$ ; $C_{RxD} = 20 \text{ pF}$
Propagation delay TxD LOW to bus dominant	$t_{d(L),T}$	–	100	140	ns	$C_L = 47 \text{ pF}$ ; $R_L = 60 \Omega$ ; $V_{CC} = 5 \text{ V}$
Propagation delay TxD HIGH to bus recessive	$t_{d(H),T}$	–	100	140	ns	$C_L = 47 \text{ pF}$ ; $R_L = 60 \Omega$ ; $V_{CC} = 5 \text{ V}$
Propagation delay bus dominant to RxD LOW	$t_{d(L),R}$	–	50	140	ns	$C_L = 47 \text{ pF}$ ; $R_L = 60 \Omega$ ; $V_{CC} = 5 \text{ V}$ ; $C_{RxD} = 20 \text{ pF}$
Propagation delay bus recessive to RxD HIGH	$t_{d(H),R}$	–	50	140	ns	$C_L = 47 \text{ pF}$ ; $R_L = 60 \Omega$ ; $V_{CC} = 5 \text{ V}$ ; $C_{RxD} = 20 \text{ pF}$

1)  $V_{diff} = V_{CANH} - V_{CANL}$

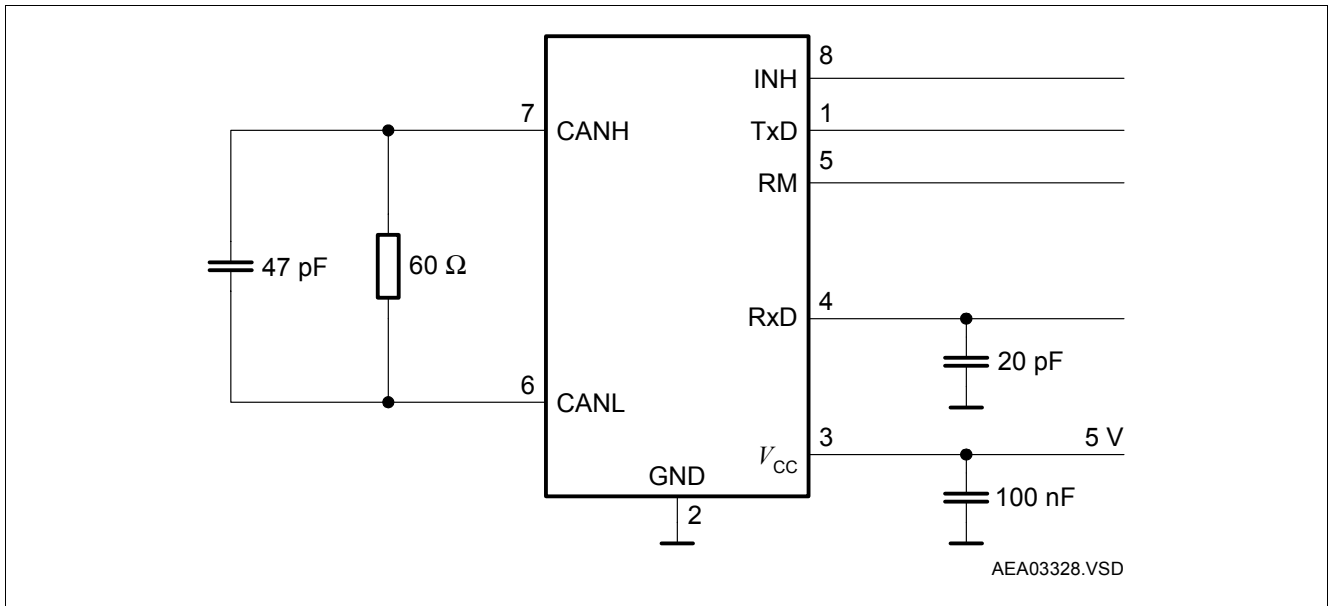

Figure 4 Test Circuit for Dynamic Characteristics

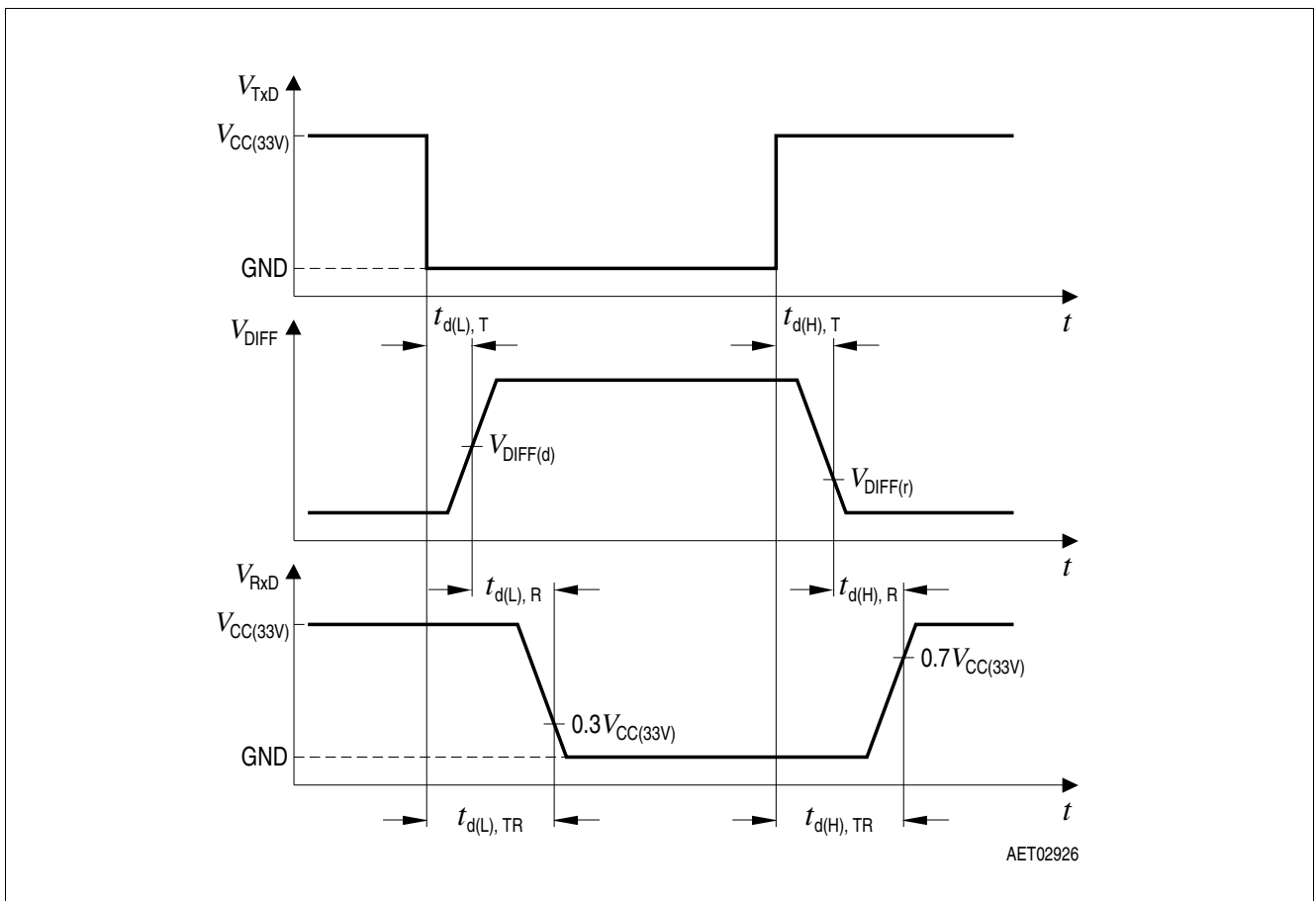

Figure 5 Timing Diagrams for Dynamic Characteristics

## 7 Application Information

Note: The following information is given as a hint for the implementation of the device only and shall not be regarded as a description or warranty of a certain functionality, condition or quality of the device.

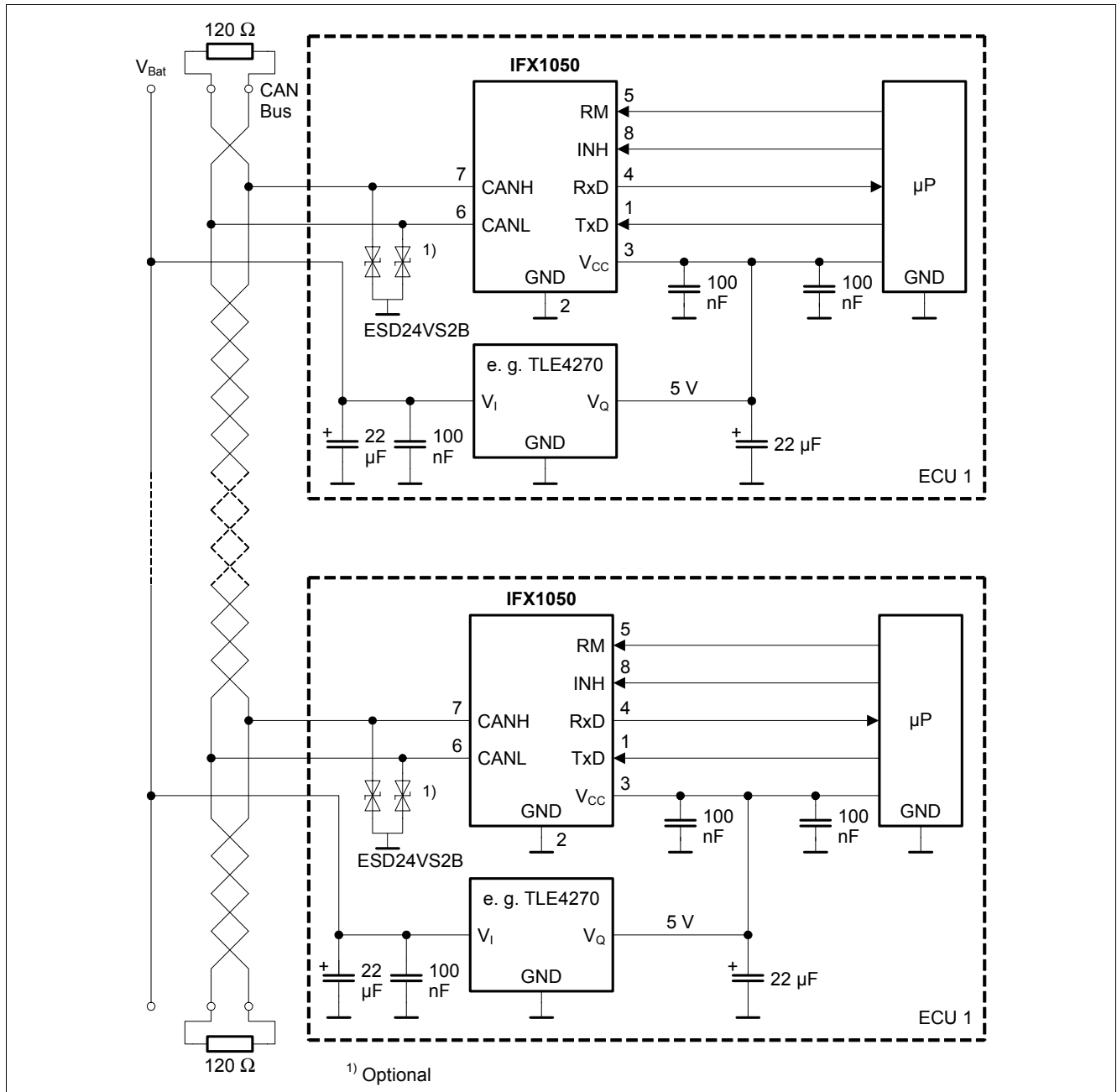

Figure 6 Mode State Diagram

Note: This is a very simplified example of an application circuit. The function must be verified in the real application.

### 7.1 Further Application Information

- Please contact us for information regarding the Pin FMEA.
- Existing App. Note
- For further information you may contact <http://www.infineon.com/>

## 8 Package Outlines

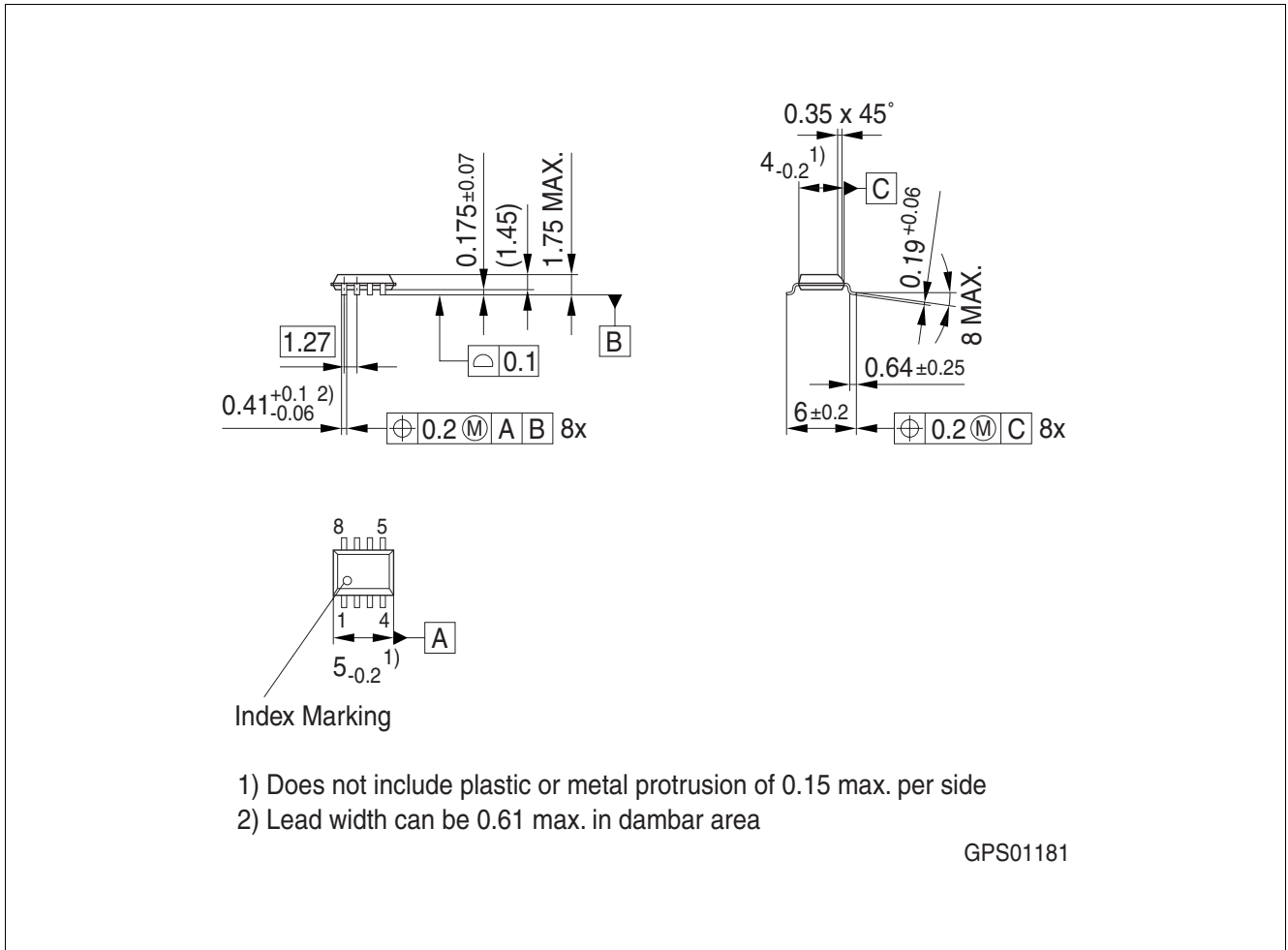

Figure 7 PG-DSO-8 (PG-DSO-8-16)

### Green Product (RoHS compliant)

To meet the world-wide customer requirements for environmentally friendly products and to be compliant with government regulations the device is available as a green product. Green products are RoHS-Compliant (i.e. Pb-free finish on leads and suitable for Pb-free soldering according to IPC/JEDEC J-STD-020).

## 9 Revision History

Revision	Date	Changes
1.0	2009-05-12	Initial data sheet

**Edition 2009-05-14**

**Published by  
Infineon Technologies AG  
81726 Munich, Germany**

**© 2009 Infineon Technologies AG  
All Rights Reserved.**

### **Legal Disclaimer**

The information given in this document shall in no event be regarded as a guarantee of conditions or characteristics. With respect to any examples or hints given herein, any typical values stated herein and/or any information regarding the application of the device, Infineon Technologies hereby disclaims any and all warranties and liabilities of any kind, including without limitation, warranties of non-infringement of intellectual property rights of any third party.

### **Information**

For further information on technology, delivery terms and conditions and prices, please contact the nearest Infineon Technologies Office ([www.infineon.com](http://www.infineon.com)).

### **Warnings**

Due to technical requirements, components may contain dangerous substances. For information on the types in question, please contact the nearest Infineon Technologies Office.

Infineon Technologies components may be used in life-support devices or systems only with the express written approval of Infineon Technologies, if a failure of such components can reasonably be expected to cause the failure of that life-support device or system or to affect the safety or effectiveness of that device or system. Life support devices or systems are intended to be implanted in the human body or to support and/or maintain and sustain and/or protect human life. If they fail, it is reasonable to assume that the health of the user or other persons may be endangered.