

JAN QUALIFIED

DG180-191

High-Speed Driver With JFET Switch

GENERAL DESCRIPTION

The DG180 thru DG191 series of analog gates consist of 2 or 4 N-channel junction-type field-effect transistors (JFET) designed to function as electronic switches. Level-shifting drivers enable low-level inputs (0.8 to 2V) to control the ON-OFF state of each switch. The driver is designed to provide a turn-off speed which is faster than turn-on speed, so that break-before-make action is achieved when switching from one channel to another. In the ON state, each switch conducts current equally well in both directions. In the OFF condition, the switches will block voltages up to 20V peak-to-peak. Switch-OFF input-output isolation is 50dB at 10MHz, due to the low output impedance of the FET-gate driving circuit.

ORDERING INFORMATION

Part Number	Type	r _{DS(on)} (Max)
DG180	Dual SPST	10
DG181	Dual SPST	30
DG182	Dual SPST	75
DG183	Dual DPST	10
DG184	Dual DPST	30
DG185	Dual DPST	75
DG186	SPDT	10
DG187	SPDT	30
DG188	SPDT	75
DG189	Dual SPDT	10
DG190	Dual SPDT	30
DG191	Dual SPDT	75

FEATURES

- Constant ON-Resistance for Signals to ±10V (DG182, 185, 188, 191), to ±7.5V (All Devices)
- ±15V Power Supplies
- <2nA Leakage From Signal Channel in Both ON and OFF States
- TTL, DTL, RTL Direct Drive Compatibility
- t_{on}, t_{off} < 150ns, Break-Before-Make Action
- Cross-talk and Open Switch Isolation > 50dB at 10MHz (75Ω Load)
- JAN 38510 Approved

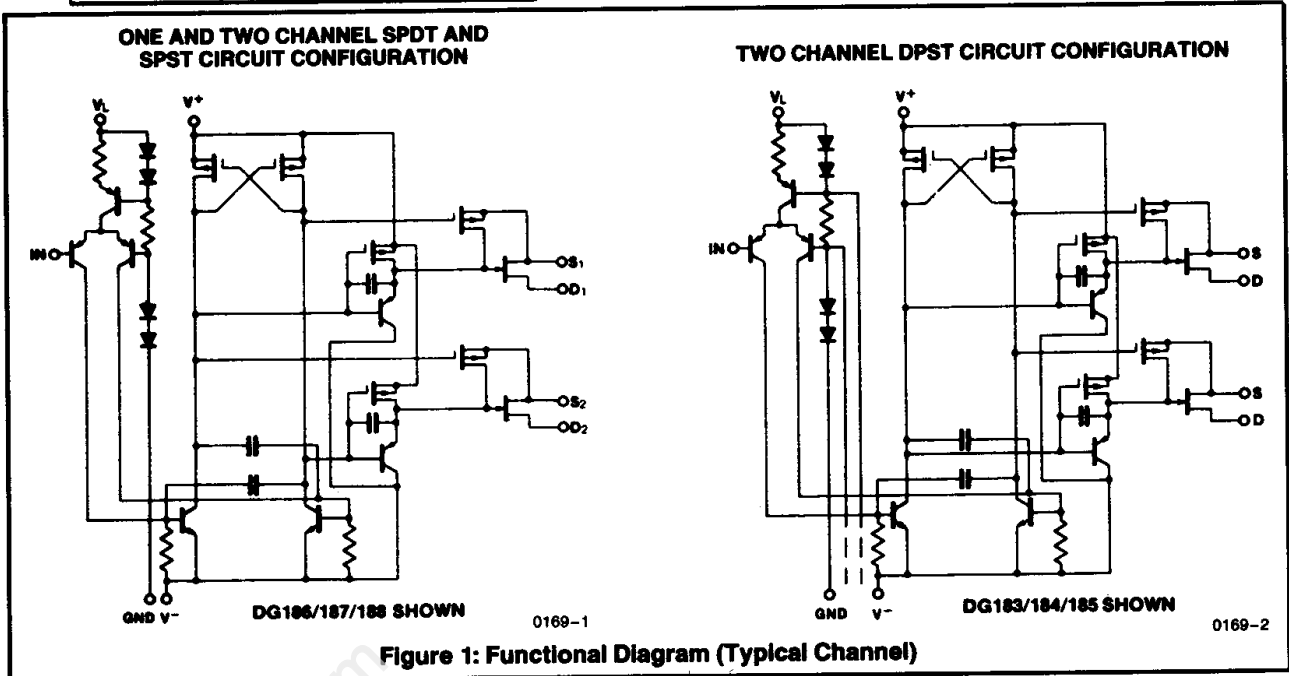
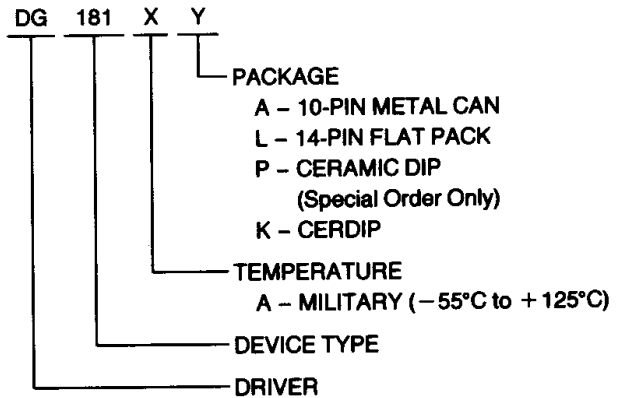

DG180-191

ABSOLUTE MAXIMUM RATINGS

$V^+ - V^-$	36V	$GND - V^-$	27V
$V^+ - V_D$	33V	$GND - V_{IN}$	20V
$V_D - V^-$	33V	Current (S or D) See Note 3	200mA
$V_D - V_S$	$\pm 22V$	Storage Temperature	$-65^\circ C$ to $+150^\circ C$
$V_L - V^-$	36V	Operating Temperature	$-55^\circ C$ to $+125^\circ C$
$V_L - V_{IN}$	8V	Power Dissipation*	450 (TW), 750 (FLAT), 825 (DIP) mW
$V_L - GND$	8V	Lead Temperature (Soldering, 10sec)	$300^\circ C$
$V_{IN} - GND$	8V		

*Device mounted with all leads welded or soldered to PC board. Derate 6mW/ $^\circ C$ (TW); 10mW/ $^\circ C$ (FLAT); 11mW/ $^\circ C$ (DIP) above 75 $^\circ C$.

NOTE: Stresses above those listed under "Absolute Maximum Ratings" may cause permanent damage to the device. These are stress ratings only and functional operation of the device at these or any other conditions above those indicated in the operational sections of the specifications is not implied. Exposure to absolute maximum rating conditions for extended periods may affect device reliability.

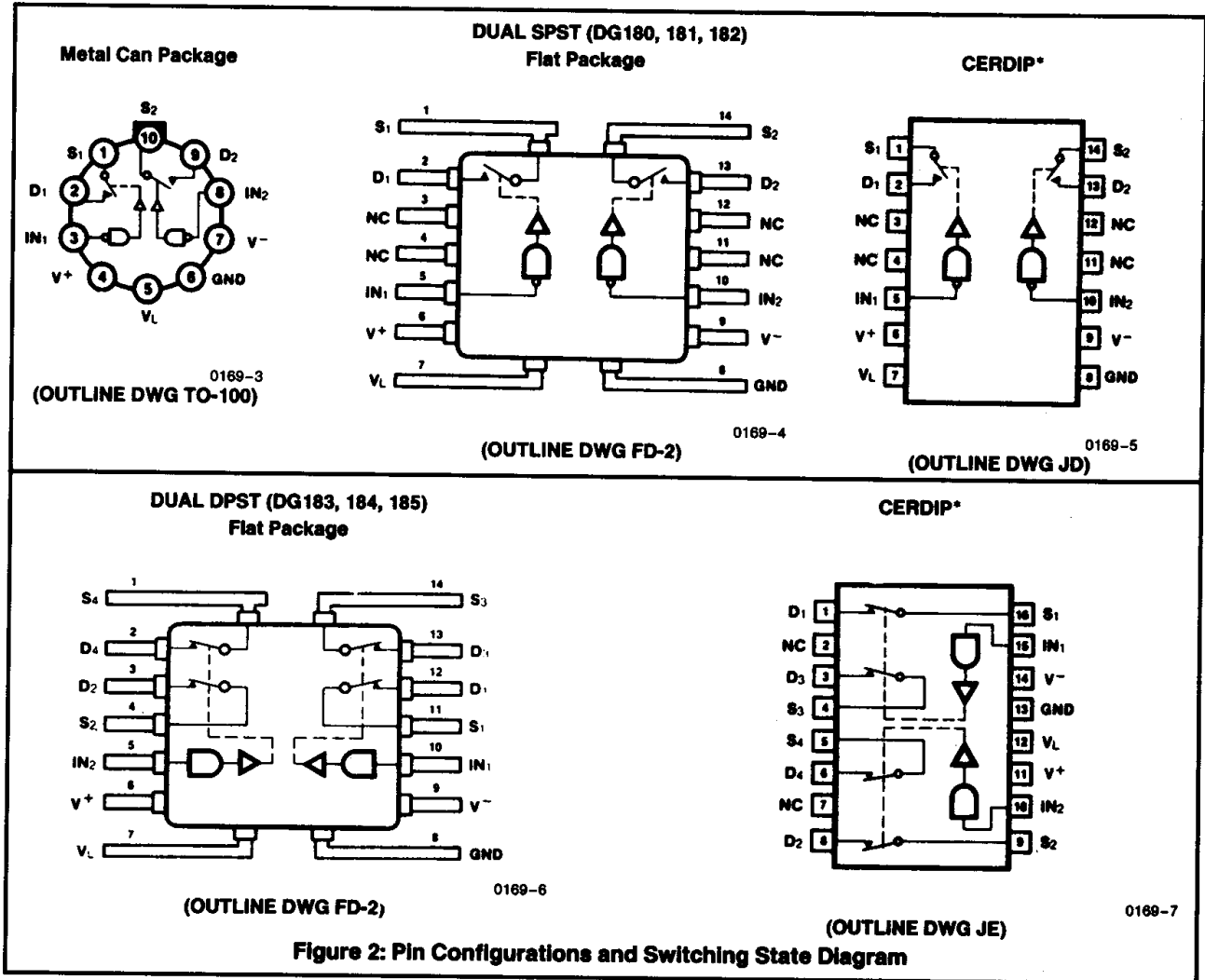

DG180-191

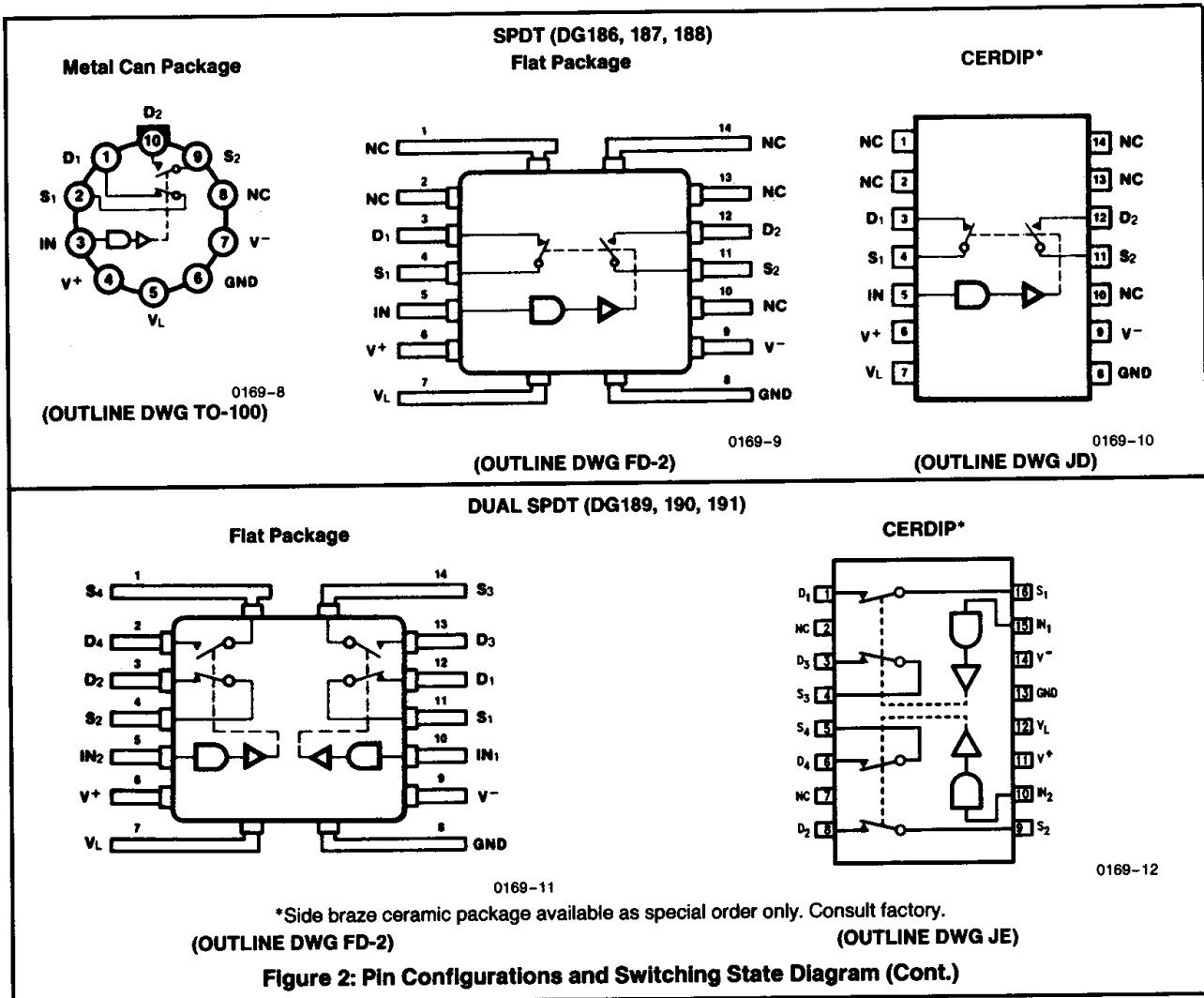

Figure 2: Pin Configurations and Switching State Diagram (Cont.)

ELECTRICAL CHARACTERISTICS (V⁺ = +15V, V⁻ = -15V, V_L = 5V, Unless Noted)

Parameter	Device No.	Test Conditions (Note 1)	A Series			Units
			-55°C	+25°C	+125°C	
SWITCH						
I _{S(off)}	DG181, 182, 184, 185 187, 188, 190, 191 (DG180, 183, 186, 189)	V _S = 10V, V _D = -10V, V ⁺ = 10V V ⁻ = -20V, V _{IN} = "OFF"		±1 ±(10)	100 (1000)	nA
	DG181, 184, 187, 190 (DG180, 183, 186, 189)	V _S = 7.5V, V _D = -7.5V V _{IN} = "OFF"		±1 ±(10)	100 (1000)	nA
	DG182, 185, 188, 191	V _S = 10V, V _D = -10V V _{IN} = "OFF"		±1	100	nA
I _{D(off)}	DG181, 182, 184, 185 187, 188, 190, 191 (DG180, 183, 186, 189)	V _S = 10V, V _D = -10V, V ⁺ = 10V V ⁻ = -20V, V _{IN} = "OFF"		±1 ±(10)	100 (1000)	nA
	DG181, 184, 187, 190 (DG180, 183, 186, 189)	V _S = 7.5V, V _D = -7.5V V _{IN} = "OFF"		±1 ±(10)	100 (1000)	nA
	DG182, 185, 188, 191	V _S = 10V, V _D = -10V V _{IN} = "OFF"		±1	100	nA

DG180-191

ELECTRICAL CHARACTERISTICS (V⁺ = +15V, V⁻ = -15V, V_L = 5V, Unless Noted) (Continued)

Parameter	Device No.	Test Conditions (Note 1)	A Series			Units		
			-55°C	+25°C	+125°C			
SWITCH (Continued)								
I _{D(on)} + I _{S(on)}	DG180, 181, 183, 184 186, 187, 189, 190	V _D = V _S = -7.5V, V _{IN} = "ON"		±2	-200	nA		
	DG182, 185, 188, 191	V _D = V _S = -10V, V _{IN} = "ON"		±2	-200	nA		
INPUT								
I _{INL}	ALL	V _{IN} = 0V	-250	-250	-250	μA		
I _{INH}	ALL	V _{IN} = 5V		10	20	μA		
DYNAMIC								
t _{on}	10Ω Switches	See switching time test circuit		300		ns		
	30Ω Switches			150				
	75Ω Switches			250				
t _{off}	10Ω Switches			250				
	30Ω and 75Ω Switches			130				
	C _{S(off)}		DG181, 182, 184, 185, 187, 188, 190, 191 (DG180, 183, 186, 189)	V _S = -5V, I _D = 0, f = 1MHz	9 typical (21 typical)		pF	
C _{D(off)}		V _D = +5V, I _S = 0, f = 1MHz	6 typical (17 typical)					
C _{D(on)} + C _{S(on)}		V _D = V _S = 0, f = 1MHz	14 typical (17 typical)					
OFF Isolation		R _L = 75Ω, C _L = 3pF	Typically > 50dB at 10MHz (See Note 2)					
SUPPLY								
I ⁺	DG180, 181, 182, 189 190, 191	V _{IN} = 5V		1.5		mA		
	DG183, 184, 185			0.1				
	DG186, 187, 188			0.8				
I ⁻	DG180, 181, 182, 189 190, 191			-5.0				
	DG183, 184, 185			-4.0				
	DG186, 187, 188			-3.0				
I _L	DG180, 181, 182, 183 184, 185, 189, 190, 191			4.5				
	DG186, 187, 188			3.2				
I _{GND}	ALL			-2.0				
I ⁺	DG180, 181, 182, 189 190, 191		V _{IN} = 0V		1.5			mA
	DG183, 184, 185				3.0			
	DG186, 187, 188				0.8			
I ⁻	DG180, 181, 182, 189 190, 191			-5.0				
	DG183, 184, 185			-5.5				
	DG186, 187, 188			-3.0				
I _L	DG180, 181, 182, 183 184, 185, 189, 190, 191			4.5				
	DG186, 187, 188			3.2				
I _{GND}	ALL			-2.0				

NOTES 1. See Switching State Diagrams for V_{IN} "ON" and V_{IN} "OFF" Test Conditions.

2. Off Isolation typically > 55dB at 1MHz for DG180, 183, 186, 189.

3. Saturation Drain Current for DG180, 183, 186, 189 only, typically 300mA (2ms Pulse Duration). Maximum Current on all other devices (any terminal) 30mA.

ELECTRICAL CHARACTERISTICS (Continued) MAXIMUM RESISTANCES ($r_{DS(ON)}$ MAX)

Device Number	Conditions (Note 1) $V^+ = 15V, V^- = -15V,$ $V_L = 5V$	Military Temperature			Units $V_L = 5V$
		-55°C	+25°C	+125°C	
DG180	$V_D = -7.5V$	10	10	20	Ω
DG181	$V_D = -7.5V$	30	30	60	Ω
DG182	$V_D = -10V$	75	75	100	Ω
DG183	$V_D = -7.5V$	10	10	20	Ω
DG184	$V_D = -7.5V$	30	30	60	Ω
DG185	$V_D = -10V$	75	75	150	Ω
DG186	$V_D = -7.5V$	10	10	20	Ω
DG187	$V_D = -7.5V$	30	30	60	Ω
DG188	$V_D = -10V$	75	75	150	Ω
DG189	$V_D = -7.5V$	10	10	20	Ω
DG190	$V_D = -7.5V$	30	30	60	Ω
DG191	$V_D = -10V$	75	75	150	Ω

APPLICATION HINT (for design only): Normally the minimum signal handling capability of the DG180 through DG191 family is 20V peak-to-peak for the 75 Ω switches and 15V peak-to-peak for the 10 Ω and 30 Ω (refer I_D and I_S tests above). For other Analog Signals, the following guidelines can be used: proper switch turn-off requires that $V^- \leq V_{ANALOG(peak)} - V_p$ where $V_p = 7.5V$ for the 10 Ω AND 30 Ω switches and $V_p = 5.0V$ for 75 Ω switches e.g., -10V minimum (-peak) analog signal and a 75 Ω switch ($V_p = 5V$), requires that $V^- \leq -10V - 5V = -15V$.

Logic Input for "OFF" to "ON" Condition (DG180/181/182 Shown)

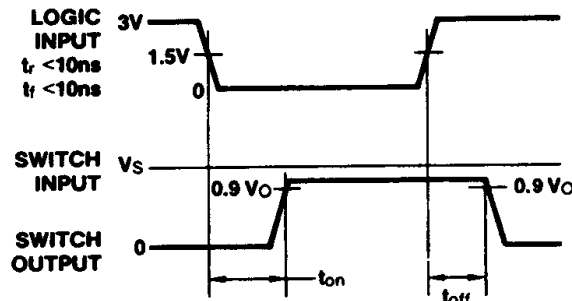

0169-13

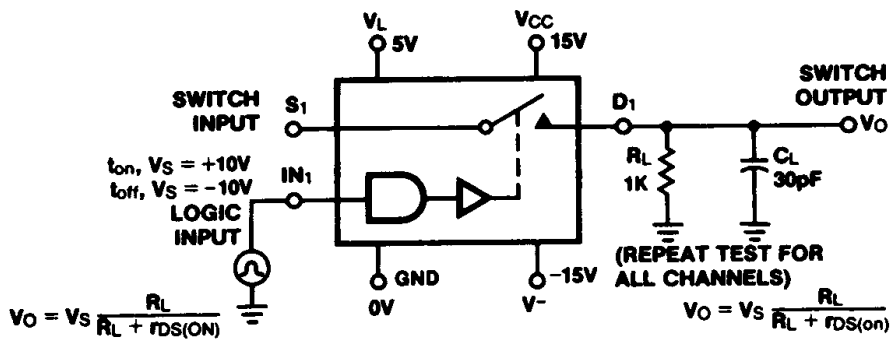

0169-14

Figure 3: Switching Time Test Circuits

Switch output waveform shown for $V_S = \text{constant}$ with logic input waveform as shown. Note that V_S may be + or - as per switching time test circuit. V_O is the steady state output with switch on. Feedthrough via gate capacitance may result in spikes at leading and trailing edge of output waveform.

DG180-191**DUAL SPST – DG180/181/182****TEST CONDITIONS**

DG180/181/182	
V_{IN} "ON" = 0.8V	All Channels
V_{IN} "OFF" = 2.0V	All Channels

SWITCH STATES ARE
FOR LOGIC "1" INPUT = 2.0V

SPDT – DG186/187/188**TEST CONDITIONS**

DG186/187/188	
V_{IN} "ON" = 2.0V	Channel 1
V_{IN} "ON" = 0.8V	Channel 2
V_{IN} "OFF" = 2.0V	Channel 2
V_{IN} "OFF" = 0.8V	Channel 1

SWITCH STATES ARE
FOR LOGIC "1" INPUT = 2.0V

DUAL DPST – DG183/184/185**TEST CONDITIONS**

DG183/184/185	
V_{IN} "ON" = 2.0V	All Channels
V_{IN} "OFF" = 0.8V	All Channels

SWITCH STATES ARE
FOR LOGIC "1" INPUT = 2.0V

DUAL SPDT – DG189/190/191**TEST CONDITIONS**

DG189/190/191	
V_{IN} "ON" = 2.0V	Channels 1 & 2
V_{IN} "ON" = 0.8V	Channels 3 & 4
V_{IN} "OFF" = 2.0V	Channels 3 & 4
V_{IN} "OFF" = 0.8V	Channels 1 & 2

SWITCH STATES ARE
FOR LOGIC "1" INPUT = 2.0V