

UI Platform

IK6207TQ-ER

Description

IK6207TQ-ER has a C8052 devices. It is fully integrated mixed-signal system-on-a-chip MCUs. The IK6207TQ-ER utilizes CORERIVER ' TouchCore 380 microcontroller core.

The IK6207TQ-ER are cathode-grid LED display drives with output size - 4 digits x13 segments or 7 digits x 10 segments .

Features

- Operation voltage for digital part: 3.0V ~ 3.6V
- Operation voltage for output LEDs: 5.0V
- Operation Frequency : Max.48MHz
- 7-step individual dimming control for each grid
- LCD OSC: built in (with external resistor) 500kHz @ R=12.1kΩ
- Pulse segment current: 10mA @ VDD = 3.3V
- 11- channel Touch Sensing
 - Capacitive Type Touch & Digital Sensing
 - 16-bit level Resolution
- CPU
 - 8 bit Turbo 8052 Architecture
- Memory
 - 16kB Flash (Including 1kB User EEPROM)
 - 512B Internal Aux RAM
 - 256B Internal RAM
- 12 Bit Analog to Digital Converter
- Digital Peripherals
 - Up to 18 Port I/O
 - 3 general purpose 16 bit counter/timers
 - UART
 - SPI
 - I2C
 - Interrupt
- Power Save Modes
- Operation Temperature : -40 ~ 85°C

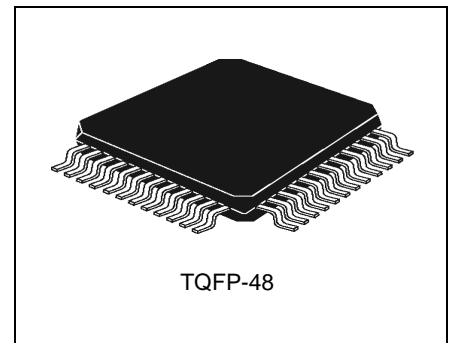

Device	Operating Temperature Range	Package
IK6207TQ-ER	T _A = -40° to 85° C	TQFP-48

Application

- Home Appliance : Washing machine, Refreegrator, Bidet, Air Conditioner

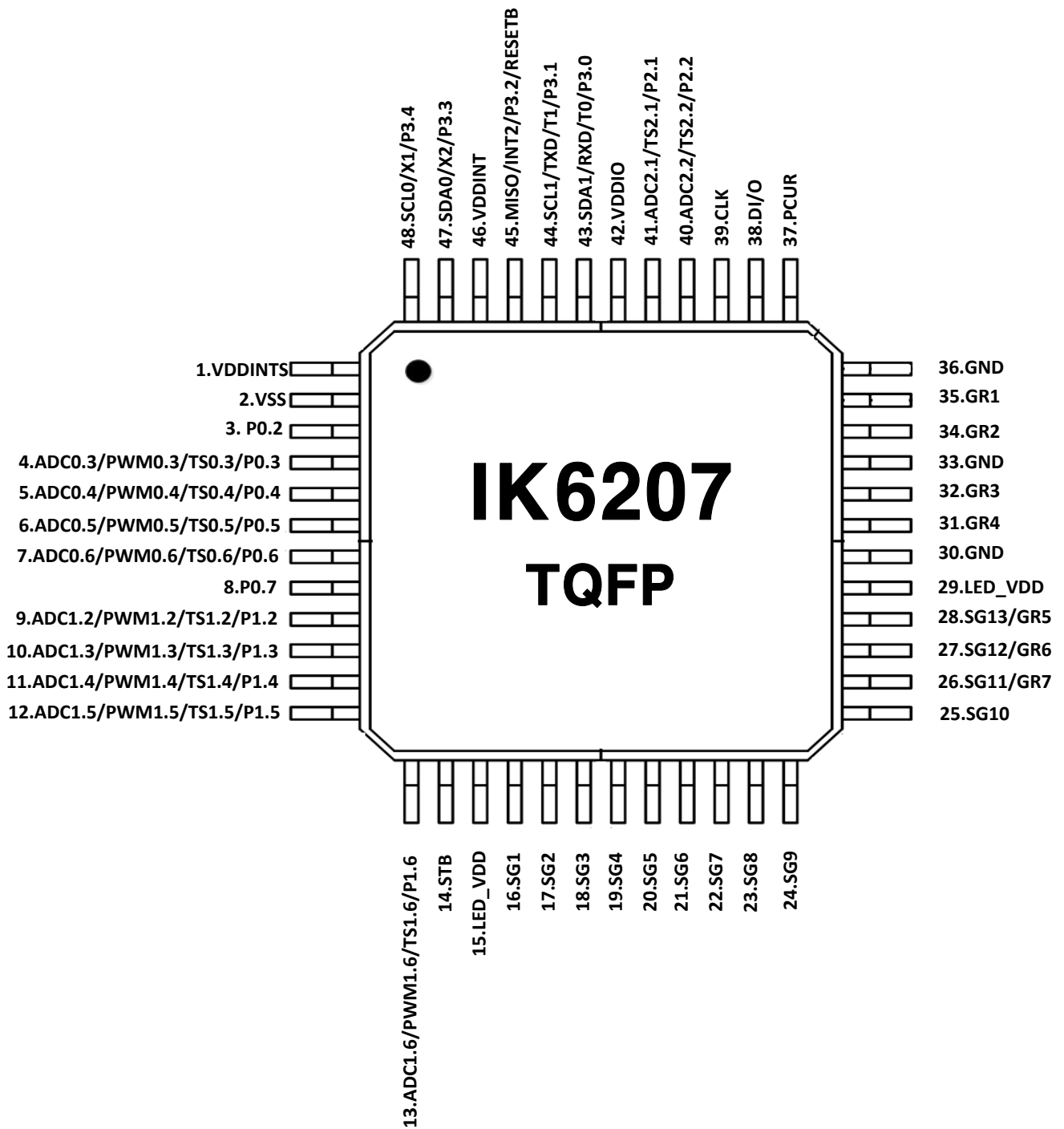

PIN DESCRIPTION

Pin Name	I/O	Description	Pin №
VDDIO	I	Digital I/O Power	42
VDDINT	O	Digital Power Input /Output (+ 1.8V)	46
VDDINITS	O	Touch Sensor Power Input / Output(+ 1.8V)	1
RESETB	I	External Reset(Active Low)	45
VSS	I	Digital Ground	2
XTAL1	I	Input to the inverting OSC	48
XTAL2	O	Output to the inverting OSC	47
I2C1_SDA/I2C2_SDA	I/O	Serial Data pin for ISP/MDS	43,47
I2C1_SCL/I2C2_SCL	I/O	Serial Data pin for ISP/MDS	44,48
TXD	O	Alternative UART Serial Port Output	44
RXD	I	Alternative UART Serial Port Output	43
P0[7:2]	I/O	<p>An 8-bit open-Drain or push-pull I/O port. Note that the output is fully driven (push-pull) when P0 drives PWM0 output.</p> <ul style="list-style-type: none"> • P0.2 open-Drain or push-pull I/O port. • P0.7 open-Drain or push-pull I/O port. • P0.3 PWM0.3 : PWM output 0.3 • P0.4 PWM0.4 : PWM output 0.4 • P0.5 PWM0.5 : PWM output 0.5 • P0.6 PWM0.6 : PWM output 0.6 • P0.3 ADC0.3 : A/D Converter Input 0.3 • P0.4 ADC0.4 : A/D Converter Input 0.4 • P0.5 ADC0.5 : A/D Converter Input 0.5 • P0.6 ADC0.6 : A/D Converter Input 0.6 • P0.3 TS0.3 : Touch Sensing channel 0.3 • P0.4 TS0.4 : Touch Sensing channel 0.4 • P0.5 TS0.5 : Touch Sensing channel 0.5 • P0.6 TS0.6 : Touch Sensing channel 0.6 	3,4,5,6, 7,8
P1[6:2]	I/O	<p>An 8-bit open-Drain or push-pull I/O port. Note that the output is fully driven (push-pull) when P1[3:2] drives PWM1[3:2] output.</p> <ul style="list-style-type: none"> • P1.2 PWM1.2 : PWM output 1.2 • P1.3 PWM1.3 : PWM output 1.3 • P1.4 PWM1.4 : PWM output 1.4 • P1.5 PWM1.5 : PWM output 1.5 • P1.6 PWM1.6 : PWM output 1.6 • P1.2 ADC1.2 : A/D Converter Input 1.2 • P1.3 ADC1.3 : A/D Converter Input 1.3 • P1.4 ADC1.4 : A/D Converter Input 1.4 • P1.5 ADC1.5 : A/D Converter Input 1.5 	9,10,11, 12,13

		<ul style="list-style-type: none"> • P1.6 ADC1.6 : A/D Converter Input 1.6 • P1.2 TS1.2 : Touch Sensing channel 1.2 • P1.3 TS1.3 : Touch Sensing channel 1.3 • P1.4 TS1.4 : Touch Sensing channel 1.4 • P1.5 TS1.5 : Touch Sensing channel 1.5 • P1.6 TS1.6 : Touch Sensing channel 1.6 	
P2[2:1]	I/O	<p>An 8-bit open-Drain or push-pull I/O port.</p> <ul style="list-style-type: none"> • P2.1 ADC2.1 : A/D Converter Input 2.1 • P2.2 ADC2.2 : A/D Converter Input 2.2 • P2.1 TS2.1 : Touch Sensing channel 2.1 • P2.2 TS2.2 : Touch Sensing channel 2.2 	40,41
P3[4:0]		<p>A 5-bit open-drain or push-pull I/O port. - Optional Pull-up Control Enable (Only P3[1:0])</p> <ul style="list-style-type: none"> • P3.0 I2C1_SDA : I2C Serial Data • P3.1 I2C1_SCL : I2C Serial Clock • P3.3 I2C0_SDA : I2C0 Serial Data • P3.4 I2C0_SCL : I2C0 Serial Clock • P3.0 SSB : SPI Slave Select Bar • P3.1 SCLK : SPI Serial Clock • P3.2 MISO : SPI Master Input Slave Output • P3.3 MOSI : SPI Master Output Slave Input • P3.0 RXD : UART Serial Port Input • P3.1 TXD : UART Serial Port Output • P3.0 INT0 : External Interrupt 0 (Positive/Negative Edge) • P3.1 INT1 : External Interrupt 1 (Positive/Negative Edge) • P3.2 INT2 : External Interrupt 1 (Positive/Negative Edge) • P3.3 INT3 : External Interrupt 3 (Positive/Negative Edge) • P3.4 INT4 : External Interrupt 4 (Positive/Negative Edge) 	43,44,45, 47,48
LED_VDD	-	LED Power Supply	15,29
GND	-	Ground Pin	30,36
PUCR	I	A resistor is connected to this pin to determine the output currents and oscillation frequency.	37
DI/O	I/O	<p>Data Input /Output Pin This pin inputs serial data at the rising edge of the shift clock (starting from the bit)</p> <p>Data Output Pin – N channel Open Drain This pin outputs serial data at the falling edge of the shift clock</p>	38
CLK	I	<p>Clock Input Pin This pin reads serial data at the rising edge and output data at the falling edge.</p>	39
STB	I	<p>Serial Interface Strobe Pin The data input after the STB has fallen is processed as a command. When this pin is HIGH,CLK is ignores.</p>	14
SG1 to SG10	O	Segment output Pins (P-Channel, Open Drain)	16-25
SG11/GR6 to SG13/GR5	O	Segment / Grid Output Pins	26 - 28
GR1 to GR4	O	Grid Output Pins	31 - 35

BLOCK DIAGRAM

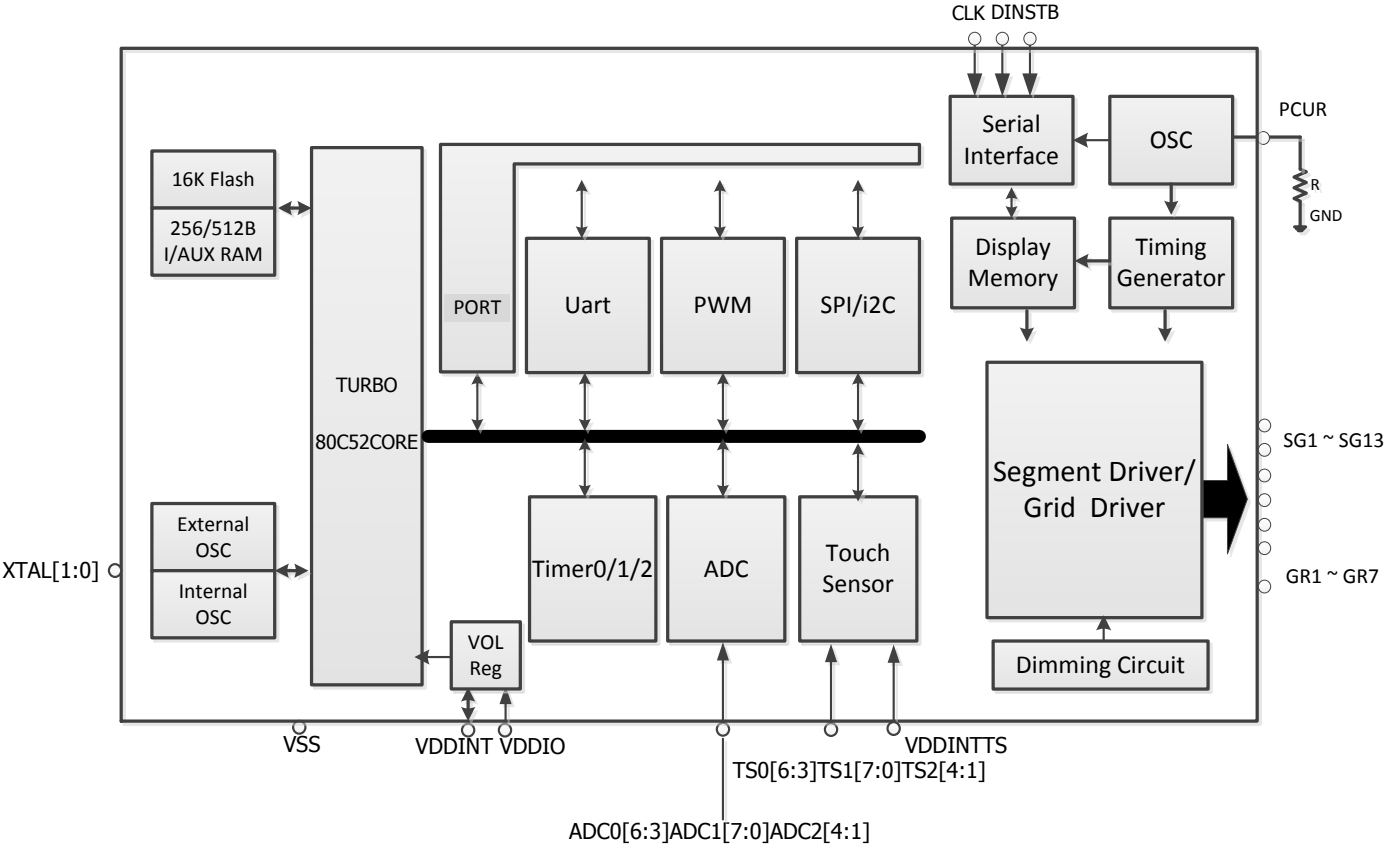

INPUT / OUTPUT CONFIGURATIONS

The schematic diagrams of the input and output circuits of the logic section are shown below.

◆ I/O Port : P0,P1,P2,P3

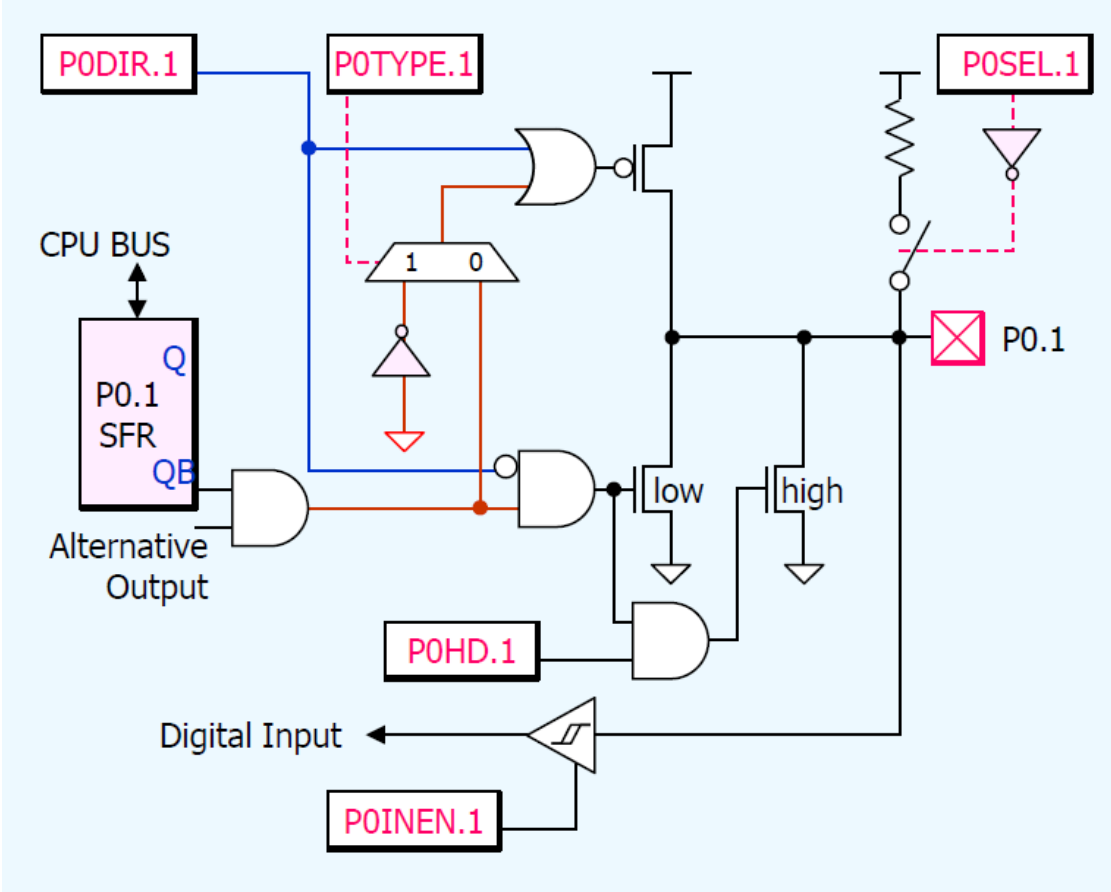

◆ Output Pins : GR1 to GR4

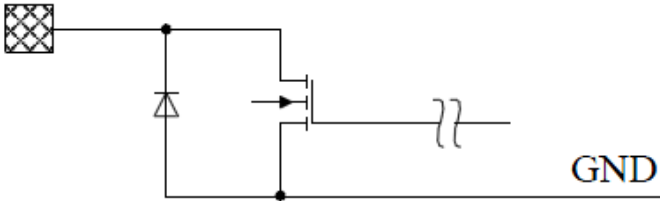

◆ Output Pins : SG2 to SG10

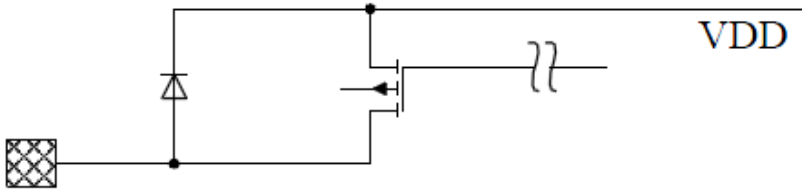

◆ Output Pins : SG12/GR5 to SG13/GR6

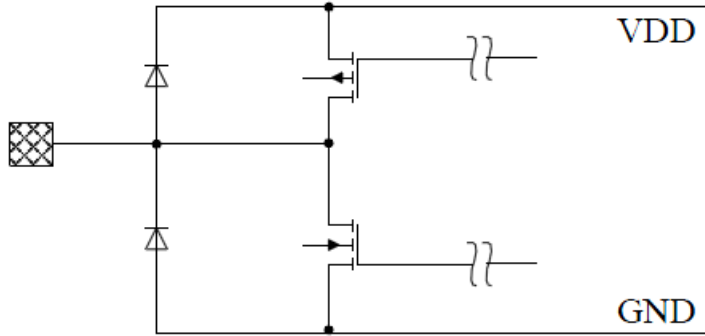

FUNCTIONAL DESCRIPTION

COMMANDS

A command is the first byte (b0 to b7) inputted to IK6207TQ-ER via DIN, DI/O Pin after STB Pin has changed From "HIGH" to "LOW" state. If for some reason the STB Pin is set "HIGH" while data or commands Are being transmitted, the serial communication is initialized, and the data/ commands being transmitted are considered invalid.

COMMAND 1: DISPLAY MODE SETTING COMMANDS

IK6207TQ-ER provides 4 display mode setting as shown in the diagram below: As stated earlier a command is the first one byte(b0 to b7) transmitted to IK6207TQ-ER via the DIN, DI/O Pin when STB is "LOW". However, for these commands, Bit 3 & Bit 8 (b2 to b7) are given a value of "0". The Display Mode Setting Commands determine the number of segments and grids be used (14 to 9 segments, 4 to 7 grids). A display command "ON" must be executed in order to resume display. If the same mode setting is selected, no command execution is take place, therefore, nothing happens. When Power is turned "ON", the mode 11 is selected.

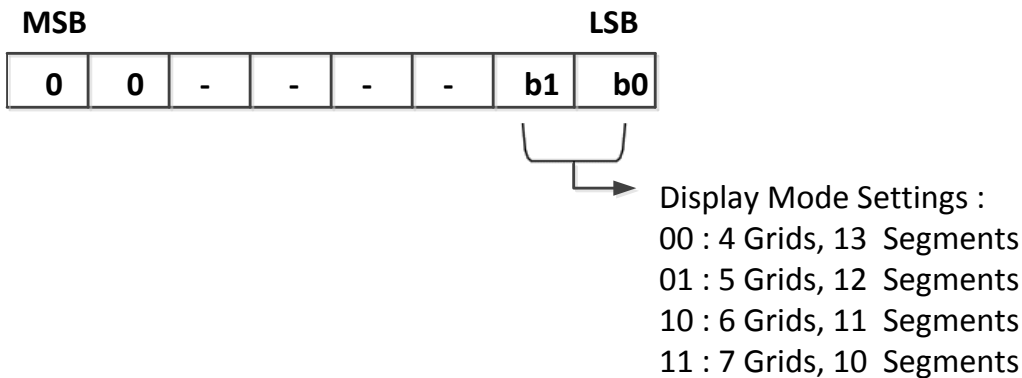

COMMAND 2: DATA SETTING COMMANDS

The Data Setting Commands executes the Data Write Mode for IK6207TQ-ER. The Data Setting Command, the bits5 and 6 (b4, b5) are given the value of "0". , bit7 (b6) is given the value of "1" while bit8 (b7) is given the value of "0". Please refer to the diagram below. When power is turned ON, bit 4 to bit 1 (b3 to b0) are given the value of "0".

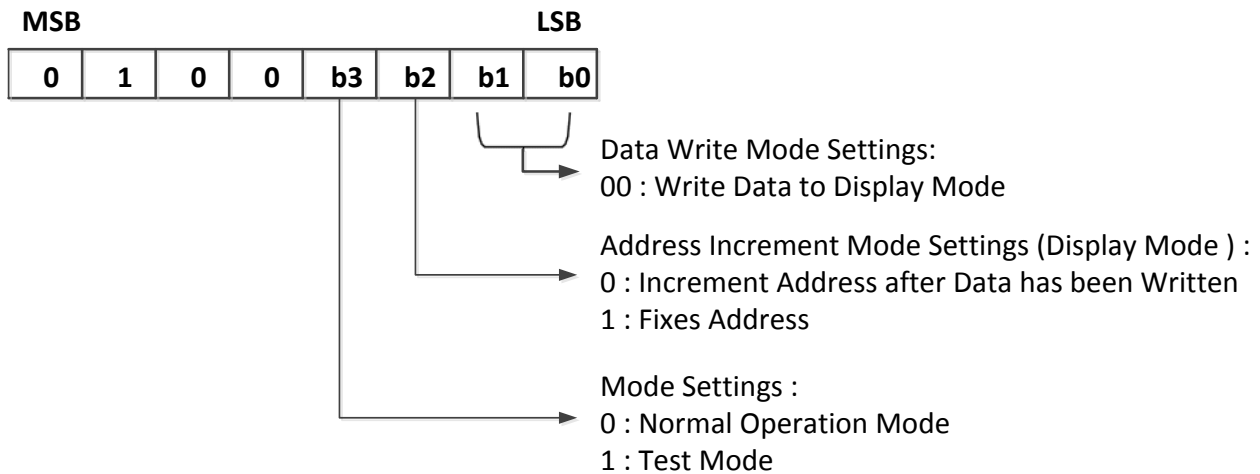

COMMAND 3: ADDRESS SETTING COMMANDS

Address Setting Commands are used to set the address of the display memory. The address is considered valid if it has a value of "00H" to "0DH". If the address is set to "0EH" or higher, the data is ignored until a valid address is set. When power is turned ON, the address is set at "00H". Please refer to the diagram below.

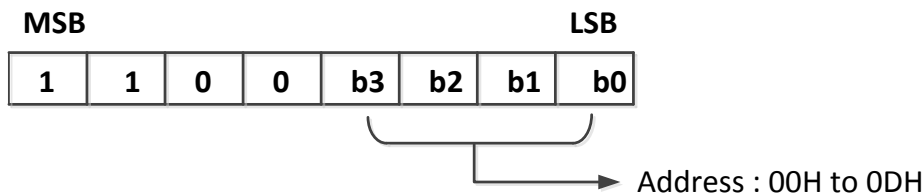

DISPLAY MODE AND RAM ADDRESS

Data transmitted from an external device to IK6207TQ-ER via the serial interface are stored in the Display RAM and are assigned addresses. The RAM Addresses of IK6207TQ-ER are given below in 8 bit unit.

	SG1	SG4	SG5	SG8	SG9	SG12
GR1	00H _L		00H _U			01H _L
GR2	02H _L		02H _U			03H _L
GR3	04H _L		04H _U			05H _L
GR4	06H _L		06H _U			07H _L
GR5	08H _L		08H _U			09H _L
GR6	0AH _L		0AH _U			0BH _L
GR7	0CH _L		0CH _U			0DH _L

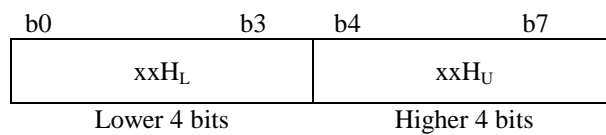

COMMAND 4 : DISPLAY CONTROL COMMANDS

The Display Control Commands are used to turn ON or OFF a display. It also used to set the pulse width. Please refer to the diagram below. When the power is turned ON, a 1/16 pulse width is selected and the displayed is turned OFF.

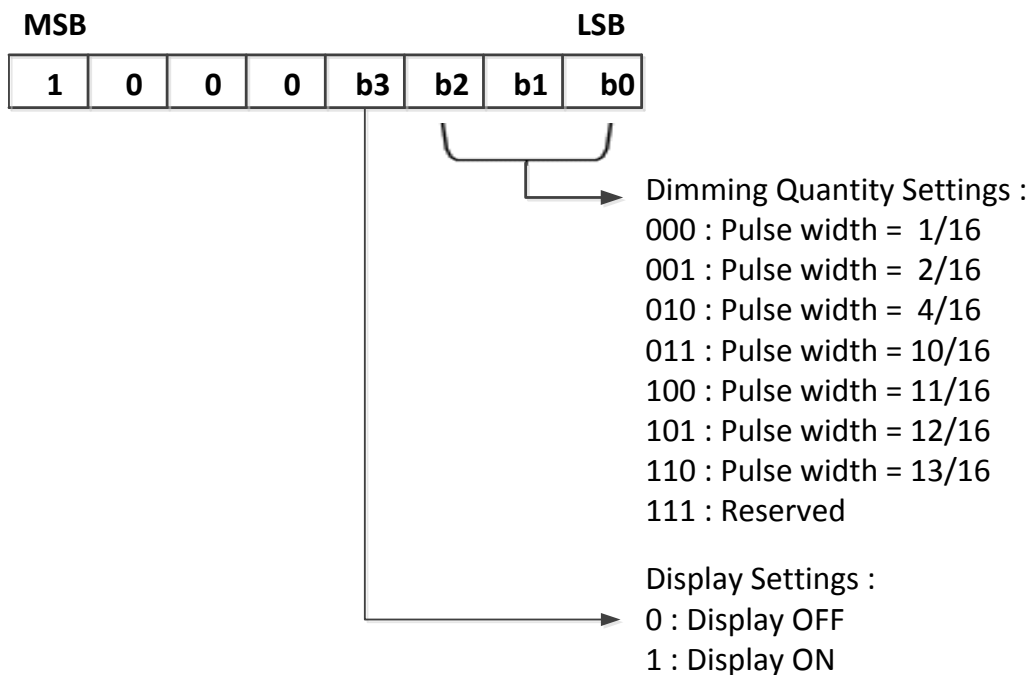

SCANNING AND DISPLAY TIMING

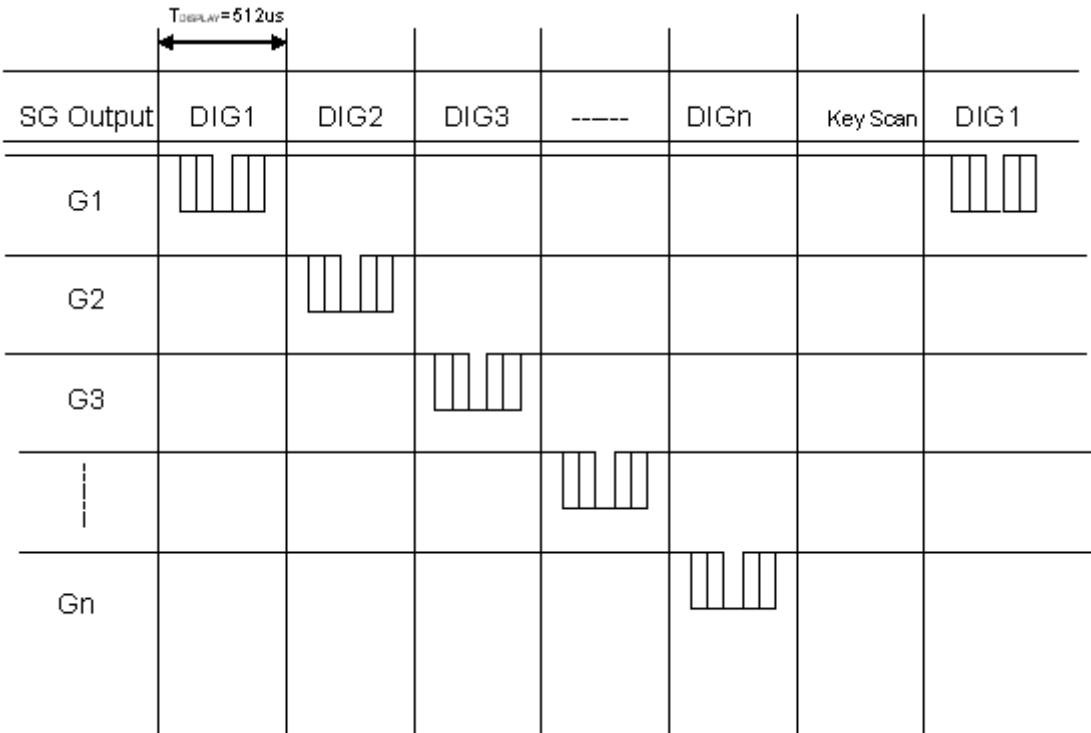

1 Frame = $T_{display} \times (n+1)$

SERIAL COMMUNICATION FORMAT

The following diagram shows the serial communication format.

RECEPTION (DATA/COMMAND WRITE)

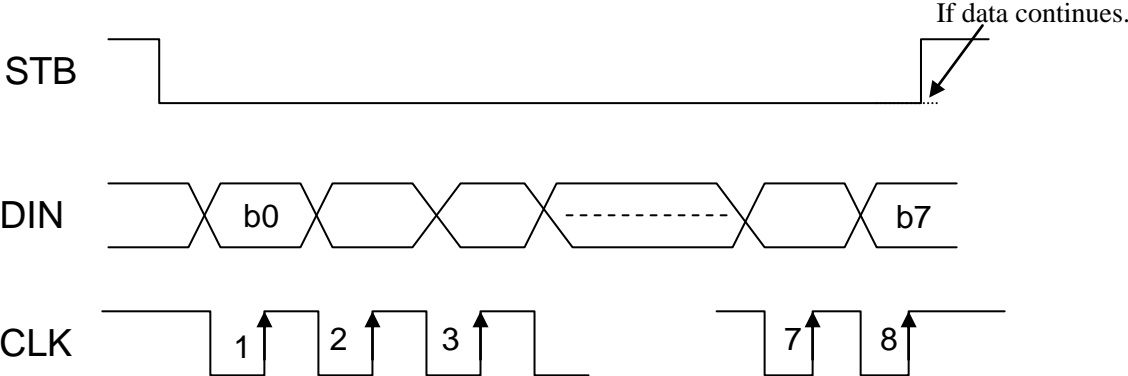

TRANSMISSION(DATA READ)

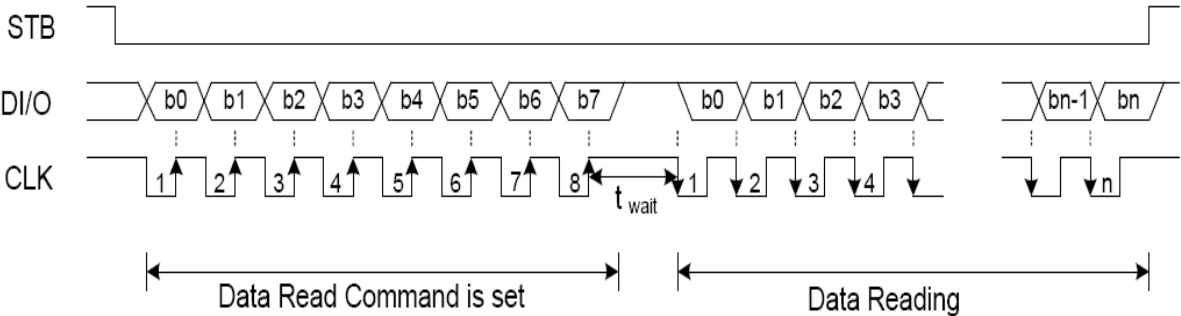

Where: t_{wait} (waiting time) $\geq 1\mu s$

SWITCHING CHARACTERISTIC WAVEFORM

Switching Characteristics Waveform is given below.

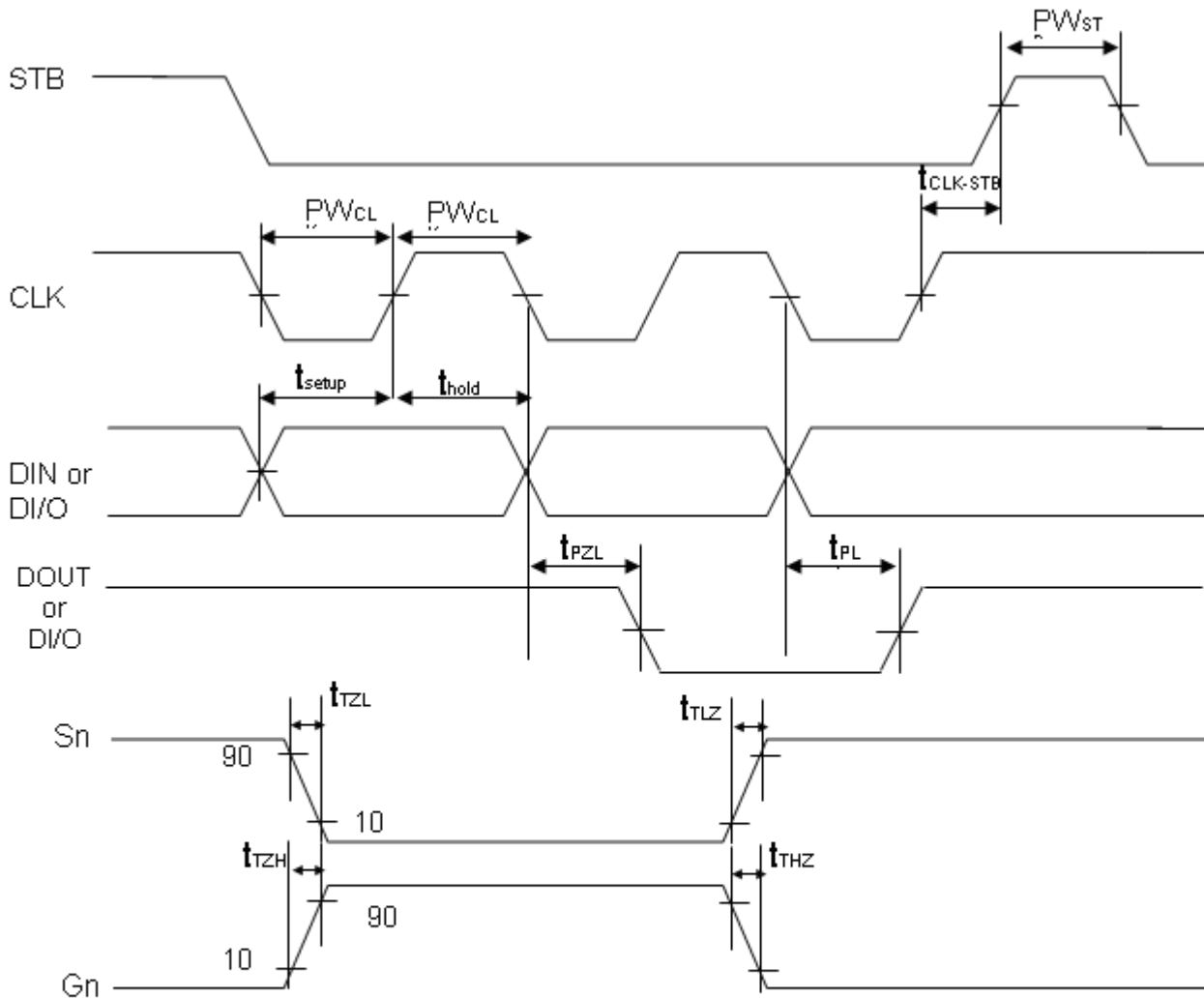

PW_{CLK} (Clock Pulse Width) $\geq 400ns$
 t_{setup} (Data Setup Time) $\geq 100ns$
 $t_{CLK-STB}$ (Clock - Strobe Time) $\geq 1\mu s$
 t_{TzH} (Rise Time) $\leq 1\mu s$
 $t_{TzL} < 1\mu s$

PW_{STB} (Strobe Pulse Width) $\geq 1\mu s$
 t_{hold} (Data Hold Time) $\geq 100ns$
 t_{TzH} (Fall Time) $\leq 10\mu s$
 f_{osc} = Oscillation Frequency
 $t_{TzL} < 10\mu s$

APPLICATIONS

Display memory is updated by incrementing addresses. Please refer to the following diagram.

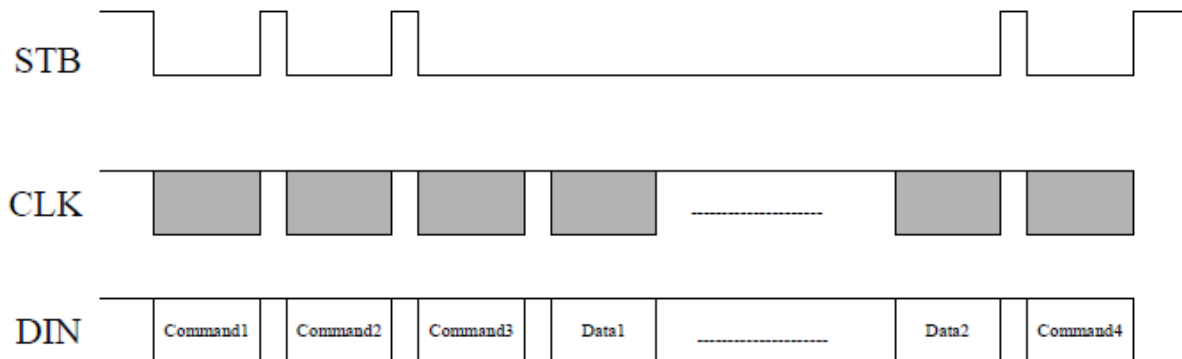

Where: Command 1: Display Mode Setting
 Command 2: Data Setting Command
 Command 3: Address Setting Command
 Data 1 to n : Transfer Display Data (14 Bytes max.)
 Command 4: Display Control Command

The following diagram shows the waveforms when updating specific addresses.

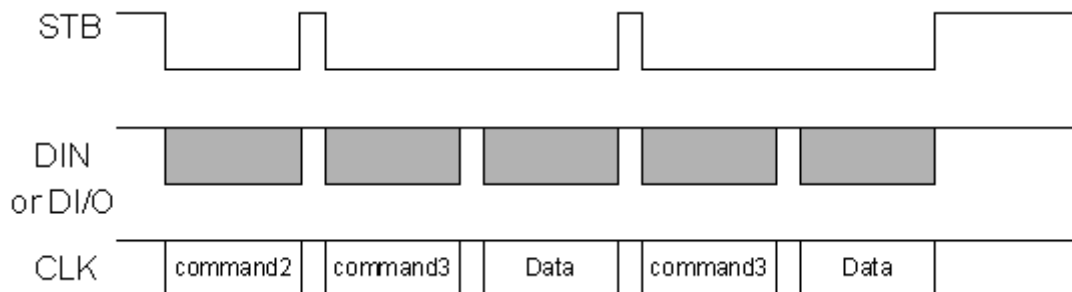

Where: Command 2 -- Data Setting Command
 Command 3 -- Address Setting Command
 Data -- Display Data

RECOMMENDED SOFTWARE PROGRAMMING FLOWCHART



- Note:
1. Command 1: Display Mode Setting
 2. Command 2: Data Setting Commands
 3. Command 3: Address Setting Commands
 4. Command 4 : Display control Commands
 5. When IC power is applied for the first time, the contents of the Display RAM are not defined: thus, it is strongly suggested that the contents of the Display RAM must be cleared during the initial setting.

POWER DISSIPATION CURVE

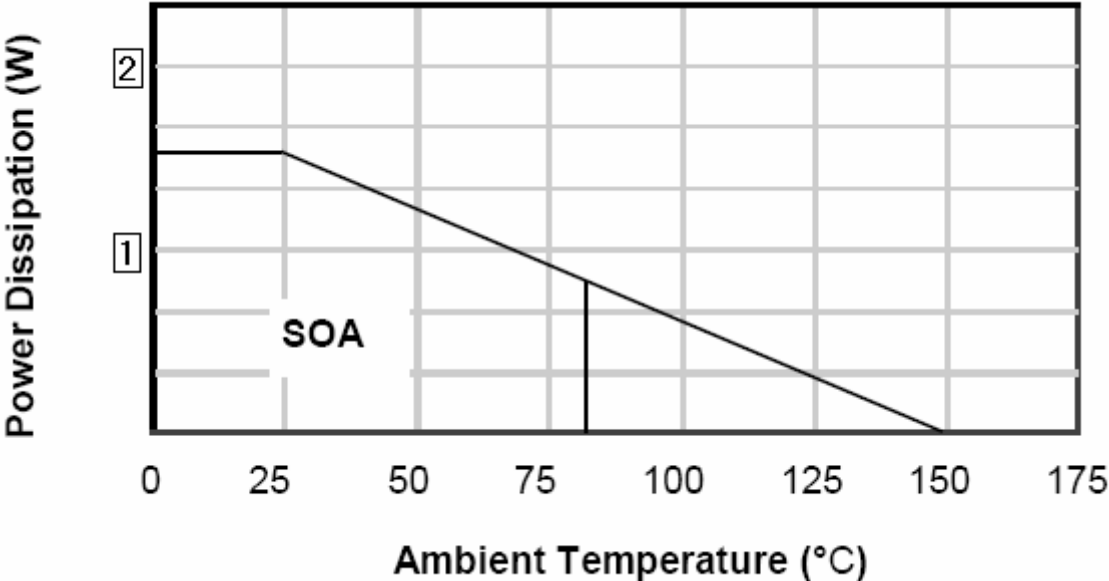

MCU ABSOLUTE MAXIMUM RATINGS

(Unless otherwise stated, Ta=25°C, GND=0V)

Parameter	Symbol	Rating	Units
Voltage on any pin relative to Ground	-	-0.5V to (V _{DDIO} + 0.5V)	V
Voltage in VDDIO relative to Ground	-	-0.5V to 3.6V	V
Output Voltage		-0.5V to (V _{DDIO} + 0.5V)	V
Output Current High	One I/O pin active	-25mA	mA
	All I/O pin active	-100mA	
Output Current Low	One I/O pin active	+30mA	mA
	All I/O active	+150mA	
Storage Temperature	-	-65°C to + 150°C	°C
Soldering Temperature	-	260°C, 10 seconds within 5°C of actual peak temperature	°C

*Stresses beyond those listed under “absolute maximum ratings” may cause permanent damage to the device. These are stress ratings only and functional operation of the device at these or any other conditions beyond those indicated under “recommended operating conditions” is not implied. Exposure to absolute-maximum-rated conditions for extended periods may affect device reliability

LED ABSOLUTE MAXIMUM RATINGS

(Unless otherwise stated, Ta=25°C, GND=0V)

Parameter	Symbol	Rating	Units
Supply Voltage	V_{DD}	-0.5 to +6.0	V
Logic Input Voltage	V_I	-0.5 to $V_{DD}+0.5$	V
Driver Output Current/Pin	I_{OHGR}	-24	mA
	I_{OLSG}	300	mA
Maximum Driver Output Current/Total	I_{TOTAL}	300	mA

*Stresses beyond those listed under “absolute maximum ratings” may cause permanent damage to the device. These are stress ratings only and functional operation of the device at these or any other conditions beyond those indicated under “recommended operating conditions” is not implied. Exposure to absolute-maximum-rated conditions for extended periods may affect device reliability

LED RECOMMENDED OPERATING RANGE

(Unless otherwise stated, Ta= -40 to +85°C, GND=0V)

Parameter	Symbol	Min	Typ	Max	Unit
Logic Supply Voltage	V_{DD}	3.0	3.3	5.5	V
Dynamic Current (see Note)	I_{DDdyn}	.	.	1	mA
High-Level Input Voltage	V_{IH}	$0.7V_{DD}$.	V_{DD}	V
Low-Level Input Voltage	V_{IL}	0	.	$0.3 V_{DD}$	V

Note : Test Condition : Set Display Control Commands = 80H (Display Turn OFF State)

MCU DC ELECTRICAL CHARACTERISTICS

 TA = -40 °C to +125 °C, V_{DDIO} = +2.7V to +3.6V unless otherwise specified.

Parameter	Symbol	Pin	Conditions	Value			Unit
				Min.	Typ.	Max.	
Input Low Voltage	V _{IL}	P0,P1,P2, P3	V _{DDIO} = +2.7V to +3.6V	-0.5	-	0.2V _{DDIO} +0.1	V
Input High Voltage	V _{IH}	P0,P1,P2, P3	V _{DDIO} = +2.7V to +3.6V	0.2V _{DDIO} +1.0	-	V _{DDIO} +0.5	V
Output Low Voltage	V _{OL}	P0,P1,P2, P3	V _{DDIO} = +3.0V to +3.6V (I _{OL} = 4.35mA) V _{DDIO} = +2.7V to +3.0V (I _{OL} = 3.35mA)	-	-	0.3V _{DDIO}	V
		P0,P1,P2, P3[1:0] (High Drive)	V _{DDIO} = +3.0V to +3.6V (I _{OL} = 34.79mA) V _{DDIO} = +2.7V to +3.0V (I _{OL} = 28.41mA)	-	-	0.3V _{DDIO}	V
Output High Voltage	V _{OH}	P0,P1,P2, P3	V _{DDIO} = +3.0V to +3.6V (I _{OH} = -8.04mA) V _{DDIO} = +2.7V to +3.0V (I _{OH} = -6.62mA)	0.7V _{DDIO}	-	-	V
	V _{OHP}	P0,P1,P2, P3 (Pull-up Resistor Only)	V _{DDIO} = +3.0V to +3.6V (I _{OHP} = -30.30uA) V _{DDIO} = +2.7V to +3.0V (I _{OHP} = -24.26uA)	0.7V _{DDIO}	-	-	V
Logical 1 to 0 Transition Current	I _{TL}	P0,P1,P2, P3	V _{DDIO} = 3.0V±10% (V _{IN} = +2.0V)		-	-650	uA
Input Leakage Current	I _{IL}	P0,P1,P2, P3	V _{IN} = V _{IH} or V _{IL}		-	±1	uA
Pin Capacitance	C _{IO}	All	V _{DDIO} = +3.0V		10	-	pF

LED ELECTRICAL CHARACTERISTICS

(Unless otherwise stated, V_{DD}=3.3~5.5V, GND=0V, T_a=-40 ~ 85°C)

Parameter	Symbol	Conditions	Value			Unit
			Min.	Typ.	Max.	
High-Level Output Current	I _{OHSG1}	(V _{DD} = 3.3 ~5.5V) V _{LED} =2.3V R = 12.1KOhm SG1 to SG11 SG12/GR7 to SG14/GR5	8	10	12	mA
	I _{OHSG2}	(V _{DD} = 5V) V _{LED} =2.3V R = 8.07KOhm SG1 to SG11 SG12/GR7 to SG14/GR5	12	15	18	
Digital Input Current	I _{DG}	-	-0.2	-	+0.2	uA
Low-Level Digital Output Current	I _{OLDG}	V _O = 0.4V	4	-	-	mA
Segment High-Level Output Current Tolerance	I _{TOLSG}	V _O = V _{DD} =2.3V R = 12.1KOhm SG1 TO SG11 SG12/GR7	-	-	±5	%
High-Level Input Voltage	V _{IH}	-	0.7V _{DD}	-	0.3V _{DD}	V
Low-Level Input Voltage	V _{IL}	-	-	-	0.3V _{DD}	V
Oscillation Frequency	f _{OSC1}	(V _{DD} =3.3 ~5.5V) R = 12.1kOhm	400	500	600	kHz
	f _{OSC2}	(V _{DD} = 5V) R = 8.07KOhm	500	750	900	

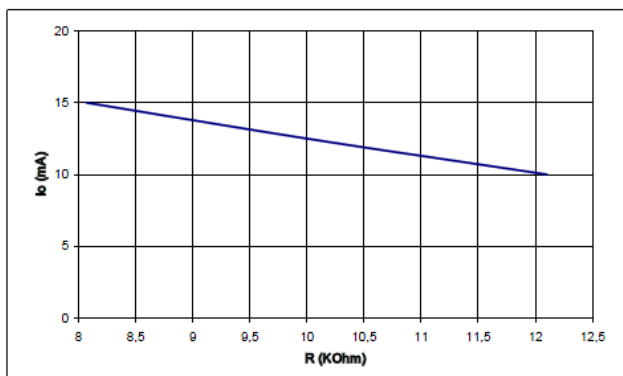

High-Level Output Current

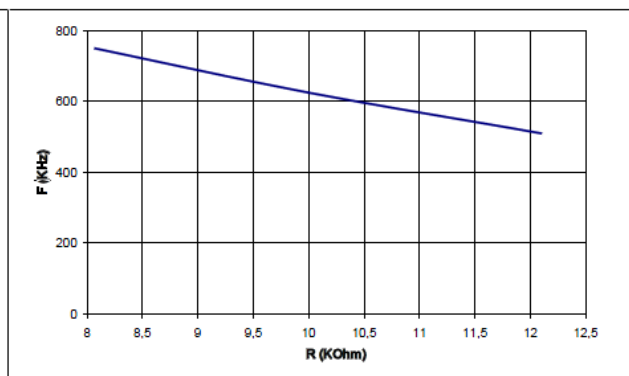

Oscillation Frequency

Remark : graphs are only V_{DD} = 5V

MCU AC ELECTRICAL CHARACTERISTICS

TA = -40 °C to +125 °C, V_{DDIO} = +2.7V to +3.6V unless otherwise specified.

Parameter	Symbol	Pin	Conditions	Value			Unit
				Min.	Typ.	Max.	
RESETB Input Width	t _{RST}	RESETB	V _{DDIO} =+3.0V to ± 10%	24	-	-	F _{SYS}
External Interrupt Input Width	t _{INT}	External Interrupt	V _{DDIO} =+3.0V to ± 10%	4	-	-	F _{SYS}

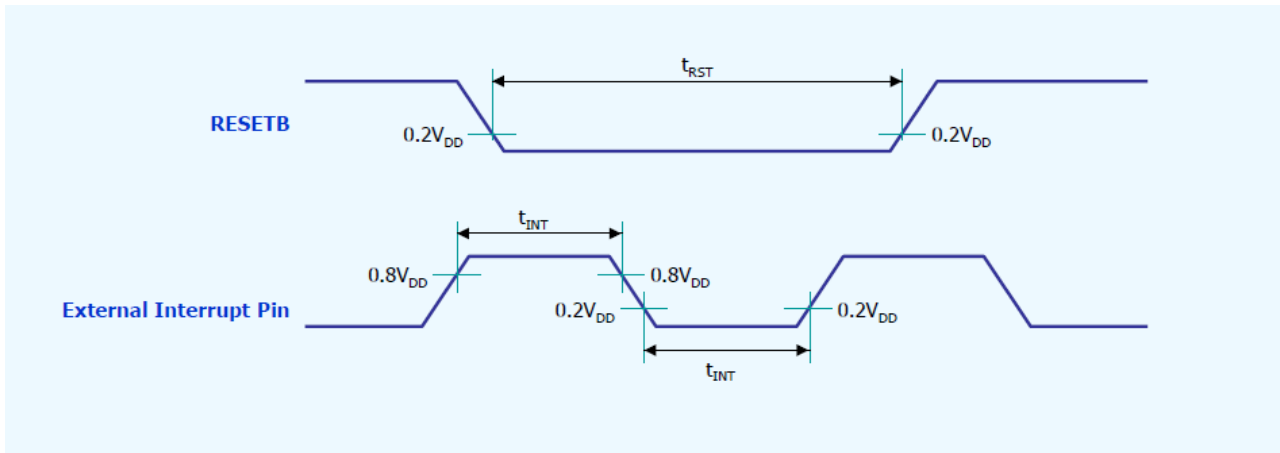

APPLICATION CIRCUIT

COMMON CATHODE TYPE LED PANEL

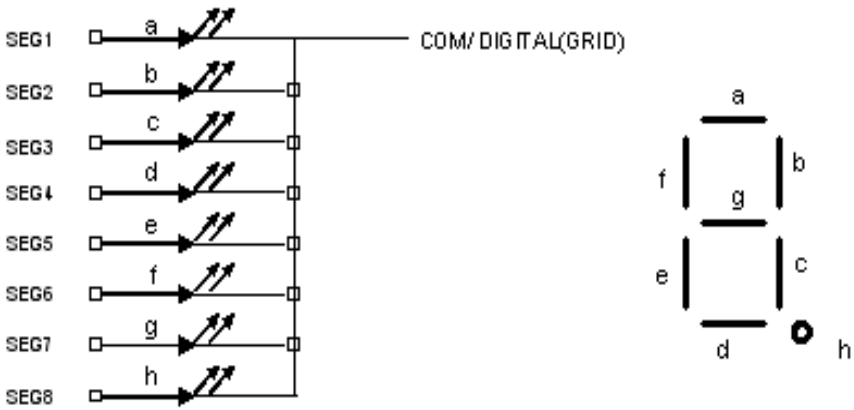

PACKAGE DIMENSION

TQFP-48

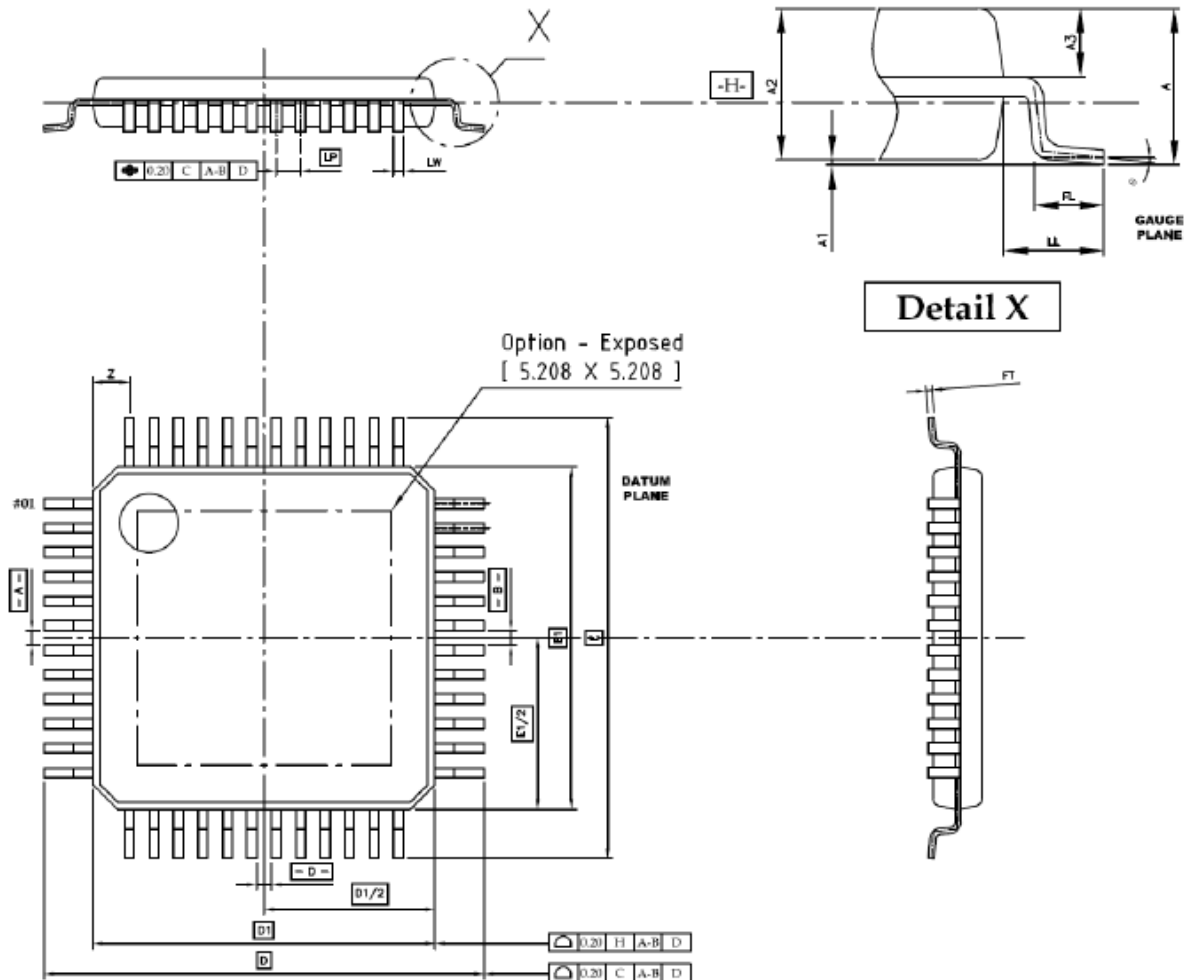

DIMENSIONS

Unit	D1	E1	D/E [TL]	FT	LP	LW	A max	A1	A2	A3	LL	FL	θ	Z
mm	7.10	7.10	9.20	0.127	0.50	0.25	1.20	0.15	1.05	(0.44)	1.00	0.75	8	0.75
	6.90	6.90	8.80	BSC		0.15		0.05	0.95			0.45	0	

NOTES

1. All Dimensions are in Millimeters
2. Dimensions Do Not include Burrs, Mole Flash, and Tie-bar Extrusions.
3. JEDEC References : MS-026