

1.0 A, 15 V, Step-Down Switching Regulator

IL2575-xx

The IL2575 series of regulators are monolithic integrated circuits ideally suited for easy and convenient design of a step-down switching regulator (buck converter). All circuits of this series are capable of driving a 1.0 A load with excellent line and load regulation. These devices are available in fixed output voltages of 3.3 V, 5.0 V, 12 V, 15 V, and an adjustable output version.

These regulators were designed to minimize the number of external components to simplify the power supply design. Standard series of inductors optimized for use with the IL2575 are offered by several different inductor manufacturers. Since the IL2575 converter is a switch-mode power supply, its efficiency is significantly higher in comparison with popular three-terminal linear regulators, especially with higher input voltages. In many cases, the power dissipated is so low that no heatsink is required or its size could be reduced dramatically.

A standard series of inductors optimized for use with the IL2575 are available from several different manufacturers. This feature greatly simplifies the design of switch-mode power supplies. The IL2575 features include a guaranteed $\pm 4\%$ tolerance on output voltage within specified input voltages and output load conditions, and $\pm 10\%$ on the oscillator frequency ($\pm 2\%$ over 0°C to 125°C). External shutdown is included, featuring $80\ \mu\text{A}$ (typical) standby current. The output switch includes cycle-by-cycle current limiting, as well as thermal shutdown for full protection under fault conditions.

ORDERING INFORMATION

IL2575Q	TO-220-5L
IL2575S	TO-220-5L
IL2575D2	TO-263-5L

$T_A = -40^\circ$ to $125^\circ\ \text{C}$ for all packages

Features

- 3.3 V, 5.0 V, 12 V, 15 V, and Adjustable Output Versions
- Adjustable Version Output Voltage Range, 1.23 to 37 V $\pm 4\%$ Maximum Over Line and Load Conditions
- Guaranteed 1.0 A Output Current
- Wide Input Voltage Range
- Requires Only 4 External Components
- 52 kHz Fixed Frequency Internal Oscillator
- TTL Shutdown Capability, Low Power Standby Mode
- High Efficiency
- Uses Readily Available Standard Inductors
- Thermal Shutdown and Current Limit Protection

Pin connections

1. Vin
2. Output
3. Ground
4. Feedback
5. ON/OFF

Applications

- Simple High-Efficiency Step-Down (Buck) Regulator
- Efficient Pre-Regulator for Linear Regulators
- On-Card Switching Regulators
- Positive to Negative Converter (Buck-Boost)
- Negative Step-Up Converters
- Power Supply for Battery Chargers

Typical Application (Fixed Output Voltage Versions)

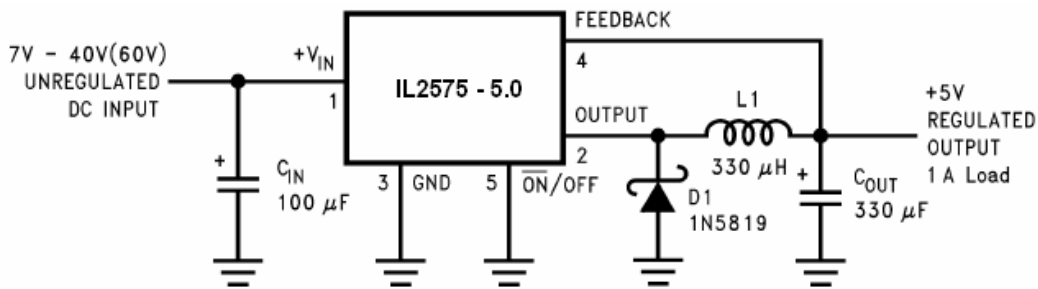

Representative Block Diagram and Typical Application

www.DataSheet4U.com

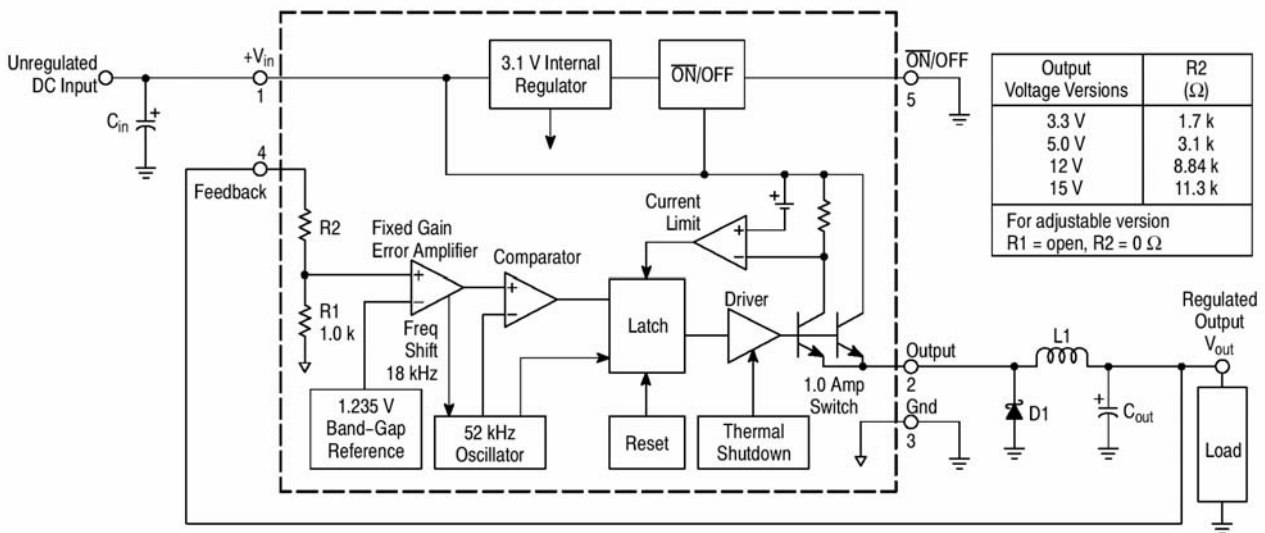

This device contains 162 active transistors.

Figure 1. Block Diagram and Typical Application

ABSOLUTE MAXIMUM RATINGS

(Absolute Maximum Ratings indicate limits beyond which damage to the device may occur.)

Rating	Symbol	Value	Unit
Maximum Supply Voltage	V _{in}	45	V
ON/OFF Pin Input Voltage	—	-0.3 V ≤ V ≤ +V _{in}	V
Output Voltage to Ground (Steady-State)	—	-1.0	V
Power Dissipation TO-220, 5-Lead	P _D	Internally Limited	W
Thermal Resistance, Junction-to-Ambient	R _{θJA}	65	°C/W
Thermal Resistance, Junction-to-Case D2PAK	R _{θJC}	5.0	°C/W
Power Dissipation	P _D	Internally Limited	W
Thermal Resistance, Junction-to-Ambient	R _{θJA}	70	°C/W
Thermal Resistance, Junction-to-Case	R _{θJC}	5.0	°C/W
Storage Temperature Range	T _{stg}	-65 to +150	°C
Minimum ESD Rating (Human Body Model: C = 100 pF, R = 1.5 kΩ)	—	2.0	kV
Lead Temperature (Soldering, 10 seconds)	—	260	°C
Maximum Junction Temperature	T _J	150	°C

OPERATING RATINGS

(Operating Ratings indicate conditions for which the device is intended to be functional, but do not guarantee specific performance limits. For guaranteed specifications and test conditions, see the Electrical Characteristics.)

Rating	Symbol	Value	Unit
Operating Junction Temperature Range	T _J	-40 to +125	°C
Supply Voltage	V _{in}	40	V

SYSTEM PARAMETERS [Note 1]

ELECTRICAL CHARACTERISTICS

(Unless otherwise specified, V_{in} = 12 V for the 3.3 V, 5.0 V, and Adjustable version, V_{in} = 25 V for the 12 V version, and V_{in} = 30 V for the 15 V version. I_{Load} = 500 mA, T_J = 25°C, for min/max values T_J is the operating junction temperature range that applies [Note 2], unless otherwise noted.)

www.DataSheet4U.com

Characteristics	Symbol	Min	Max	Unit
IL2575-3.3 ([Note 1] Test Circuit Figure 14)				
Output Voltage (V _{in} =12V, I _{Load} =0.2A, T _J =25°C)	V _{out}	3.234	3.366	V
Output Voltage (4.75V ≤ V _{in} ≤ 40V, 0.2A ≤ I _{Load} ≤ 1.0A) T _J = 25°C T _J = -40 to +125°C	V _{out}	3.168 3.135	3.432 3.465	V
Efficiency (V _{in} = 12V, I _{Load} = 1.0A)	η	65	-	%
IL2575-5 [Note 1]				
Output Voltage (V _{in} =12V, I _{Load} =0.2A, T _J =25°C)	V _{out}	4.9	5.1	V
Output Voltage (8.0V ≤ V _{in} ≤ 40V, 0.2A ≤ I _{Load} ≤ 1.0A) T _J = 25°C T _J = -40 to +125°C	V _{out}	4.8 4.75	5.2 5.25	V
Efficiency (V _{in} = 12 V, I _{Load} = 1.0 A)	η	67	-	%
IL2575-12 [Note 1]				
Output Voltage (V _{in} =25V, I _{Load} =0.2A, T _J =25°C)	V _{out}	11.76	12.24	V
Output Voltage (15.0V ≤ V _{in} ≤ 40V, 0.2A ≤ I _{Load} ≤ 1.0A) T _J = 25°C T _J = -40 to +125°C	V _{out}	11.52 11.4	12.48 12.6	V
Efficiency (V _{in} = 15V, I _{Load} = 1.0A)	η	78	-	%
IL2575-15 [Note 1]				
Output Voltage (V _{in} =30V, I _{Load} =0.2A, T _J =25°C)	V _{out}	14.7	15.3	V
Output Voltage (18V ≤ V _{in} ≤ 40V, 0.2A ≤ I _{Load} ≤ 1.0A) T _J = 25°C T _J = -40 to +125°C	V _{out}	14.4 14.25	15.6 15.75	V
Efficiency (V _{in} = 12V, I _{Load} = 1.0A)	η	78	-	%
IL2575 ADJUSTABLE VERSION [Note 1]				
Feedback Voltage (V _{in} =12V, I _{Load} = 0.2A, V _{out} = 5.0V, T _J =25°C)	V _{out}	1.217	1.243	V
Feedback Voltage (8.0V ≤ V _{in} ≤ 40V, 0.2A ≤ I _{Load} ≤ 1.0A, V _{out} =5.0V) T _J = 25°C T _J = -40 to +125°C	V _{out}	1.193 1.18	1.267 1.28	V
Efficiency (V _{in} = 12V, I _{Load} = 1.0A, V _{out} = 5.0V)	η	67	-	%

1. External components such as the catch diode, inductor, input and output capacitors can affect switching regulator system performance.

When the IL2575 is used as shown in the test circuit 14, system performance will be as shown in system parameters section .

2. Tested junction temperature range for the IL2575: T_{low} = -40°C T_{high} = +125°C

DEVICE PARAMETERS

ELECTRICAL CHARACTERISTICS

(Unless otherwise specified, $V_{in} = 12\text{ V}$ for the 3.3 V, 5.0 V, and Adjustable version, $V_{in} = 25\text{ V}$ for the 12 V version, and $V_{in} = 30\text{ V}$ for the 15 V version. $I_{Load} = 500\text{ mA}$, $T_J = 25^\circ\text{C}$, for min/max values T_J is the operating junction temperature range that applies [Note 2], unless otherwise noted.)

Characteristics	Symbol	Min	Max	Unit
ALL OUTPUT VOLTAGE VERSIONS				
Feedback Bias Current ($V_{out} = 5.0\text{ V}$ [Adjustable Version Only]) $T_J = 25^\circ\text{C}$ $T_J = -40\text{ to }+125^\circ\text{C}$	I_b	– –	100 500	nA
Oscillator Frequency [Note 3] $T_J = 25^\circ\text{C}$ $T_J = -40\text{ to }+125^\circ\text{C}$	f_{osc}	– 42	– 63	kHz
Saturation Voltage ($I_{out} = 1.0\text{ A}$ [Note 4]) $T_J = 25^\circ\text{C}$ $T_J = -40\text{ to }+125^\circ\text{C}$	V_{sat}	– –	1.8 2.0	V
Max Duty Cycle ("on") [Note 5]	D_C	93	–	%
Current Limit (Peak Current [Notes 3 and 4]) $T_J = 25^\circ\text{C}$ $T_J = -40\text{ to }+125^\circ\text{C}$	I_{CL}	4.2 3.5	6.9 7.5	A
Output Leakage Current [Notes 6 and 7], $T_J = 25^\circ\text{C}$ Output = 0 V Output = –1.0 V	I_L	– –	2.0 30	mA
Quiescent Current [Note 6] $T_J = 25^\circ\text{C}$ $T_J = -40\text{ to }+125^\circ\text{C}$	I_Q	– –	10 11	mA
Standby Quiescent Current (ON/OFF Pin = 5.0 V ("off")) $T_J = 25^\circ\text{C}$	I_{stby}	–	200	uA
ON/OFF Pin Logic Input Level $V_{out} = 0\text{ V}$ $T_J = 25^\circ\text{C}$ $T_J = -40\text{ to }+125^\circ\text{C}$ $V_{out} = \text{Nominal Output Voltage}$ $T_J = 25^\circ\text{C}$ $T_J = -40\text{ to }+125^\circ\text{C}$	V_{IH} V_{IL}	2.2 2.4 – –	– – 1.0 0.8	V
ON/OFF Pin Input Current ON/OFF Pin = 5.0 V ("off"), $T_J = 25^\circ\text{C}$ ON/OFF Pin = 0 V ("on"), $T_J = 25^\circ\text{C}$	I_{IH} I_{IL}	– –	30 10	uA

3. The oscillator frequency reduces to approximately 18 kHz in the event of an output short or an overload which causes the regulated output voltage to drop approximately 40% from the nominal output voltage. This self protection feature lowers the average dissipation of the IC by lowering the minimum duty cycle from 5% down to approximately 2%.

4. Output (Pin 2) sourcing current. No diode, inductor or capacitor connected to output pin.

5. Feedback (Pin 4) removed from output and connected to 0 V.

6. Feedback (Pin 4) removed from output and connected to +12 V for the Adjustable, 3.3 V, and 5.0 V versions, and +25 V for the 12 V and 15 V versions, to force the output transistor "off".

7. $V_{in} = 40\text{ V}$.

TYPICAL PERFORMANCE CHARACTERISTICS (Circuit of Figure 14)

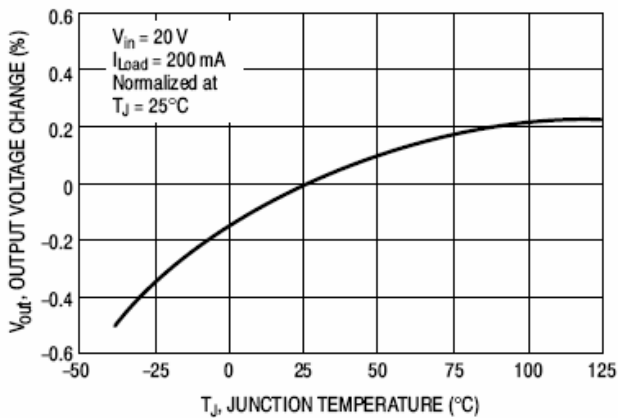

www.DataSheet4U.com Figure 2. Normalized Output Voltage

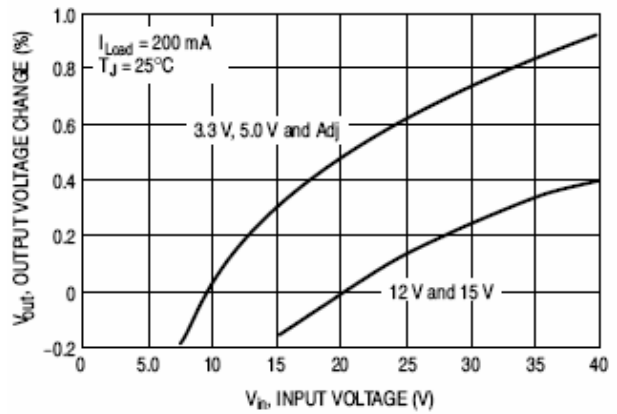

Figure 3. Line Regulation

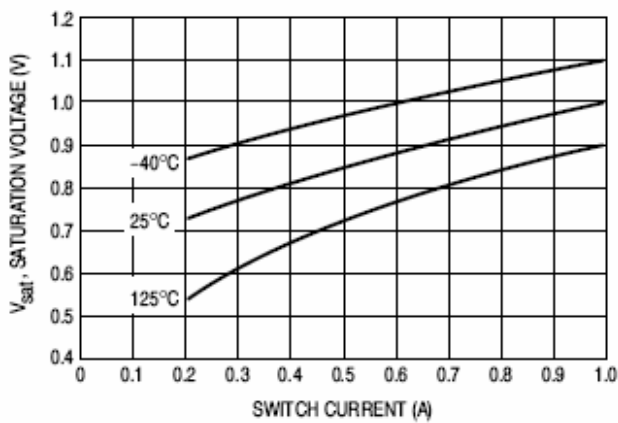

Figure 4. Switch Saturation Voltage

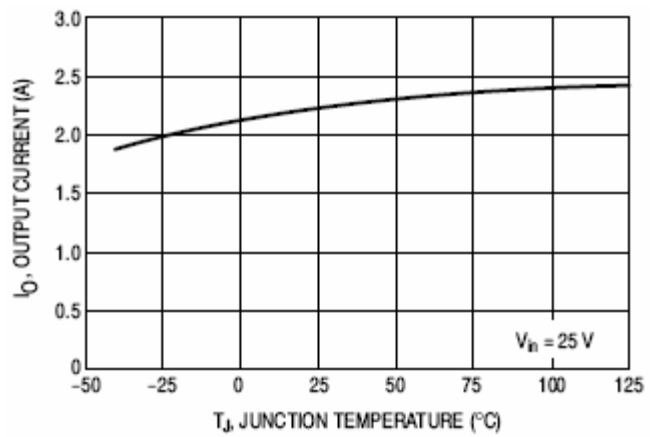

Figure 5. Current Limit

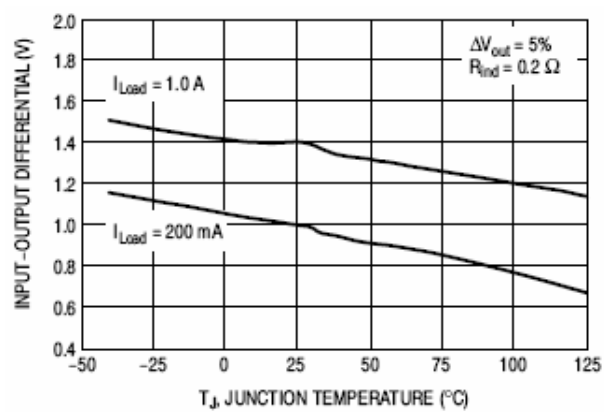

Figure 6. Dropout Voltage

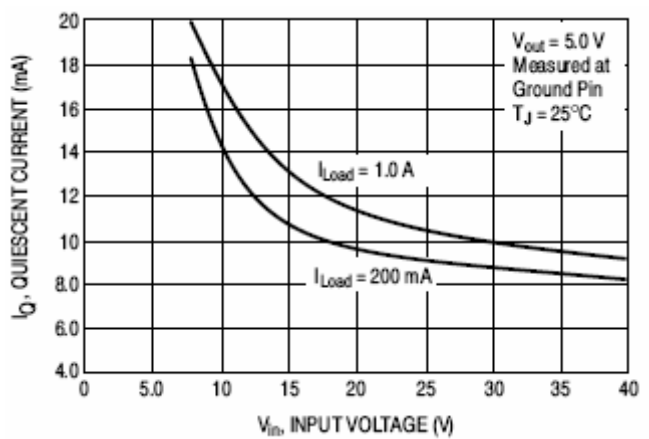

Figure 7. Quiescent Current

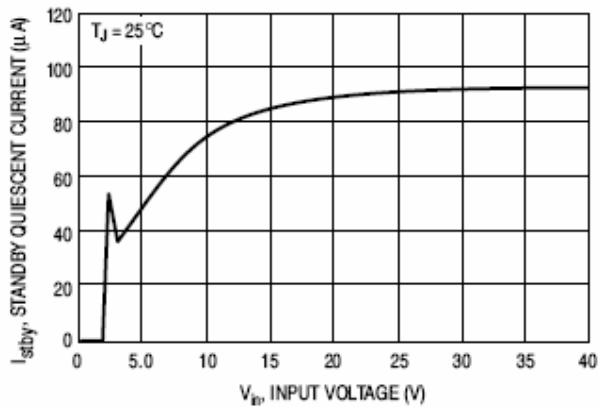

Figure 8. Standby Quiescent Current

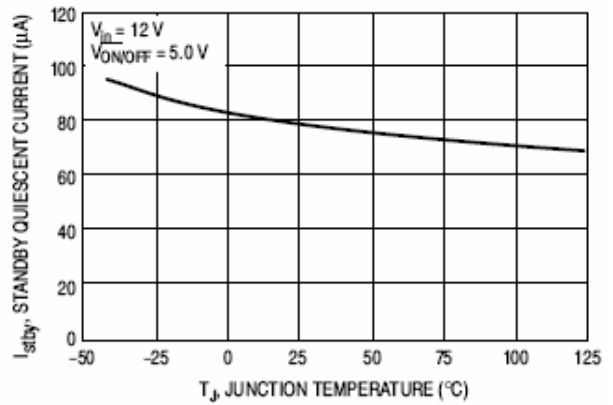

Figure 9. Standby Quiescent Current

www.DataSheet4U.com

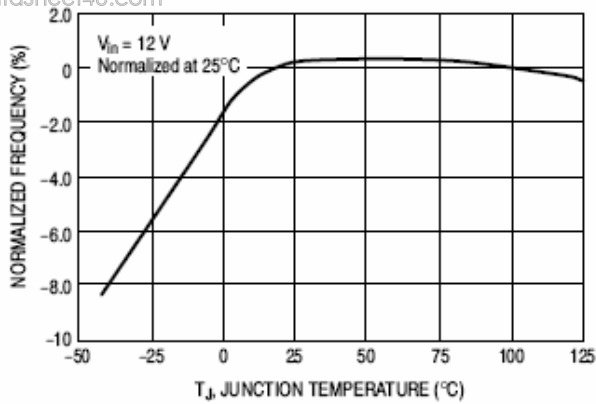

Figure 10. Oscillator Frequency

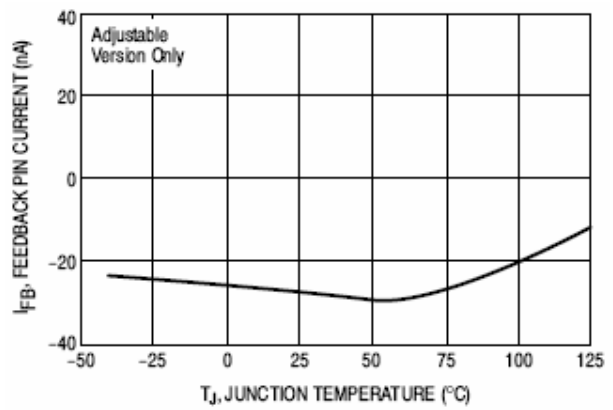

Figure 11. Feedback Pin Current

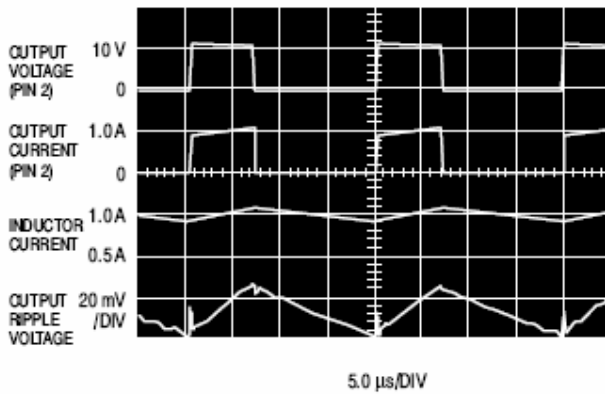

Figure 12. Switching Waveforms

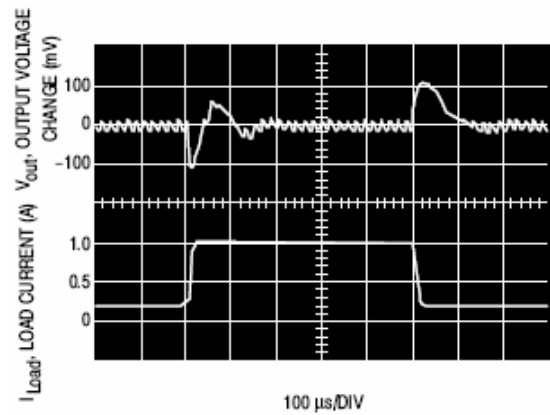
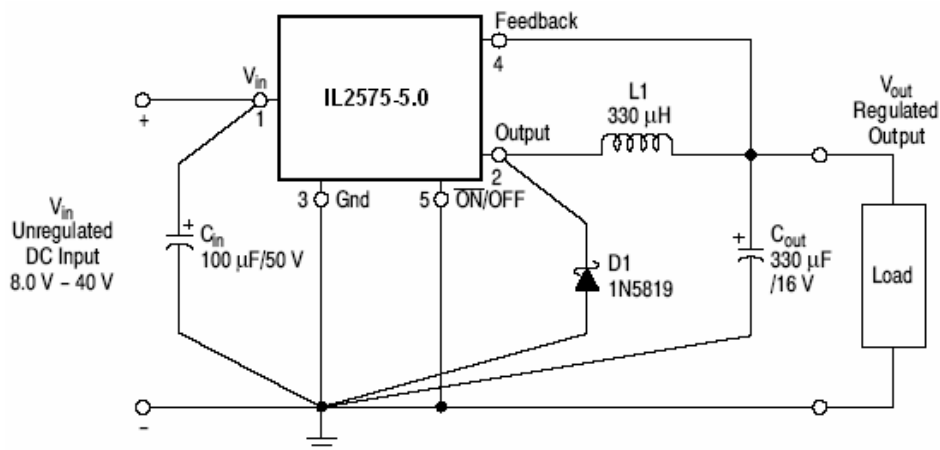
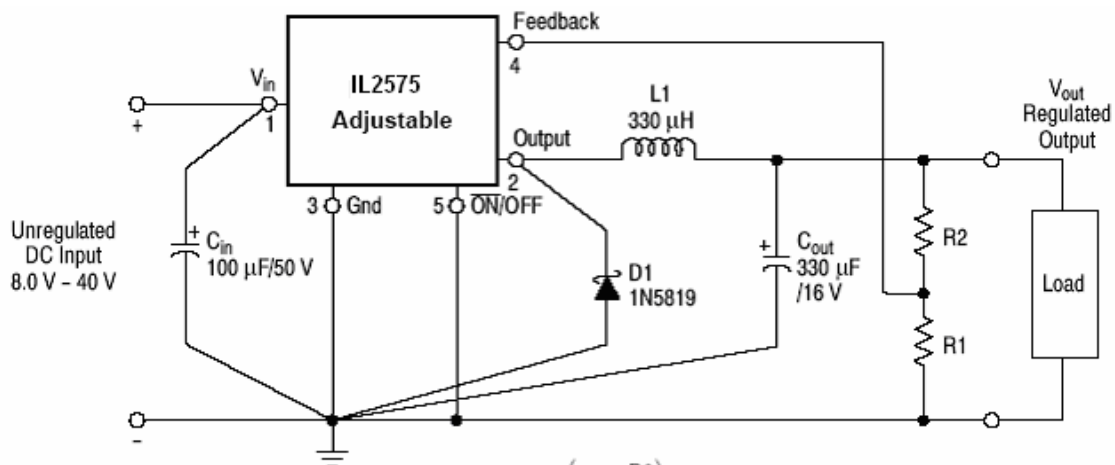

Figure 13. Load Transient Response



5.0 Output Voltage Versions



$$V_{out} = V_{ref} \left(1 + \frac{R2}{R1} \right)$$

$$R2 = R1 \left(\frac{V_{out}}{V_{ref}} - 1 \right)$$

Where $V_{ref} = 1.23 \text{ V}$, $R1$ between $1.0 \text{ k}\Omega$ and $5.0 \text{ k}\Omega$

Adjustable Output Voltage Versions

Figure 14. Typical Test Circuits

PCB LAYOUT GUIDELINES

As in any switching regulator, the layout of the printed circuit board is very important. Rapidly switching currents associated with wiring inductance, stray capacitance and parasitic inductance of the printed circuit board traces can generate voltage transients which can generate electromagnetic interferences (EMI) and affect the desired operation. As indicated in the Figure 14, to minimize inductance and ground loops, the length of the leads indicated by heavy lines should be kept as short as possible. For best results, single-point grounding (as indicated) or ground plane construction should be used.

On the other hand, the PCB area connected to the Pin 2 (emitter of the internal switch) of the IL2575 should be kept to a minimum in order to minimize coupling to sensitive circuitry. Another sensitive part of the circuit is the feedback. It is important to keep the sensitive feedback wiring short. To assure this, physically locate the programming resistors near to the regulator, when using the adjustable version of the IL2575 regulator.

APPLICATION INFORMATION

INVERTING REGULATOR

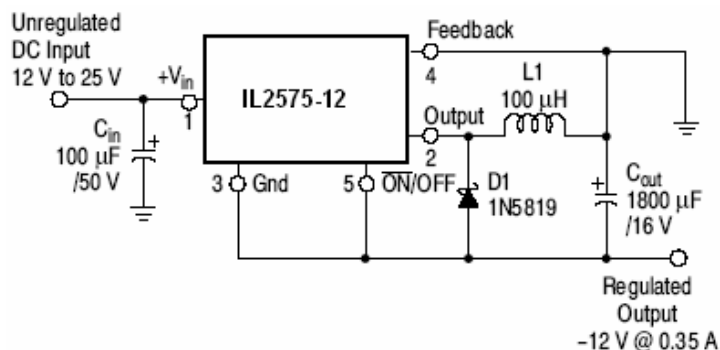

Figure 15. Inverting Buck–Boost Regulator Using the IL2575–12 Develops –12 V @ 0.35 A

An inverting buck–boost regulator using the IL2575–12 is shown in Figure 15. This circuit converts a positive input voltage to a negative output voltage with a common ground by bootstrapping the regulators ground to the negative output voltage. By grounding the feedback pin, the regulator senses the inverted output voltage and regulates it.

In this example the IL2575–12 is used to generate a –12 V output. The maximum input voltage in this case cannot exceed +28 V because the maximum voltage appearing across the regulator is the absolute sum of the input and output voltages and this must be limited to a maximum of 40 V.

This circuit configuration is able to deliver approximately 0.35 A to the output when the input voltage is 12 V or higher. At lighter loads the minimum input voltage required drops to approximately 4.7 V, because the buck–boost regulator topology can produce an output voltage that, in its absolute value, is either greater or less than the input voltage.

Since the switch currents in this buck–boost configuration are higher than in the standard buck converter topology, the available output current is lower.

This type of buck–boost inverting regulator can also require a larger amount of startup input current, even for light loads. This may overload an input power source with a current limit less than 1.5 A.

Such an amount of input startup current is needed for at least 2.0 ms or more. The actual time depends on the output voltage and size of the output capacitor.

Because of the relatively high startup currents required by this inverting regulator topology, the use of a delayed startup or an undervoltage lockout circuit is recommended.

Using a delayed startup arrangement, the input capacitor can charge up to a higher voltage before the switch–mode regulator begins to operate.

The high input current needed for startup is now partially supplied by the input capacitor C_{in} .

Design Recommendations:

The inverting regulator operates in a different manner than the buck converter and so a different design procedure has to be used to select the inductor L_1 or the output capacitor C_{out} .

The output capacitor values must be larger than is normally required for buck converter designs. Low input voltages or high output currents require a large value output capacitor (in the range of thousands of μF).

The recommended range of inductor values for the inverting converter design is between 68 μH and 220 μH . To select an inductor with an appropriate current rating, the inductor peak current has to be calculated.

The following formula is used to obtain the peak inductor current:

$$I_{\text{peak}} \approx \frac{I_{\text{Load}} (V_{\text{in}} + |V_{\text{O}}|)}{V_{\text{in}}} + \frac{V_{\text{in}} \times t_{\text{on}}}{2L_1}$$

$$\text{where } t_{\text{on}} = \frac{|V_{\text{O}}|}{V_{\text{in}} + |V_{\text{O}}|} \times \frac{1}{f_{\text{osc}}}, \text{ and } f_{\text{osc}} = 52 \text{ kHz.}$$

Under normal continuous inductor current operating conditions, the worst case occurs when V_{in} is minimal. Note that the voltage appearing across the regulator is the absolute sum of the input and output voltage, and must not exceed 40 V.

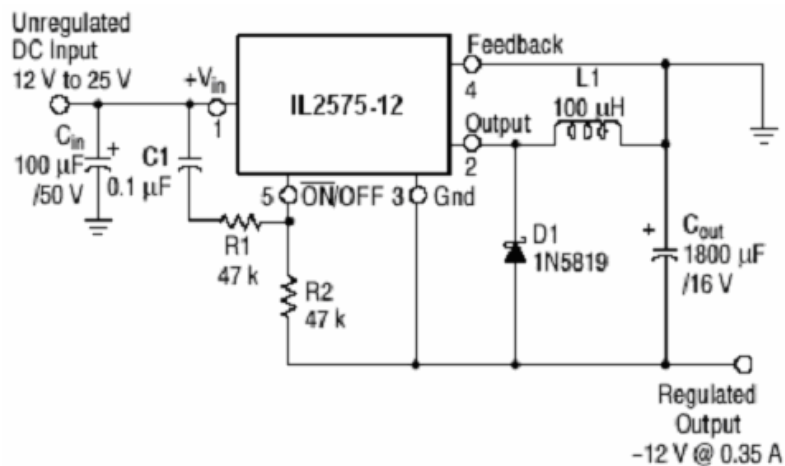

www.DataSheet4U.com

Figure 16. Inverting Buck-Boost Regulator with Delayed Startup

It has been already mentioned above, that in some situations, the delayed startup or the undervoltage lockout features could be very useful. A delayed startup circuit applied to a buck-boost converter is shown in Figure 16. Figure 22 in the “Undervoltage Lockout” section describes an undervoltage lockout feature for the same converter topology.

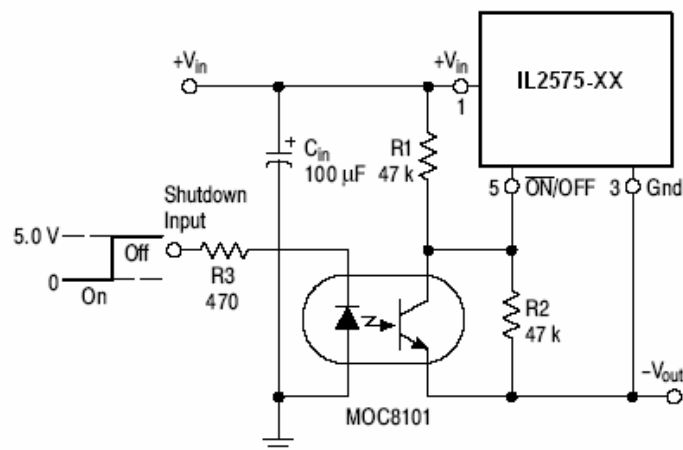

NOTE: This picture does not show the complete circuit.

Figure 17. Inverting Buck-Boost Regulator Shut Down Circuit Using an Optocoupler

With the inverting configuration, the use of the ON/OFF pin requires some level shifting techniques. This is caused by the fact, that the ground pin of the converter IC is no longer at ground. Now, the ON/OFF pin threshold voltage (1.4 V approximately) has to be related to the negative output voltage level. There are many different possible shut down methods, two of them are shown in Figures 17 and 18.

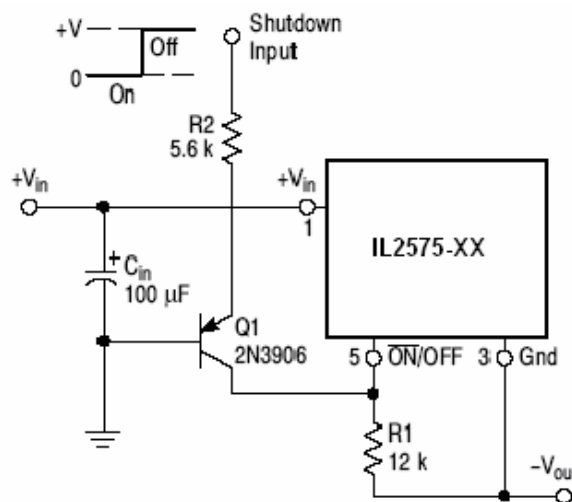

www.DataSheet4U.com

NOTE: This picture does not show the complete circuit.

Figure 18. Inverting Buck-Boost Regulator Shut Down Circuit Using a PNP Transistor

Negative Boost Regulator

This example is a variation of the buck-boost topology and is called a negative boost regulator. This regulator experiences relatively high switch current, especially at low input voltages. The internal switch current limiting results in lower output load current capability.

The circuit in Figure 19 shows the negative boost configuration. The input voltage in this application ranges from -5.0 V to -12 V and provides a regulated -12 V output.

If the input voltage is greater than -12 V, the output will rise above -12 V accordingly, but will not damage the regulator.

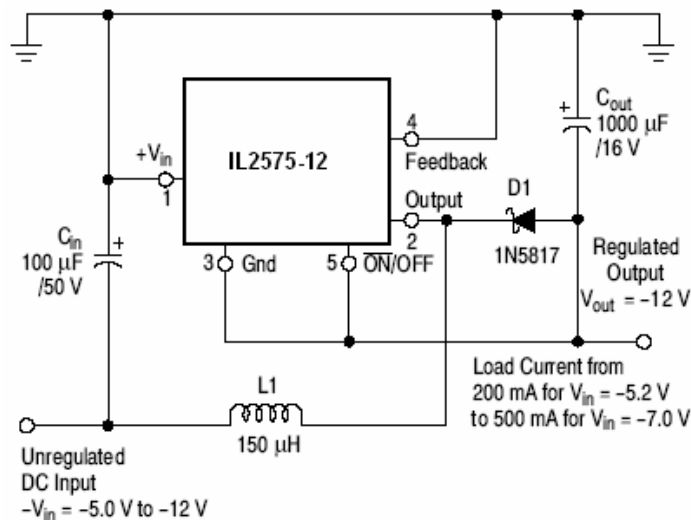

Figure 19. Negative Boost Regulator

Design Recommendations:

The same design rules as for the previous inverting buck-boost converter can be applied. The output capacitor C_{out} must be chosen larger than would be required for a standard buck converter. Low input voltages or high output currents require a large value output capacitor (in the range of thousands of μF). The recommended range of inductor values for the negative boost regulator is the same as for inverting converter design.

Another important point is that these negative boost converters cannot provide current limiting load protection in the event of a short in the output so some other means, such as a fuse, may be necessary to provide the load protection.

Delayed Startup

There are some applications, like the inverting regulator already mentioned above, which require a higher amount of startup current. In such cases, if the input power source is limited, this delayed startup feature becomes very useful. To provide a time delay between the time the input voltage is applied and the time when the output voltage comes up, the circuit in Figure 20 can be used. As the input voltage is applied, the capacitor C1 charges up, and the voltage across the resistor R2 falls down. When the voltage on the ON/OFF pin falls below the threshold value 1.4 V, the regulator starts up. Resistor R1 is included to limit the maximum voltage applied to the ON/OFF pin, reduces the power supply noise sensitivity, and also limits the capacitor C1 discharge current, but its use is not mandatory.

When a high 50 Hz or 60 Hz (100 Hz or 120 Hz respectively) ripple voltage exists, a long delay time can cause some problems by coupling the ripple into the ON/OFF pin, the regulator could be switched periodically on and off with the line (or double) frequency.

www.DataSheet4U.com

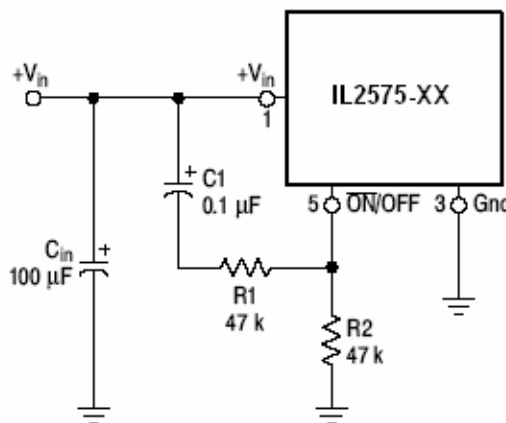

NOTE: This picture does not show the complete circuit.
Figure 20. Delayed Startup Circuitry

Undervoltage Lockout

Some applications require the regulator to remain off until the input voltage reaches a certain threshold level. Figure 21 shows an undervoltage lockout circuit applied to a buck regulator. A version of this circuit for buck–boost converter is shown in Figure 22. Resistor R3 pulls the ON/OFF pin high and keeps the regulator off until the input voltage reaches a predetermined threshold level, which is determined by the following expression:

$$V_{th} \approx V_{Z1} + \left(1 + \frac{R2}{R1}\right) V_{BE} (Q1)$$

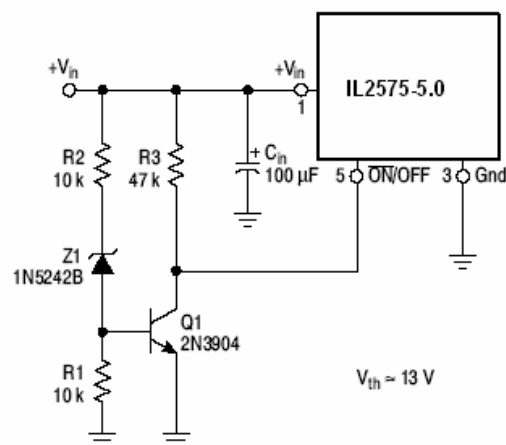

NOTE: This picture does not show the complete circuit.
Figure 21. Undervoltage Lockout Circuit for Buck Converter

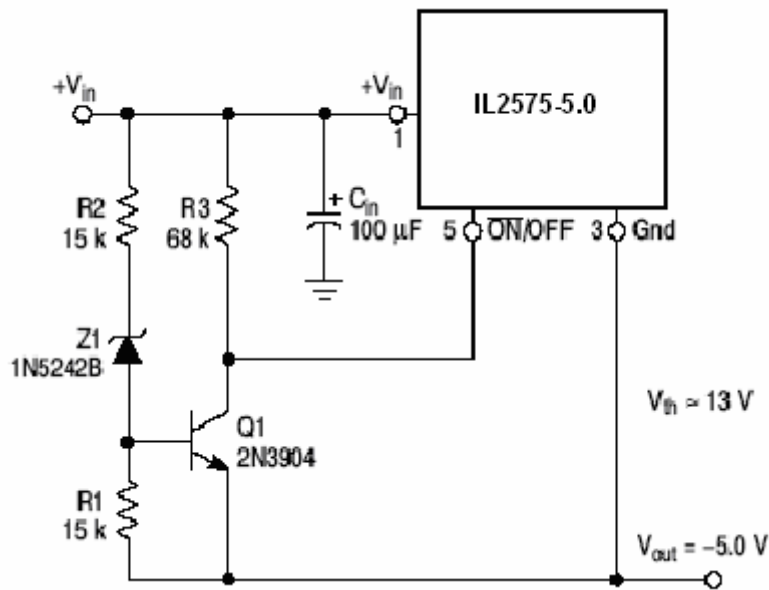

NOTE: This picture does not show the complete circuit.
Figure 22. Undervoltage Lockout Circuit for Buck-Boost Converter

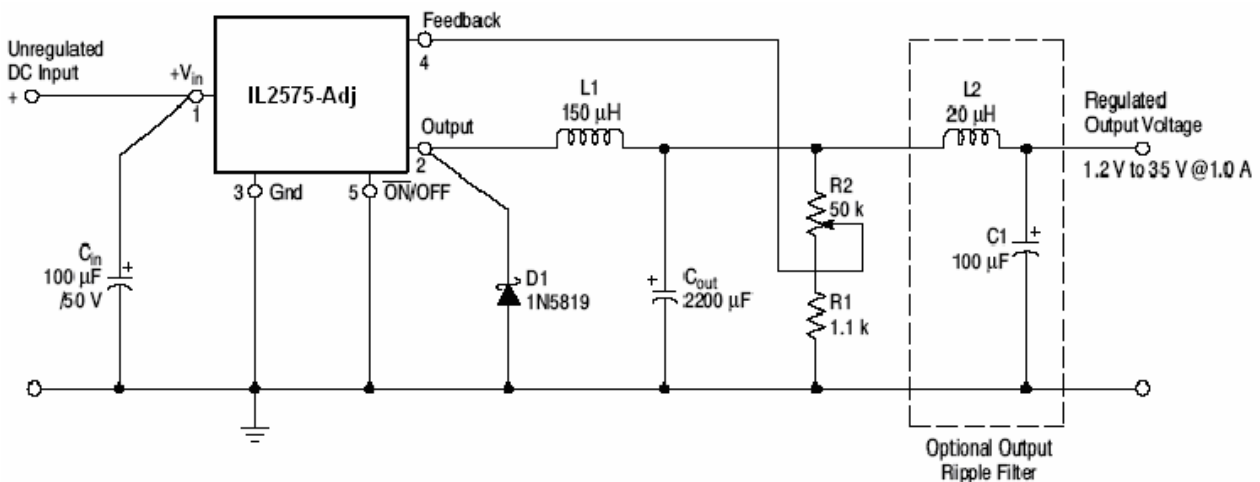

Figure 23. Adjustable Power Supply with Low Ripple Voltage

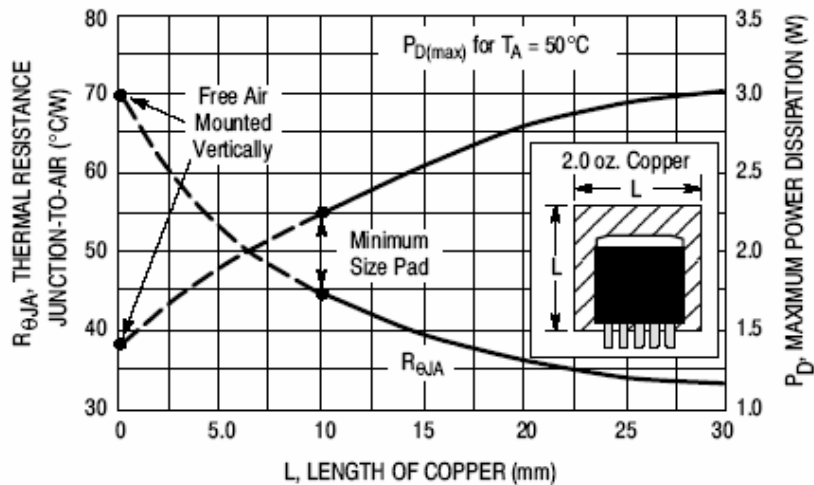

Figure 24. D2PAK Thermal Resistance and Maximum Power Dissipation versus P.C.B. Copper Length

THE IL2575-5.0 STEP-DOWN VOLTAGE REGULATOR WITH 5.0 V @ 1.0 A OUTPUT POWER CAPABILITY. TYPICAL APPLICATION WITH THROUGH-HOLE PC BOARD LAYOUT

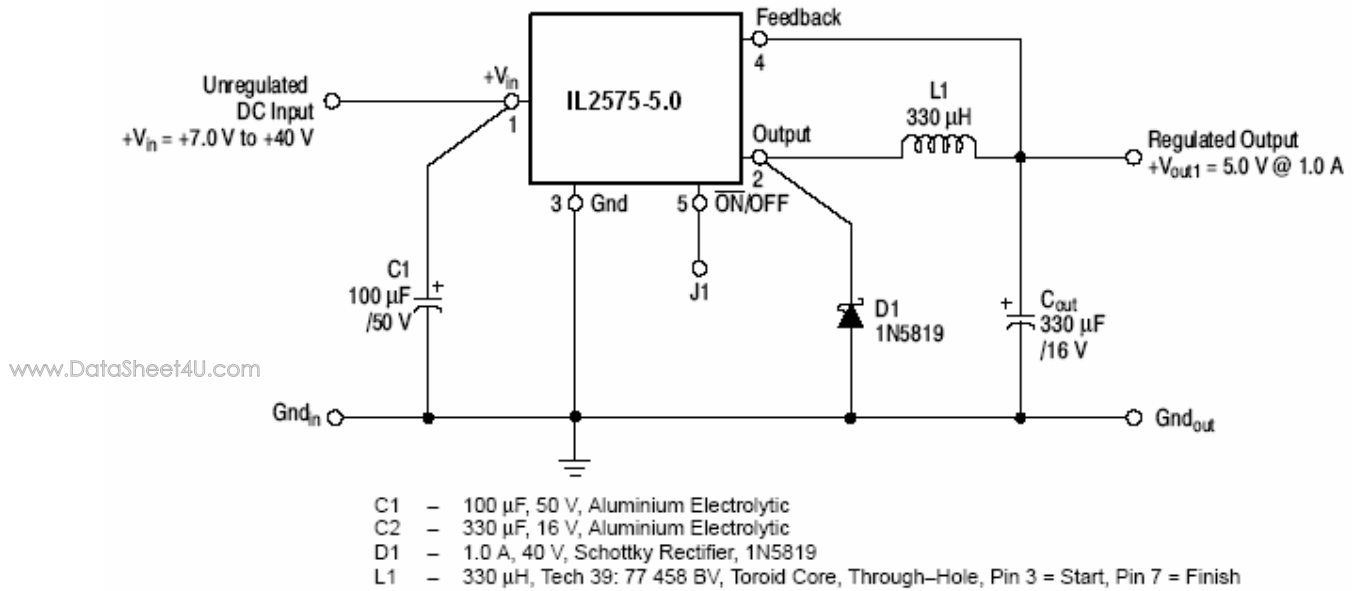

Figure 25. Schematic Diagram of the IL2575-5.0 Step-Down Converter

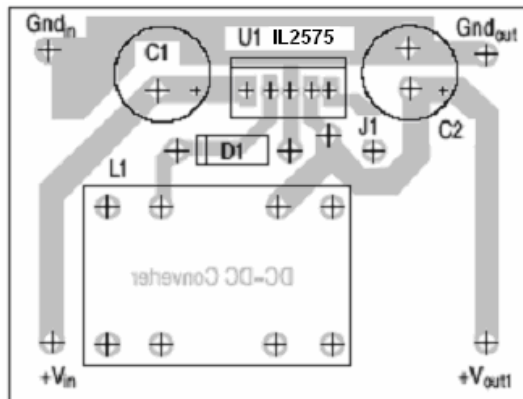

Figure 26. Printed Circuit Board Component Side

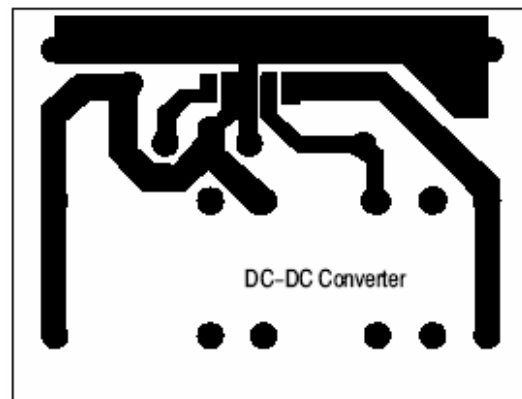

Figure 27. Printed Circuit Board Copper Side

THE IL2575-ADJ STEP-DOWN VOLTAGE REGULATOR WITH 8.0 V @ 1.0 A OUTPUT POWER CAPABILITY. TYPICAL APPLICATION WITH THROUGH-HOLE PC BOARD LAYOUT

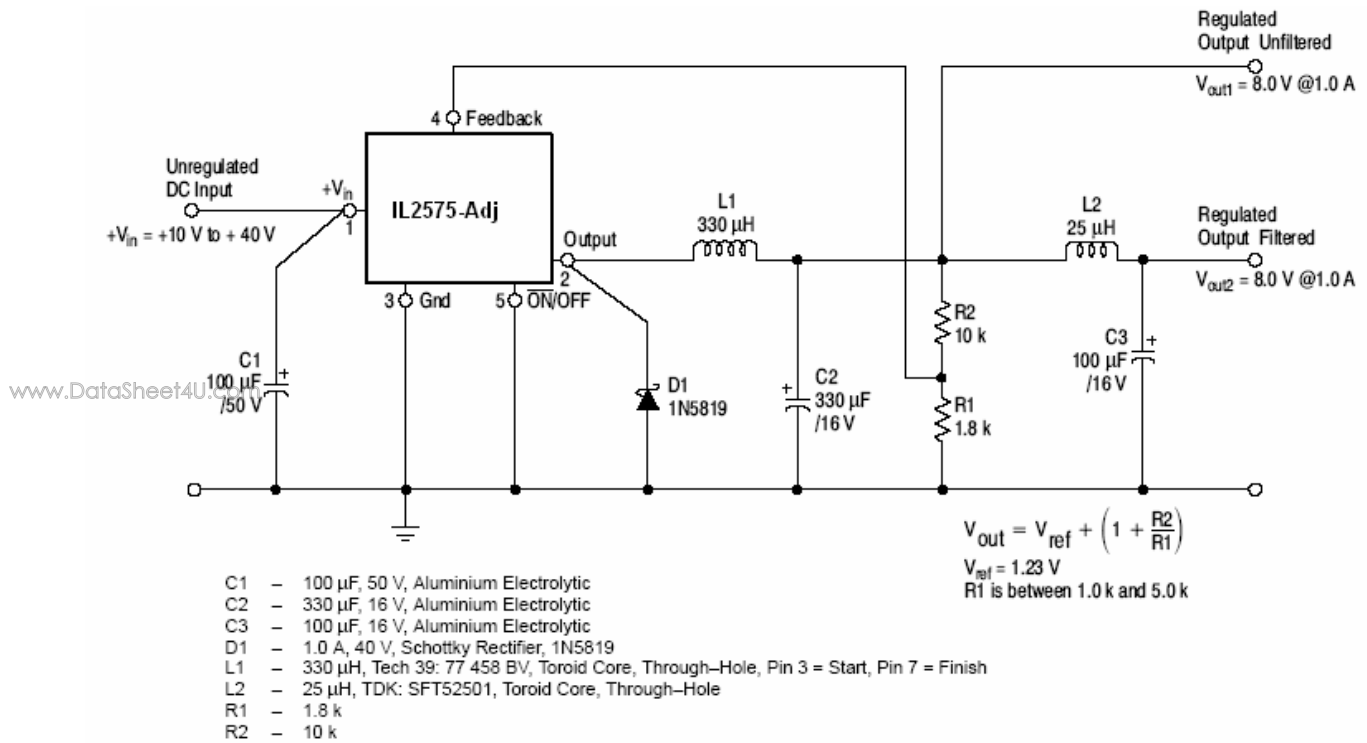
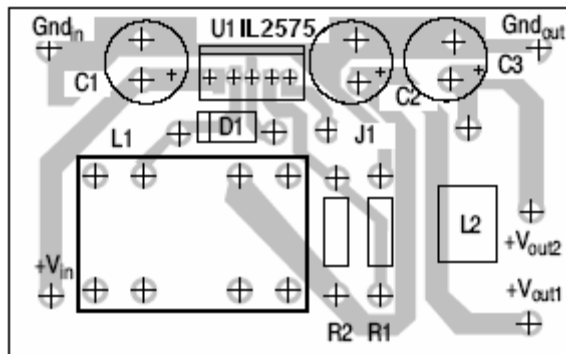
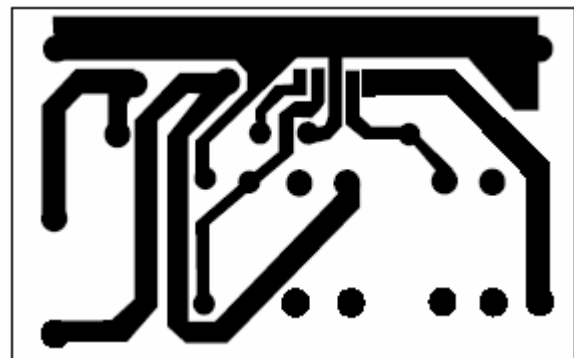

Figure 28. Schematic Diagram of the 8.0 V @ 1.0 V Step-Down Converter Using the IL2575-Adj
 (An additional LC filter is included to achieve low output ripple voltage)



NOTE: Not to scale.

Figure 29. PC Board Component Side



NOTE: Not to scale.

Figure 30. PC Board Copper Side

TO-220-5L

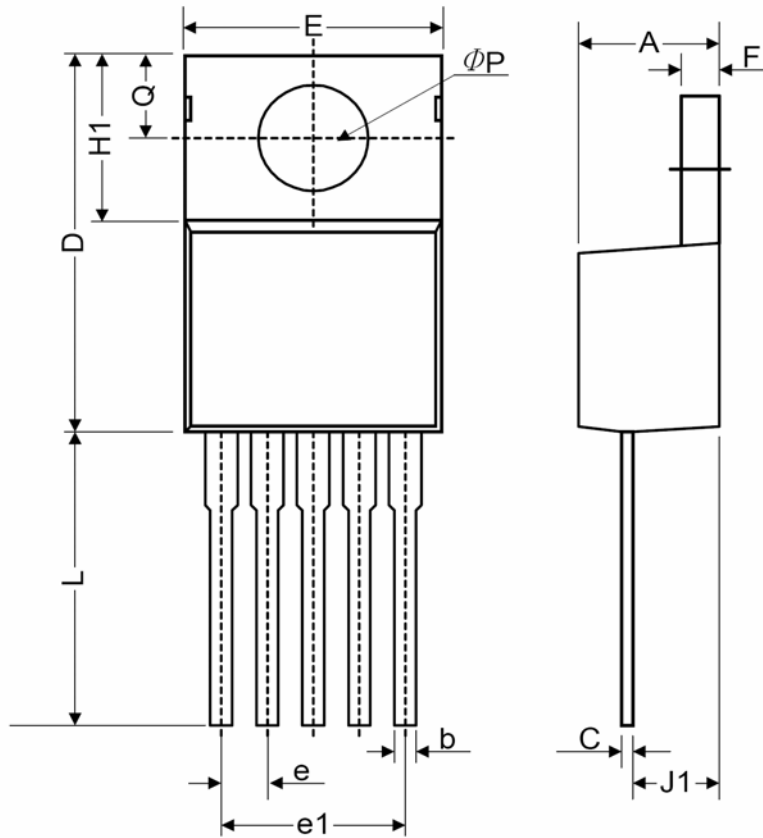

www.DataSheet4U.com

Symbol	Dimensions In Millimeters			Dimensions In Inches		
	Min.	Nom.	Max.	Min.	Nom.	Max.
A	4.07	4.45	4.82	0.160	0.175	0.190
b	0.76	0.89	1.02	0.030	0.035	0.040
C	0.36	0.50	0.64	0.014	0.020	0.025
D	14.22	14.86	15.50	0.560	0.585	0.610
E	9.78	10.16	10.54	0.385	0.400	0.415
e	1.57	1.71	1.85	0.062	0.067	0.073
e1	6.68	6.81	6.93	0.263	0.268	0.273
F	1.14	1.27	1.40	0.045	0.050	0.055
H1	5.46	6.16	6.86	0.215	0.243	0.270
J1	2.29	2.74	3.18	0.090	0.108	0.125
L	13.21	13.97	14.73	0.520	0.550	0.580
Øp	3.68	3.81	3.94	0.145	0.150	0.155
Q	2.54	2.73	2.92	0.100	0.107	0.115

TO-220-5L (Bent Staggered)

www.DataSheet4U.com

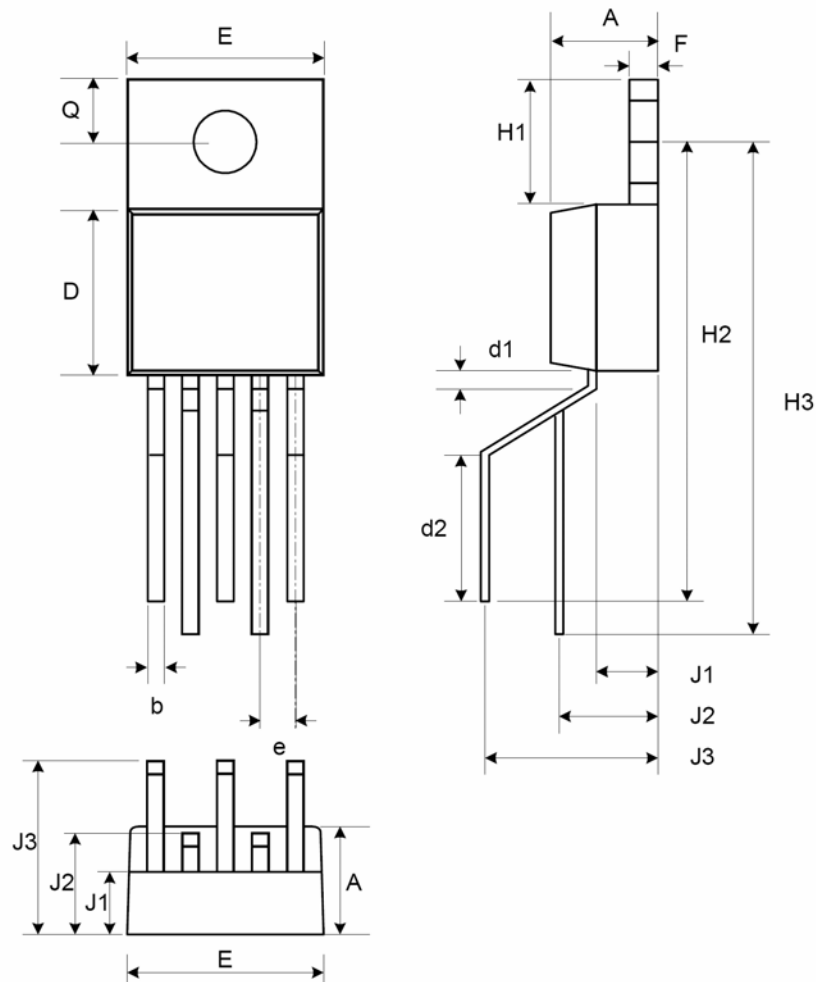

Symbol	Dimensions In Millimeters			Dimensions In Inches		
	Min.	Nom.	Max.	Min.	Nom.	Max.
A	4.4	4.6	4.7	0.175	0.180	0.185
b	0.7	0.8	0.9	0.027	0.032	0.037
D	8.4	8.7	8.9	0.330	0.340	0.350
d1	1.0			0.039		
d2	6.3			0.248		
E	9.91	10.16	10.41	0.390	0.400	0.410
e	1.6	1.7	1.8	0.062	0.067	0.072
F	1.2	1.25	1.3	0.048	0.050	0.052
H1	6.4			0.250		
H2	20.8	21.6	22.4	0.820	0.850	0.880
H3	23.9	24.7	25.5	0.942	0.972	1.002
J1	2.7			0.105		
J2	3.7	4.5	5.3	0.147	0.177	0.207
J3	8.4			0.331		
Q	2.5	2.8	3.0	0.100	0.110	0.120

TO-263-5L

www.DataSheet4U.com

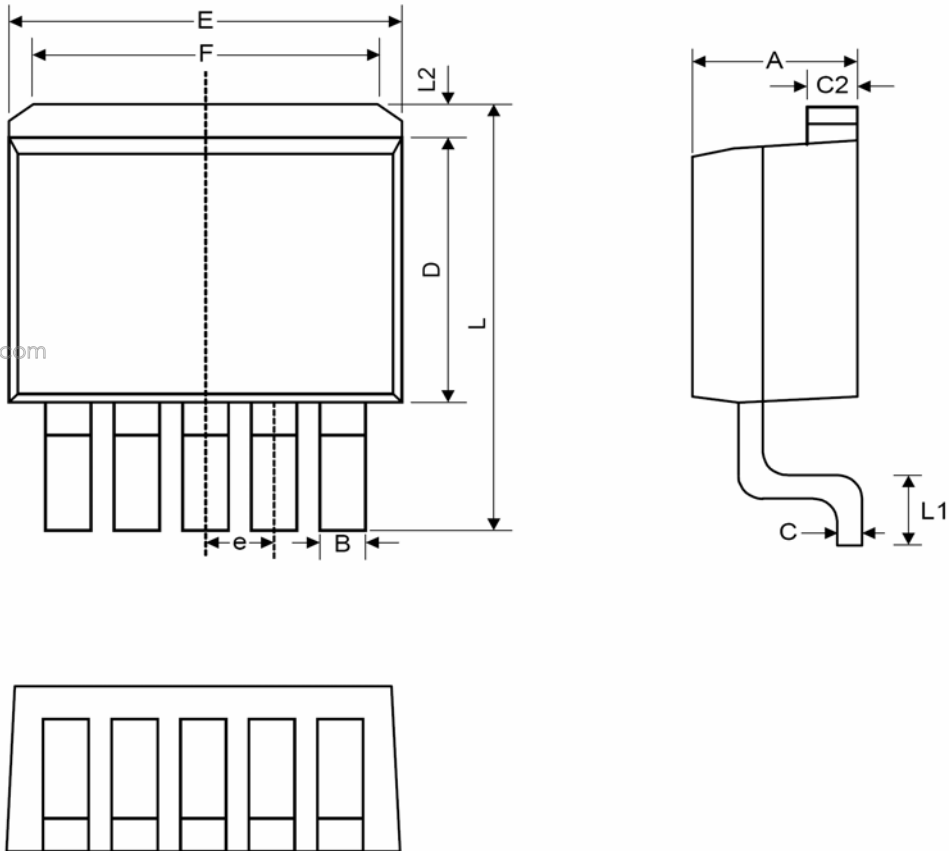

Symbol	Dimensions In Millimeters			Dimensions In Inches		
	Min.	Nom.	Max.	Min.	Nom.	Max.
A	4.07	4.46	4.85	0.160	0.176	0.191
B	0.66	0.84	1.02	0.026	0.033	0.040
C	0.36	0.50	0.64	0.014	0.020	0.025
C2	1.14	1.27	1.40	0.045	0.050	0.055
D	8.65	9.15	9.65	0.341	0.360	0.380
E	9.78	10.16	10.54	0.385	0.400	0.415
e	1.57	1.71	1.85	0.062	0.068	0.073
F	6.60	6.86	7.11	0.260	0.270	0.280
L	14.61	15.24	15.88	0.575	0.600	0.625
L1	2.29	2.54	2.79	0.090	0.100	0.110
L2	-	-	2.92	-	-	0.115