

LED Driver with Average-Mode Constant Current Control (functional analog HV9961 Supertex Inc.)

The IL3361 is an average current, mode control LED driver IC operating in a constant off-time mode. This control IC does not produce a peak-to-average error, and therefore greatly improves accuracy, line and load regulation of the LED current without any need for loop compensation or high-side current sensing. The output LED current accuracy is $\pm 3\%$. The IL3361 can be powered from an 8.0 - 450 VDC supply. The output current can be programmed by an internal 272 mV reference, or controlled externally through a 0 - 1.5 V dimming input.

FEATURES:

- Fast average current control
- Programmable constant off-time switching
- Linear dimming input
- PWM dimming input
- Output short circuit protection
- Ambient operating temperature -40°C to $+125^{\circ}\text{C}$
- Pin-compatible with the IL9910 IC

APPLICATIONS:

- DC/DC or AC/DC LED driver applications
- LED backlight driver for LCD displays
- General purpose constant current source
- LED signage and displays
- Architectural and decorative LED lighting
- LED street lighting

Block diagram:

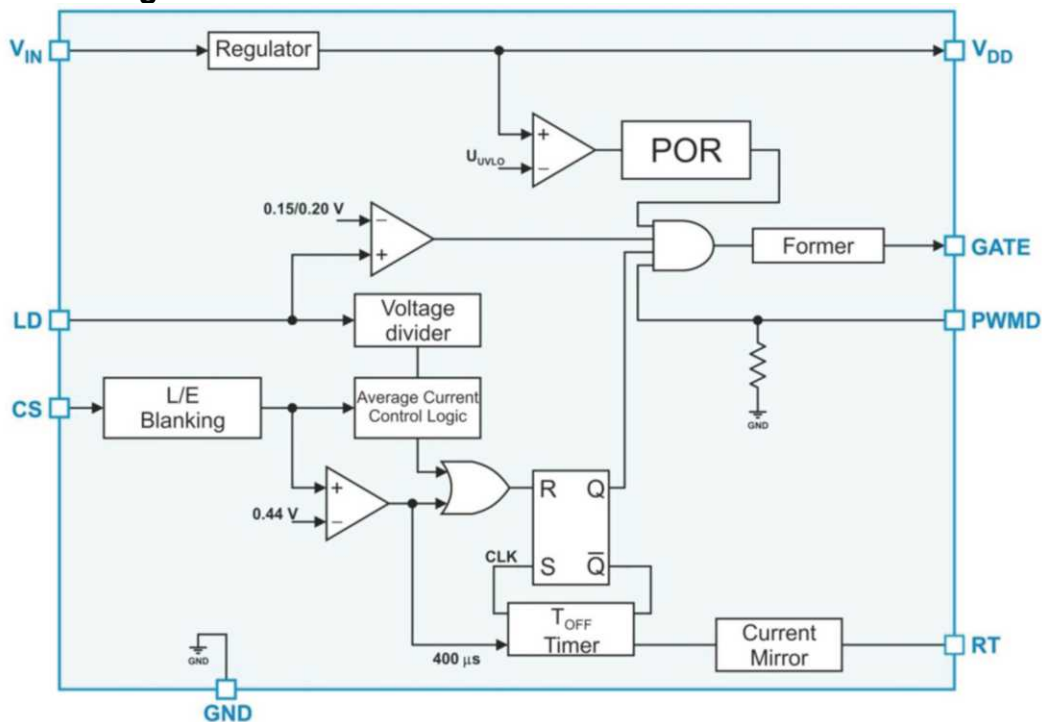

General view of ICs:

IL3361D (plastic SO-8 case)

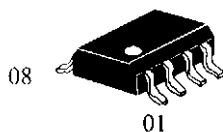

IL3361DH (plastic SO-16 case)

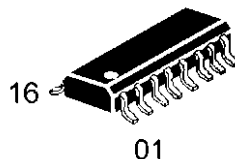

IZ3361 (dice)

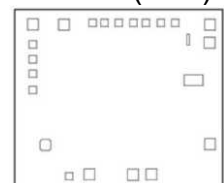

Typical application circuit:

$V_{IN}=8-450\text{ VDC}$

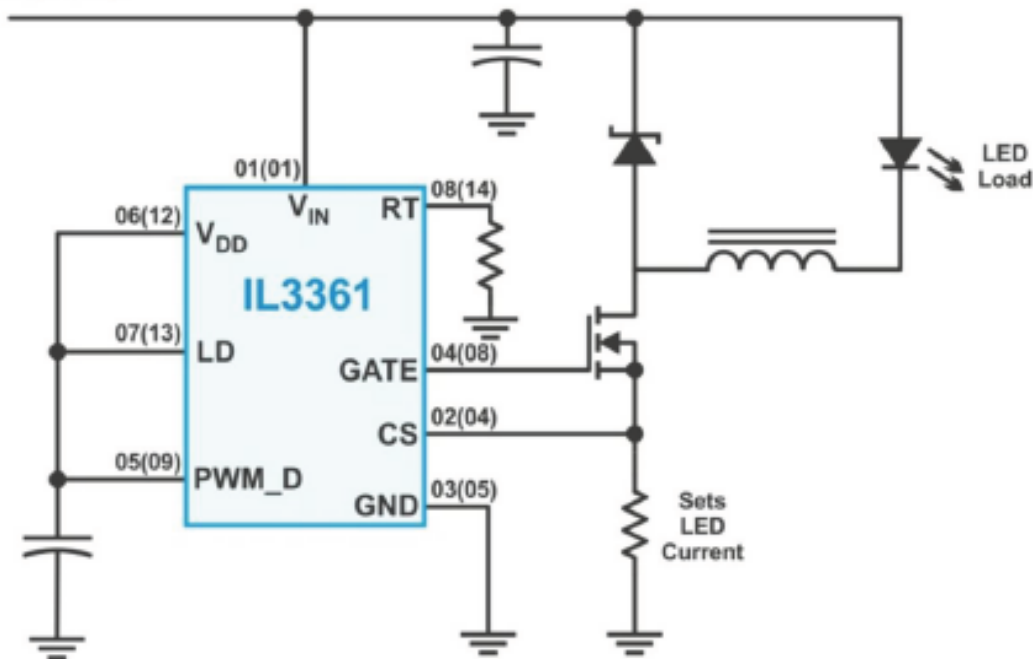

IL3361D pin numbers displayed without brackets, brackets contain pin numbers for IL3361DH.

Pin and Pad Description:

Pad number	Pin number		Symbol	Description
	8-Lead SOIC	16-Lead SOIC ^{1*}		
1	1	1	V_{IN}	Input of an 8.0 - 450V linear regulator
2	-	-	TEST	Test pad ^{2*}
3	2	4	CS	Current sense pin used to sense the FET current by means of an external sense resistor
4, 5 ^{3*}	3	5	GND	Ground return for all internal circuitry
6	4	8	GATE	GATE driver output for an external N-channel power MOSFET
7, 9 ^{4*}	6	12	Vdd	Power supply pin for all internal circuits
8	5	9	PWM D	PWM dimming input of the IC
10	-	-	P6	Test pad ^{2*}
11	-	-	P0	Test pad ^{2*}
12	-	-	P1	Test pad ^{2*}
13	-	-	P2	Test pad ^{2*}
14	-	-	P3	Test pad ^{2*}
15	-	-	P4	Test pad ^{2*}
16	-	-	P5	Test pad ^{2*}
17	7	13	LD	Linear dimming input and it sets the current sense threshold as long as the voltage at this pin is less than 1.5V. If voltage at LD falls below 150mV, the GATE output is disabled. The GATE signal recovers at 200mV at LD
18	8	14	RT	A resistor connected between this pin and GND programs the GATE off-time
19	-	-	Prm2	Test pad ^{2*}
20	-	-	Prm0	Test pad ^{2*}
21	-	-	Prm1	Test pad ^{2*}

Pad number	Pin number		Symbol	Description
	8-Lead SOIC	16-Lead SOIC ^{1*}		
22	-	-	REF	Test pad ^{2*}

Note:

- 1) Pins 2, 3, 6, 7, 10, 11, 15, 16 of IL3361DH are not used
- 2) Contact pad 2, 10-16, 19-22 (test pads) are used for testing process on manufacturing fab only (have not to be bonded by customer)
- 3) Contact pad 4, 5 (Ground) are electrically connected
- 4) Contact pad 7, 9 (Power supply) are electrically connected

Electrical Characteristics:

Symbol	Description	Min	Typ	Max	Units	Conditions
Input						
V _{INDC}	Input DC supply voltage range ^{1*}	8.0	-	450	V	DC input voltage
I _{INSD}	Shut-down mode supply current *	-	-	1.0	mA	Pin PWM_D to GND
Internal Regulator						
V _{DD}	Internally regulated voltage	7.05	-	7.75	V	V _{IN} = 8.0V, I _{DD(ext)} = 0, 500pF at GATE; R _T = 226kΩ, PWM_D = V _{DD}
ΔV _{DD, line}	Line regulation of V _{DD}	0	-	1.0	V	V _{IN} = 8.0 - 450 V, I _{DD(ext)} = 0, 500pF at GATE; R _T = 226kΩ, PWM_D = V _{DD}
ΔV _{DD, load}	Load regulation of V _{DD}	0	-	100	mV	I _{DD(ext)} = 0 - 1.0 mA, 500pF at GATE; R _T = 226kΩ, PWM_D = V _{DD}
U _{VLO}	V _{DD} under voltage lockout threshold*	6.0	-	6.95	V	V _{IN} rising
ΔU _{VLO}	V _{DD} under voltage lockout hysteresis	-	500	-	mV	V _{IN} falling
PWM Dimming						
V _{EN(lo)}	PWM_D input low voltage*	-	-	0.8	V	V _{IN} = 8.0 - 450V
V _{EN(hi)}	PWM_D input high voltage*	2.0	-	-	V	V _{IN} = 8.0 - 450V
R _{EN}	Internal pull-down resistance at PWM_D	50	100	150	kΩ	V _{PWMD} = 5.0V
-	PWM dimming frequency	-	-	500	Hz	-
Average Current Sense Logic						
V _{CS}	Current sense reference voltage *	264	-	280	mV	-
ΔV _(LD)	LD-to-CS voltage ratio*	0.17	-	0.19	-	-
V _{LD(OFF)}	LD input voltage, shutdown	-	150	-	mV	V _{LD} falling
A _{VLD(OFF)}	LD input voltage, enable	-	200	-	mV	V _{LD} rising
T _{BLANK}	Current sense blanking interval*	150	-	280	ns	-
T _{ON(min)}	Minimum on-time	-	-	1000	ns	CS = V _{CS} +30mV
D _{MAX}	Maximum steady-state duty cycle	75	-	-	%	Reduction in output LED current may occur beyond this duty cycle

Symbol	Description	Min	Typ	Max	Units	Conditions
Short Circuit Protection						
V _{CS}	Hiccup threshold voltage	410	-	470	mV	-
T _{DELAY}	Current limit delay CS-to-GATE	-	-	150	ns	CS = V _{CS} +30mV
T _{HICCU}	Short circuit hiccup time	-	395	-	μs	-
T _{ON(min)}	Minimum on-time (short circuit)	-	-	430	ns	CS = V _{DD}
T_{OFF} TIMER						
T _{OFF}	Off time	8	-	12	μs	R _T = 226 kΩ
		32	-	48		R _T = 1.00 MΩ
GATE Driver						
I _{SOURCE}	GATE sourcing current	0.165	-	-	A	V _{GATE} = 0V, V _{DD} = 7.5V
I _{SINK}	GATE sinking current	0.165	-	-	A	V _{GATE} = V _{dd} , V _{DD} = 7.5V
t _{RISE}	GATE output rise time	-	-	50	ns	C _{GATE} = 500pF, V _{DD} = 7.5V
t _{FALL}	GATE output fall time	-	-	50	ns	C _{GATE} = 500pF, V _{DD} = 7.5V
Notes						
1. Also limited by package power dissipation limit, whichever is lower.						
* Denotes the specifications which apply over the full operating ambient temperature range of -40°C < T _A < +125°C.						

Application Information

Peak-current control (as in IL9910) of a buck converter is the most economical and simple way to regulate its output current. However, it suffers accuracy and regulation problems that arise from the so-called peak-to-average current error, contributed by the current ripple in the output inductor and the propagation delay in the current sense comparator. The full inductor current signal is unavailable for direct sensing at the ground potential in a buck converter when the control switch is referenced to the same ground potential because the control switch is only conducting for small periods. While it is very simple to detect the peak current in the switch, controlling the average inductor current is usually implemented by level translating the sense signal from +V_{IN}. Though this is practical for relatively low input voltage V_{IN}, this type of average-current control may become excessively complex and expensive in the offline AC or other high voltage DC applications.

The IL3361 employs proprietary control scheme, achieving fast and very accurate control of average current in the buck inductor through sensing the switch current only. No compensation of the current control loop is required. The LED current response to PWM_D input is similar to that of the IL9910. The inductor current ripple amplitude does not affect this control scheme significantly, and therefore, the LED current is independent of the variation in inductance, switching frequency or output voltage. Constant off-time control of the buck converter is used for stability and to improve the LED current regulation over a wide range of input voltages. (Note that, unlike IL9910, the IL3361 does not support the constant-frequency mode of operation.)

The typical output characteristic of the IL3361 LED driver is shown in Figure 1. The corresponding IL9910 characteristic is given for the comparison.

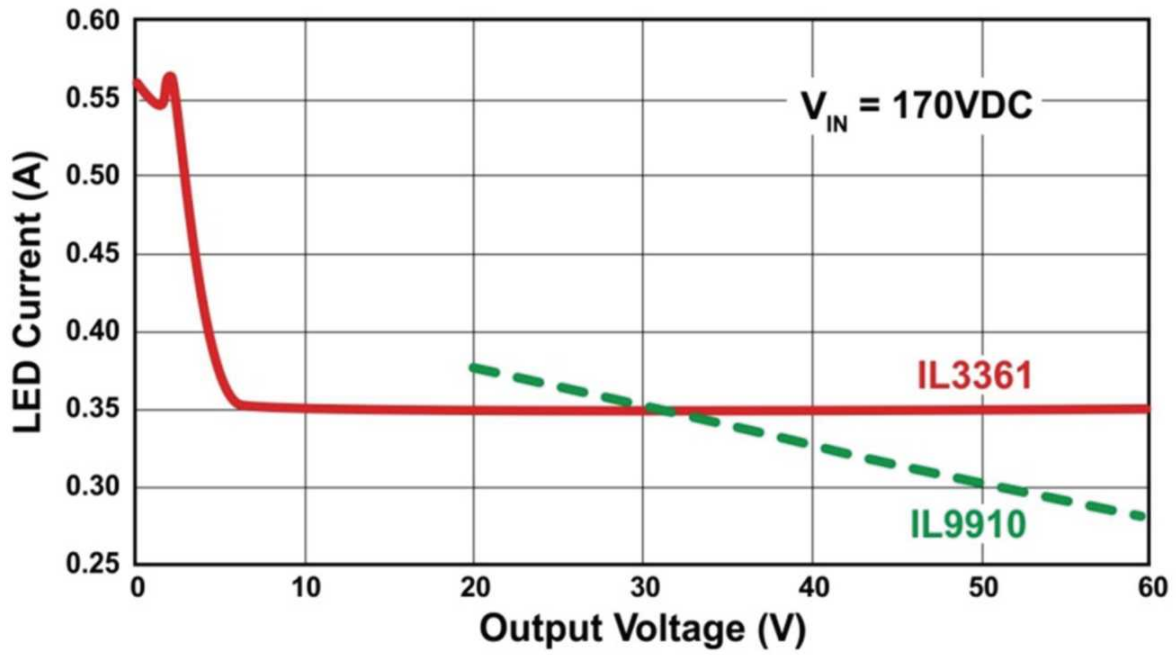
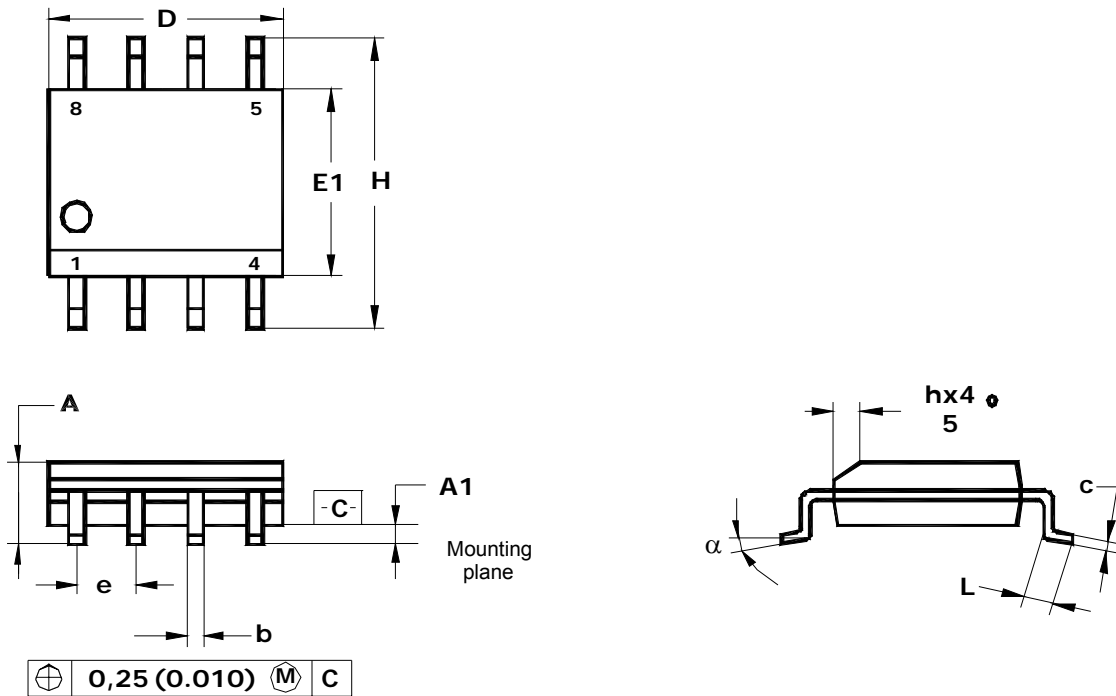

Figure 1 - Typical output characteristic of an IL3361 LED driver.

D SUFFIX PLASTIC SOP
(MS-012AA)



	D	E1	H	b	e	α	A	A1	c	L	h
mm											
min	4.80	3.80	5.80	0.33		0°	1.35	0.10	0.19	0.41	0.25
max	5.00	4.00	6.20	0.51	1.27	8°	1.75	0.25	0.25	1.27	0.50
inches											
min	0.1890	0.1497	0.2284	0.013		0°	0.0532	0.0040	0.0075	0.016	0.0099
max	0.1968	0.1574	0.2440	0.020	0.100	8°	0.0688	0.0090	0.0098	0.050	0.0196

DH SUFFIX PLASTIC SOP
(MS-012AC)

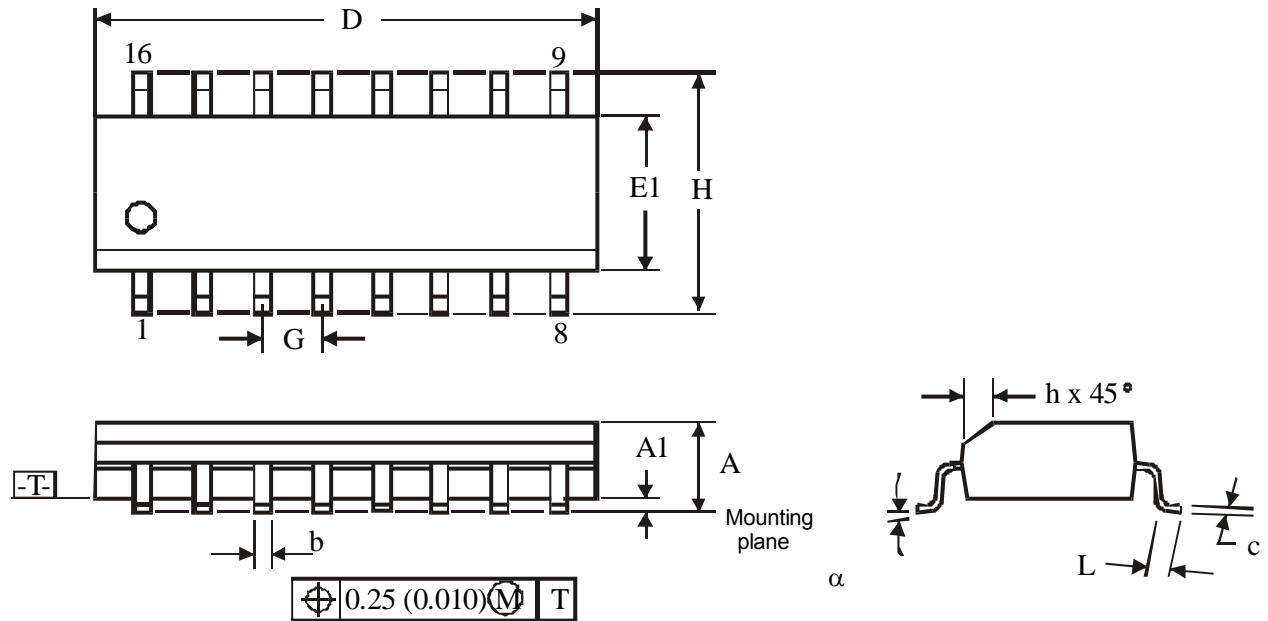

	D	E1	A	b	h	e	α	L	H	c	A1
mm											
min	9,80	3,80	1,35	0,33	0,25	1,27	0°	0,40	5,80	0,19	0,10
max	10,00	4,00	1,75	0,51	0,50		8°	1,27	6,20	0,25	0,25
inches											
min	0,386	0,150	0,053	0,013	0,010	0,050	0°	0,016	0,228	0,007	0,004
max	0,394	0,157	0,069	0,020	0,020		8°	0,050	0,244	0,010	0,010

Contact pad layout diagram:

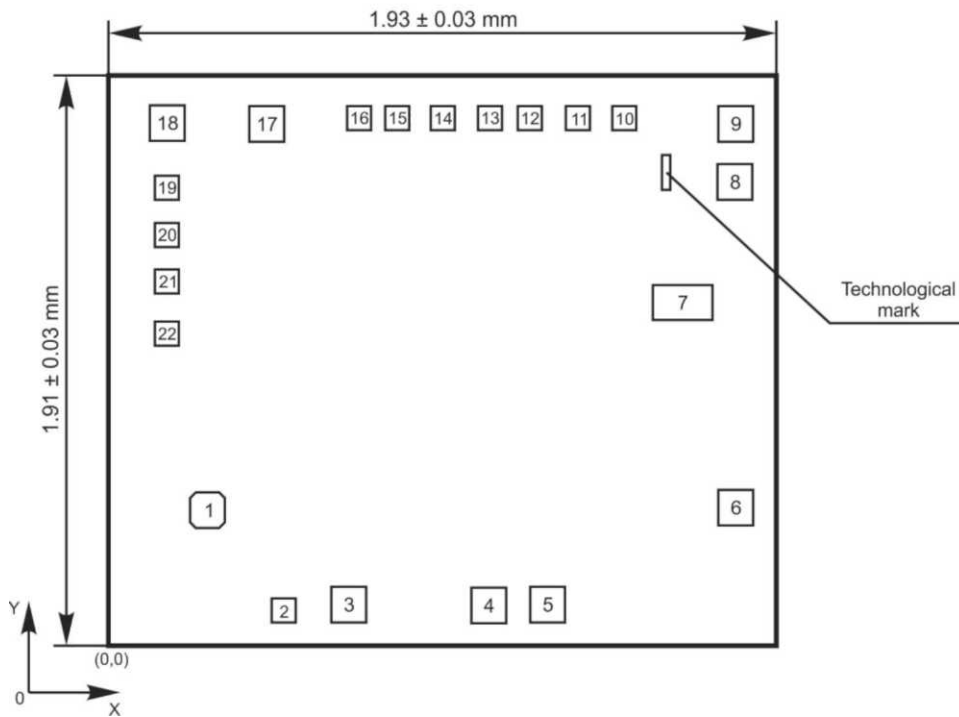

Die thickness 0.46±0.02 mm.

Technological mark coordinates, um: x=1617, y=1461.

Contact pad coordinates and sizes:

Contact pad number	Coordinates (left bottom corner*, um)		Contact pad dimension, um
	X	Y	
1	276	283	95x95
2	589	115	80x80
3	718	115	95x95
4	1015	115	95x95
5	1060	115	95x95
6	1700	406	95x95
7	1538	1025	190x95
8	1715	1515	95x95
9	1715	1700	95x95
10	1428	1715	80x80
11	1312	1715	80x80
12	1196	1715	80x80
13	1080	1715	80x80
14	964	1715	80x80
15	848	1715	80x80
16	732	1715	80x80
17	560	1700	95x95
18	115	1700	95x95
19	115	1560	80x80
20	115	1444	80x80
21	115	1328	80x80
22	115	1268	80x80

Note: Contact pad coordinates and dimensions are indicated under "Passivation" layer