

Power Factor Controllers

IL34262

There are active power factor controllers specifically designed for use as a preconverter in electronic ballast and in off-line power converter applications.

These integrated circuits feature an internal startup timer for stand-alone applications, a one quadrant multiplier for near unity power factor, zero current detector to ensure critical conduction operation, transconductance error amplifier, quick

start circuit for enhanced startup, trimmed internal bandgap reference, current sensing comparator, and a totem pole output ideally suited for driving a power MOSFET.

Also included are protective features consisting of an overvoltage comparator to eliminate runaway output voltage due to load removal, input undervoltage lockout with hysteresis, cycle-by-cycle current limiting, multiplier output clamp that limits maximum peak switch current, an RS latch for single pulse metering, and a drive output high state clamp for MOSFET gate protection. These devices are available in dual-in-line and surface mount plastic packages.

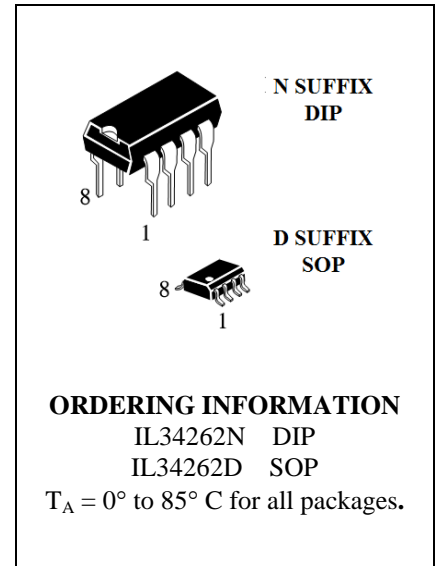

- Overvoltage Comparator Eliminates Runaway Output Voltage
- Internal Startup Timer
- One Quadrant Multiplier
- Zero Current Detector
- Trimmed 2% Internal Bandgap Reference
- Totem Pole Output with High State Clamp
- Undervoltage Lockout with 6.0 V of Hysteresis
- Low Startup and Operating Current
- Supersedes Functionality of SG3561, TDA4817 and MC34262

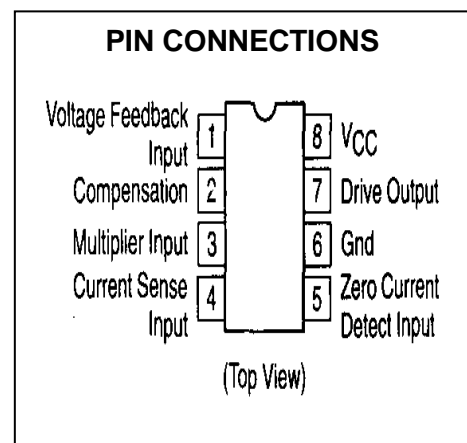

MAXIMUM RATINGS

Rating	Symbol	Value	Unit
Total Power Supply and Zener Current	(I _{cc} + I _z)	30	mA
Output Current, Source or Sink	I _o	500	mA
Current Sense, Multiplier, and Voltage Feedback Inputs	V _{in}	-1.0 to +10	V
Zero Current Detect Input	I _{in}		mA
High State Forward Current		50	
Low State Reverse Current		-10	
Power Dissipation and Thermal Characteristics			
N Suffix, Plastic Package			
Maximum Power Dissipation @ T _A = 70°C	P _D	800	mW
Thermal Resistance, Junction-to-Air	R _{θJA}	100	°C/W
D Suffix, Plastic Package			
Maximum Power Dissipation @ T _A = 70°C	P _D	450	mW
Thermal Resistance, Junction-to-Air	R _{θJA}	178	°C/W
Operating Junction Temperature	T _J	+150	°C
Operating Ambient Temperature	T _A	0 to + 85	°C
Storage Temperature	T _{stg}	-65 to +150	°C

* Stresses beyond those listed under “absolute maximum ratings” may cause permanent damage to the device. These are stress ratings only and functional operation of the device at these or any other conditions beyond those indicated under “recommended operating conditions” is not implied. Exposure to absolute-maximum-rated conditions for extended periods may affect device reliability.

ELECTRICAL CHARACTERISTICS (V_{cc} = 12 V, for min/max values T_A is the operating ambient temperature range that applies unless otherwise noted.)

Characteristic	Symbol	Min	Max	Unit
ERROR AMPLIFIER				
Voltage Feedback Input Threshold	V _{FB}			V
T _A = 25°C		2.465	2.535	
T _A = T low to T high (V _{cc} = 12 V to 28 V)		2.44	2.54	
Line Regulation (V _{cc} = 12 V to 28 V, T _A = 25°C)	Reg _{line}	—	10	mV
Input Bias Current (V _{FB} = 0 V)	I _{IB}	—	-0.5	µA
Transconductance (T _A = 25°C)	g _m	80	130	µmho
Output Current	I _o			µA
Source (V _{FB} = 2.3 V)		—	—	
Sink (V _{FB} = 2.7 V)		—	—	
Output Voltage Swing				V
High State (V _{FB} = 2.3 V)	V _{OH(ea)}	5.8	—	
Low State (V _{FB} = 2.7 V)	V _{OL(ea)}	—	2.4	

Characteristic	Symbol	Min	Max	Unit
OVERVOLTAGE COMPARATOR				
Voltage Feedback Input Threshold	$V_{FB(OV)}$	$1.065V_{FB}$	$1.095V_{FB}$	V
MULTIPLIER				
Input Bias Current, Pin 3 ($V_{FB} = 0$ V)	I_{IB}	—	-0.5	μ A
Input Threshold, Pin 2	$V_{th(M)}$	$1.05 V_{OL(EA)}$	—	V
Dynamic Input Voltage Range Multiplier Input (Pin 3)	V_{pin3}	0 to $2.5 V_{th(M)}$ to	—	V
Compensation (Pin 2)	V_{pin2}	$(V_{th(M)}+1.0)$	—	
Multiplier Gain ($V_{pin 3} = 0.5$ V, $V_{pin 2} = V_{th(M)} + 1.0$ V)	K	0.43	0.87	1/V
ZERO CURRENT DETECTOR				
Input Threshold Voltage (V_{jn} Increasing)	V_{th}	1.33	1.87	V
Hysteresis (V_{in} Decreasing)	V_H	100	300	mV
Input Clamp Voltage High State ($I_{DET} = + 3.0$ mA)	V_{IH}	6.1	—	V
Low State ($I_{DET} = - 3.0$ mA)	V_{IL}	0.3	1.0	
CURRENT SENSE COMPARATOR				
Input Bias Current ($V_{pin 4} = 0$ V)	I_{IB}	—	-1.0	μ A
Input Offset Voltage ($V_{pm 2} = 1.6$ V, $V_{pm 3} = 0$ V)	V_{IO}	—	25	mV
Maximum Current Sense Input Threshold (Note 1)	$V_{th(max)}$	1.3	1.8	V
Delay to Output	$t_{PHL(in/out)}$	—	400	ns
DRIVE OUTPUT				
Output Voltage ($V_{CC} = 12$ V) Low State ($I_{sink} = 20$ mA)	V_{OL}	—	0.8	V
($I_{sink} = 200$ mA)		—	3.3	
High State ($I_{source} = 20$ mA)	V_{OH}	9.8	0.8	
($I_{source} = 200$ mA)		7.8	3.3	
Output Voltage ($V_{CC} = 30$ V) High State ($I_{source} = 20$ mA, $C_L = 15$ pF)	$V_{O(max)}$	14	18	V
Output Voltage Rise Time ($C_L = 1.0$ nF)	t_r	—	120	ns
Output Voltage Fall Time ($C_L = 1.0$ nF)	t_f	—	120	ns
Output Voltage with UVLO Activated ($V_{CC} = 7.0$ V, $I_{Sink} = 1.0$ mA)	$V_{O(UVLO)}$	—	0.5	V
RESTART TIMER				
Restart Time Delay	t_{DLY}	200	—	μ s

Note 1: This parameter is measured with $V_{FB} = 0$ V, and $V_{Pin3} = 3.0$ V

Characteristic	Symbol	Min	Max	Unit
UNDERVOLTAGE LOCKOUT				
Startup Threshold (V_{CC} Increasing)	$V_{th(on)}$	11.5	14.5	V
Minimum Operating Voltage After Turn-On (V_{CC} Decreasing)	$V_{Shutdown}$	7.0	9.0	V
Hysteresis	V_H	3.8	6.2	V
TOTAL DEVICE				
Power Supply Current	I_{CC}	—	0.4	mA
Startup ($V_{CC} = 7.0$ V)			12	
Operating Dynamic Operating (50 kHz, $C_L = 1.0$ nF)			20	
Power Supply Zener Voltage ($I_{ce} = 25$ mA)	V_Z	30	—	V

Simplified Block Diagram

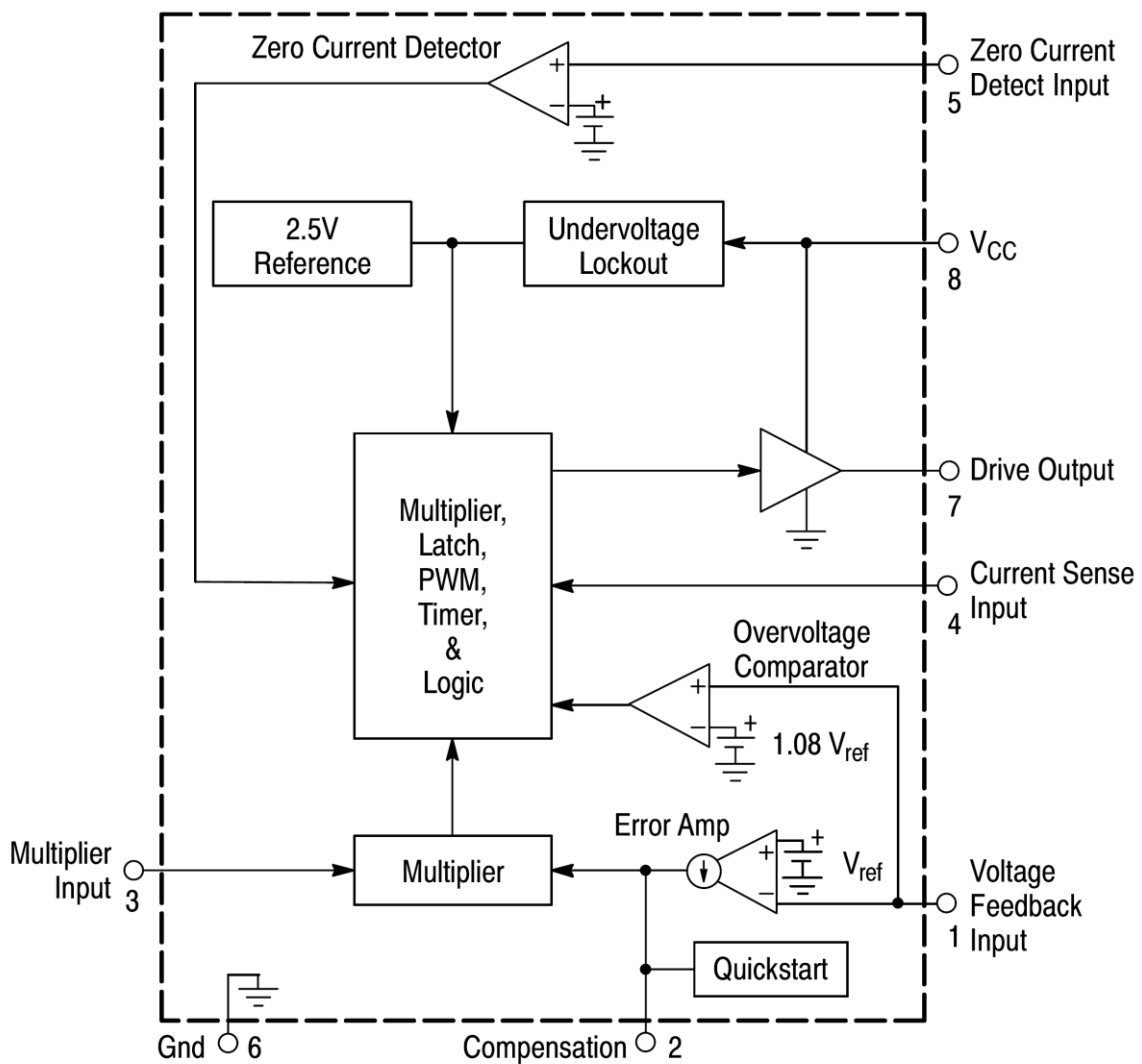

Notes	Calculation	Formula
Calculate the maximum required output power.	Required Converter Output Power	$P_O = V_O I_O$
Calculated at the minimum required ac line voltage for output regulation. Let the efficiency $\eta = 0.92$ for low line operation.	Peak Inductor Current	$I_{L(pk)} = \frac{2\sqrt{2} P_O}{\eta V_{ac(LL)}}$
Let the switching cycle $t = 40 \mu s$ for universal input (85 to 265 Vac) operation and $20 \mu s$ for fixed input (92 to 138 Vac, or 184 to 276 Vac) operation.	Inductance	$L_P = \frac{t \left(\frac{V_O}{\sqrt{2}} - V_{ac(LL)} \right) \eta V_{ac(LL)}^2}{\sqrt{2} V_O P_O}$
In theory the on-time t_{on} is constant. In practice t_{on} tends to increase at the ac line zero crossings due to the charge on capacitor C_5 . Let $V_{ac} = V_{ac(LL)}$ for initial t_{on} and t_{off} calculations.	Switch On-Time	$t_{on} = \frac{2 P_O L_P}{\eta V_{ac}^2}$
The off-time t_{off} is greatest at the peak of the ac line voltage and approaches zero at the ac line zero crossings. Theta (θ) represents the angle of the ac line voltage.	Switch Off-Time	$t_{off} = \frac{t_{on}}{\frac{V_O}{\sqrt{2} V_{ac} \sin \theta } - 1}$
The minimum switching frequency occurs at the peak of the ac line voltage. As the ac line voltage traverses from peak to zero, t_{off} approaches zero producing an increase in switching frequency.	Switching Frequency	$f = \frac{1}{t_{on} + t_{off}}$
Set the current sense threshold V_{CS} to 1.0 V for universal input (85 Vac to 265 Vac) operation and to 0.5 V for fixed input (92 Vac to 138 Vac, or 184 Vac to 276 Vac) operation. Note that V_{CS} must be <1.4 V.	Peak Switch Current	$R_7 = \frac{V_{CS}}{I_{L(pk)}}$
Set the multiplier input voltage V_M to 3.0 V at high line. Empirically adjust V_M for the lowest distortion over the ac line voltage range while guaranteeing startup at minimum line.	Multiplier Input Voltage	$V_M = \frac{V_{ac} \sqrt{2}}{\left(\frac{R_5}{R_3} + 1 \right)}$
The $I_{IB} R_1$ error term can be minimized with a divider current in excess of 50 μA .	Converter Output Voltage	$V_O = V_{ref} \left(\frac{R_2}{R_1} + 1 \right) - I_{IB} R_2$
The calculated peak-to-peak ripple must be less than 16% of the average dc output voltage to prevent false tripping of the Overvoltage Comparator. Refer to the Overvoltage Comparator text. ESR is the equivalent series resistance of C_3	Converter Output Peak to Peak Ripple Voltage	$\Delta V_{O(pp)} = I_O \sqrt{\left(\frac{1}{2\pi f_{ac} C_3} \right)^2 + ESR^2}$
The bandwidth is typically set to 20 Hz. When operating at high ac line, the value of C_1 may need to be increased. (See Figure 25)	Error Amplifier Bandwidth	$BW = \frac{gm}{2\pi C_1}$

The following converter characteristics must be chosen:

- V_O — Desired output voltage V_{ac} — AC RMS line voltage
- I_O — Desired output current $V_{ac(LL)}$ — AC RMS low line voltage
- ΔV_O — Converter output peak-to-peak ripple voltage

<Design Equations>

APPLICATION INFORMATION

The application circuits shown in Figures 1, 2 and 3 reveal that few external components are required for a complete power factor preconverter. Each circuit is a peak detecting current-mode boost converter that operates in critical conduction mode with a fixed on-time and variable off-time. A major benefit of critical conduction operation is that the current loop is inherently stable, thus eliminating the need for ramp compensation. The application in Figure 1 operates over an input voltage range of 90 Vac to 138 Vac and provides an

output power of 80W (230V at 350mA) with an associated power factor of approximately 0.998 at nominal line. Figures 2 and 3 are universal input preconverter examples that operate over a continuous input voltage range of 90 Vac to 268Vac. Figure 2 provides an output power of 175W (400V at 440mA) while Figure 3 provides 450W (400V at 1.125A). Both circuits have an observed worst-case power factor of approximately 0.989.

Figure 1. 80W Power Factor Controller

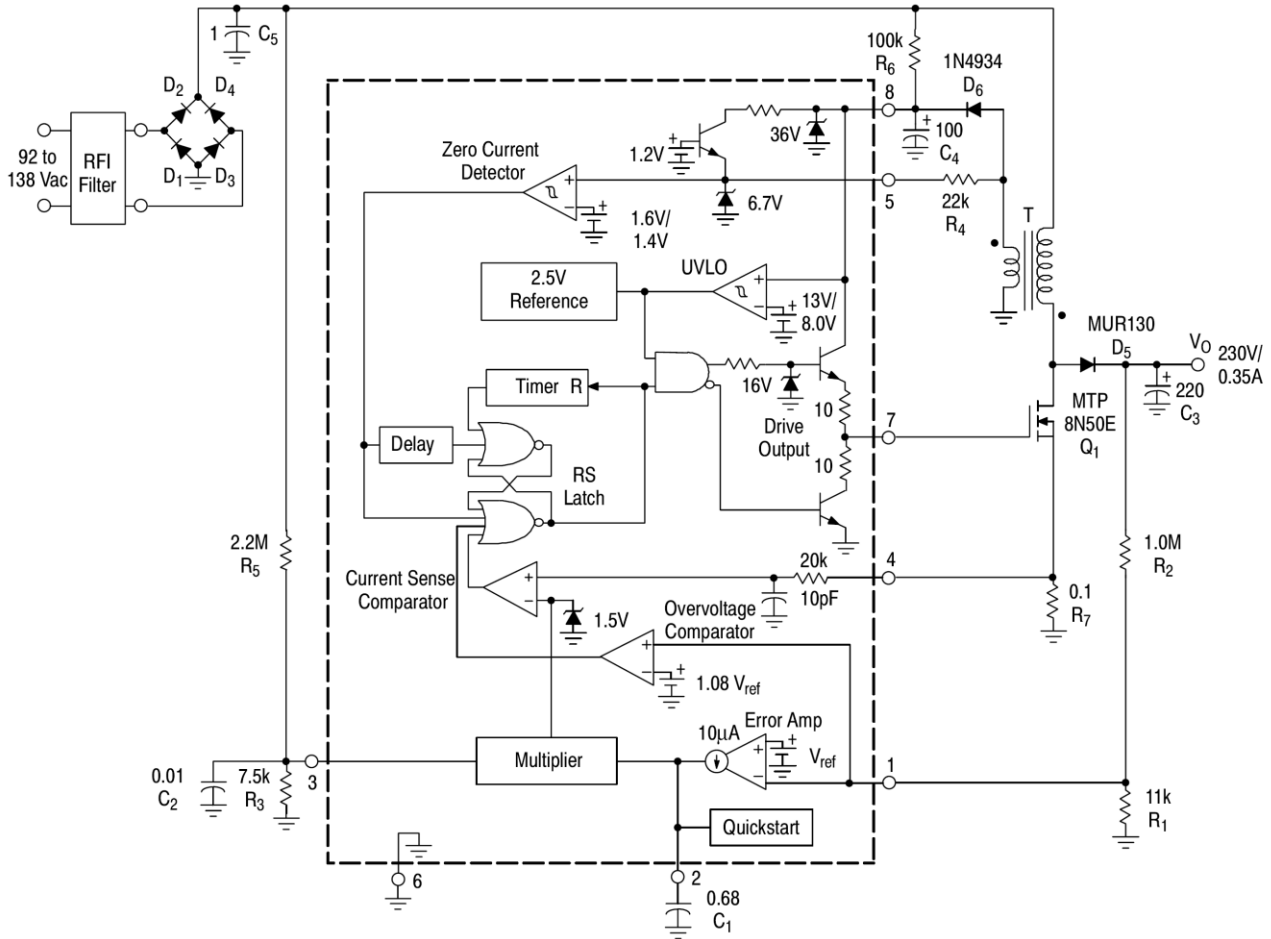

Power Factor Controller Test Data

V _{rms}	AC Line Input								DC Output				
	P _{in}	PF	I _{fund}	Current Harmonic Distortion (% I _{fund})					V _{O(pp)}	V _O	I _O	P _O	η(%)
				THD	2	3	5	7					
90	85.9	0.999	0.93	2.6	0.08	1.6	0.84	0.95	4.0	230.7	0.350	80.8	94.0
100	85.3	0.999	0.85	2.3	0.13	1.0	1.2	0.73	4.0	230.7	0.350	80.8	94.7
110	85.1	0.998	0.77	2.2	0.10	0.58	1.5	0.59	4.0	230.7	0.350	80.8	94.9
120	84.7	0.998	0.71	3.0	0.09	0.73	1.9	0.58	4.1	230.7	0.350	80.8	95.3
130	84.4	0.997	0.65	3.9	0.12	1.7	2.2	0.61	4.1	230.7	0.350	80.8	95.7
138	84.1	0.996	0.62	4.6	0.16	2.4	2.3	0.60	4.1	230.7	0.350	80.8	96.0

Figure 2. 175W Universal Input Power Factor Controller

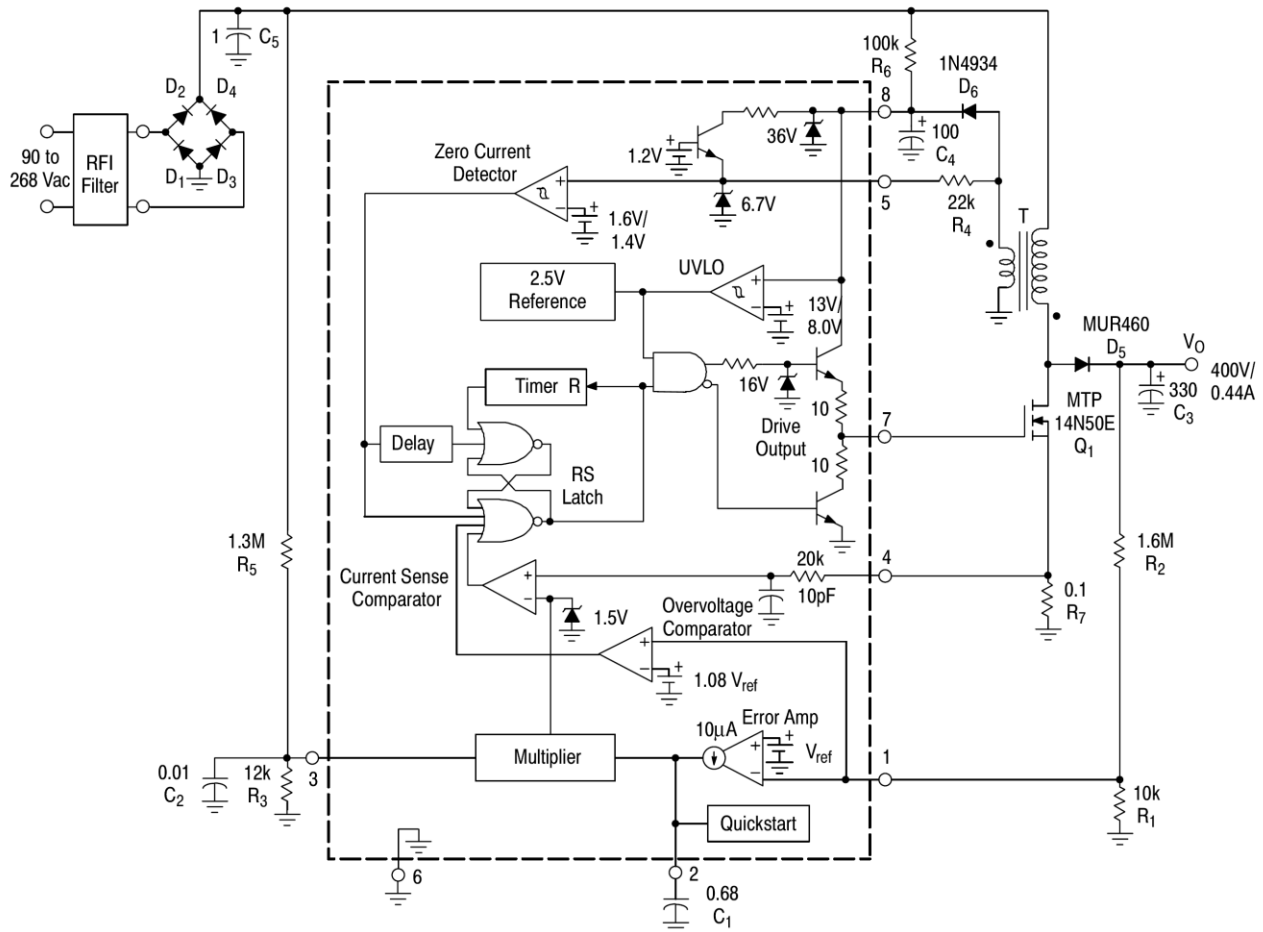

Power Factor Controller Test Data

		AC Line Input							DC Output				
V_{rms}	P_{in}	PF	I_{fund}	Current Harmonic Distortion (% I_{fund})					$V_{O(pp)}$	V_O	I_O	P_O	$\eta(\%)$
				THD	2	3	5	7					
90	193.3	0.991	2.15	2.8	0.18	2.6	0.55	1.0	3.3	402.1	0.44	176.9	91.5
120	190.1	0.998	1.59	1.6	0.10	1.4	0.23	0.72	3.3	402.1	0.44	176.9	93.1
138	188.2	0.999	1.36	1.2	0.12	1.3	0.65	0.80	3.3	402.1	0.44	176.9	94.0
180	184.9	0.998	1.03	2.0	0.10	0.49	1.2	0.82	3.4	402.1	0.44	176.9	95.7
240	182.0	0.993	0.76	4.4	0.09	1.6	2.3	0.51	3.4	402.1	0.44	176.9	97.2
268	180.9	0.989	0.69	5.9	0.10	2.3	2.9	0.46	3.4	402.1	0.44	176.9	97.8

Figure 3. 450W Universal Input Power Factor Controller

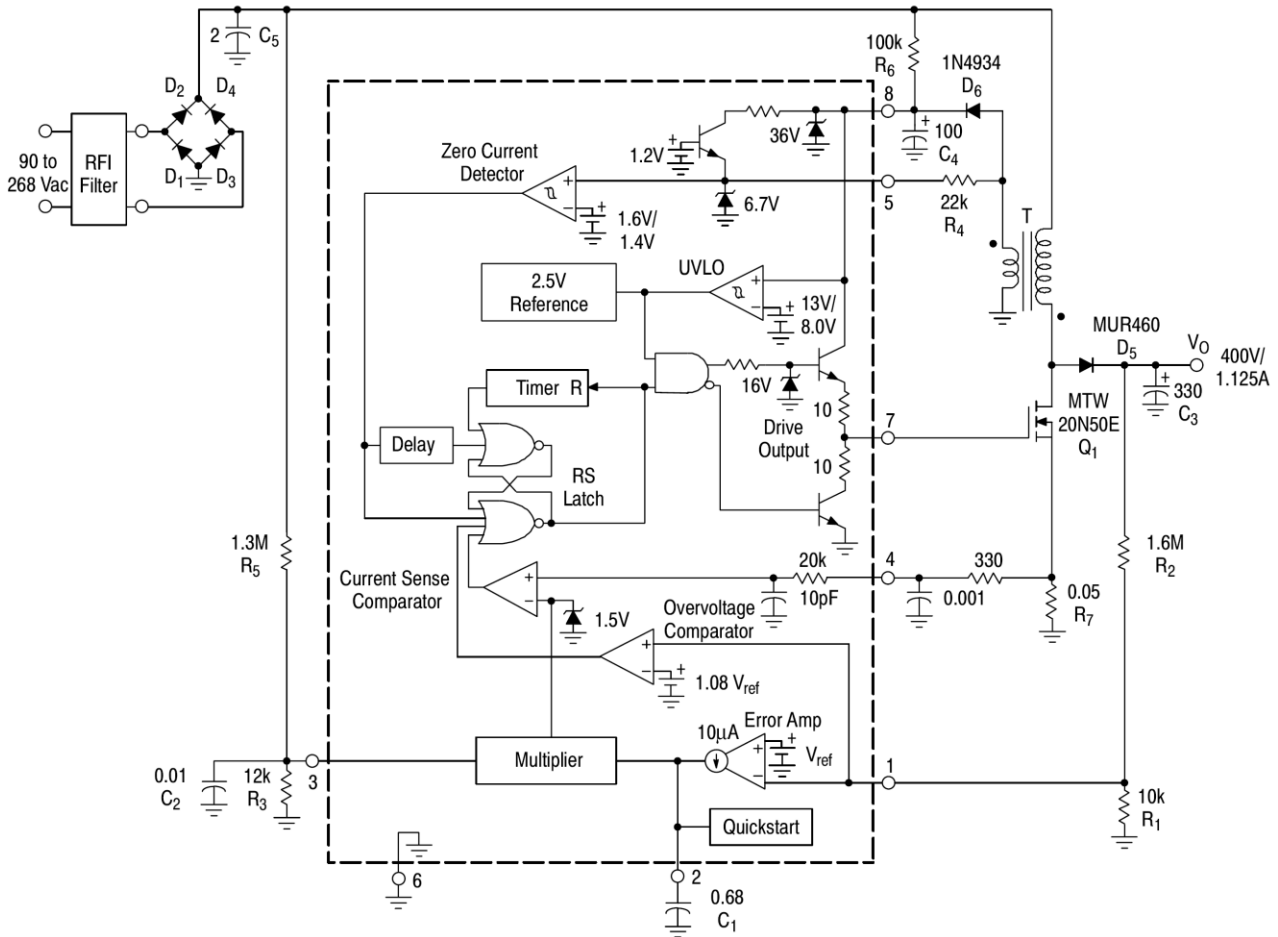

Power Factor Controller Test Data

V _{rms}	P _{in}	PF	I _{fund}	AC Line Input					DC Output				
				Current Harmonic Distortion (% I _{fund})					V _{O(pp)}	V _O	I _O	P _O	η(%)
				THD	2	3	5	7					
90	489.5	0.990	5.53	2.2	0.10	1.5	0.25	0.83	8.8	395.5	1.14	450.9	92.1
120	475.1	0.998	3.94	2.5	0.12	0.29	0.62	0.52	8.8	395.5	1.14	450.9	94.9
138	470.6	0.998	3.38	2.1	0.06	0.70	1.1	0.41	8.8	395.5	1.14	450.9	95.8
180	463.4	0.998	2.57	4.1	0.21	2.0	1.6	0.71	8.9	395.5	1.14	450.9	97.3
240	460.1	0.996	1.91	4.8	0.14	4.3	2.2	0.63	8.9	395.5	1.14	450.9	98.0
268	459.1	0.995	1.72	5.8	0.10	5.0	2.5	0.61	8.9	395.5	1.14	450.9	98.2

N SUFFIX DIP
(MS – 001BA)

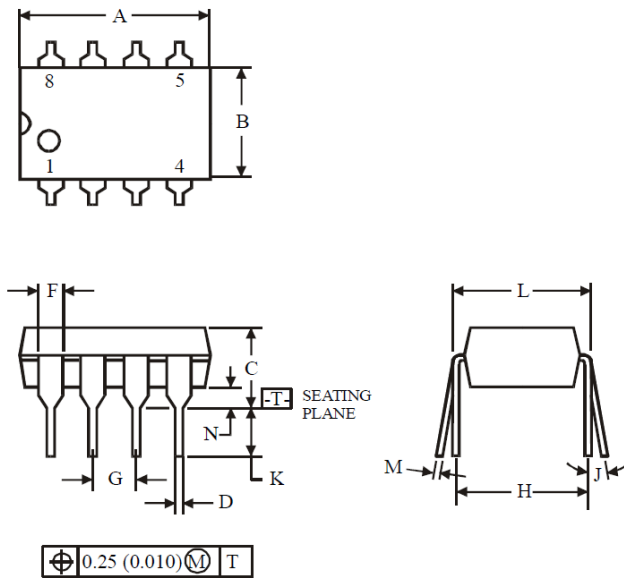
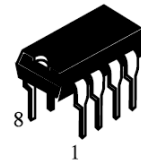

Dimension, mm		
Symbol	MIN	MAX
A	8.51	10.16
B	6.10	7.11
C		5.33
D	0.36	0.56
F	1.14	1.78
G	2.54	
H	7.62	
J	0°	10°
K	2.92	3.81
L	7.62	8.26
M	0.20	0.36
N	0.38	

NOTES:

- Dimensions “A”, “B” do not include mold flash or protrusions.
Maximum mold flash or protrusions 0.25 mm (0.010) per side.

D SUFFIX SOP
(MS - 012AA)

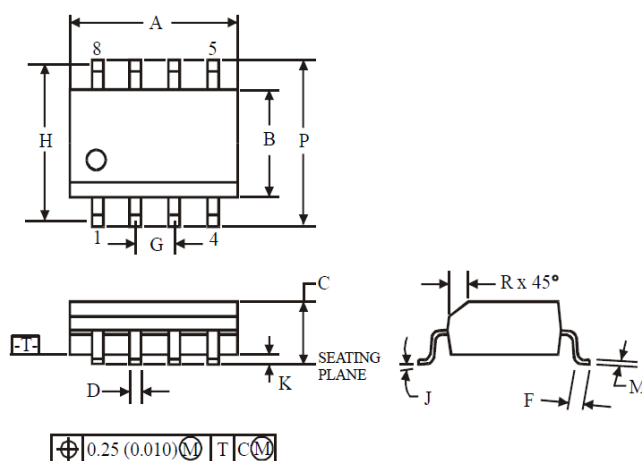

Dimension, mm		
Symbol	MIN	MAX
A	4.80	5.00
B	3.80	4.00
C	1.35	1.75
D	0.33	0.51
F	0.40	1.27
G	1.27	
H	5.72	
J	0°	8°
K	0.10	0.25
M	0.19	0.25
P	5.80	6.20
R	0.25	0.50

NOTES:

- Dimensions A and B do not include mold flash or protrusion.
- Maximum mold flash or protrusion 0.15 mm (0.006) per side for A; for B - 0.25 mm (0.010) per side.