

Low Voltage Audio Power AMP

IL386

The IL386 is a power amplifier designed for use in low voltage consumer applications. The gain is internally set to 20 to keep external part count low, but the addition of an external resistor and capacitor between pins 1 and 8 will increase the gain to any value up to 200.

The inputs are ground referenced while the output is automatically biased to one half the supply voltage. The quiescent power drain is only 24 milliwatts when operating from a 6 volt supply, making the IL386 ideal for battery operation.

- Battery Operation
- Minimum External Parts
- Wide Supply Voltage Range: 4 V - 12 V
- Low Quiescent Current Drain: 4 mA
- Voltage Gains from 20 to 200
- Ground Referenced Input
- Self-Centering Output Quiescent Voltage
- Low Distortion
- Eight Pin Dual-In-Line Package

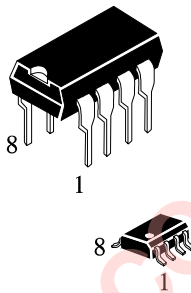

N SUFFIX PLASTIC

D SUFFIX SOIC

ORDERING INFORMATION
 IL386N Plastic
 IL386D SOIC
 T_A = 0° to 70° C for package

LOGIC DIAGRAM

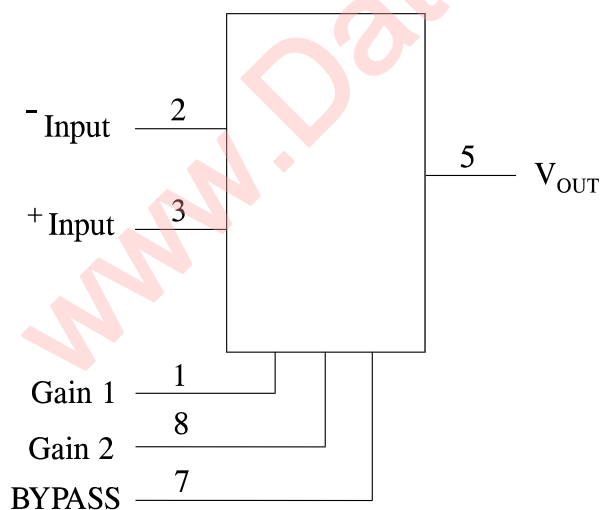

Pin 4 = GND
 Pin 6 = Supply Voltage V⁺

PIN ASSIGNMENT

GAIN	1 ●	8	GAIN
-INPUT	2	7	BYPASS
+INPUT	3	6	V ⁺
GND	4	5	V _{OUT}

MAXIMUM RATINGS*

Symbol	Parameter	Value	Unit
V _{CC}	Supply Voltage	15	V
V _{IN}	Input Voltage	±0.4	V
P _D	Power Dissipation	1.25	W
T _{stg}	Storage Temperature	-65 to +150	°C
T _J	Junction Temperature	+150	°C
T _L	Lead Temperature	+300	°C

*Maximum Ratings are those values beyond which damage to the device may occur. Functional operation should be restricted to the Recommended Operating Conditions.

RECOMMENDED OPERATING CONDITIONS

Symbol	Parameter	Min	Max	Unit
V _{CC}	Supply Voltage	4.0	12	V
T _A	Operating Temperature, All Package Types	0	+70	°C

This device contains protection circuitry to guard against damage due to high static voltages or electric fields. However, precautions must be taken to avoid applications of any voltage higher than maximum rated voltages to this high-impedance circuit. For proper operation, V_{IN} and V_{OUT} should be constrained to the range GND ≤ (V_{IN} or V_{OUT}) ≤ V_{CC}.

Unused inputs must always be tied to an appropriate logic voltage level (e.g., either GND or V_{CC}). Unused outputs must be left open.

ELECTRICAL CHARACTERISTICS (T_A = 25°C)

Symbol	Parameter	Test Conditions	Guaranteed Limits			Unit
			Min	Typ	Max	
V ⁺	Operating Supply Voltage		4		12	V
I ⁺	Quiescent Current	V ⁺ = 6 V, V _{IN} = 0			8	mA
P _O	Output Power	V ⁺ = 6V, R _L = 8Ω, THD=10% V ⁺ = 9V, R _L = 8Ω, THD=10%		325 1000		mW
A _V	Voltage Gain	V ⁺ = 6V, f=1kHz 10μF from Pin 1 and 8		26 46		dB
BW	Bandwidth	V ⁺ = 6V, Pins 1 and 8 Open	250			KHz
THD	Total Harmonic Distortion	V ⁺ = 6V, R _L = 8Ω, P _{OUT} =125mW, f=1kHz, Pins 1 and 8 Open			1.0	%
PSRR	Power Supply Rejection Ratio	V ⁺ = 6V, f=1kHz, C _{BYPASS} =10μF, Pins 1 and 8 Open		45		dB
R _{IN}	Input Resistance		30		80	KΩ
I _B	Input Bias Current	V ⁺ = 6V, Pins 2 and 3 Open		250		nA

APPLICATION INFORMATION

GAIN CONTROL

To make the IL386 a more versatile amplifier, two pins (1 and 8) are provided for gain control. With pins 1 and 8 open the 1.35 K Ω resistor sets the gain at 20 (26 dB). If a capacitor is put from pin 1 to 8, bypassing the 1.35 K Ω resistor, the gain will go up to 200 (46 dB). If a resistor is placed in series with the capacitor, the gain can be set to any value from 20 to 200. Gain control can also be done by capacitively coupling a resistor (or FET) from pin 1 to ground.

Additional external components can be placed in parallel with the internal feedback resistors to tailor the gain and frequency response for individual applications. For example, we can compensate poor speaker bass response by frequency shaping the feedback path. This is done with a series RC from pin 1 to 5 (paralleling the internal 15 K Ω resistor). For 6 dB effective bass boost: $R \approx 15$ K Ω , the lowest value for good stable operation is $R = 10$ K Ω if pin 8 is open. If pins 1 and 8 are bypassed then R as low as 2 K Ω can be used. This restriction is because the amplifier is only compensated for closed-loop gains greater than 9.

INPUT BIASING

The schematic shows that both inputs are biased to ground with a 50 K Ω resistor. The base current of the input transistors is about 250 nA, so the inputs are at about 12.5 mV when left open. If the dc source resistance driving the IL386 is higher than 250 K Ω it will contribute very little additional offset (about 2.5 mV at the input, 50 mV at the output). If the dc source resistance is less than 10 K Ω , then shorting the unused input to ground will keep the offset low (about 2.5 mV at the input, 50 mV at the output). For dc source resistances between these values we can eliminate excess offset by putting a resistor from the unused input to ground, equal in value to the dc source resistance. Of course all offset problems are eliminated if the input is capacitively coupled.

When using the IL386 with higher gains (by passing the 1.35 K Ω resistor between pins 1 and 8) it is necessary to bypass the unused input, preventing degradation of gain and possible instabilities. This is done with a 0.1 μ F capacitor or a short to ground depending on the dc source resistance on the driven input.

SCHEMATIC DIAGRAM

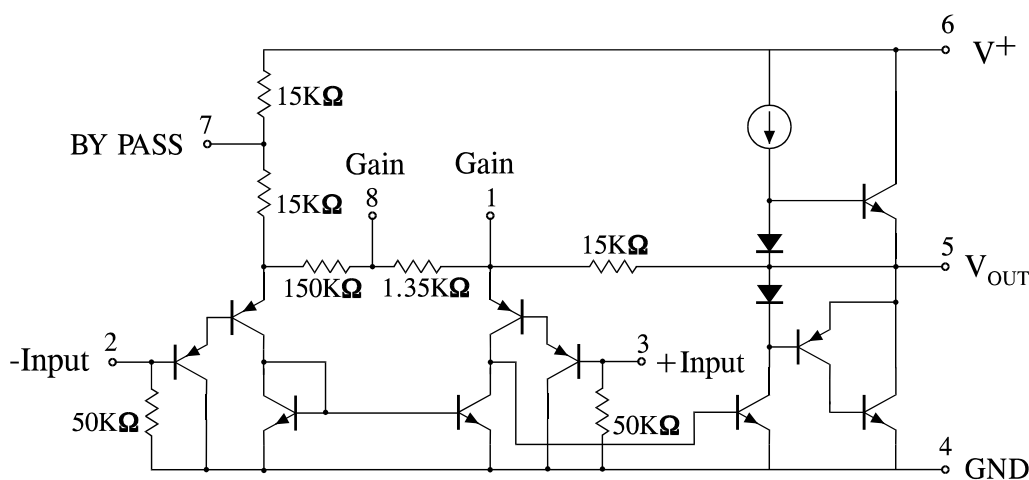

**N SUFFIX PLASTIC DIP
(MS - 001BA)**

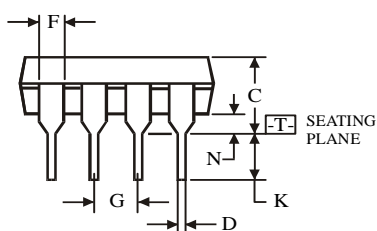
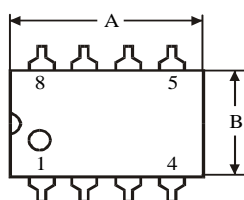
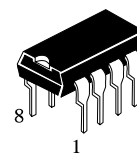

$\oplus 0.25 (0.010) \text{ (M) T}$

Symbol	Dimension, mm	
	MIN	MAX
A	8.51	10.16
B	6.1	7.11
C		5.33
D	0.36	0.56
F	1.14	1.78
G	2.54	
H	7.62	
J	0°	10°
K	2.92	3.81
L	7.62	8.26
M	0.2	0.36
N	0.38	

NOTES:

- Dimensions "A", "B" do not include mold flash or protrusions.
Maximum mold flash or protrusions 0.25 mm (0.010) per side.

**D SUFFIX SOIC
(MS - 012AA)**

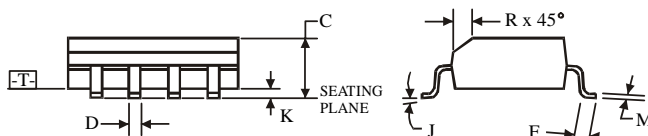
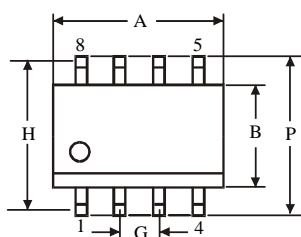
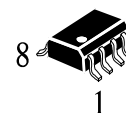

$\oplus 0.25 (0.010) \text{ (M) T C (M)}$

Symbol	Dimension, mm	
	MIN	MAX
A	4.8	5
B	3.8	4
C	1.35	1.75
D	0.33	0.51
F	0.4	1.27
G	1.27	
H	5.72	
J	0°	8°
K	0.1	0.25
M	0.19	0.25
P	5.8	6.2
R	0.25	0.5

NOTES:

- Dimensions A and B do not include mold flash or protrusion.
- Maximum mold flash or protrusion 0.15 mm (0.006) per side
for A; for B - 0.25 mm (0.010) per side.