

GAIN CONTROLLED MICROPHONE PREAMPLIFIER/VOGAD

The IL 6270 is a silicon integrated circuit combining the functions of audio amplifier and voice operated gain adjusting device (VOGAD). It is designed to accept signals from a low sensitivity microphone and to provide an essentially constant output signal for a 50dB range of input. The dynamic range, attack and decay times are controlled by external components.

FEATURES

- Constant Output Signal
- Fast Attack
- Low Power Consumption
- Simple Circuitry

APPLICATIONS

- Audio AGC Systems
- Transmitter Overmodulation Protection
- Tape recorders

QUICK REFERENCE DATA

- Supply Voltage: 4.5V to 10V
- Voltage Gain: 52dB

ABSOLUTE MAXIMUM RATINGS

- Supply Voltage: 12V
- Storage Temperature: -55°C to +125°C

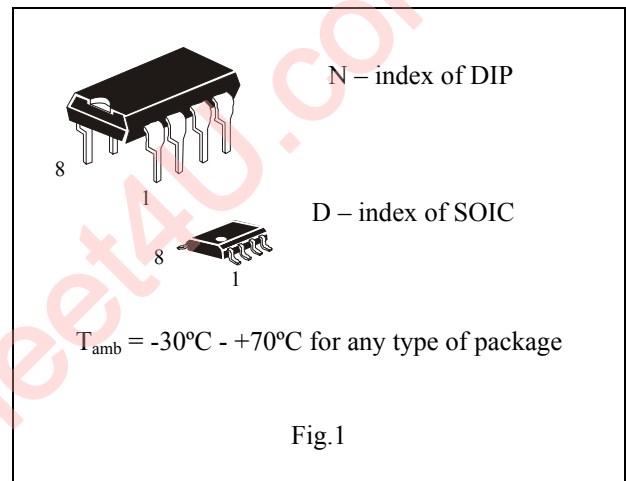

Fig.1

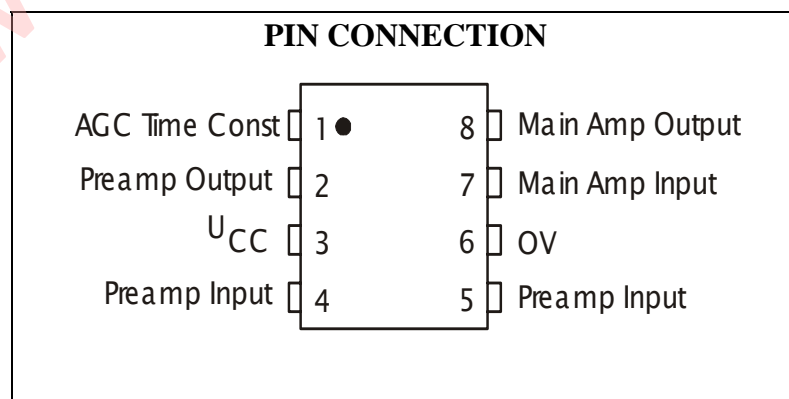

Fig.2

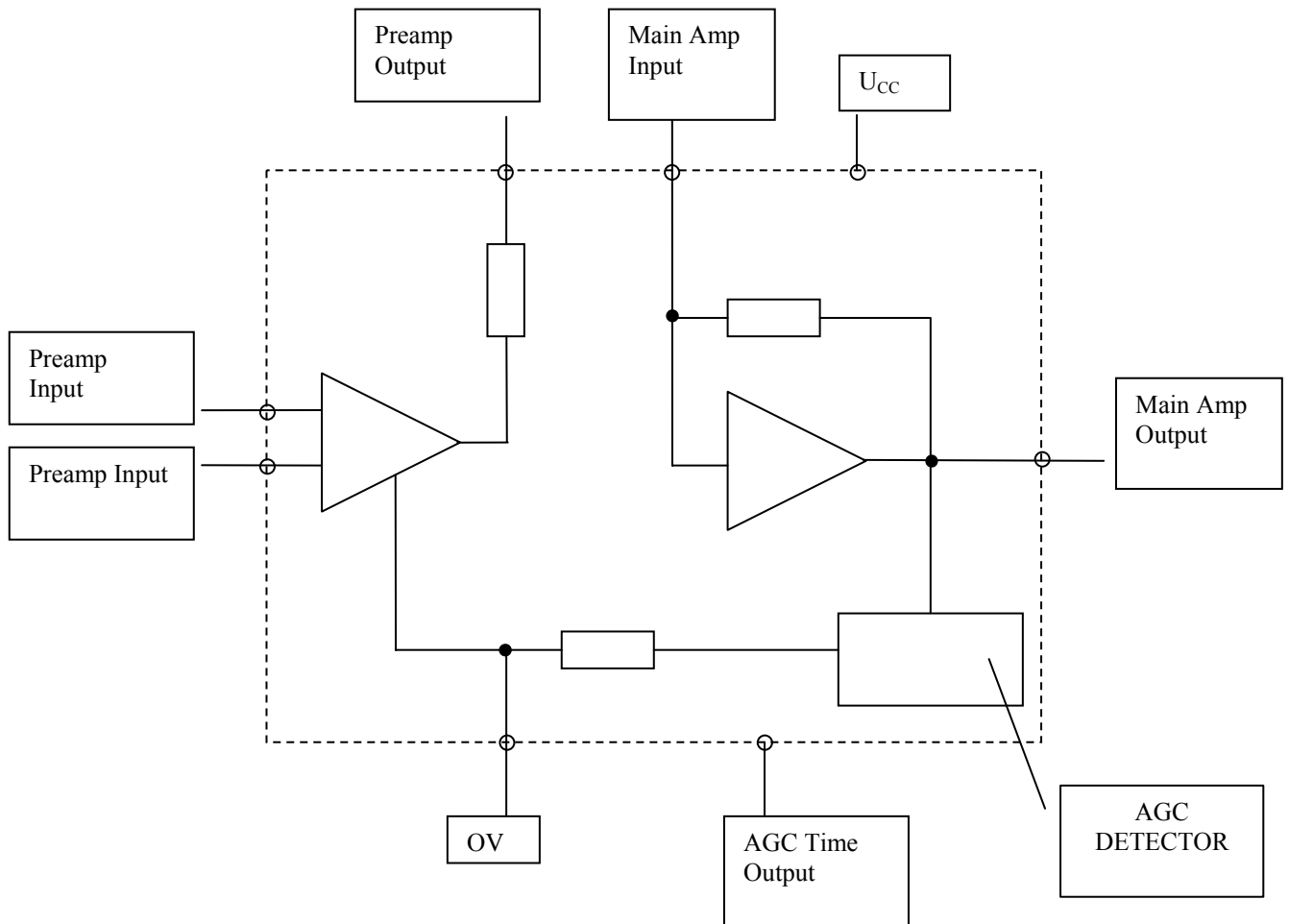
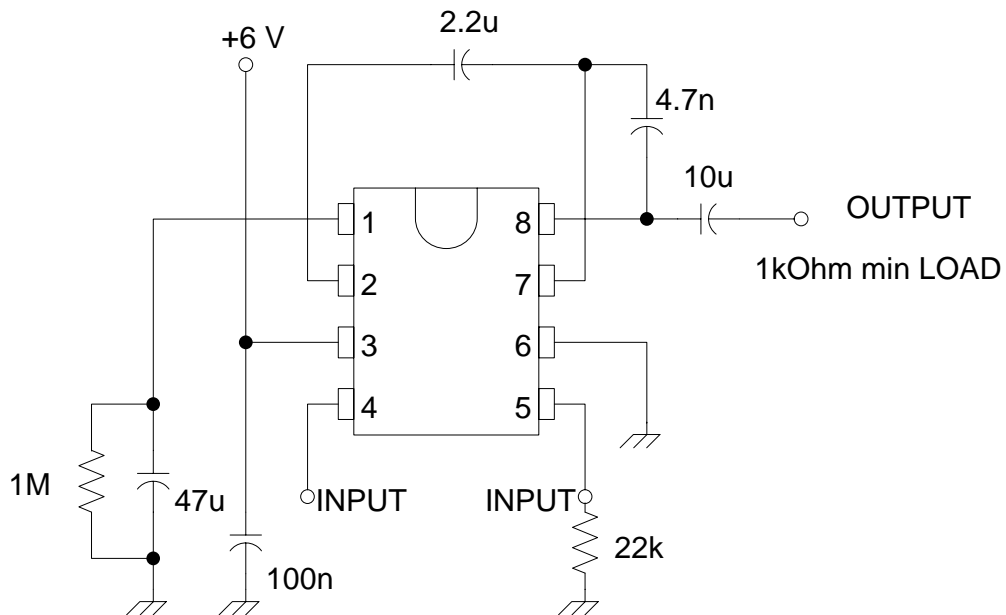

Fig.3 IL6270 block diagram

ELECTRICAL CHARACTERISTICS(U_{CC}=6V, F_I=1kHz, T_{amb}=-30°C to +85°C)

Characteristics	Conditions	Value			Units
		Min	Typ.	Max	
Supply current			5	10	mA
Input impedance	Pin 5 or 6		150		Ohm
Differential input impedance			300		Ohm
Voltage gain	72mV rms input pin 4	40	52		dB
Output level	4mV rms input pin 4	55	90	140	mV rms
THD	90mV rms input pin 4		2	5	%
Equivalent noise input voltage	F _I =400Гц до 25kHz R _I =300Ohm		1		mkV



N. B. If input not AC coupled the resistance between pins 4 and 5 must be less than 10 Ohms

Fig.4 IL6270 test and application circuit

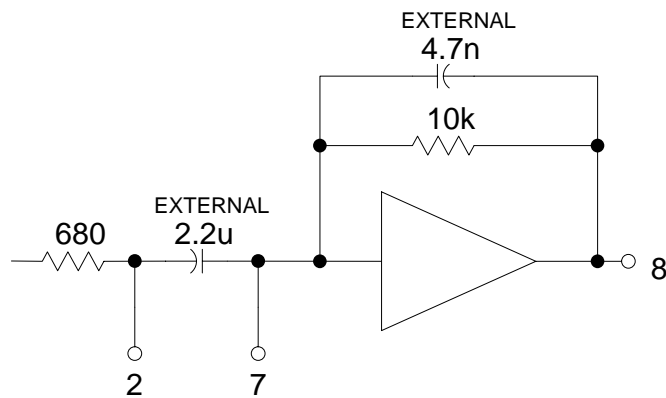

$$\text{Voltage gain} = \frac{10 \text{ k}\Omega}{680 \text{ }\Omega}$$

Upper frequency response $10\text{k}\Omega/4.7\text{nF} = 3\text{kHz}$
 Lower frequency response $680 \text{ }\Omega/2.2\mu\text{F} = 300\text{Hz}$

Fig.5 IL6270 frequency response

**N SUFFIX PLASTIC DIP
(MS - 001BA)**

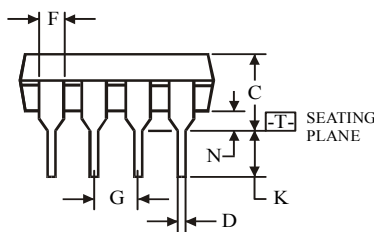
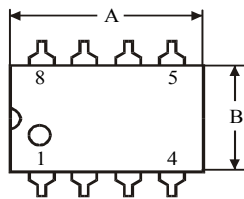
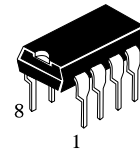

$\oplus 0.25 (0.010) \text{ (M) T}$

Symbol	Dimension, mm	
	MIN	MAX
A	8.51	10.16
B	6.1	7.11
C		5.33
D	0.36	0.56
F	1.14	1.78
G	2.54	
H	7.62	
J	0°	10°
K	2.92	3.81
L	7.62	8.26
M	0.2	0.36
N	0.38	

NOTES:

- Dimensions "A", "B" do not include mold flash or protrusions.
Maximum mold flash or protrusions 0.25 mm (0.010) per side.

**D SUFFIX SOIC
(MS - 012AA)**

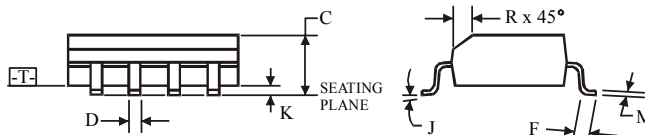
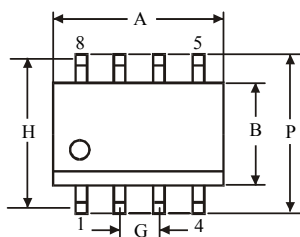
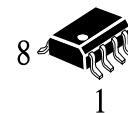

$\oplus 0.25 (0.010) \text{ (M) T C (M)}$

Symbol	Dimension, mm	
	MIN	MAX
A	4.8	5
B	3.8	4
C	1.35	1.75
D	0.33	0.51
F	0.4	1.27
G	1.27	
H	5.72	
J	0°	8°
K	0.1	0.25
M	0.19	0.25
P	5.8	6.2
R	0.25	0.5

NOTES:

- Dimensions A and B do not include mold flash or protrusion.
- Maximum mold flash or protrusion 0.15 mm (0.006) per side for A; for B - 0.25 mm (0.010) per side.