

IL9010N, IL9010D

IC of collector electric motor controller

Microcircuit is designed for stabilization of collector electric motor rotation speed. IC's supply power can be obtained from alternating current line with voltage 110 V or 220 V, frequency of 50 Hz or 60 Hz through half-wave rectifier and ballast resistor.

Functions:

Microcircuit enables stabilization of electric motor speed, optimal triac firing (2nd and 3rd quadrants), repetitive trigger pulses when triac current is interrupted by motor collector, changing of triac current at work with induced load, soft start, power failure detection and general circuit reset.

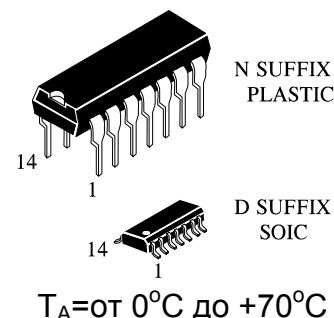

Features:

- Circuit power supply obtained from AC net
- Can be used in with AC networks 220 V / 50 Hz and 110 V / 60 Hz
- Low count and cost of external components
- Optimal triac firing (2nd and 3rd quadrants)
- Repetitive control pulses when current interrupted by electric motor collector
- Tracing triac current while operating for inductive load
- Possibility of Soft start mode setting
- Power error detection and general reset
- Embedded voltage comparator for expansion of circuit control functions
- Low bias input current at comparator's inputs: 100nA
- Low shift current at comparator's inputs $\pm 10\text{nA}$
- Damper of electrostatic discharge at comparator inputs increase circuit reliability
- Low power consumption

Symbols for pins in package

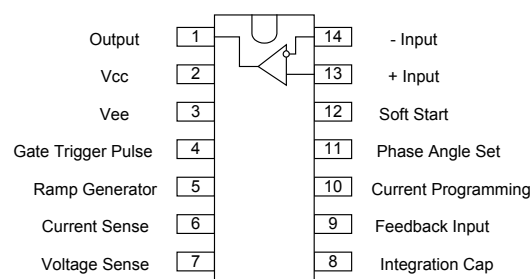

Stabilization of electric motor rotation speed is provided by integrated positive feedback on current. IL9010N generates triac control pulses and provides stabilization of collector motor speed without tacho generator.

Voltage comparator ensures control of basic circuit reset. While voltage levels coincidence, signal is generating at comparator inputs (inputs 13, 14) and shifts control circuit from «Permitted» state to the «Prohibited» state, in a similar way, as circuit state is changing while supply voltage low level. At that, circuit becomes insensitive to the supply voltage variation (circuit of supply voltage variation control is blocked by the signal from comparator output).



IL9010N

Maximum ratings.

Symbol	Parameter designation	Min	Max	Measuring unit
U_{pin}	Maximum voltage, On outputs 5,8,12- U_5, U_8, U_{12} On output 04- U_4	- U_{cc} -3.0	0 3.0	V
U_{pin11}	Maximum positive voltage at 11- U_{11} output	-	0	V
U_{pin3}	Maximum positive voltage at 03- U_3 output	-	0.5	V
I_{pin}	Maximum current At output 03- I_3 At outputs 06 and 07 - I_6, I_7 At output 09 - I_9	-20 -2,0 -0,5	+20 +2,0 +0,5	mA
I_{pin}	Maximum current, At output 10 - I_{10} At output 11 - I_{11}	+300 -500	-300 -	mcA
U_{IDR}	Input differential voltage range (outputs 13. 14)	- U_{cc}	0	V
I_{SC}	Output current of short circuit (output 01) relatively 02 output (U_{cc}) ¹	Constant		mA
P_D	Maximum dissipated power ($T_{amb}=25$ °C)	-	250	mWt
Tstg	Storage temperature range	-60	+125	°C
Rt j-a	Maximum temperature resistance «chip — environment»	-	100	°C/Wt

1 – Maximum output current (output 01) can obtain 20mA, not depending on power supply value. Shorted output circuits can cause over heat and, finally, destruction.

Tolerable ratings.

Symbol	Parameter designation	Min	Max	Measuring unit
T_A	Operation environment temperature range	0	+70	°C
Rt j-a	Maximum temperature resistance «chip — environment»	-	100	°C/Wt



IL9010N, IL9010D

Electrical characteristics: $T_A = 25\text{ }^\circ\text{C}$; (unless specified otherwise)

Symbol	Parameter designation	Measuring mode	Norm		Unit
			Min	Max	
1	2	3	4	5	6
-U _{cc}	Internal stabilizer voltage (output 03)	$I_3 = -2.0\text{ mA}$ $I_3 = -2.0\text{ mA}; 0^\circ\text{C} \leq T_A \leq 70^\circ\text{C}$	$ -7.6 $ $ -6.08 $	$ -9.6 $ $ -11.52 $	V
-I _{cc}	Consumption current	$U_3 = -6.0\text{ V}; I_4 = 0\text{ A}$ $U_3 = -6.0\text{ V}; I_4 = 0\text{ A}; 0^\circ\text{C} \leq T_A \leq 70^\circ\text{C}$	-	$ -2.5 $ $ -3.0 $	mA
U _{3EN}	Control enable voltage	-	$ -U_{cc} + 0.2 $ $ -U_{cc} + 0.18 $	$ -U_{cc} + 0.5 $ $ -U_{cc} + 0.55 $	V
U _{3DIS}	Control disable voltage, V	-	$ -U_{3EN} + 0.12 $ $ -U_{3EN} + 0.11 $	$ -U_{3EN} + 0.5 $ $ -U_{3EN} + 0.55 $	V
I ₁₁	Input current of output offset 11	-	-	-200 -240	nA
U ₈₋₁₁	Static bias of control voltage	-	1.2 0.96	2.0 2.4	V
I ₁₂	Soft start capacitor charging current	$R_{10} = 100\text{ k}\Omega$; $-U_{cc} \leq U_{12} \leq -3\text{ V}$ $R_{10} = 100\text{ k}\Omega$; $-U_{cc} \leq U_{12} \leq -3\text{ V}; 0^\circ\text{C} < T_A < 70^\circ\text{C}$	-11 -8.8	-17 -20.4	mA
I _{5P}	Sawtooth generator capacitor discharge current	$R_{10} = 100\text{ k}\Omega$; $0T - 2\text{ V} \leq U_5 \leq -6\text{ V}$ $R_{10} = 100\text{ k}\Omega$; $-2\text{ V} \leq U_5 \leq -6\text{ V}; 0^\circ\text{C} < T_A < 70^\circ\text{C}$	60 53	80 88	mA
I ₅₃	Sawtooth generator capacitor charging current	-	-1.5 -1.2	-10 -12	mA
U ₅	Sawtooth high voltage	-	$ -1.0 $ $ -0.8 $	$ -2.5 $ $ -3.0 $	V
U ₁₀	Programming output voltage relative to output 1	-	1.0 0.8	1.5 1.8	V
I ₄	Output current (incoming), mA	$U_4 = 0\text{ V}$ $U_4 = 0\text{ V}; 0^\circ\text{C} \leq T_A \leq 70^\circ\text{C}$	60 48	80 96	mA
I _{4L}	Output leakage current	$U_4 = 2.0\text{ V}$ $U_4 = 2.0\text{ V}; 0^\circ\text{C} \leq T_A \leq 70^\circ\text{C}$	-	4.0 4.8	mA
I _{sync}	Threshold level of current synchronization I ₆ , I ₇	-	-40 -48	40 48	mA
U _{LTH}	Minimum low sawtooth voltage (output 05)	-	$ -5.6 $ $ -5.0 $	$ -8.5 $ $ -9.35 $	V
I ₉	Input current of output offset of 09 output	$U_9 = 0\text{ V}$ $U_9 = 0\text{ V}; 0^\circ\text{C} \leq T_A \leq 70^\circ\text{C}$	$1.6 \times I_{5P}$ $1.4 \times I_{5P}$	$2.4 \times I_{5P}$ $2.6 \times I_{5P}$	-
A	Transfer function amplification coefficient, $\Delta U_8 / \Delta U_9$	$R_{10} = 100\text{ k}\Omega$; $\Delta U_9 = 50\text{ mV}$ $R_{10} = 100\text{ k}\Omega$; $\Delta U_9 = 50\text{ mV}; 0^\circ\text{C} \leq T_A \leq 70^\circ\text{C}$ $R_{10} = 270\text{ k}\Omega$; $\Delta U_9 = 50\text{ mV}$ $R_{10} = 270\text{ k}\Omega$; $\Delta U_9 = 50\text{ mV}; 0^\circ\text{C} \leq T_A \leq 70^\circ\text{C}$	50 45 28.8 25.9	90 99 50 55	-
U _{off}	Residual bias on 05-08 outputs	$U_9 = 0\text{ V}$ $U_9 = 0\text{ V}; 0^\circ\text{C} \leq T_A \leq 70^\circ\text{C}$	50 0	450 500	mV
Z ₈	Full internal resistance of 08 output	$U_9 = 0.1\text{ V}$ $U_9 = 0.1\text{ V}; 0^\circ\text{C} \leq T_A \leq 70^\circ\text{C}$	96 76.8	180 215	kOh m
tp	Output pulses duration	$C_5 = 47\text{ nF}; R_{10} = 270\text{ k}\Omega$	30	80	mcs



Korzhenenskogo 12, Minsk, 220108, Republic of Belarus
 Fax: +375 (17) 278 28 22,
 Phone: +375 (17) 278 07 11, 212 24 70, 212 24 61,
 212 69 16
 E-mail: office@bms.by
 URL: www.bms.by

BELMICROSYSTEMS

IL9010N

Symbol	Parameter designation	Measuring mode	Norm		Unit
			4	5	
1	2	3	4	5	6
		$C_5=47\text{ nF}; R_{10}=270\text{ kOhm}$ $0^\circ\text{C} \leq T_A \leq 70^\circ\text{C}$	24	96	
t	Repetition period of output pulses	$C_5=47\text{ nF}; R_{10}=270\text{ kOhm}$ $0^\circ\text{C} \leq T_A \leq 70^\circ\text{C}$	120	510	mks
U_{i0}	Input voltage of zero bias (outputs 13,14)	$R_{10}=100\text{ kOhm}$; Note 2 $0^\circ\text{C} \leq T_A \leq 70^\circ\text{C}$	–	$\pm 5,0$	mV
I_{iB}	Input offset current (outputs 13, 14)	$R_{10}=100\text{ kOhm}$; Note 2, 3 $0^\circ\text{C} \leq T_A \leq 70^\circ\text{C}$	–	-250 -400	nA
I_{i0}	Input currents difference (outputs 13, 14)	$R_{10}=100\text{ kOhm}$; Note 2 $0^\circ\text{C} \leq T_A \leq 70^\circ\text{C}$	–	± 50 ± 150	nA
U_{OL}	Output saturation voltage (output 01)	$R_{10}=100\text{ kOhm}$; $I_{01}=-4\text{ mA}$; $U_{14}=-U_{cc}+1,0\text{ V}$; $U_{13}=-U_{cc}$ $0^\circ\text{C} \leq T_A \leq 70^\circ\text{C}$	–	$-U_{cc}+0,4$ $-U_{cc}+0,7$	mV
I_{OL}	Output leakage current (output 01)	$R_{10}=100\text{ kOhm}$; $U_{13}=-U_{cc}+1,5\text{ V}$; $U_{14}=-U_{cc}$ $0^\circ\text{C} \leq T_A \leq 70^\circ\text{C}$	–	-1,0	mcA

Notes

1. Norm for electrical parameters are given for following conditions: environment temperature — $+25^\circ\text{C}$; voltage is related to output 02 «General», unless other specified.
2. Bias current on comparator's inputs of voltage comparator (outputs 13, 14), I_{iB} , nA, is outcoming (input cascades on outputs 13, 14 are performed on p-n-p transistors). This current is practically independent from supply voltage.
3. Measurements are implementing in switching point of voltage comparator (output 01); $U_{01}=-U_{cc}+1.5\text{V}$, $R_{13}, R_{14} \leq 100\text{ Ohm}$, over all range of input voltage of in-phase signal U_{iCRmax} от $-U_{cc}$ до 1.5 V (outputs 13, 14).
4. U_H, U_L parameters determine working capacity of internal control line of supply voltage tracing Positional resistor designations, given in the table, related to corresponding circuit outputs (for example, R10 on output– 10), but not to standard switching circuit.



IL9010N, IL9010D

Standard circuit of IC switching on.

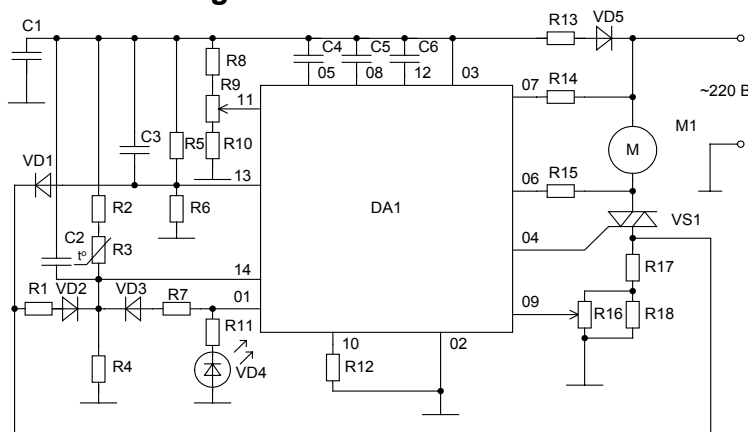

Figure 1 – Standard circuit of switching on IL9010N IC in circuit of commutator electric motor control and protection of motor from load current exceeding

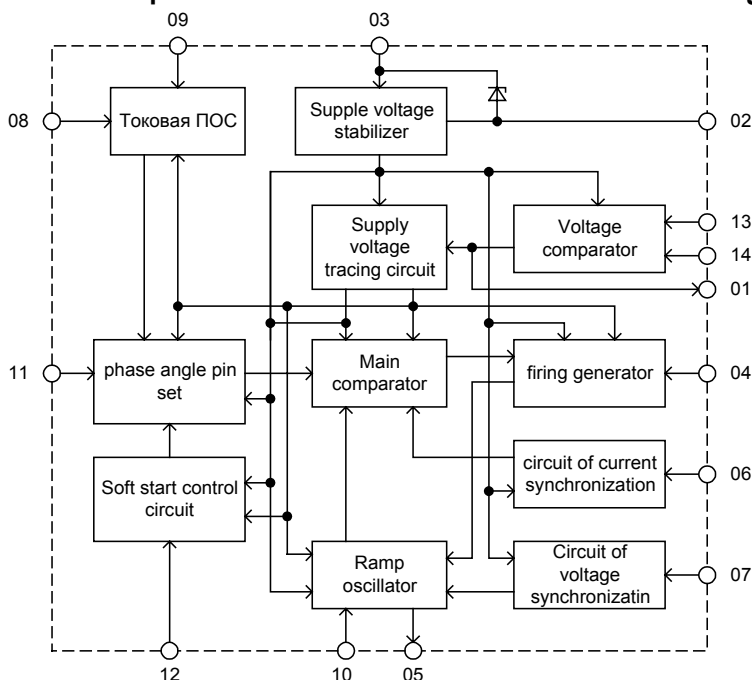

Figure 2 – Schematics of IL9010N IC

Functional description.

At fig. 1 is standard connection circuit of IL9010N IC in collector electric motor control circuit and motor protection from load current exceeding. In addition, circuit provides protection from motor overheat (resistor R3).

Motor protection from load current exceeding is implementing through protection circuit, performed on elements R1, R2, R4 - R7, R17, VD1 – VD3, outputs 13 (direct input of voltage comparator), 14 (inverting input of voltage comparator), 01 (voltage comparator output) of



IL9010N

IL9010N IC. When current flows through load (commutator electric motor) voltage on R17 resistor drops, and, in case when load current exceeds particular value, voltage drop on R17 resistor exceeds threshold value for actuation of protective circuit against load current exceeding.

Protective circuit provides function of load protection by the way of basis circuit disconnection (commutator electric motor circuit), and as a result switching pulses do not come from IC output (pin 04) to triac controlling electrode and triac load is not connected to AC line.

Protective circuit provides control of load current value in both half-periods of AC supply line voltage, electric motor and IL9010N IC obtain power supply. VD1 line, output 13 provides protection by load current exceeding in positive half-period of supply line voltage: due to increasing of potential differences on VD1 diode up to diode opening voltage, occurs current derivation from resistor voltage divider R5, R6 at supporting comparator shoulder (output 13), that results in reference voltage drop at given output, less than voltage on second comparator shoulder (output 14) and comparator switching.

Voltage comparator blocks supply voltage tracing circuit (transfer it to the "DISABLED" state) and disconnects the IC.

R1, VD2 line, output 14 provides protection by load voltage exceeding in negative half-period of net voltage: due to potential rising on R1 resistor and VD1 diode up to diode VD1 discover, occurs current derivation to resistance divider R2, R3, R4 at signal comparator shoulder (output 14), that causes increasing of output 14 potential and, by definite value of derived current, occurs comparator switching and IC disconnection.

R7, VD3 line provide hysteresis between voltage comparator connection and disconnection level. IC power supply is implementing directly from AC line through half-wave rectifier and ballast resistor (fig. 1). Rated zero-power resistance of ballast resistor is defining depending on providing of necessary mode of operation of half-wave rectifier, consisting of R5, VD1 elements and inner voltage regulator, based on backswitched supporting diod.

Voltage is held by inner stabiliton at the rate of -8.6 V related to general output (output 14).

Pin function description

Output number	Designation	Outputs function
01	Output	Comparator output
02	UCC	"General" bus connection output
03	U _{EE}	Negative voltage of circuit supply
04	Gate Trigger Pulse	output of disabling pulses generator
05	Ramp Generator	Connection of the capacitor, determines operational mode of voltage ramp generator
06	Current Sense	Current reading output
07	Voltage Sense	IC inner synchronization pin
08	Integration Capacitor	feedback output
09	Feedbak Input	feedback input
10	Current Programming	output of resistor connection, regulates bias current
11	Phase Angle Set	Phase Angle Set pin
12	Soft-Start	"soft-start "set output
13	+Input	comparator direct input
14	-Input	comparator inverse input

