

**HIGH-VOLTAGE LED DRIVER  
WITH BUILT-IN MOSFET SWITCH**

**IL9921/22/23**

**FEATURES**

- Operating temperature range -40 ..+85 °C
- ON-resistance of the MOSFET switch  
210 Ohm for ambient temperature 25 °C
- OFF-state breakdown voltage of the MOSFET switch not less 500 V for Ambient temperature 25 °C.

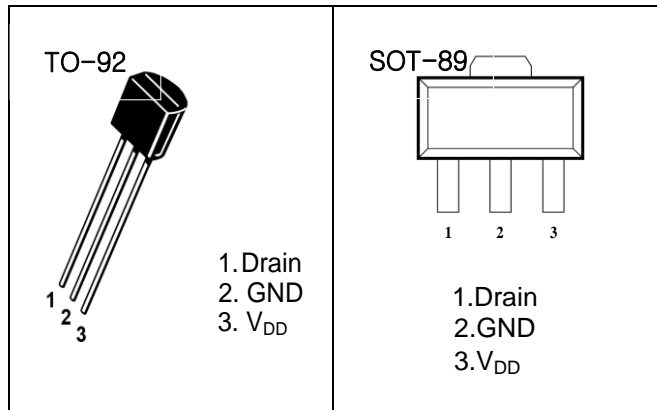

**ORDERING INFORMATION**

Device	Operating Temperature Range	Package	Packing
IL9921LF, IL9922LF, IL9923LF	T <sub>A</sub> = - 40 ... + 85 °C	TO-92	Tape
IL9921PT, IL9922PT, IL9923PT		SOT-89	Tape & Reel

**DESCRIPTION**

IL9921, IL9922, IL9923 are high-voltage LED driver control ICs with build-in MOSFET switch and purposed for LED lighting control.

They allow efficient operation of LED strings from voltage sources ranging up to 400VDC. The IL9921/22 includes an internal high-voltage switching MOSFET controlled with fixed off-time TOFF of approximately 10µs. The LED string is driven at constant current, thus providing constant light output and enhanced reliability. The output current is internally fixed at 20mA for IL9921, 50mA for IL9922 and 30mA for IL9923. The peak current control scheme provides good regulation of the output current throughout the universal AC line voltage range of 85 to 264V AC or DC input voltage of 20 to 400V.

**PIN DESCRIPTION**

Pin No	Symbol	Description
1	Drain	This is a drain terminal of the output switching MOSFET and a linear Regulator input.
2	GND	This is a common connection for all circuits
3	V <sub>DD</sub>	This is a power supply pin for all control circuits. Bypass this pin with a 0.1uF low impedance capacitor.

BLOCK DIAGRAM

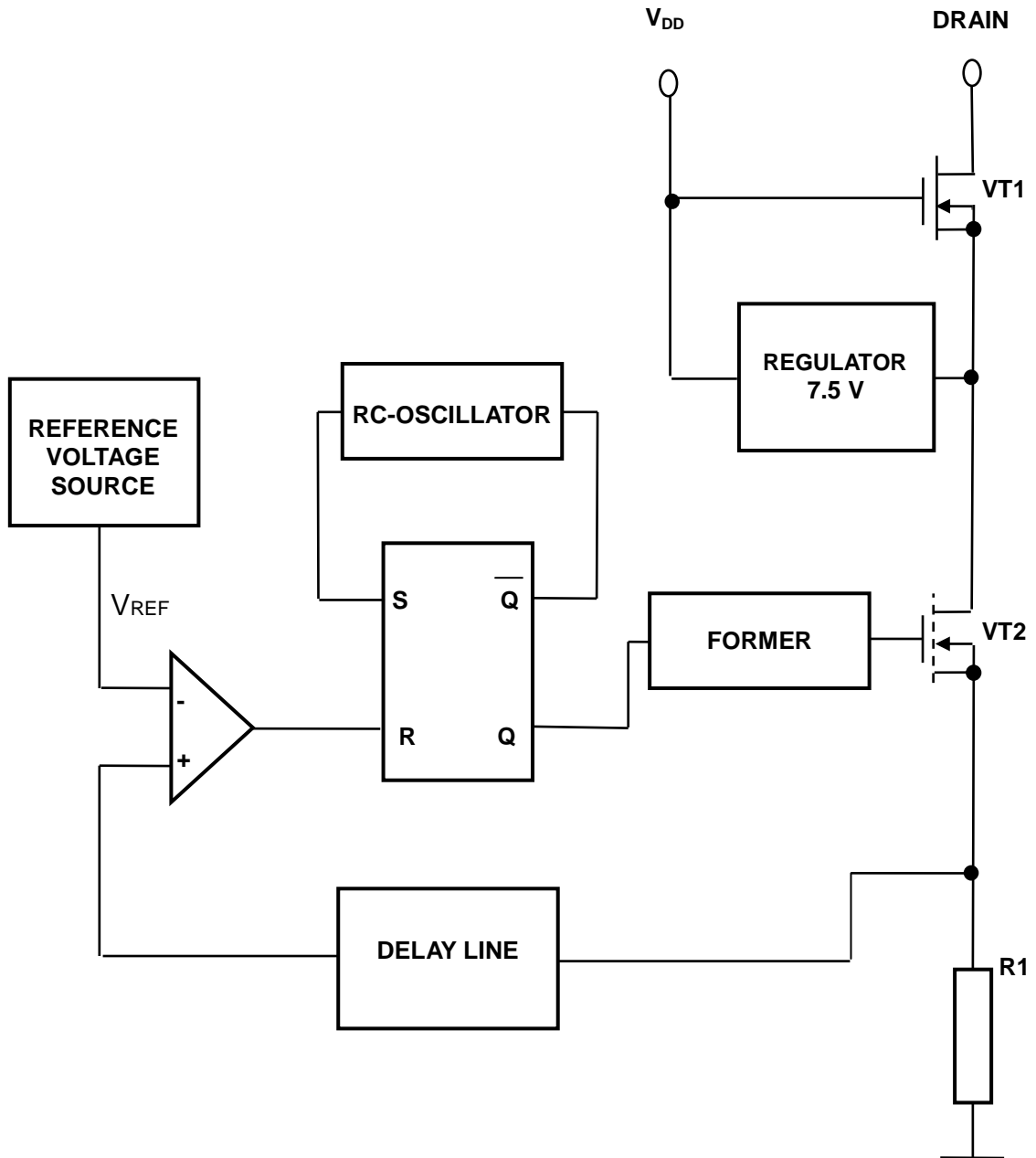

**ABSOLUTE MAXIMUM RATINGS**

Symbol	Parameter	Limit		Unit
		Min	Max	
V <sub>IN</sub>	Input voltage	-0.3	420	V
V <sub>DD</sub>	Low-voltage (control) part of IC supply voltage	-0.3	10	V

\* Stresses beyond those listed under “absolute maximum ratings” may cause permanent damage to the device. These are stress ratings only and functional operation of the device at these or any other conditions beyond those indicated under “recommended operating conditions” is not implied. Exposure to absolute-maximum-rated conditions for extended periods may affect device reliability.

**RECOMMENDED OPERATION RANGE**

Symbol	Parameter	Limit		Unit
		Min	Max	
V <sub>IN</sub>	Input voltage	20	400	V

**ELECTRICAL CHARACTERISTICS**

Symbol	Parameter	Test Condition	Limit		Ambient temperature, °C	Unit
			Min	Max		
V <sub>DDR</sub>	Regulator output voltage	V <sub>IN</sub> = (20- 400)V	5.5	9.0	25 ± 10	V
I <sub>DD</sub>	Low-voltage (control) part of IC consumption current	V <sub>DD</sub> = 9,5 V V <sub>IN</sub> = 40 V	-	350		uA
R <sub>ON</sub>	ON-resistance of the switch (DRAIN pin)	V <sub>DD</sub> = V <sub>DDR</sub> I <sub>DRAIN</sub> = 20 mA	-	210		Ohm
V <sub>UVLO</sub>	Undervoltage threshold (Low-voltage part of IC)	V <sub>DD</sub> = V <sub>UVLO</sub> I <sub>DRAIN</sub> = 20 mA	4.0	V <sub>DDR</sub> - 0.3		V
I <sub>SAT</sub>	MOSFET saturation current (DRAIN pin)	V <sub>DD</sub> = V <sub>DDR</sub> V <sub>SAT</sub> = 50 V	100	-		mA
V <sub>BR</sub>	OFF-state breakdown voltage of the MOSFET switch (DRAIN pin)	V <sub>DD</sub> = V <sub>DDR</sub> I <sub>DRAIN</sub> = 1 mA	500	-		V
I <sub>TH</sub>	Threshold current IL9921 IL9922 IL9923	V <sub>DD</sub> = V <sub>DDR</sub> V <sub>IN</sub> = 50 V	20.5 52.0 30.8	25.5 63.0 38.2	25 ± 10 -40 85	mA
T <sub>OFF</sub>	OFF time (DRAIN pin)	V <sub>DD</sub> = V <sub>DDR</sub> V <sub>IN</sub> = 50 V	8.0	13.0	25 ± 10	us
T <sub>ON</sub>	Minimum ON-time of the switch (DRAIN pin)		-	650		ns
T <sub>BLANK</sub>	Leading Edge Blanking Delay		200	400		ns

RECOMMENDED APPLICATION DIAGRAM

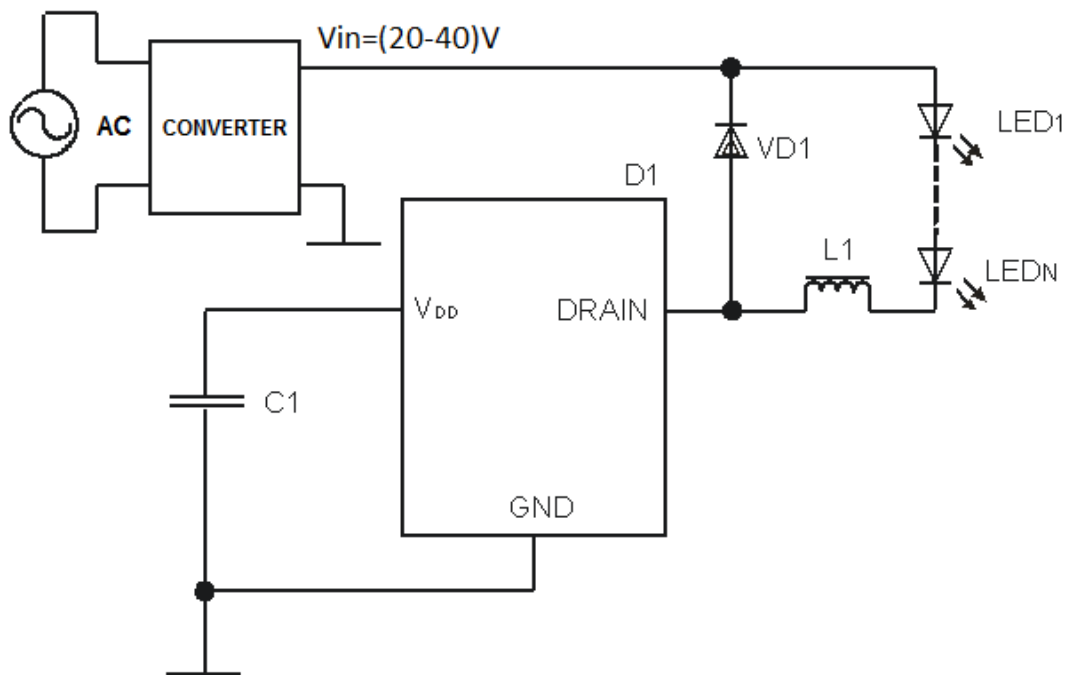

- AC – AC supply voltage source
- C1 – capacitor  $C = 0.1 \mu\text{F} \pm 10\%$
- D1 – microcircuit
- L1 – inductor (coil)

Inductor feature L, mH, is calculated by formula:

$$L = \frac{15 \cdot N \cdot U_F}{dI_o}$$

- N – Quantity of diodes in LED string, pcs.;
- $V_F$  – LED forward voltage for nominal current, V;
- $dI_o$  – LED circuit permissible current ripple, mA

LED<sub>1</sub> – LED<sub>N</sub> – LEDs (light emitting diodes) with nominal current:

- 20 mA for IL9921 application;
- 50 mA for IL9922 application;
- 30 mA for IL9923 application

VD1 – high-voltage diode with breakdown voltage not less 500V and forward current:

- not less 25.5 mA for IL9921 application;
- not less 63.0 mA for IL9922 application;
- not less 38.2 mA for IL9923 application

PACKAGE DIMENSION

TO-92

Taping Specification

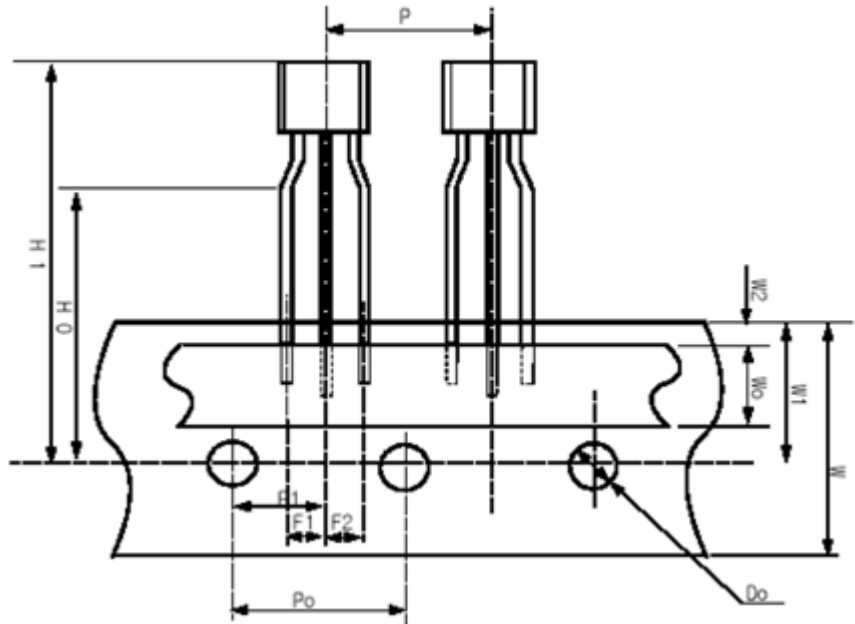
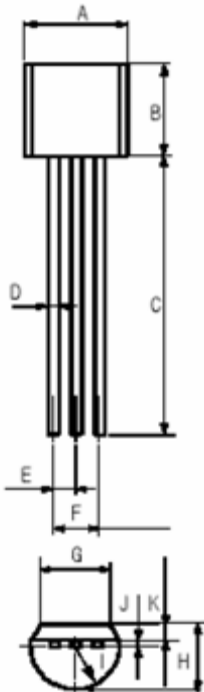

Package Dimension(unit:mm)				Taping Dimension(unit:mm)			
Symbol	Min	Typ	Max	Symbol	Min	Typ	Max
A	4.43	4.58	4.83	P	12.2	12.7	13.2
B	4.38	4.58	4.78	PO	12.5	12.7	12.9
C	14.07	14.47	14.87	P1	5.85	6.35	6.85
D	0.36	0.46	0.56	F1,F2	2.4	2.5	2.9
E	1.07	1.27	1.47	W	17.5	18.0	19.0
F	2.34	2.54	2.74	WO	5.5	6.0	6.5
G	3.40	3.60	3.80	W1	8.5	9.0	9.5
H	-	-	3.86	W2	-	-	1.0
I	-	[R2.29]	-	HO	15.5	16.0	16.5
J	0.33	0.38	0.39	H1	-	-	27.0
K	0.92	1.02	1.12	DO	3.8	4.0	4.2

SOT-89-3L

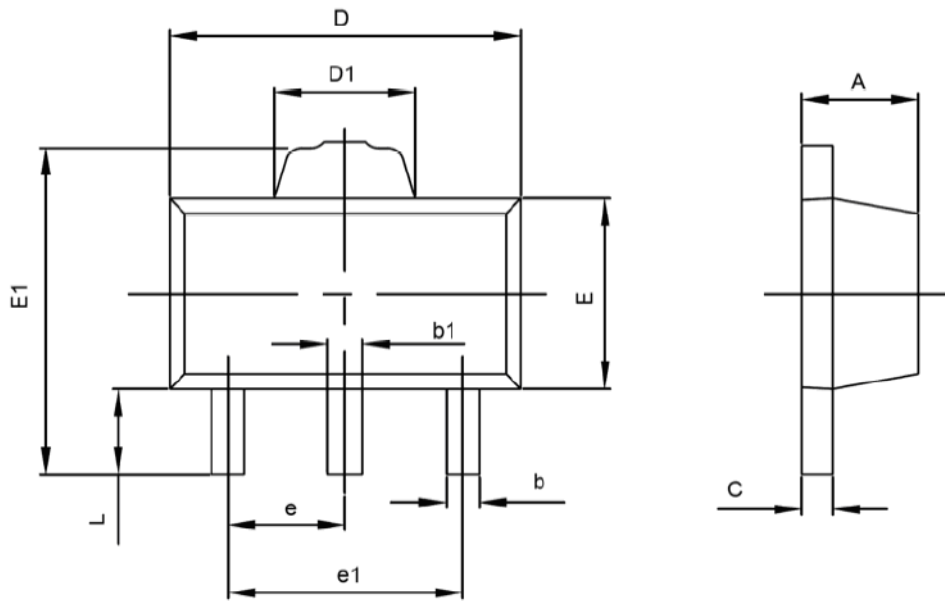

Symbol	Dimensions in Millimeters		Dimensions in Inches	
	Min	Max	Min	Max
A	1.400	1.600	0.055	0.063
b	0.320	0.520	0.013	0.020
b1	0.360	0.560	0.014	0.022
c	0.350	0.440	0.014	0.017
D	4.400	4.600	0.173	0.181
D1	1.400	1.800	0.055	0.071
E	2.300	2.600	0.091	0.102
E1	3.940	4.250	0.155	0.167
e	1.500TYP		0.060TYP	
e1	2.900	3.100	0.114	0.122
L	0.900	1.100	0.035	0.043